

# SERVICE MANUAL MANUEL DE SERVICE

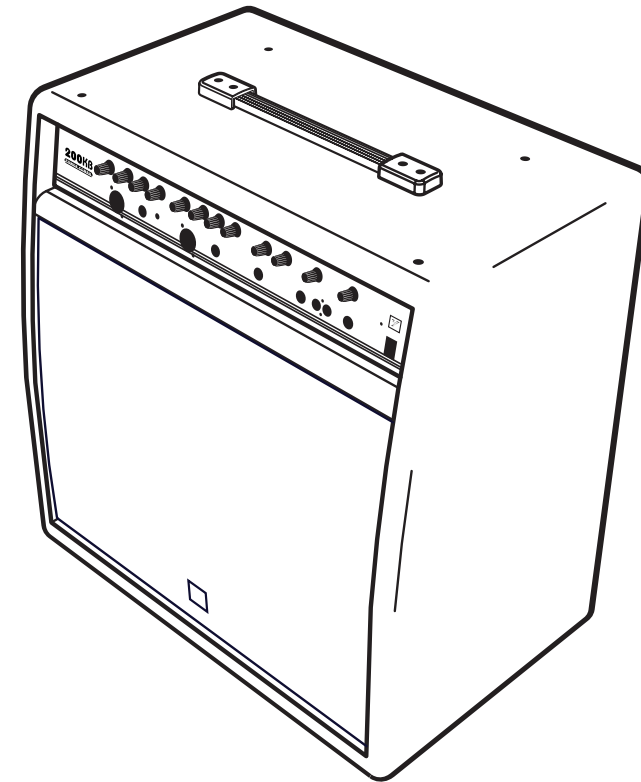

# 200KB

**POWER COMBO**



WEB ACCESS: <http://www.yorkville.com>

## WORLD HEADQUARTERS CANADA

**Yorkville Sound**  
550 Granite Court  
Pickering, Ontario  
L1W-3Y8 CANADA

Voice: (905) 837-8481  
Fax: (905) 837-8746

## U.S.A.

**Yorkville Sound Inc.**  
4625 Witmer Industrial Estate  
Niagara Falls, New York  
14305 USA

Voice: (716) 297-2920  
Fax: (716) 297-3689



Quality and Innovation Since 1963

Printed in Canada





200KBCE AC WIRING  
MAR 21, 2000

SHOWN WIRED FOR 245VAC

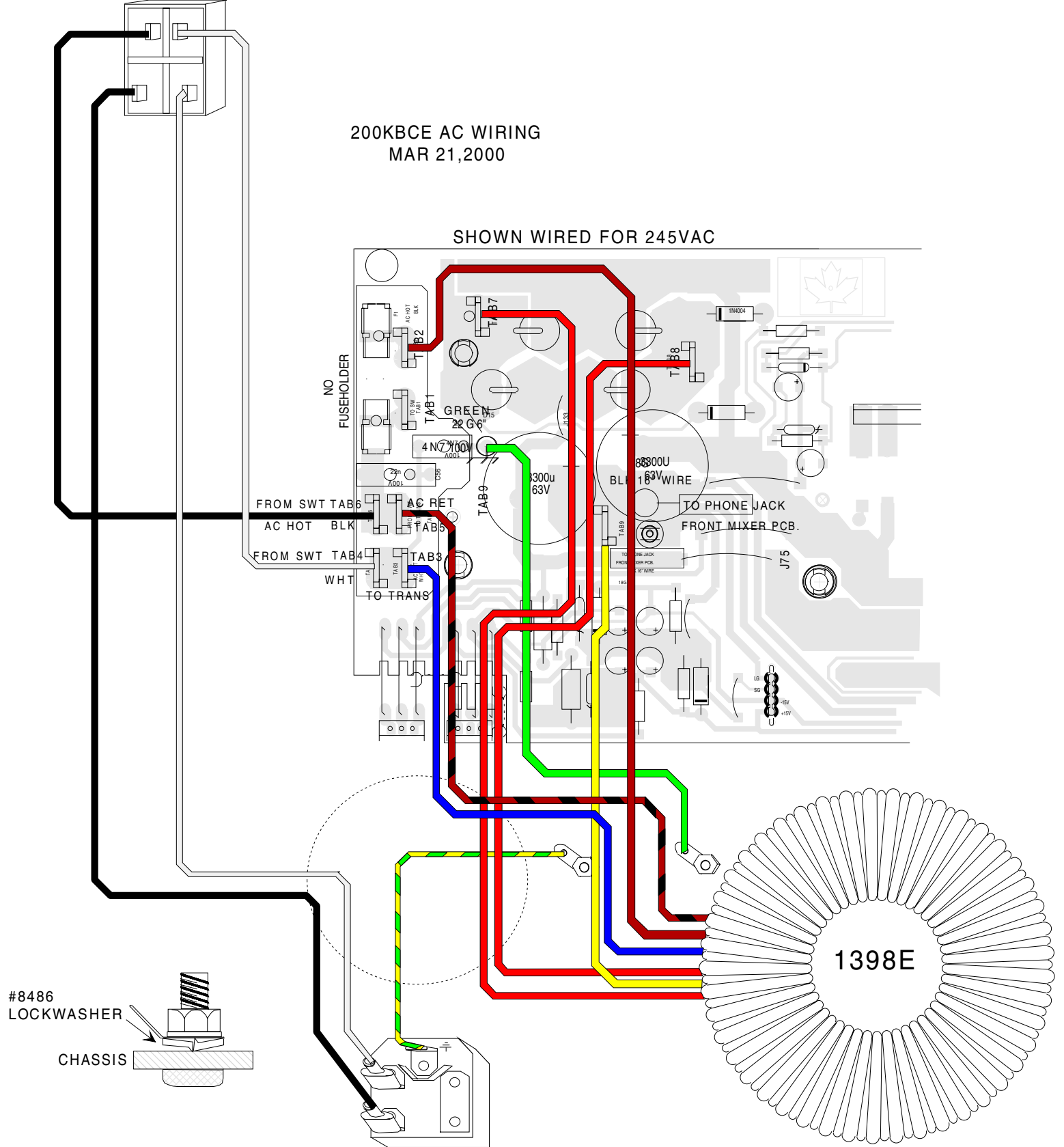





200KBV1.3.PRN

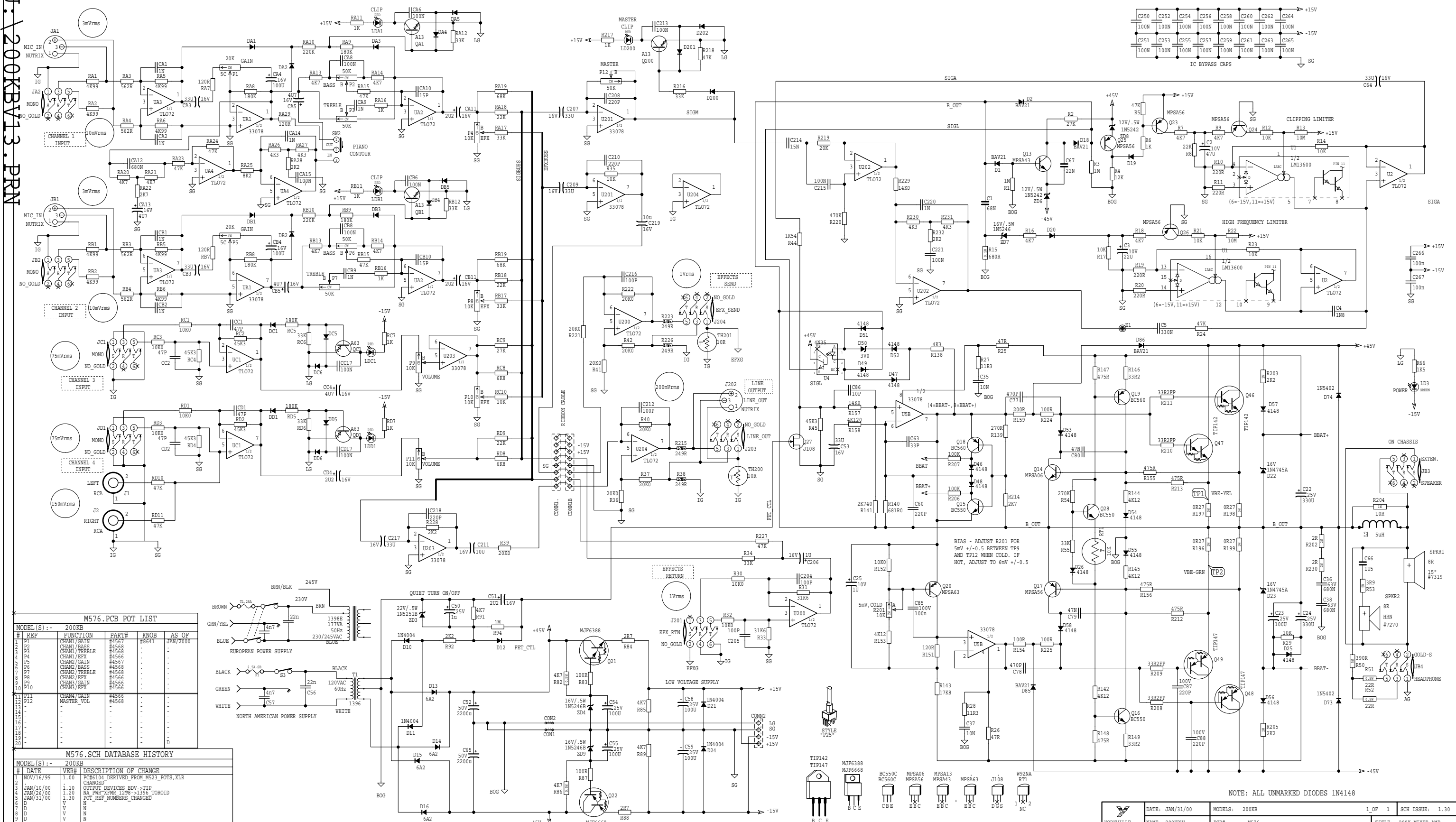

**M576.PCB POT LIST**

MODEL(S) :-	200KB				
#	REF	FUNCTION	PART#	KNOB	AS OF
P1	P1	CHANN1/GAIN	#4567	#8641	JAN/2000
P2	P2	CHANN1/BASS	#4568		
P3	P3	CHANN1/TREBLE	#4569		
P4	P4	CHANN1/EPX	#4570		
P5	P5	CHANN2/GAIN	#4571		
P6	P6	CHANN2/BASS	#4572		
P7	P7	CHANN2/TREBLE	#4573		
P8	P8	CHANN2/EPX	#4574		
P9	P9	CHANN3/GAIN	#4575		
P10	P10	CHANN3/BASS	#4576		
P11	P11	CHANN3/TREBLE	#4577		
P12	P12	CHANN3/EPX	#4578		
P13	P13	CHANN4/GAIN	#4579		
P14	P14	CHANN4/BASS	#4580		
P15	P15	CHANN4/TREBLE	#4581		
P16	P16	CHANN4/EPX	#4582		
P17	P17	MASTER_VOL	#4583		
P18	P18				
P19	P19				
P20	P20				

**M576.SCH DATABASE HISTORY**

MODEL(S) :-	200KB		
#	DATE	VER#	DESCRIPTION OF CHANGE
1	NOV/16/99	1.00	PCB LAYOUT DERIVED FROM M573_POTS_XLR CHANGED
2	JAN/10/00	1.10	OUTPUT DEVICES BOV - TIP
3	JAN/24/00	1.20	NEW PWR-FEEDER T288 - 1396 TOROID
4	JAN/31/00	1.30	POT_REF_NUMBERS_CHANGED
5			
6			
7			
8			
9			
10			



YS #	Description	Qty.	YS #	Description	Qty.	YS #	Description	Qty.
5906	RED 3MM LED 1V9 20MA .4SPCR T&R	5	3795	#8 GROUND LUG ZIERICK 505-169	2	8861	4-40 X 3/8 PAN PH MS JS500	2
5908	GRN 3MM LED 1V9 20MA .4SPCR T&R	1	3810	4" NYLON CABLE TIE	11	8842	#4 X 5/16 PAN QUAD TYPE A JS500 BLK	6
6425	BAV21 200V 0A25 DIODE T&R	5	8636	BUTTON KNOB FLAT BLACK	2	8801	6-32 X 3/8 PAN PH TAPTITE JS500	3
6825	1N4148 75V 0A45 DIODE T&R	36	8641	AQUA KNOB FOR "NEW" ACOUSTIC SERIE	12	8828	6-32 X 3/4 PAN PH TAPTITE JS500	7
6438	1N4004 400V 1A0 DIODE T&R	4	3481	8' 3/18 SJT AC LINE CORD 250 CLIPS	1	8815	8-32 X 3/4 PAN PH TAPTITE JS500	2
6827	1N5402 200V 3A0 DIODE	2	3834	HEYCO #1214 STRAIN RELIEF	1	8749	10-32 X 1/2 QDX PH TAPTITE JS500	1
6434	6A2 200V 6A0 DIODE	4	8261	GE VELVET LEXAN .007" X 12" X 24"	0.5	8736	5/16-18X2-3/4 GRD 5 HEX BOLT JS500	1
6439	1N5225B 3V0 0W5 ZENER 5% T&R	1	3543	20 PIN BRKAWAY 90 LOCK .156	0.2	8607	3/16 NYLON SPACER OD 1/8 X ID .063	8
6450	1N5242B 12V0 0W5 ZENER 5% T&R	2	3548	SIDE ENTRY PCB CONN .156 4POS	1	3744	SNAP IN .375 SPACER RICHCO	7
6822	1N4745A 16V0 1W0 ZENER 5% T&R	2	3676	8 CIR CABLE HOLDER .098	2	3859	1/2 PLASTIC HEX SPACER #4	5
6824	1N5246B 16V0 0W5 ZENER 5% T&R	3	5989	4 CIR CABLE HOLDER .098	2	8818	3/4 OD X 5/16 ID X .08 THICK WASHER	2
6463	1N5251BRL 22V0 0W5 ZENER 5% T&R	1	8800	6-32 KEPS NUT ZINC	3	8473	#10 BLACK CUPWASHER SWF-10BK	1
5101	BC550C TO92 NPN TRAN T&R TB	3	8898	1/4-20 CAGE NUT C7998142027	4	3425	DPDT PUSH SW PCMT MAKE B4 BREAK	1
5102	BC560C TO92 PNP TRAN T&R TB	2	8797	5/16-18 KEPS NUT JS500	1	3698	SPST ROKR SW QUIK 180" AC PWR BL/BL	1
5103	MPSA06 TO92 NPN TRAN T&R TA	1	3830	TO218 PREGREASED MICA 56-78-2AP	4	8468	VELCRO STRAP 3/4"X22CM (VELSTRAP)	1
5104	MPSA56 TO92 PNP TRAN T&R TA	5	8581	CUSTOM PBL TRANSISTOR SPACER	2	1396	125VAC DOUBLE INSULATION T'RD	1
5109	MPSA43 TO92 NPN TRAN TA	1	4597	22AWG STRAN TC WIR JMP	50			
5105	MPSA13 TO92 NPN DARL T&R TA	3	4599	22AWG SOLID SC WIR T&R JMP	86			
5106	MPSA63 TO92 PNP DARL T&R TA	4	5299	24AWG SOLID SC WIR RAD JMP	2			
5122	J109 TO92 NCH JFET T&R TC	1	4729	5.0W 0R27 5% BLK RES	4			
6814	MJF6668 T221D PNP TRAN DARL TJ	1	4703	2.0W 2R 5% T&R RES	2			
6815	MJF6388 T221D NPN TRAN DARL TJ	1	4905	1/4W 2R7 5% T&R RES	2			
6902	TIP142 TO218 NPN TRAN DARL TE	2	4734	5.0W 3R9 5% BLK RES	1			
6903	TIP147 TO218 PNP TRAN DARL TE	2	4686	1.0W 10R 5%FLAME PROOF T&R RES	1			
6754	NJM072BL IC DUAL OPAMP INLINE	1	4766	1/4W 11R3 1%FLAME PROOF T&R RES	2			
6840	MC33078P IC DUAL OP AMP	4	4618	1/2W 22R 5% T&R RES	2			
6882	TL072CP IC FET DUAL OP AMP	7	4995	1/4W 33R2 1%FLAME PROOF T&R RES	6			
6745	LM13600N IC XCONDUCTANCE AMP	1	4957	1/4W 47R 5% .2"U T&R RES	2			
6880	4N35 OPTO-COUPLER	1	4852	1/4W 100R 5% T&R RES	5			
6467	10K 10% THERMISTOR NTC TO-92	1	4987	1/4W 120R 5%MINI T&R RES	4			
6474	10R 3% 0W0 PTC THERMISTOR	2	4909	1/4W 200R 5% T&R RES	1			
5400	10P 100V 10%CAP T&R BEAD NPO	1	4857	1/4W 220R 5% T&R RES	4			
5402	15P 100V 10%CAP T&R BEAD NPO	2	4606	1/8W 249R 2%FLAME PROOF T&R RES	4			
5406	33P 50V 10%CAP BLK BEAD NPO	1	4986	1/4W 270R 5%MINI T&R RES	1			
5408	47P 100V 10%CAP T&R BEAD NPO	4	4736	5.0W 390R 5% BLK RES	1			
5410	100P 100V 10%CAP T&R BEAD NPO	4	4698	1/8W 475R 1%FLAME PROOF T&R RES	6			
5197	220P 100V 2%CAP T&R RAD CER.2"NPO	2	4799	1/4W 562R 1% T&R RES	4			
5412	220P 100V 10%CAP T&R BEAD NPO	4	4673	1/2W 680R 5% T&R RES	1			
5416	470P 50V 10%CAP T&R BEAD NPO	2	4743	1/4W 681R0 0.1% *** T&R RES	1			
5422	1N 50V 10%CAP T&R BEAD NPO	8	4981	1/4W 1K 5%MINI T&R RES	8			
5425	1N8 50V 10%CAP T&R BEAD X7R	1	4988	1/4W 1K5 5%MINI T&R RES	1			
6451	4N7 250V 20%CAP BLK 'Y' 10MM AC	1	4791	1/4W 1K54 1% T&T RES	1			
5300	10N 50V 10%CAP T&R BEAD X7R	2	4705	2.0W 2K2 5% BLK RES	2			
5205	15N 100V 10%CAP T&R RAD .2"FLM	1	4847	1/4W 2K2 5% T&R RES	4			
5210	22N 100V 10%CAP T&R RAD .2"FLM	1	4864	1/4W 2K7 5% T&R RES	2			
6435	22N 275V 20%CAP BLK 'X2' 15MM AC	1	4764	1/4W 2K740 0.1% *** T&R RES	1			
5224	47N 100V 10%CAP T&R RAD .2"FLM	2	4756	1/4W 4K120 0.1% *** T&R RES	1			
5226	68N 100V 5%CAP T&R RAD .2"FLM	1	4774	1/4W 4K12 1% T&R RES	4			
5228	100N 100V 5%CAP T&R RAD .2"FLM	3	4910	1/4W 4K3 5% T&R RES	5			
5314	100N 50V 10%CAP T&R BEAD X7R	26	4627	1/2W 4K7 5% T&R RES	2			
5320	330N 50V 10%CAP T&R BEAD X7R	1	4982	1/4W 4K7 5%MINI T&R RES	13			
5240	680N 63V 10%CAP T&R RAD .2"FLM	3	4639	1/4W 4K99 1% T&R RES	8			
5255	1U 63V 20%CAP T&R RAD .2"EL	3	4978	1/4W 6K8 5%MINI T&R RES	2			
5925	1U5 100V 10%CAP BLK RAD POLY FLM	1	4863	1/4W 8K2 5% T&R RES	1			
5257	2U2 63V 20%CAP T&R RAD .2"EL	4	4800	1/4W 10K0 1% T&R RES	7			
5259	4U7 63V 20%CAP T&R RAD .2"EL	4	4829	1/4W 10K 5% T&R RES	8			
5281	10U 16V 20%CAP T&R RAD .2"NP	2	4856	1/4W 12K 5% T&R RES	1			
5260	22U 50V 20%CAP T&R RAD .2"EL	1	4775	1/4W 14K0 1% T&R RES	2			
5961	33U 16V 20%CAP T&R RAD .2"NP	7	4771	1/4W 17K8 1% T&R RES	1			
5627	47U 10V 20%CAP BLK RAD NP	1	4885	1/4W 20K 5% T&R RES	1			
5267	100U 25V 20%CAP T&R RAD .2"EL	7	6123	1/4W 20K0 1%MINI MF T&R RES	8			
5630	330U 25V 20%CAP BLK 10X13MM EL	2	6118	1/4W 22K 5%MINI T&R RES	4			
5617	3300U 63V 20%CAP BLK 25X31MM ELS	2	6129	1/4W 27K 5%MINI T&R RES	2			
4566	10K B LIN 9MM P25	5	4917	1/4W 31K6 1% T&R RES	2			
4567	20K 5C R/A 9MM P25	2	6122	1/4W 33K 5%MINI T&R RES	9			
4568	50K B LIN 9MM P25	5	4908	1/4W 45K3 1% T&R RES	5			
4520	10K TRIM POT	1	6119	1/4W 47K 5%MINI T&R RES	10			
3819	5UH COIL 18AWG R000 AIR CORE	1	4836	1/4W 68K 5% T&R RES	2			
3682	250 MALE PCB TAB BULK CARTRIGE	11	6120	1/4W 100K 5%MINI T&R RES	2			
3498	1/4" JCK PCB MT HORZ	7	4796	1/4W 180K 5%MINI T&R RES	6			
3527	1/4" JCK PCB MT HORZ GOLD S	1	4841	1/4W 220K 5% T&R RES	2			
3528	1/4" JCK PCB MT HORZ GOLD TR	1	6135	1/4W 270K 5%MINI T&R RES	1			
3460	RCA DUAL PCB MT VERT GOLD .475"	1	4843	1/4W 470K 5% T&R RES	1			
3660	XLR FEML PCB MT HORZ	2	4844	1/4W 1M 5% T&R RES	3			
3923	XLR MALE PCB MT HORZ MTHOLE-V SNAP	1	4809	1/4W 10M 5% T&R RES	2			
3451	EYELET SMALL 0.089 OD PLATED	21	3609	.6" 5C-26AWG RIBBON CABLE 0.1"	1			
3414	INTERNATIONAL PC MOUNT FUSEHOLDER	2	3594	.95" 5C-24AWG RIB.5NTCH HITMP 0.1"	1			
2407	2.5 AMP SLO-BLO .25X1.25 FUSE	1	3595	17" 8C-24AWG RIB.5NTCH HITMP 0.1"	1			
3501	B52200F006 COMP WASH #4 SMALL	2	9150	.081" 48X96 UTILITY ALUMINUM	4			
3719	DUAL XSISTOR TO218 SPRING YEL PLTD	2	8865	4-40 X 5/16 PAN PH MS JS500	10			
3804	SNAP ON 1.5" INSULATING BUSHING	1	8742	4-40 X 3/8 PAN PH TAPTITE JS500	2			