

Section F6: Power Supply Using Power Transistors

In this section of our studies we will be looking at the design of power supplies using power transistors. We discussed the concepts of rectification and filtering using regular and zener diodes in Section B, and we are going to start this section with a twist on our previous work – adding a BJT. After this introduction using discrete transistors, we will be examining design approaches using integrated circuits – both the 7800 series of integrated circuit regulators and the LM317 adjustable regulator.

Power Supply Using Discrete Components

In Section B9 (3.4 of your text), we used the zener diode as the voltage-controlling device in the design of a regulated power supply. The figure to the right is a modified version of Figure 8.20 in your text, where the notation has been changed to correctly reproduce Figure 3.39. As we saw earlier, this is a fairly well behaved circuit that supplies a nearly constant output voltage over a wide range of currents.

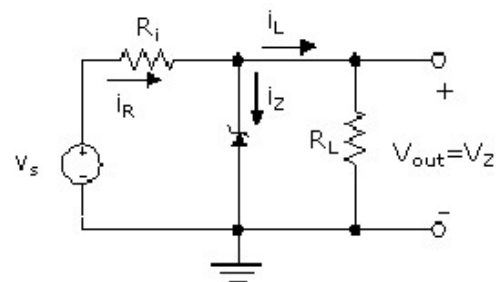

However, as we always must, we can do better. A better regulation may be obtained if the zener diode is connected to the base circuit of a power transistor in the EF (CC) configuration as shown below (Figure 8.21 of your text).

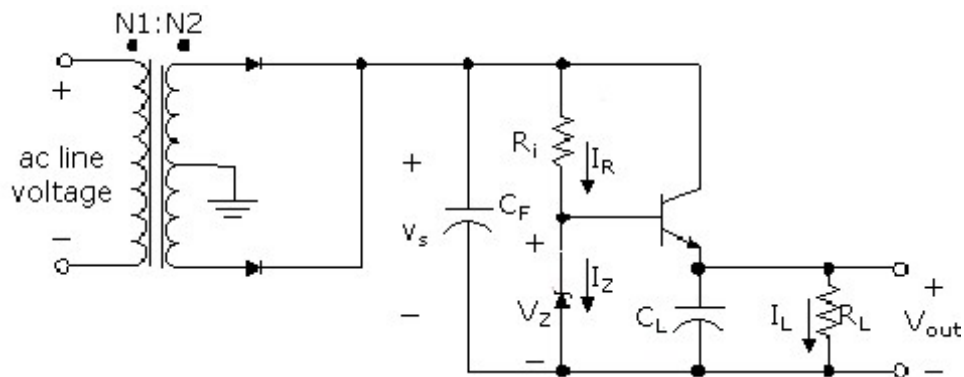

In the configuration above, the transistor is referred to as a **pass** transistor. Because of the current amplifying properties of the BJT in the EF (CC) configuration, the current through the zener diode may be small. With the smaller current, there is little voltage drop across the diode resistance, which allows the zener to approximate an ideal constant voltage source. The purpose of C_L in this circuit is to short out high frequency variations, so that

discrepancies in any of the regulated power supply loads will not be fed to any other loads.

If we assume the capacitor C_L is open to dc and $\beta \gg 1$, $I_L = I_E = \beta I_B$. Using KCL, the current through the resistor R_i is the sum of the zener diode current plus the transistor base current, or

$$I_R = I_Z + I_B = I_Z + I_L / \beta .$$

Directly analogous to our work in Section B9, we are going to define two extremes for I_Z in terms of the input/output conditions:

1. I_{zmin} occurs when the base current is maximum ($I_{Bmax} = I_{Lmax} / \beta$) and the source voltage is minimum.
2. I_{zmax} occurs when the base current is minimum ($I_{Bmin} = I_{Lmin} / \beta$) and the source voltage is maximum.

Circuit analysis techniques yield an expression for the resistor of interest as in Equation 3.56, where I_L is replaced with I_B . Equating the characteristics for the extremes of I_Z (defined as I_{zmin} and I_{zmax}) into the expression for R_i ($= (V_s - V_Z) / I_R$), we obtain

$$R_i = \frac{V_{smin} - V_Z}{I_{Lmax} / \beta + I_{zmin}} = \frac{V_{smax} - V_Z}{I_{Lmin} / \beta + I_{zmax}} . \quad (\text{Equation 8.48})$$

Once again using the rule of thumb approximation $I_{zmin} = 0.1 I_{zmax}$, and performing massive quantities of algebra, we can get the expression for I_{zmax} to be

$$I_{zmax} = \frac{I_{Lmin}(V_Z - V_{smin}) + I_{Lmax}(V_{smax} - V_Z)}{\beta(V_{smin} - 0.9V_Z - 0.1V_{smax})} , \quad (\text{Equation 8.50})$$

or, by rearranging our rule of thumb to $I_{zmax} = 10 I_{zmin}$, the expression for I_{zmin} is found to be

$$I_{zmin} = \frac{I_{Lmin}(V_Z - V_{smin}) + I_{Lmax}(V_{smax} - V_Z)}{\beta(10V_{smin} - 9V_Z - V_{smax})} .$$

Note that the above expressions for the current through the zener diode are the same as those in Section B9, except that the zener diode current has been reduced by the β of the transistor. The design of the power supply is performed exactly as previously with the exception of the reduced I_Z .

To estimate the capacitor C_F , we determine the equivalent load seen by this capacitor. Assuming the impedance of C_L is very large for dc (ideally open), it may be neglected in the parallel combination of $Z_{CL} || R_L$. This leaves us with the worst case situation of load resistance for the equivalent load, or

$$R_L(\text{equivalent}) = R_L(\text{worst case}) = \frac{V_{S\min}}{I_{L\max}}. \quad (\text{Equation 8.51})$$

The expression of Equation 8.51 was defined as the worst case since it represents the smallest load and, therefore, the largest load current. Substituting Equation 8.51 into Equation 3.62, we get an expression for C_F :

$$C_F = \frac{V_{s\max} - V_Z}{\Delta V f_p R_L(\text{equivalent})}. \quad (\text{Equation 8.52})$$

Since the voltage gain of an EF (CC) amplifier may be approximated as unity, the output voltage of the regulated power supply is

$$V_{out} = V_E = V_B - V_{BE} = V_Z - V_{BE}. \quad (\text{Equation 8.53, Modified})$$

If we assume that V_{BE} remains constant, the percent regulation of this power supply is given by

$$\%regulation = \frac{V_{Z\max} - V_{Z\min}}{V_Z} * 100 = \frac{R_Z(I_{Z\max} - I_{Z\min})}{V_Z} * 100, \quad (\text{Equation 8.55})$$

where V_Z is the nominal zener voltage. The percent regulation has been significantly reduced by using the BJT in the circuit since both $I_{Z\max}$ and $I_{Z\min}$ are divided by the β of the transistor.

Power Supply Using IC Regulator (Three-Terminal Regulator)

The IC regulator further improves the performance of the zener diode regulator by incorporating an operational amplifier. Using a single IC regulator and a few external components, excellent regulation may be obtained, along with good stability and reliability and built-in overload protection. In the following discussion, basic design considerations for IC regulators used in the design of power supplies for low power applications will be presented.

A functional block diagram of a generic IC regulator using **series regulation** is presented to the right and in Figure 8.22 of your text. The series regulator is based on the use of one or more pass transistors that possess a variable voltage that is in series with the output voltage. The voltage across the pass transistor(s) is varied by the output of the error amplifier so as to keep the output voltage constant. Specifically,

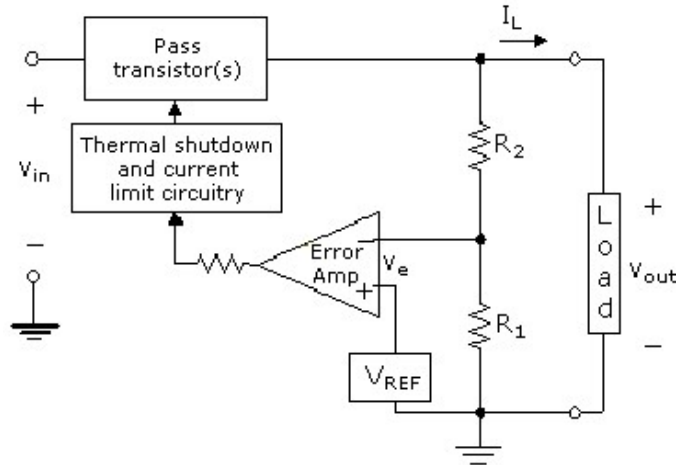

- A reference voltage, V_{REF} , is compared with the voltage divided output, v_{out} . The resulting error voltage, v_e is given by

$$v_e = V_{REF} - \frac{R_1 v_{out}}{R_1 + R_2}. \quad (\text{Equation 8.55})$$

- v_e is amplified through a discrete amplifier (shown as an operational amplifier in the figure), and is used to change the voltage drop across the pass transistor. This feedback system generates a variable voltage across the pass transistor to force the error voltage to zero.
- When the error voltage is zero, and since R_1 , R_2 and V_{REF} are constants, we obtain an expression for v_{out} that is independent of any variations in load current or input voltage from Equation 8.55:

$$V_{out} = \left(1 + \frac{R_2}{R_1}\right) V_{REF}. \quad (\text{Equation 8.56})$$

The thermal shutdown and current limit circuitry that exists between the error amplifier and the pass transistor(s) protects the regulator in case the temperature becomes too high or the current too large.

The maximum power dissipated in this type of series regulator is the power dissipated in the pass transistor, which is approximately equal to

$$P_{max} \approx (V_{inmax} - V_{out}) I_{Lmax}.$$

Therefore, as the load current increases, the power dissipated in the pass transistor increases. It is extremely important that the manufacturer's recommendations as to maximum current with and/or without a heat sink be

followed. Your text uses the example of an I_{Lmax} of 0.75A without a heat sink that may be increased to 1.5A when the IC package is correctly secured to a heat sink.

Power Supply Using 7800 Series IC Regulators

In the 7800 family of IC regulators, the last two digits indicate the output voltage of the device. There are a number of different voltages that may be obtained from the 7800 ICs. The specific IC designations, as well as the output voltage and maximum and minimum input voltages, are given to the right in a modified version of Table 8.1 of your text. The specification sheets for the 7800 series are given in the Appendix of your text (pages 949-954).

Type	V _{out}	V _{inmin}	V _{inmax}
7805	5	7	25
7806	6	8	25
7808	8	10.5	25
7885	8.5	10.5	25
7810	10	12.5	28
7812	12	14.5	30
7815	15	17.5	30
7818	18	21	33
7824	24	27	38

A typical circuit application of the 7800 IC family is shown in Figure 8.23b and is reproduced to the right. The terminal designations (shown in blue) are based on the three-terminal package of Figure 8.23a. In

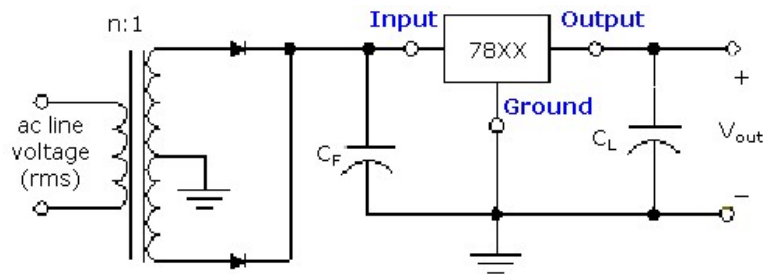

order to design a regulator using one of these ICs, and ensure that the required minimum and maximum input voltages are maintained, we need to select an appropriate transformer and filter capacitor.

The information of Table 8.1 is used to select the turns ratio ($n=N_1/N_2$, where N_1 is the number of turns on the primary side and N_2 is the number of turns on the secondary side). As a design guide, and as a conservative method for selecting the transformer turns ratio, it is common practice to proceed as follows:

- Take the average of V_{inmax} and V_{inmin} of the particular IC regulator to calculate AVG. Your text uses the example of the 7805 regulator, where $V_{inmax}=25V$ and $V_{inmin}=7V$, for $AVG=16$.
- Using the center tapped transformer provides a division by 2, so the peak voltage out of the rectifier is

$$AVG = (ac\ line\ voltage\ (rms)) * \sqrt{2} / (2n) .$$

Once again, for the example using the 7805, if the rms value of the ac line voltage is 115V, we get $115\sqrt{2} / 2n = 16$, or, $n=5$.

The filter capacitor is chosen to maintain the input voltage to the regulator as specified in Table 8.1 by calculating

$$C_F = \frac{V_{\max}}{\Delta V f_p R_L},$$

where

V_{\max} is the average of $V_{in\max}$ and $V_{in\min}$ from Table 8.1,

$\Delta V = V_{\max} - V_{in\min}$

$f_p = 120$ for a 60Hz input (full wave recitification), and

$R_L = V_{in\min} / I_{L\max}$ (or the worst case value).

According to the manufacturer's data sheet, the capacitor at the output (C_L) is not needed for stability; however, it does improve the transient response of the regulator. It is further noted that capacitance values of less than $0.1\mu\text{F}$ could cause instability. Your author states that C_L should be a high quality tantalum capacitor with a capacitance of $1.0\mu\text{F}$, and should be connected close to the 78XX regulator using short leads to improve the stability performance. Other possible applications for the 78XX regulator are illustrated on page 953 of your text.

Power Supply Using Three-Terminal Adjustable Regulator

The LM317 IC is an adjustable three-terminal positive regulator that is capable of supplying more than 1.5A over an output range of 1.2 to 37V. Figure 8.24, given to the right, shows a connection diagram for the LM317 with the terminal designations indicated in blue. Setting the output voltage requires only two external resistors, denoted R_1 and R_2 in the figure. As for the 7800 family, the capacitor C_L is optional. When it is included, the transient response is improved through the rejection of transients that may appear on the regulated supply line. Your author further states that the capacitor C_1 is needed if the device is physically located far from filter capacitors. However, an input bypass capacitor is usually used to short out any high frequency variations that may occur in adjoining circuitry.

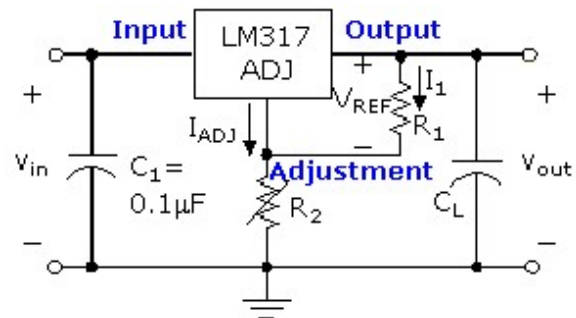

The voltage, V_{REF} , maintains a nominal 1.25V that is developed from a precision internal voltage reference. V_{REF} appears between the output and adjustment terminals and across the **program resistor**, R_1 . Since V_{REF} and R_1 are constants, there is a constant current through R_1 of $I_1 = V_{REF}/R_1$. The output voltage is then given by

$$V_{out} = V_{REF} + (I_1 + I_{ADJ})R_2 = V_{REF} \left(1 + \frac{R_2}{R_1} \right) + I_{ADJ}R_2. \quad (\text{Equation 8.58})$$

The LM317 is packaged in a standard transistor package and provides both current limiting and thermal overload protection. Your author states that both line and load regulations are better than in standard fixed voltage regulators.

Higher Current Regulator

The regulators that we've been talking about so far, in common with most IC regulators, are limited to an output current of about 1.5A due to the large amount of power dissipated in the internal pass transistor(s). The configuration presented in Figure 8.25, and reproduced to the right,

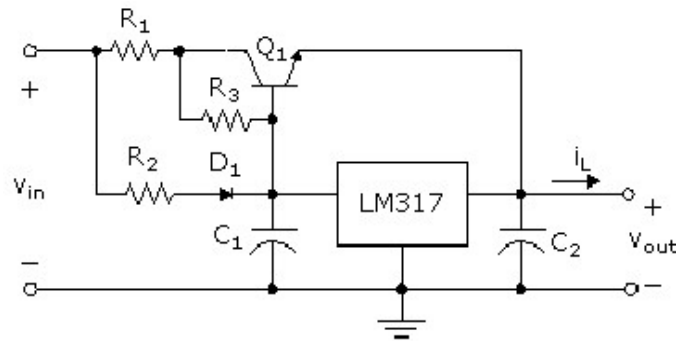

allows the output current to increase to about 5A while still preserving the thermal shutdown and short circuit protection of the IC.

The concept of this circuit is that the external power transistor Q_1 , which acts as a pass transistor for the regulator, provides 80% of the load current, while the regulator carries only 0.2 i_L . This current sharing is accomplished by R_1 , R_2 and D_1 . If the V_{BE} of Q_1 and the V_{on} of D_1 are made equal by design, and i_B is assumed negligible, the voltages across R_1 and R_2 are equal. If R_2 is chosen to be $4R_1$, the current through Q_1 is four times the current through the LM317. The resistor R_3 is included to provide a dc bias path for Q_1 to ensure that the transistor is properly biased.