

isc Silicon PNP Power Transistor

2SB1642

DESCRIPTION

- Collector-Emitter Breakdown Voltage-
: $V_{(BR)CEO} = -60V(\text{Min})$
- Collector Power Dissipation-
: $P_C = 25 W @ T_C = 25^\circ C$
- Low Collector Saturation Voltage-
: $V_{CE(sat)} = -1.5V(\text{Max}) @ (I_C = -2.5A, I_B = -0.25A)$

APPLICATIONS

- Designed for audio frequency power amplifier applications.

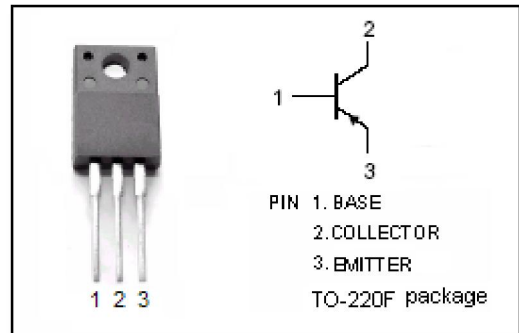

ABSOLUTE MAXIMUM RATINGS($T_a=25^\circ C$)

SYMBOL	PARAMETER	VALUE	UNIT
V_{CBO}	Collector-Base Voltage	-60	V
V_{CEO}	Collector-Emitter Voltage	-60	V
V_{EBO}	Emitter-Base Voltage	-7	V
I_C	Collector Current-Continuous	-4	A
I_B	Base Current-Continuous	-1	A
P_C	Collector Power Dissipation @ $T_a=25^\circ C$	2	W
	Collector Power Dissipation @ $T_C=25^\circ C$	25	
T_J	Junction Temperature	150	$^\circ C$
T_{stg}	Storage Temperature	-55~150	$^\circ C$

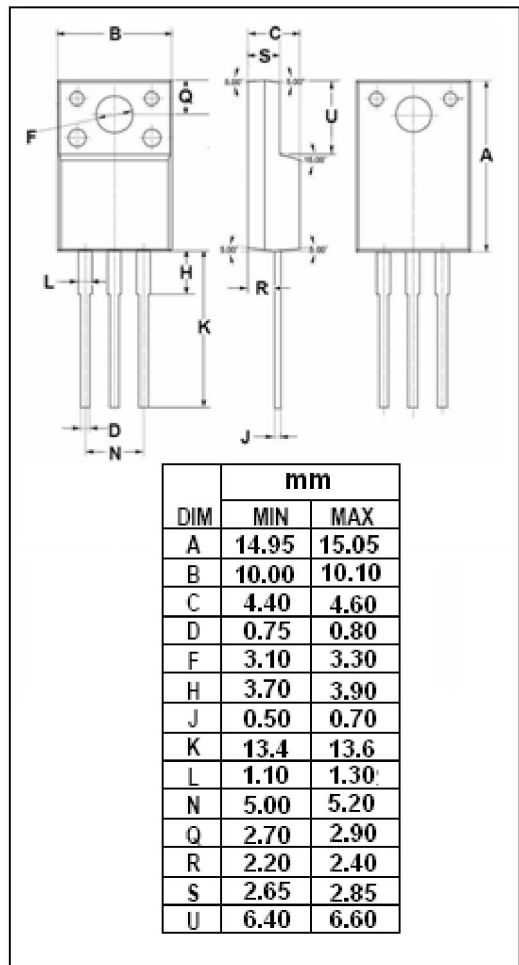

isc Silicon PNP Power Transistor

2SB1642

ELECTRICAL CHARACTERISTICS

T_j=25°C unless otherwise specified

SYMBOL	PARAMETER	CONDITIONS	MIN	TYP.	MAX	UNIT
V _{(BR)CEO}	Collector-Emitter Breakdown Voltage	I _C = -10mA ; I _B = 0	-60			V
V _{CE(sat)}	Collector-Emitter Saturation Voltage	I _C = -2.5A; I _B = -0.25A			-1.5	V
V _{BE(on)}	Base-Emitter On Voltage	I _C = -0.5A ; V _{CE} = -5V			-1.0	V
I _{CBO}	Collector Cutoff Current	V _{CB} = -60V ; I _E = 0			-10	μ A
I _{EBO}	Emitter Cutoff Current	V _{EB} = -7V; I _C = 0			-10	μ A
h _{FE-1}	DC Current Gain	I _C = -0.5A ; V _{CE} = -5V	100		320	
h _{FE-2}	DC Current Gain	I _C = -3A ; V _{CE} = -5V	20			
C _{OB}	Output Capacitance	I _E = 0; V _{CB} = -10V; f _{test} = 1MHz		50		pF
f _T	Current-Gain—Bandwidth Product	I _C = -0.5A ; V _{CE} = -5V		9		MHz