

Befumo AMPS

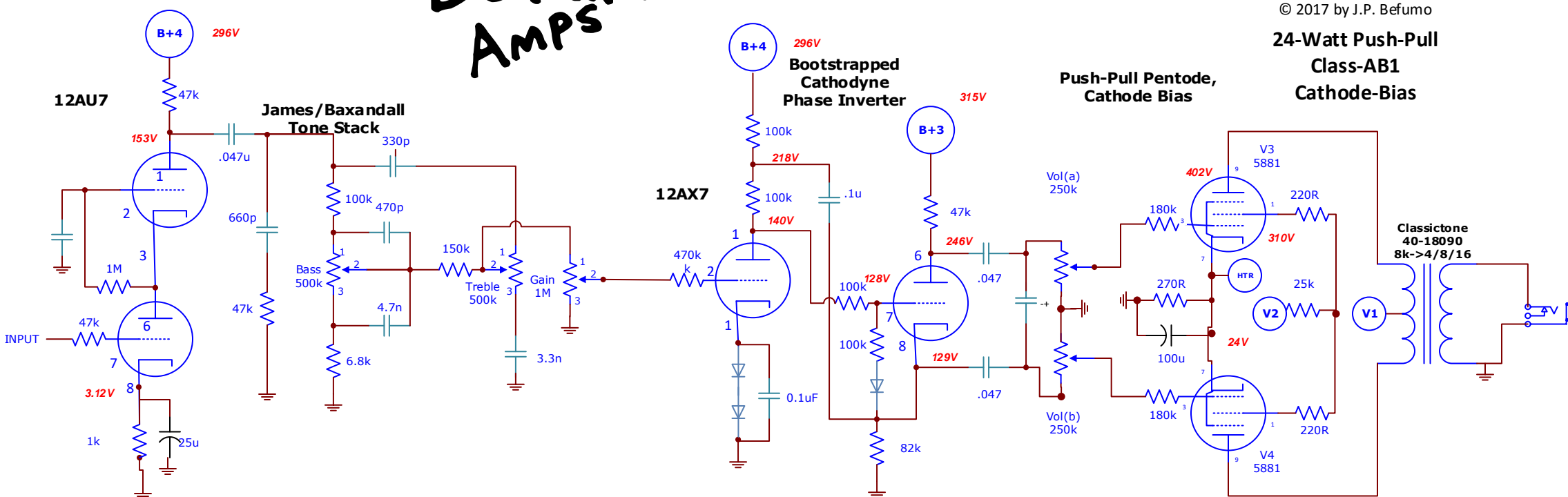

Zero-Signal Plate current: 86.15mA
Zero-Signal Grid #2 Current: 2.85mA
Zero-Signal Plate Dissipation: 16.2W/Tube = 64%
Power Output - 28W (?)

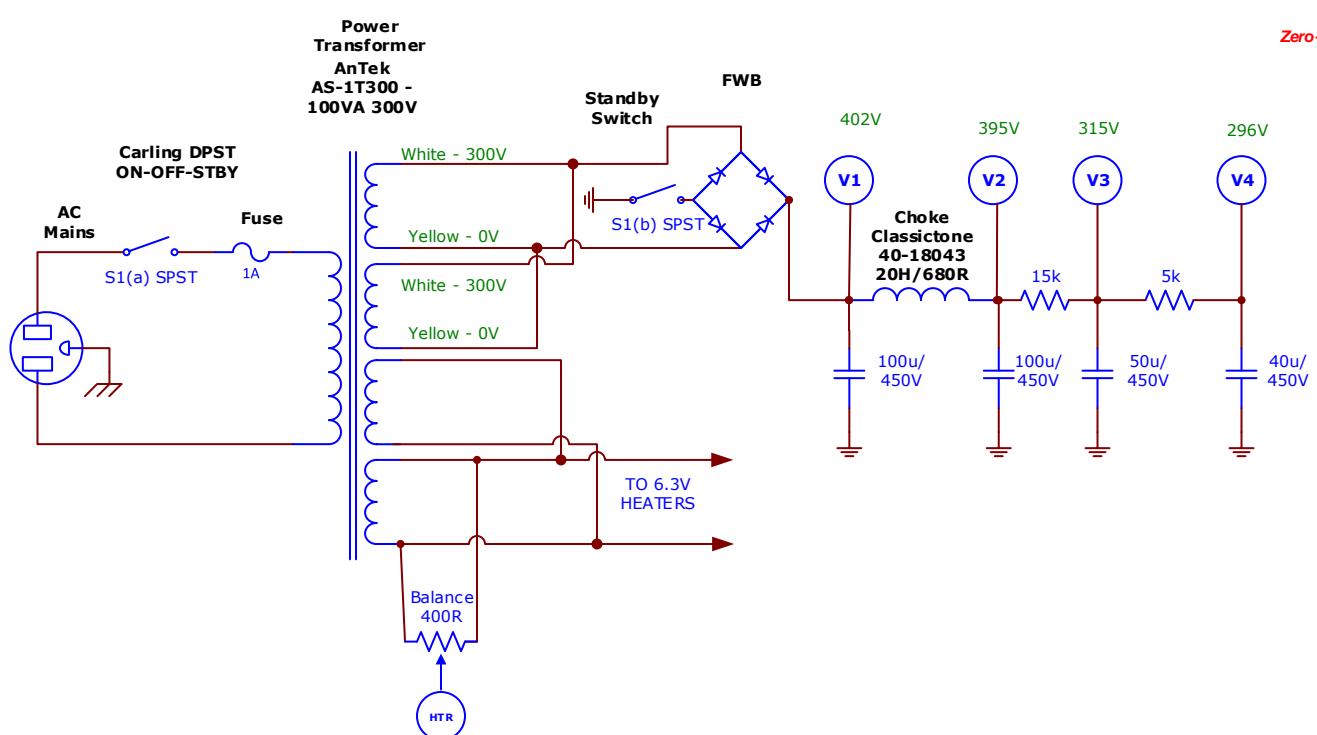

The circuit design presented in this document is the original work of the author, identified below, and is freely distributed under the terms of the Creative Commons Public License Version 4.0

You may use it for individual or commercial purposes, and redistribute it and/or modify it under the terms described in the aforementioned License, either version 4.03 of the License, or (at your option) any later version.
This means that if you use any part of the design, you are required to include acknowledgement of the source and the original author, and if you modify and/or redistribute the original or modified content, it too must be distributed under the same licensing terms.

The design is distributed WITHOUT ANY WARRANTY; including any implied warranty of MERCHANTABILITY or FITNESS FOR A PARTICULAR PURPOSE. See the Creative Commons License (<https://creativecommons.org/licenses/by-sa/4.0/legalcode>) for more details.