



# ICEpower50ASX2(SE) ICEpower50ASX2(BTL) 2x50W or 1x170W ICEpower Amplifiers with integrated ICEpower Supply

Version 1.1

## Contents

---

General Description .....	2
Block Diagram .....	3
Connection Diagram.....	3
Absolute Maximum Ratings .....	5
Power Specifications .....	6
General Audio Specifications (SE-version).....	6
General Audio Specifications (BTL-version).....	7
Electrical Specifications .....	7
Timing Specifications .....	7
Disturbances on the Mains.....	8
Mechanical Specifications .....	8
Typical Performance Characteristics .....	9
Dissipated Power vs. Output Power .....	16
Loading .....	17
Features.....	18
Protection Features .....	20
Input/Output Interface .....	21
Operational Timing Diagram .....	23
Thermal Design.....	23
Physical Dimensions .....	24
Drill Pattern.....	26
Safety Standards.....	27
ESD Warning .....	27
Packaging and Storing.....	27
Notes.....	28

---

## General Description

The ICEpower50ASX2(SE) and ICEpower50ASX2(BTL) are two fully integrated audio power conversion solutions designed particularly for highly competitive consumer and professional audio products. The modules are EMC and safety pre-approved and the "black-box" completeness allows for fast design-in and minimized time to market. Key benefits include:

- State-of-the-art, high efficiency ICEpower amplification stage based on the patented HCOM modulation and MECC control techniques
- An ICEpower Supply with selectable mains converter and separate aux converter.
- A wide set of features for plug-and play implementation into applications such as active speakers and subwoofers, wireless speakers, multimedia audio, musical instrument amplifiers and distributed audio.

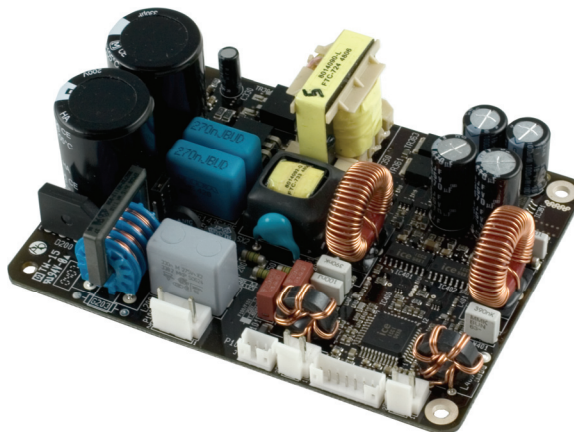

The two output configurations mean that the modules can be used for both stereo and mono applications. Combined with the auxiliary supply for powering external circuitry and the complete elimination of heat sinks and EMI shields; the ICEpower50ASX2 is the natural choice in any audio application that requires a compact, integrated power solution.

The modules are protected against short-circuit, overload and over-heating and includes on-board fuses and EMI filtering to provide a CE and FCC pre-approved design.

### Key Specifications

- 170W @ 4Ω, 1% THD+N, 20Hz – 20kHz (BTL-version)
- 2 x 47W @ 4Ω, 1% THD+N, 20Hz – 20kHz (SE-version, both channels driven)
- 125dBA dynamic range (BTL-version)
- 120dBA dynamic range (SE-version)
- THD+N = 0.003% @ 1W (8Ω, 1kHz, SE)
- THD+N = 0.002% @ 1W (8Ω, 1kHz, BTL)
- 81 % total efficiency @ 170W, 4Ω
- CCIF Intermodulation distortion = 0.0002%, 10W, 4Ω, 18.5kHz/1kHz
- ±25V unregulated auxiliary power supply
- Selectable Mains 85-132V<sub>AC</sub> & 170-264V<sub>AC</sub>

### Key Features

- Fully integrated audio power solution
- Available in two preconfigured output versions
- Rugged construction
- Thermal protection
- Over current protection
- Sound optimized soft clipping
- Suitable for CE approved designs
- EMI conforms to: EN55013  
EN55020  
EN61000-3-2  
EN61000-3-3  
FCC part 15-B
- Safety conforms to: IEC 60065 7<sup>th</sup> ed.  
UL 60065 7<sup>th</sup> ed.

### Block Diagram

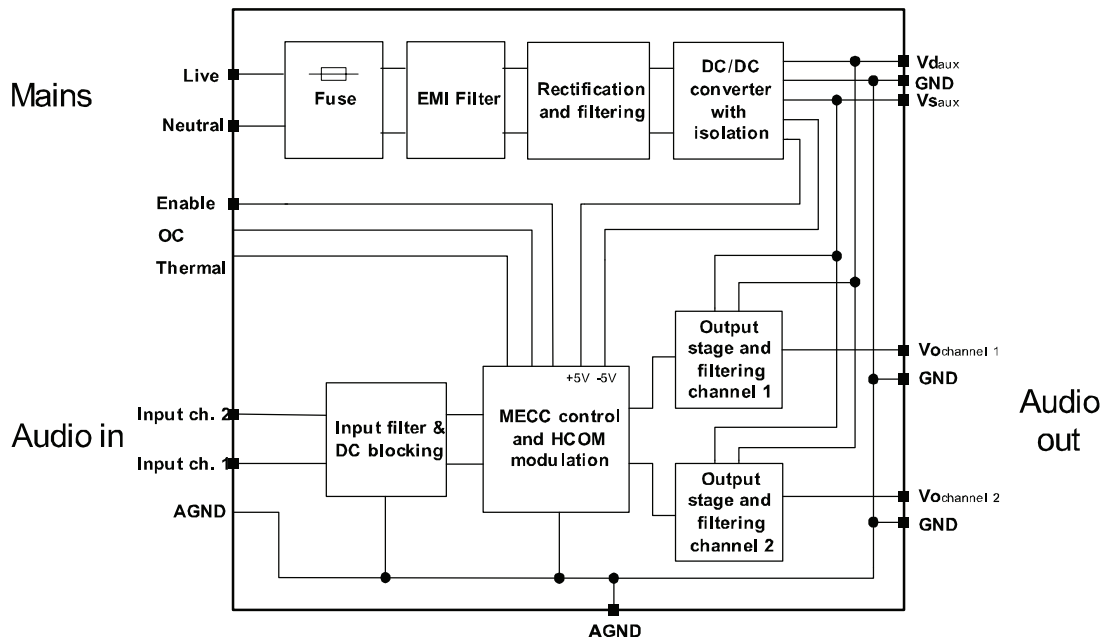

Figure 1: ICEpower50ASX2(SE, BTL) block diagram

### Connection Diagram

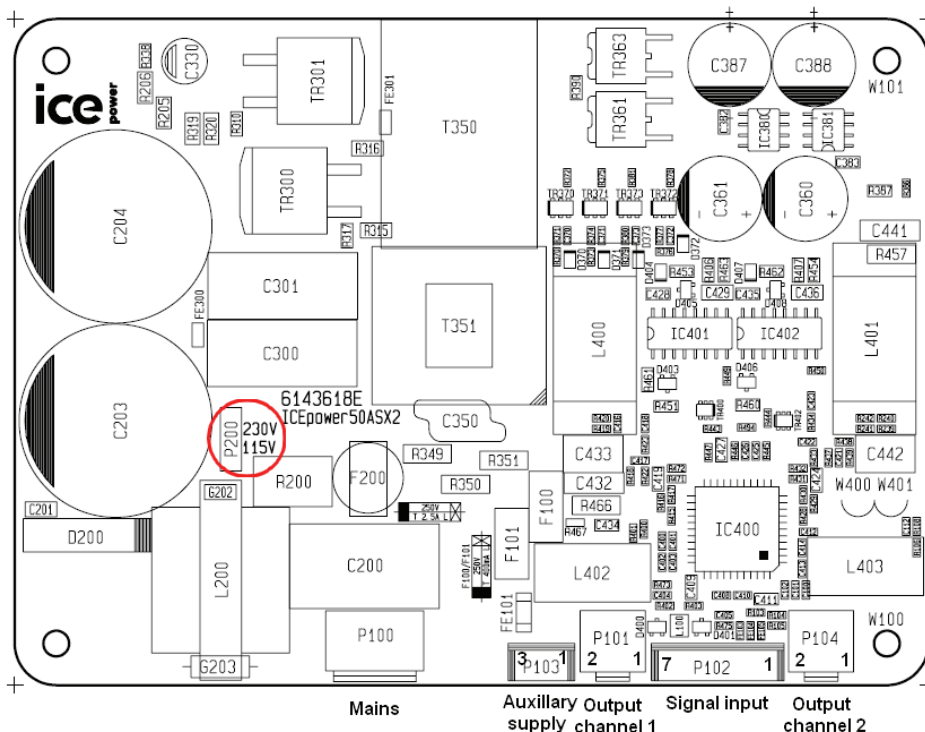

Figure 2: ICEpower50ASX2 connections (SE-version shown).  
 Note: On the BTL-version, connector P101 is not mounted and P104 is used for output.

The connector interface of the ICEpower50ASX2 modules has five industry standard connectors selected for long-term reliability.

### AC Header Specifications (P100)

Type: JST B2P3-VH			
PIN	Function	Description	Type
1	Live	Live AC	Input
2	Neutral	Neutral AC	Input

Table 1: AC connector specifications.

### Speaker Header Specifications (P101)\*

Type: JST B2P-VH			
PIN	Function	Description	Type
1	Vo+	Amplifier output channel 1	Output
2	GND	GND <sub>channel1</sub>	GND

Table 2: Speaker connector specifications.

\*P101 is not mounted on the BTL-version.

### Speaker Header Specifications (P104)

Type: JST B2P-VH			
PIN	Function	Description	Type
1	Vo+	Amplifier output channel 2	Output
2	GND	GND <sub>channel2</sub>	GND

Table 3: Speaker connector specifications.

### Signal Header Specifications (P102)

Type: JST B7B-PH-K-S			
PIN	Function	Description	Type
7	Vin channel 1	Input signal channel 1	input
6	GND	Ground terminal for the signal section.	GND
5	GND	Ground terminal for the signal section.	GND
4	Vin channel 2	Input signal channel 2	Input
3	Thermal	Thermal monitoring pin	Output
2	OC	Monitor pin amplifier over current	Output
1	Enable	Amplifier enable	Input/Output

Table 4: Signal connector specifications.

### Auxiliary Supply Header Specifications (P103)

Type: JST B3B-PH-K-S			
PIN	Function	Description	Type
1	V <sub>d<sub>aux</sub></sub>	Positive unregulated auxiliary supply (typical +25V)	Output
2	GND	Ground terminal for the auxiliary section.	GND
3	V <sub>s<sub>aux</sub></sub>	Negative unregulated auxiliary supply (typical -25V)	Output

Table 5: Auxiliary supply header specifications.

## Absolute Maximum Ratings

Absolute maximum ratings indicate limits beyond which damage may occur.

### Mains Input Section

115V mains setting

Symbol	Parameter	Value	Units
$AC_{max}$	Maximum off-line voltage	132	$V_{AC}$
$AC_{min}$	Minimum off-line voltage	85 <sup>1)</sup>	$V_{AC}$
F	Mains frequency range $85V_{AC} - 132V_{AC}$	45 – 65	Hz

Table 6: Absolute maximum ratings, mains input section - 115V setting.

230V mains setting

Symbol	Parameter	Value	Units
$AC_{max}$	Maximum off-line voltage	264	$V_{AC}$
$AC_{min}$	Minimum off-line voltage	170 <sup>1)</sup>	$V_{AC}$
F	Mains frequency range $170V_{AC} - 264V_{AC}$	45 – 65	Hz

Table 7: Absolute maximum ratings, mains input section - 230V setting.

1) The ICEpower50ASX2 will operate at lower levels but the output power will be reduced. If the off-line voltage is too low the ICEpower50ASX2 switches off.

### Auxiliary Supply

Symbol	Parameter	Value	Unit
$I_{Vd}$	Maximum current draw from Vd (+25V) <sup>2)</sup>	200	mA
$I_{Vs}$	Maximum current draw from Vs (-25V) <sup>2)</sup>	-200	mA

Table 8: Absolute maximum ratings, auxiliary supply.

2) If the auxiliary supply on the ICEpower50ASX2 is used with a capacitive load please remember to read the section "Capacitive Loading of the AUX Supply" in the ICEpower50ASX2 Designer's manual.

### Input Section

Symbol	Parameter	Value	Unit
Vin channel 1 , Vin channel 2	Maximum voltage range on pin	$\pm 3.3$	$V_p$

Table 9: Absolute maximum ratings, input section.

### Output Section

Symbol	Parameter	Value	Units
$R_{load}$	Minimum load	3	$\Omega$
$I_{out}$ <sup>3)</sup>	Maximum current draw from amplifier output	20	A
$C_L$	Maximal pure capacitive loading	470	nF

Table 10: Absolute maximum ratings, output section.

3) The over current protection will act to protect the amplifier. (See "Protection features")

### Thermal Section

Symbol	Parameter	Value	Unit
$T_a$	Max. operating ambient temperature (tropical conditions)	50	$^{\circ}C$

Table 11: Absolute maximum ratings, thermal section.

## Power Specifications

Unless otherwise specified.  $T_a=25\text{ }^\circ\text{C}$ ,  $f=1\text{kHz}$ ,  $R_L=4\Omega$ , 230V mains

Symbol	Parameter	Conditions	Min	Typ	Max	Units
$t_{pmax}$	Time of maximum rated output power	170W out. No preheating.	-	120	-	s
$P_T$	Continuous output power <sup>4)</sup> without thermal shutdown. (SE, $4\Omega$ ) Both channels driven	Thermal stab. @ $T_a = 25\text{ }^\circ\text{C}$ .	-	43	-	W
$P_T$	Continuous output power <sup>4)</sup> without thermal shutdown. (SE, $8\Omega$ ) Both channels driven	Thermal stab. @ $T_a = 25\text{ }^\circ\text{C}$ .	-	30	-	W
$P_T$	Continuous output power <sup>4)</sup> without thermal shutdown. (BTL, $4\Omega$ )	Thermal stab. @ $T_a = 25\text{ }^\circ\text{C}$ .	-	50	-	W
$P_T$	Continuous output power <sup>4)</sup> without thermal shutdown. (BTL, $8\Omega$ )	Thermal stab. @ $T_a = 25\text{ }^\circ\text{C}$ .	-	100	-	W
$P_{SMPS}$	Quiescent power consumption (- amplifier disabled)	Enable pin low	-	4	-	W
$P_q$	Quiescent power consumption (amplifier enabled)	$P_o = 0\text{W}$	-	7	-	W
$\eta$	Total power efficiency	$P_o = 100\text{W}$ $P_o = 170\text{W}$	-	80 81	-	%
$V_{d_{aux}}$ , $V_{s_{aux}}$	Nominal DC voltage	Any combination of mains voltage and output power within specified ranges.	$\pm 16$	$\pm 25$	$\pm 31$	V

Table 12: Power specifications.

4) The module is mounted vertically in free air.

## General Audio Specifications (SE-version)

Unless otherwise specified,  $f=1\text{kHz}$ ,  $P_o=1\text{W}$ ,  $T_a=25\text{ }^\circ\text{C}$ .

Symbol	Parameter	Conditions	Min	Typ	Max	Units
$P_o$	Output power @ 1%THD+N $20\text{Hz} < f < 20\text{kHz}$ , both channels driven. (AES17 measurement filter) <sup>6)</sup>	$R_L = 4\Omega$ $230V_{ac} / 50\text{Hz}$ , $115V_{ac} / 50\text{Hz}$	- -	47 45	- -	W
$P_o$	Output power @ 10%THD+N $20\text{Hz} < f < 20\text{kHz}$ , both channels driven. (AES17 measurement filter) <sup>6)</sup>	$R_L = 4\Omega$ $230V_{ac} / 50\text{Hz}$ , $115V_{ac} / 50\text{Hz}$	- -	57 54	- -	W
$P_o$	Output power @ 1%THD+N $20\text{Hz} < f < 20\text{kHz}$ , one channel driven. (AES17 measurement filter) <sup>6)</sup>	$R_L = 4\Omega$ $230V_{ac} / 50\text{Hz}$ , $115V_{ac} / 50\text{Hz}$	- -	50 50	- -	W
THD+N	THD+N ( $4\Omega$ , AES17 measurement filter) <sup>6)</sup>	$f = 100\text{Hz}$ , $P_o = 1\text{W}$	-	0.003	0.01	%
$V_{N,O}$	Output referenced idle noise	A-weighted	15	25	70	$\mu\text{V}$
$A_v$	Nominal Voltage Gain	$f = 1\text{kHz}$	20	20.5	21	dB
$f$	Frequency response	$20\text{Hz} - 20\text{kHz}$ , All loads	-	$\pm 0.1$	$\pm 0.5$	dB
$f_u$	Upper bandwidth limit (SE) (-3dB)	$R_L = 8\Omega$ $R_L = 4\Omega$	- -	130 95	- -	kHz
$f_l$	Lower bandwidth limit (-3dB)	$R_L = \text{All loads}$	-	1.5	-	Hz
$Z_o$	Abs. output impedance	$f = 1\text{kHz}$	-	14	25	$\text{m}\Omega$
$Z_L$	Load impedance range		3	4	$\infty$	$\Omega$
D	Dynamic range	A-weighted (50W, $4\Omega$ )	-	120	-	dB
IMD	Intermodulation (CCIF)	$f = 18.5\text{kHz}$ , $1\text{kHz}$ , $P_o = 10\text{W}$	-	0.0007	-	%
TIM	Transient intermodulation (DIM30)	$P_o = 10\text{W}$	-	0.007	-	%

Table 13: General audio specifications.

6) An Audio Precision AES17 20 kHz 7<sup>th</sup> order measurement filter is used for measurements. The frequency 6.67 kHz corresponds to the worst-case situation where both 2<sup>nd</sup> and 3<sup>rd</sup> harmonics are within the audio band.

## General Audio Specifications (BTL-version)

Unless otherwise specified,  $f = 1\text{kHz}$ ,  $P_O = 1\text{W}$ ,  $T_a = 25^\circ\text{C}$ .

Symbol	Parameter	Conditions	Min	Typ	Max	Units
$P_O$	Output power @ 1%THD+N 20Hz < f < 20kHz (AES17 measurement filter) <sup>6)</sup>	$R_L = 4\Omega$ 230V <sub>ac</sub> /50Hz, 115V <sub>ac</sub> /50Hz	- -	170 150	- -	W
$P_O$	Output power @ 10%THD+N 20Hz < f < 20kHz (AES17 measurement filter) <sup>6)</sup>	$R_L = 4\Omega$ 230V <sub>ac</sub> /50Hz, 115V <sub>ac</sub> /50Hz	- -	220 180	- -	W
THD+N	THD+N in 4Ω (AES17 measurement filter) <sup>6)</sup>	f = 100Hz, $P_O = 1\text{W}$	-	0.002	0.005	%
$V_{N,O}$	Output referenced idle noise	A-weighted 20Hz < f < 20kHz	15	20	70	μV
$A_V$	Nominal Voltage Gain	f = 1 kHz	26	27	28	dB
f	Frequency response	20Hz - 20kHz, All loads	-	±0.2	±0.6	dB
$f_u$	Upper bandwidth limit (BTL) (-3dB)	$R_L = 8\Omega$ $R_L = 4\Omega$	- -	100 75	- -	kHz kHz
$f_l$	Lower bandwidth limit (-3dB)	$R_L = \text{All loads}$	-	1.5	-	Hz
$Z_o$	Abs. output impedance	f = 1kHz	-	18	30	mΩ
$Z_L$	Load impedance range		3	4	∞	Ω
D	Dynamic range	A-weighted at 170W@4Ω	-	125	-	dB
IMD	Intermodulation (CCIF)	f = 18.5kHz, 1kHz, $P_O = 10\text{W}$	-	0.0002	-	%
TIM	Transient intermodulation (DIM30)	$P_O = 10\text{W}$	-	0.003	-	%

Table 14: General audio specifications.

<sup>6)</sup> An Audio Precision AES17 20 kHz 7<sup>th</sup> order measurement filter is used for measurements. The frequency 6.67 kHz corresponds to the worst-case situation where both 2<sup>nd</sup> and 3<sup>rd</sup> harmonics are within the audio band.

## Electrical Specifications

Unless otherwise specified,  $T_a = 25^\circ\text{C}$ .

Symbol	Parameter	Conditions	Min	Typ	Max	Unit
$f_o$	Idle switching frequency	Idle	500	550	600	kHz
$f_s$	Switching frequency range (amplifier)	Idle to full scale variation	90	-	600	kHz
$f_{smps}$	Switching frequency (power supply)		-	100	-	kHz

Table 15: Electrical specifications.

## Timing Specifications

Symbol	Parameter	Conditions	Min	Typ	Max	Unit
$t_{acd}$	Power supply start up delay. (nominal mains)	Time from reaching AC <sub>min</sub> to all power supplies are good and amplifier is active.	-	700	1000	ms

Table 16: Timing specifications.

## Disturbances on the Mains

The signal on the mains connection is often very noisy and large surge voltages are present. The ICEpower50ASX2 is equipped with mains filtering to suppress surges and noise.

## Lightning

To avoid damage of the ICEpower50ASX2 in case of surges caused by lightning, special care and component selection have resulted in capability of withstanding surges up to 5.5kV.

## Mechanical Specifications

During development the ICEpower50ASX2 has passed tough mechanical tests to ensure high reliability.

Test	Acceleration	Amount
Unpowered tests: The unit is powered after the test to verify functionality.		
Random vibration	2g <sub>RMS</sub>	3x20min
Bump	10g/16ms, 2-4 Hz	1000 bumps in each of 6 directions <sup>7)</sup>
Shock	70g/12ms	3 shocks in each of 6 directions <sup>7)</sup>
Powered tests: The unit is tested with power applied.		
Sinusoidal vibrations	2.5mm, 5-10Hz 1g, 10-100Hz	2 hours in each of 3 directions <sup>7)</sup>
Random vibrations	0.01g, 10-20Hz 0.7g <sub>RMS</sub> -3dB/oct, 20-150Hz	2 hours in each of 3 directions <sup>7)</sup>

Table 17: Mechanical tests.

7) 6 directions: (up, down, left, right forward and backward). 3 directions: (up and down, left and right, forward and backward)



## Typical Performance Characteristics

### Frequency Response (SE-version)

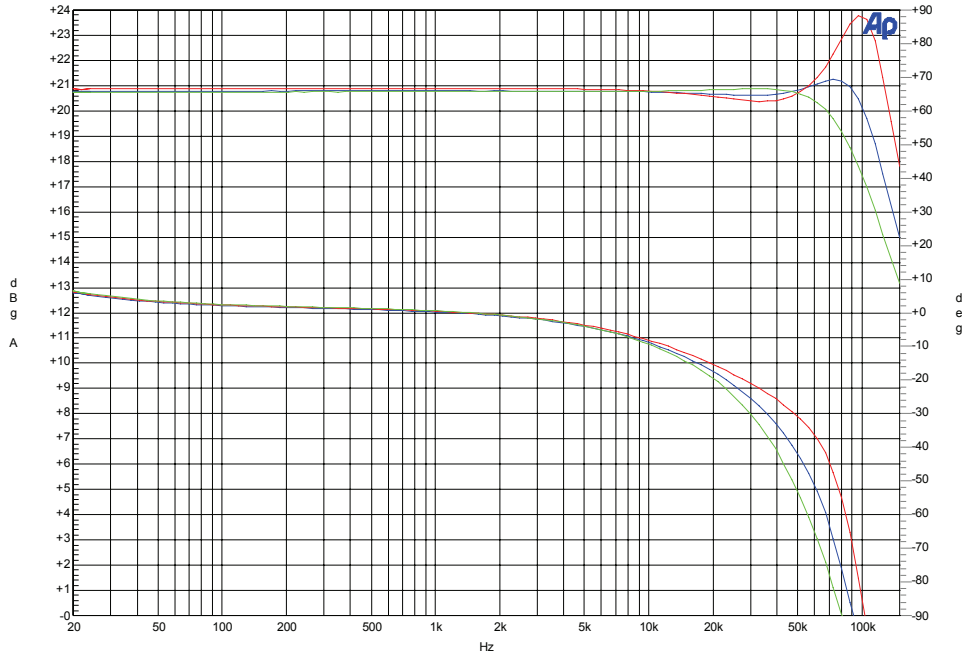

Figure 3: Frequency response in 4Ω (green), 8Ω (blue) and open load (red). Top – amplitude. Bottom – phase.

### Frequency Response (BTL-version)

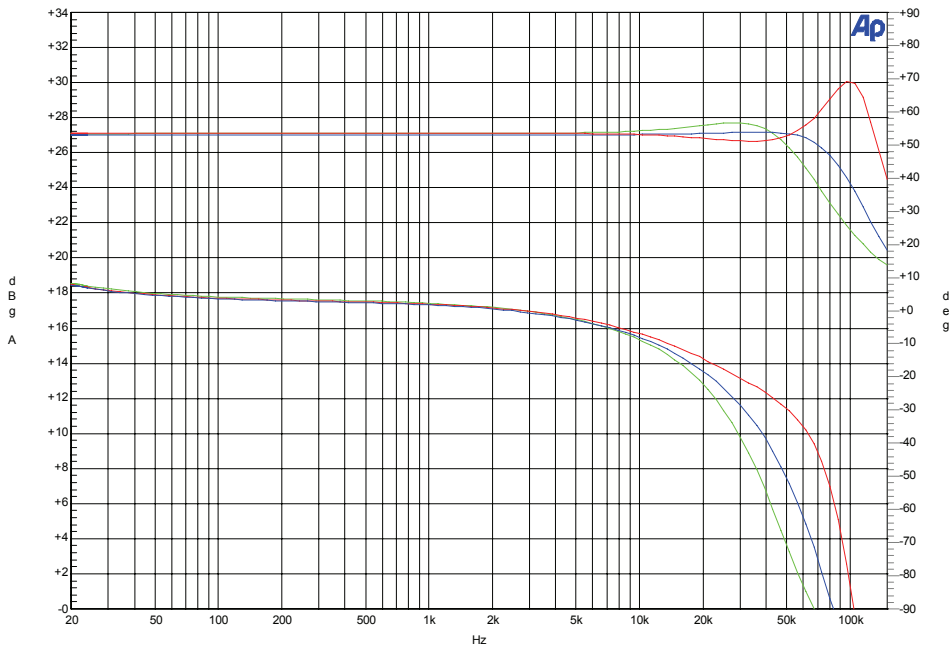
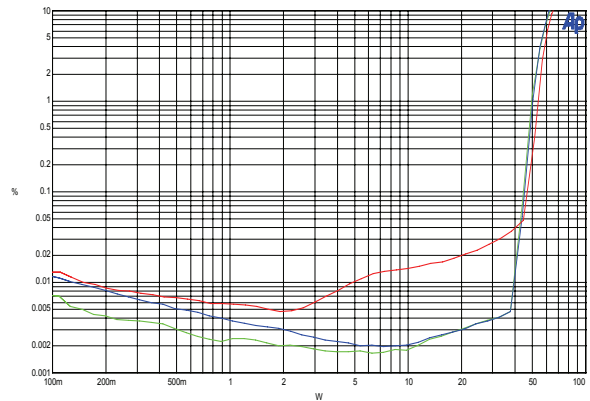
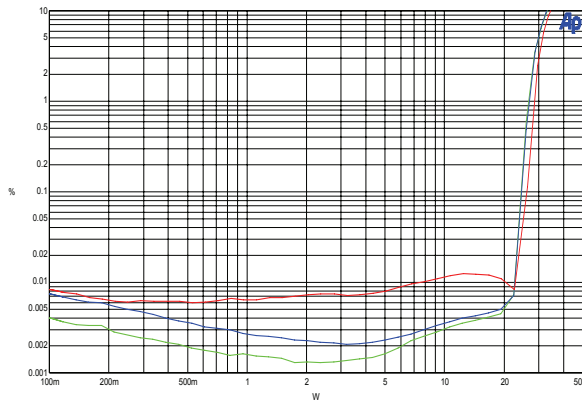

Figure 4: Frequency response in 4Ω (green), 8Ω (blue) and open load (red). Top – amplitude. Bottom – phase.

**Harmonic Distortion & Noise (SE-version)**



THD+N vs. Po at 100Hz, 1kHz and 6.67kHz<sup>8)</sup> (8Ω), 230Vac/50Hz

THD+N vs. Po at 100Hz, 1kHz and 6.67kHz<sup>8)</sup> (4Ω), 230Vac/50Hz

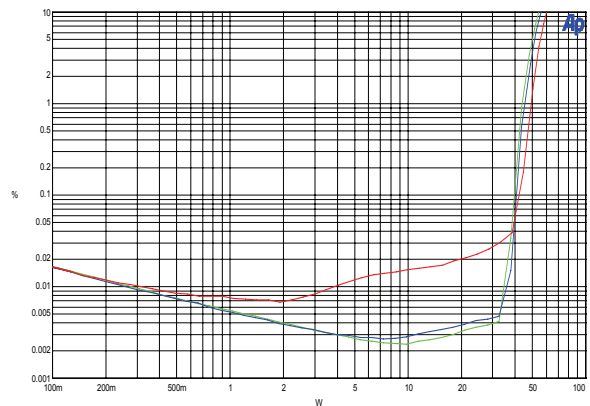
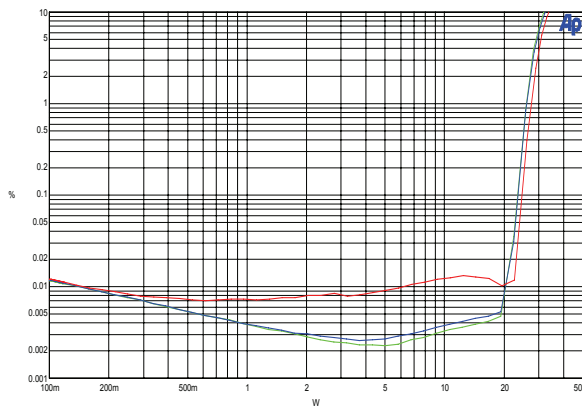

THD+N vs. Po at 100Hz, 1kHz and 6.67kHz<sup>8)</sup> (8Ω), 115Vac/50Hz

THD+N vs. Po at 100Hz, 1kHz and 6.67kHz<sup>8)</sup> (4Ω), 115Vac/50Hz

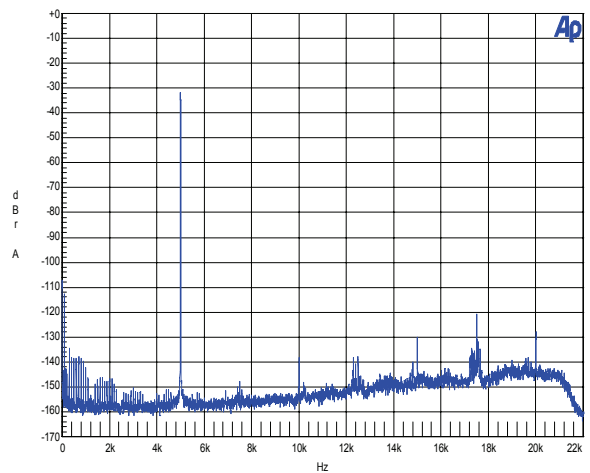
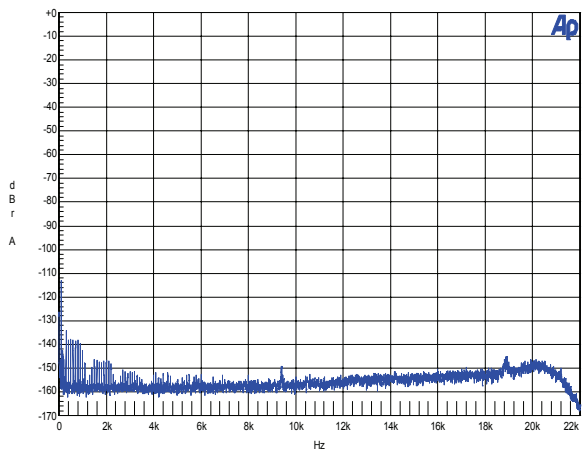

Idle noise (16K FFT). Residual = 25µV(A).  
(Relative to 50W into 4 ohm)

f = 5kHz. Po = 100mW. 4Ω loading.  
(Relative to 50W into 4 ohm)

Figure 5: Total harmonic distortion & noise (SE).

8) An Audio Precision AES17 20 kHz 7<sup>th</sup> order measurement filter is used for measurements. The frequency 6.67 kHz corresponds to the worst-case situation where both 2<sup>nd</sup> and 3<sup>rd</sup> harmonics are within the audio band.

**Harmonic Distortion & Noise (BTL-version)**

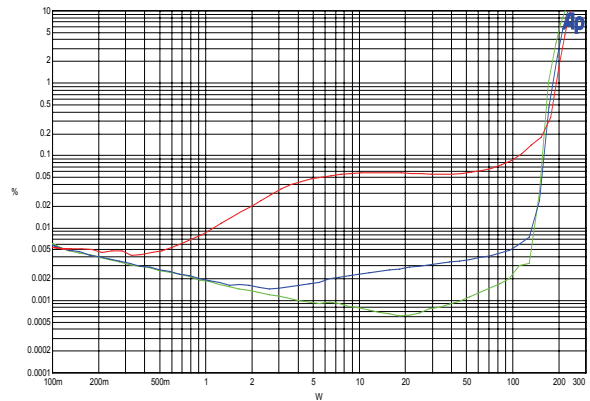
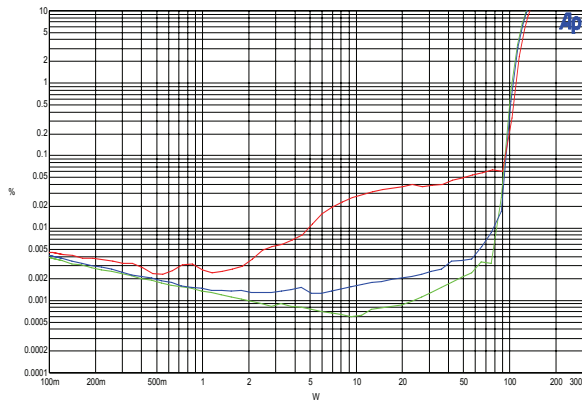

THD+N vs. Po at 100Hz, 1kHz and 6.67kHz<sup>8)</sup> (8Ω), 230Vac/50Hz

THD+N vs. Po at 100Hz, 1kHz and 6.67kHz<sup>8)</sup> (4Ω), 230Vac/50Hz

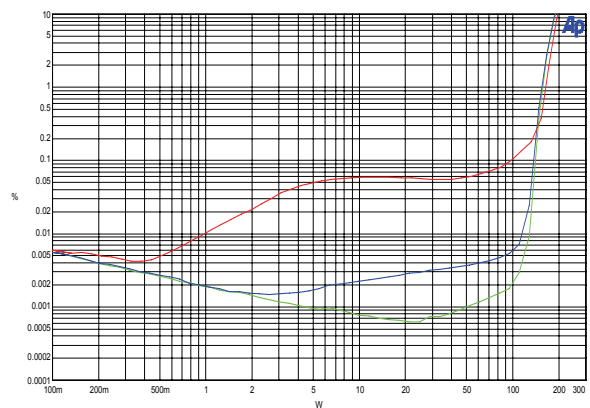
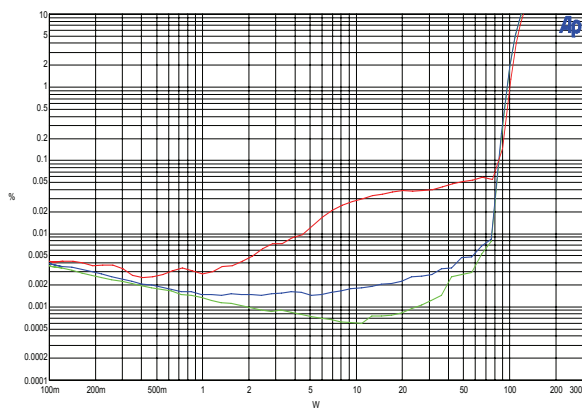

THD+N vs. Po at 100Hz, 1kHz and 6.67kHz<sup>8)</sup> (8Ω), 115Vac/50Hz

THD+N vs. Po at 100Hz, 1kHz and 6.67kHz<sup>8)</sup> (4Ω), 115Vac/50Hz

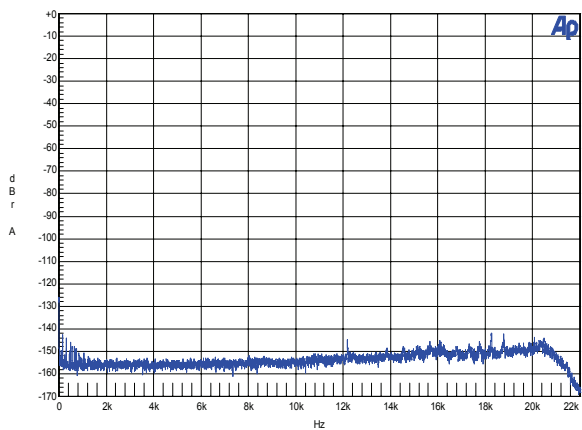

Idle noise (16K FFT). Residual = 25μV(A).  
(Relative to 170W into 4 ohm)

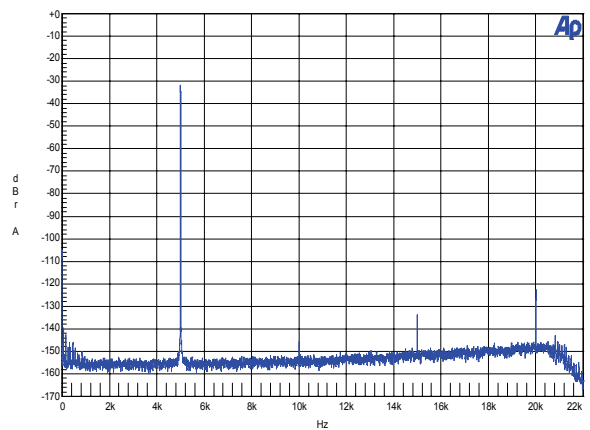

f = 5kHz. Po = 100mW. 4Ω loading.  
(Relative to 170W into 4 ohm)

Figure 6: Total harmonic distortion & noise (BTL).

8) An Audio Precision AES17 20 kHz 7<sup>th</sup> order measurement filter is used for measurements. The frequency 6.67 kHz corresponds to the worst-case situation where both 2<sup>nd</sup> and 3<sup>rd</sup> harmonics are within the audio band.

**Intermodulation Distortion (CCIF & TIM) (SE-version)**

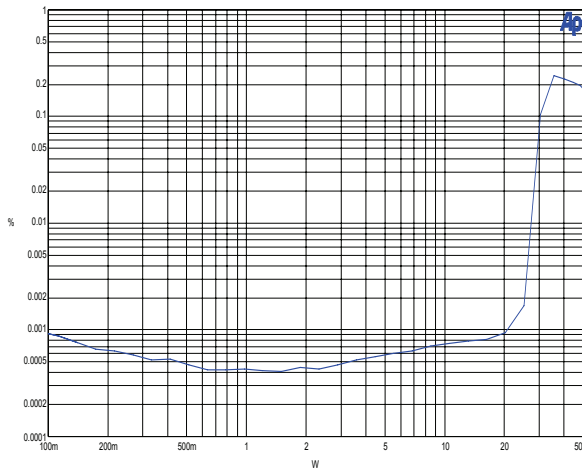

CCIF IMD vs.  $P_O$ ,  $R_L = 4\Omega$ ,  $f_1 = 18,5\text{kHz}$ ,  $f_2 = 1\text{kHz}$ ,  
 $\text{IMD}@10\text{W} = 0.0007\%$ .

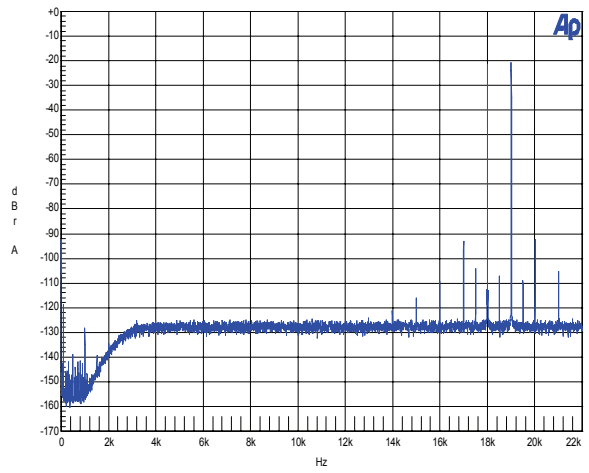

CCIF IMD analysis.  $R_L = 4\Omega$ ,  $P_O = 10\text{W}$ .

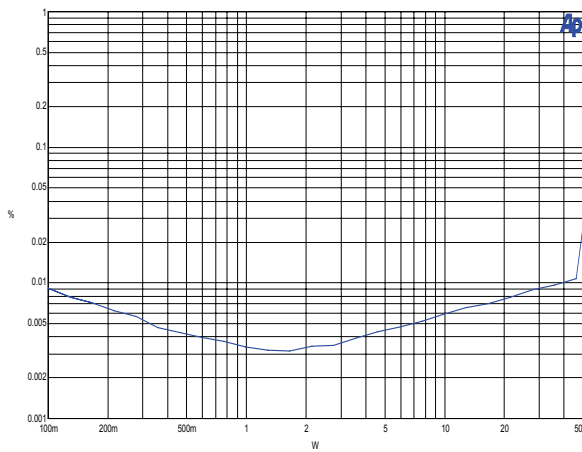

TIM vs. output power.  $R_L = 4\Omega$ ,  
 $\text{TIM}@10\text{W} = 0.007\%$

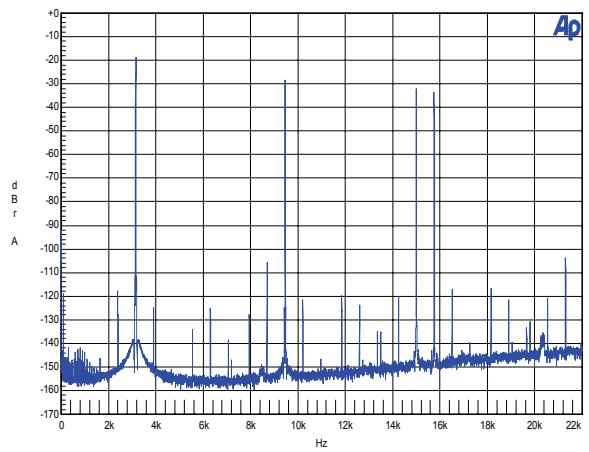

TIM FFT analysis.  $R_L = 4\Omega$ ,  $P_O = 10\text{W}$ .

Figure 7: Intermodulation distortion (SE).

**Intermodulation Distortion (CCIF & TIM) (BTL-version)**

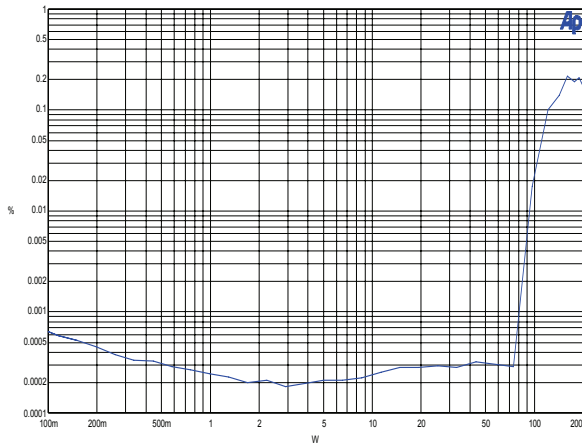

CCIF IMD vs.  $P_o$ ,  $R_L = 4\Omega$ ,  $f_1 = 18.5\text{kHz}$ ,  $f_2 = 1\text{kHz}$ ,  
 IMD@10W = 0.0002%.

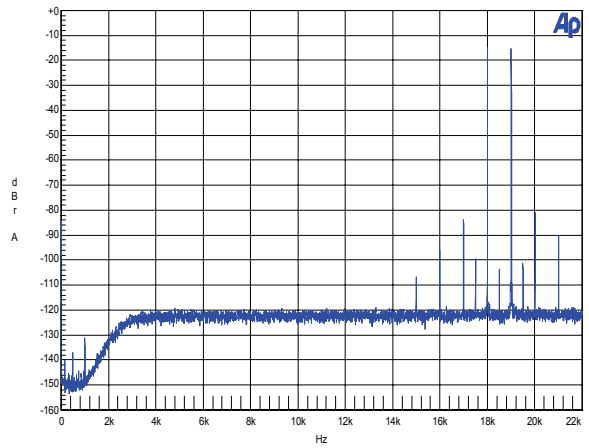

CCIF IMD analysis.  $R_L = 4\Omega$ ,  $P_o = 10\text{W}$ .

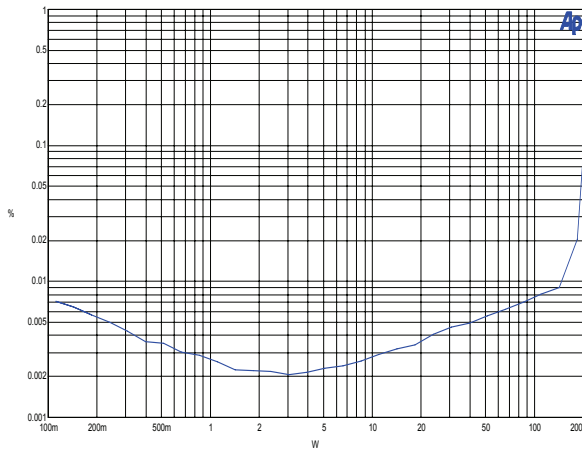

TIM vs. output power.  $R_L = 4\Omega$ ,  
 TIM@10W = 0.003%

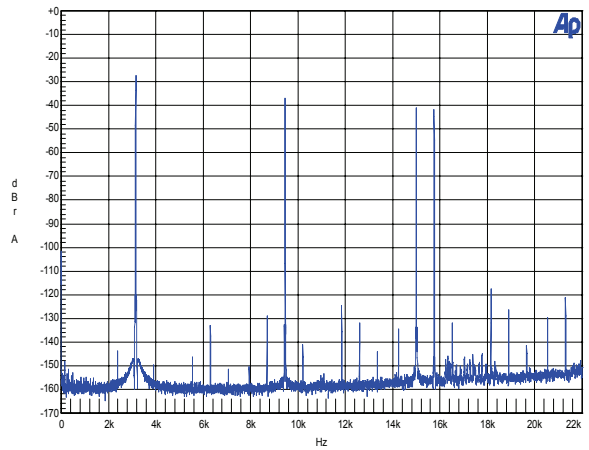

TIM FFT analysis.  $R_L = 4\Omega$ ,  $P_o = 10\text{W}$ .

Figure 8: Intermodulation distortion (BTL).

### Power vs. Frequency

Due to the compensating Zobel network in the output stage, the maximum allowable short-term output power is frequency-dependant. The short-term output power is defined as the maximum undistorted (THD+N < 1%) output power until thermal shutdown occurs. The maximum Full Power Bandwidth is 20 kHz. Above this frequency the Zobel protection circuit may briefly shutdown the amplifier to protect the Zobel network from damage.

Note that this limitation will never cause any problems when the amplifier is fed a music signal at the input, but the limit must be taken into consideration when the amplifier is tested under laboratory conditions using sine waves or noise signals.

### Output impedance

The output impedance is measured by feeding 1A<sub>RMS</sub> into the output of the amplifier and measuring the voltage on the output. The voltage then corresponds to the output impedance. The output impedance is measured directly on the terminals on the PCB.

The figure below shows the output impedance from 100Hz – 20kHz for the SE-version.

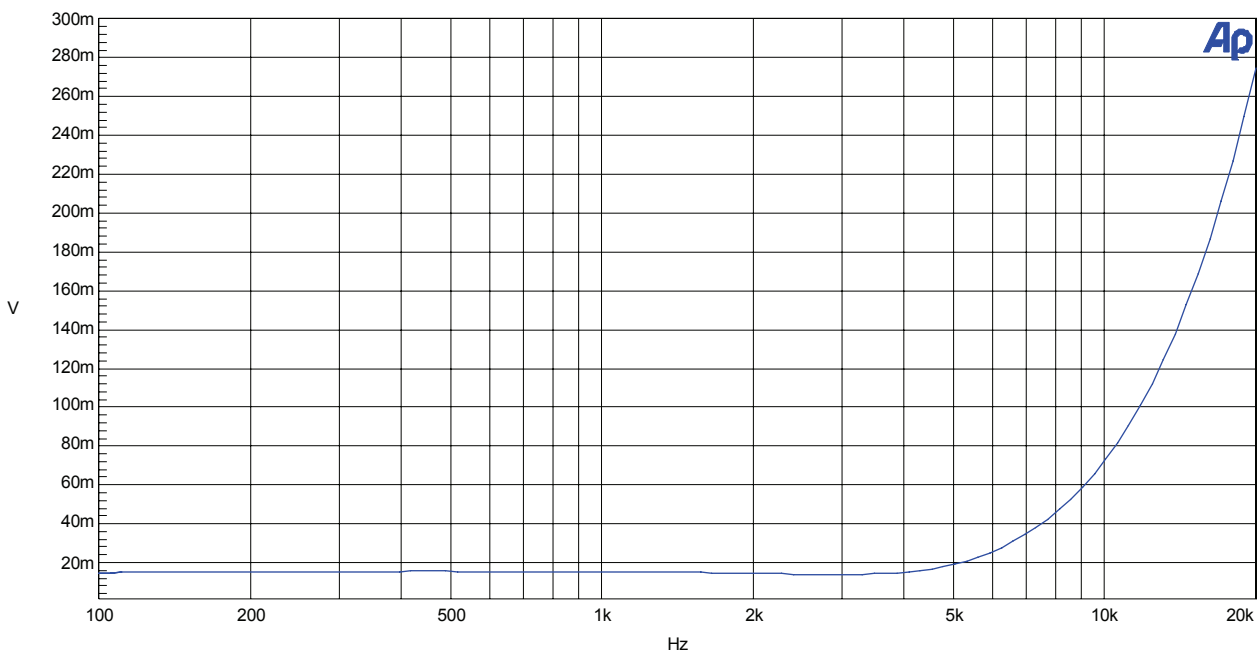

Figure 9: Measured voltage at output terminals while feeding 1A<sub>RMS</sub> into the output of the amplifier at PCB.

The figure below shows the output impedance from 100Hz – 20kHz for the BTL-version.

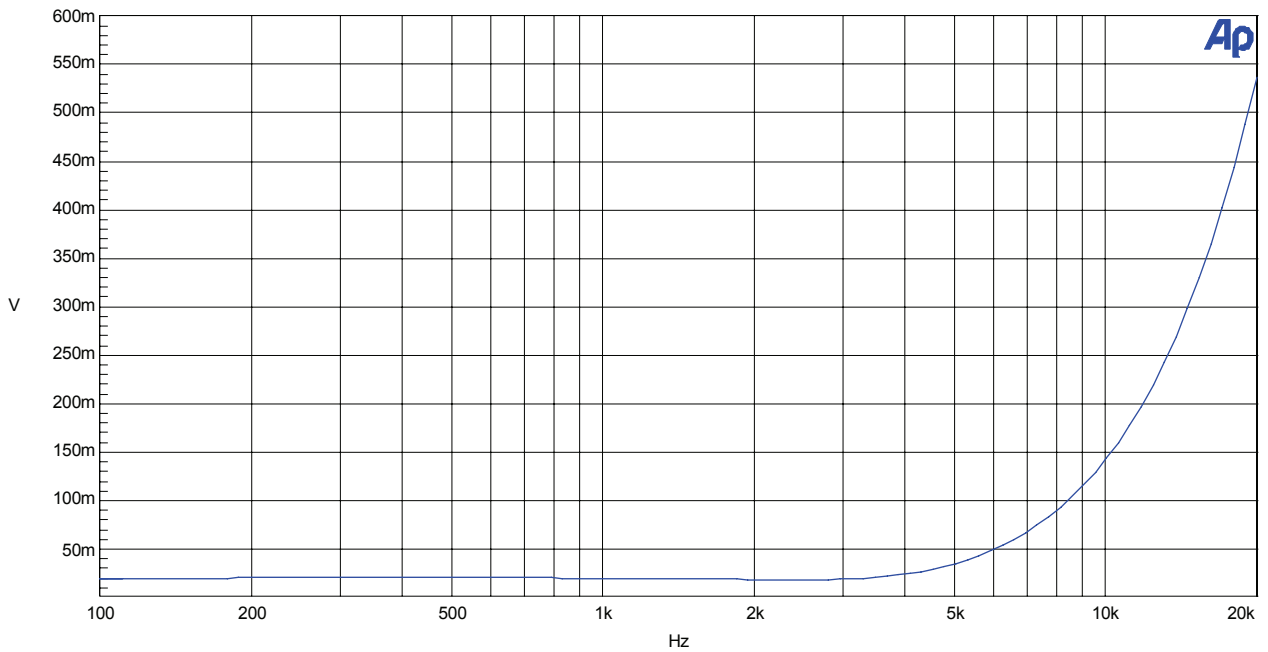

Figure 10: Measured voltage at output terminals while feeding 1ARMS into the output of the amplifier at PCB.

## Dissipated Power vs. Output Power

### SE-version

Mains Voltage  $V_{IN}$ : 115V/50Hz

<i>SE-version</i>	Load impedance [ $\Omega$ ]	Rated power [W]	Line power [W]	Output power (both channels) [W]	Dissipated power [W]
Idle			7		7
1/8 rated power (pink noise)	4	45	21	2 x 6	9
1/8 rated power (pink noise)	8	25	13	2 x 3	7
Continuous output power	4	43	104	2 x 43	18
Continuous output power	8	25	60	2 x 25	10

Mains Voltage  $V_{IN}$ : 230V/50Hz

<i>SE-version</i>	Load impedance [ $\Omega$ ]	Rated power [W]	Line power [W]	Output power (both channels) [W]	Dissipated power [W]
Idle			7		7
1/8 rated power (pink noise)	4	47	21	2 x 6	9
1/8 rated power (pink noise)	8	27	13	2 x 3	7
Continuous output power	4	43	105	2 x 43	19
Continuous output power	8	27	63	2 x 27	9

Table 18: Dissipated power vs. Output power (SE).



BTL power dissipation

Mains Voltage  $V_{IN}$ : 115V/50Hz

<i>BTL-version</i>	Load impedance [ $\Omega$ ]	Rated power [W]	Line power [W]	Output power [W]	Dissipated power [W]
Idle			7		7
1/8 rated power (pink noise)	4	150	30	19	11
1/8 rated power (pink noise)	8	95	20	12	8
Continuous output power	4	50	66	50	16
Continuous output power	8	95	113	95	18

Mains Voltage  $V_{IN}$ : 230V/50Hz

<i>BTL-version</i>	Load impedance [ $\Omega$ ]	Rated power [W]	Line power [W]	Output power [W]	Dissipated power [W]
Idle			7		7
1/8 rated power (pink noise)	4	170	32	21	11
1/8 rated power (pink noise)	8	100	21	13	8
Continuous output power	4	50	66	50	16
Continuous output power	8	100	116	100	16

Table 19: Dissipated power vs. Output power (BTL).

**Loading**

With its low output impedance, the ICEpower50ASX2 is designed to be unaffected by loudspeaker loading characteristics. However, care should be taken with *purely* capacitive loads.

Traditionally amplifiers have been tested extensively in laboratories with purely capacitive loads. This was done to test the amplifier's stability and performance but it does not relate to any normal speaker load as even electrostatic speakers do not present a purely capacitive load to the amplifier but include a resistive part as well. The maximum purely capacitive load allowed is 470nF.

## Features

The ICEpower50ASX2 has a number of useful features as described below.

### Over Current monitor pin

Figure 11 shows the internal circuit of the OC pin interface. This pin is high (+5V) under normal conditions. If a short circuit is detected on the speaker output terminals the pin is pulled low (0V). This pin is also activated by other protection features such as Zobel protection, saturation detection and DC protection on the output. If any of these protection features are activated, the pin will be pulled low (0V). This pin is only an output.

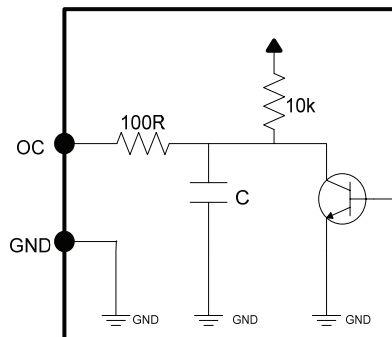

Figure 11: Over Current monitor pin interface.

### Thermal monitor pin

Figure 12 shows the internal circuit of the thermal pin interface. This pin is high (+5V) under normal conditions. If the amplifier temperature becomes too high the pin is pulled low (0V). This can happen if the continuous power drawn from the amplifier exceeds the limits listed on p. 6 and p. 7. This pin is only an output.

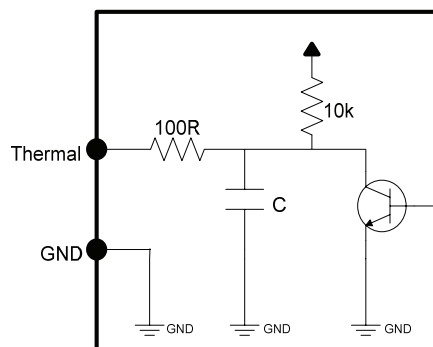

Figure 12: Thermal monitor pin interface.

### Enable pin

The enable pin can enable/disable the amplifier. If the pin is left unconnected then the level is high (+5V), and the amplifier is enabled. If the pin is pulled low (0V) externally, the amplifier will be disabled.

The enable pin will also be pulled low by the internal protection circuitry if the amplifier temperature becomes too high or a mains under-voltage is detected. This pin is bidirectional.

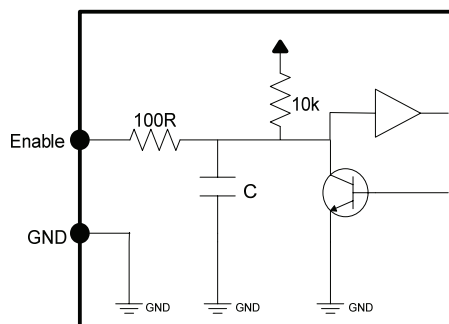

Figure 13: Enable pin interface.

**Auxiliary Power Supply**

The auxiliary supply can be used to power an external circuit such as a preamplifier or an equalizer/crossover. Remember that this supply is unregulated.

When using this AUX supply, please remember to read the sections "Shielding and Grounding of Audio Signals" and "Capacitive Loading of the Aux Supply" in the ICEpower50ASX Designer's Manual.

**NOTE:**

The Vd and Vs outputs are fused. Even brief overload or short circuit will blow the fuses!

To maintain long term power handling and the effects of inrush current, the fuses on the module are 400mA types. To ensure no unexpected burning of the fuse, the maximum output current drawn from the aux supply should not exceed 200mA.

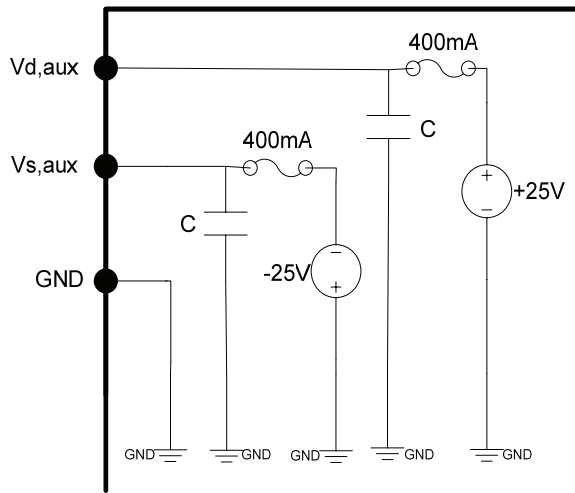

Figure 14: Auxiliary supply equivalent diagram.

### Protection Features

The ICEpower50ASX2 is equipped with several protection features for surviving overload without damage. The block diagram below illustrates the different protection features.

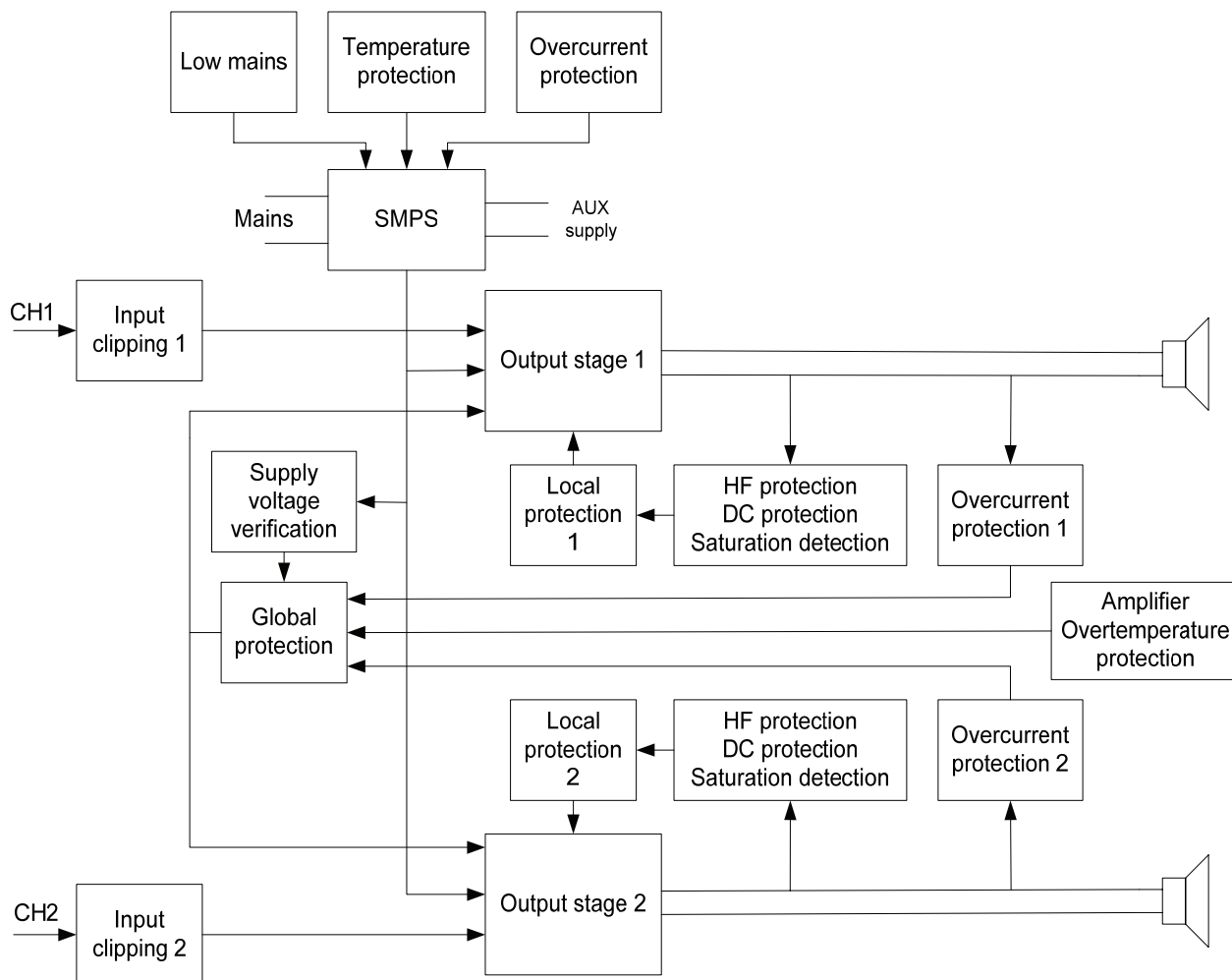

Figure 15: Protection schematic

### Power Supply Protection

The power supply of the ICEpower50ASX has 2 protection circuits; overtemperature and overcurrent.

The temperature protection will be activated if the absolute temperature of the circuit is too high. This can be caused by high ambient temperature, high load (amplifier and AUX supply) for a long time or a combination of these two parameters.

The over current protection will be activated if the output current to amplifier and AUX is too large. Please remember that the AUX supply is protected by fuses.

If one of these protection features is triggered, the power supply either limits its output power or shuts down. In case of a shut down the power supply will rapidly try to restart if the circuit’s temperature is OK.

### Amplifier Local Protection

The ICEpower50ASX2 has a local protection circuit for each of the two audio channels. This local protection handles HF protection, DC protection and saturation detection. If one of these protections features becomes active on one channel it will only influence on the channel where the error occurred.

The HF protection circuit is implemented to protect the Zobel network against ultrasonic signals (greater than 20kHz). This protection circuit has a build-in time constant, so it is possible to deliver a high frequency, high amplitude signal for a short time.

### Amplifier Global Protection

There is two global protection features in the 50ASX2 amplifier; an over temperature protection and an over current protection.

The over temperature protection will only occur if the  $P_{RMS}$  is greater that the specified Continuous Output Power. In normal use the amplifier will not shut down if properly mounted.

The over current detection circuit is included in the ICEpower chipset by detecting saturation of the control system. This condition will typically be allowed in 100ms to 500ms which is enough to avoid accidental shutdown at peak currents during high music output. The current limit is set to 20A.

## Input/Output Interface

### Input Stage

The single ended input buffer has an anti-aliasing filtering and a DC capacitor. The input impedance of the signal input section is minimum  $8k\Omega$  over the audio bandwidth, which is an acceptable loading condition for pre-amps, active crossover outputs etc.

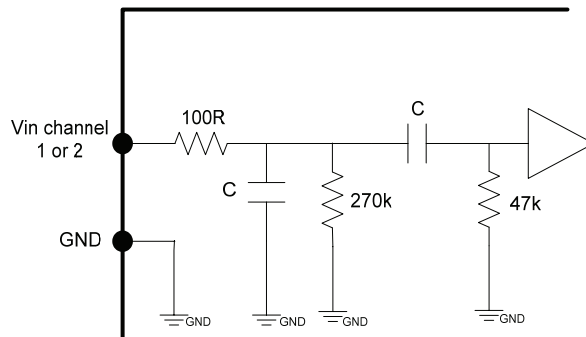

Figure 16: Single ended input buffer.

**BTL module setup:**

When using the BTL module the wiring diagram on fig. 17 should be followed. Note that it is the channel 2 speaker terminal which is used on the BTL module (the channel 1 terminal is not mounted on the board).

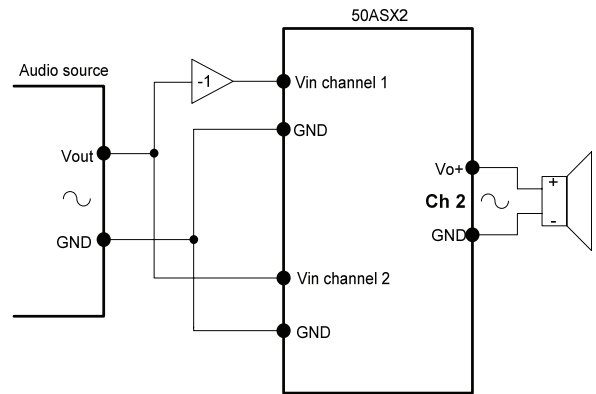

Figure 17: Wiring diagram for the BTL module

**Output stage**

The output stage is a half bridge topology with a 2<sup>nd</sup> order filter. The filter design is a part of ICEpower’s proprietary MECC topology and has been chosen as the optimal solution between demodulation characteristics, efficiency and filter compactness. The essential output characteristics are:

- The switching residual on the output primarily consists of a single frequency component at the carrier fundamental  $f_s$ .

The system bandwidth is 130 kHz in 8Ω (SE) and 100 kHz in 8Ω (BTL).

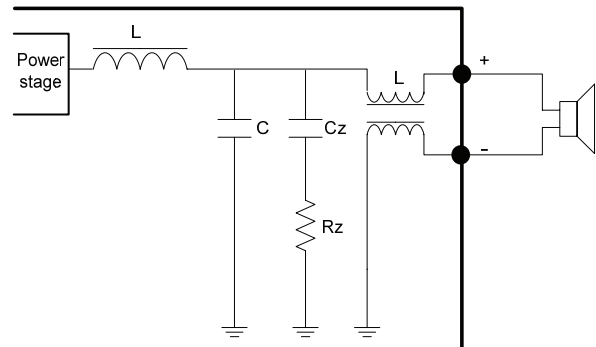

Figure 18: SE output filter section with compensating Zobel network.

## Operational Timing Diagram

The following diagram show selected signals during power up/down (nominal mains).

### Timing for changes in mains and enable levels

1. 700ms typ.
2. 2ms typ.
3. 100us typ.
4. 2ms typ.
5. 1200ms max. (load/power dependent)
6. 50ms typ.

OC and Thermal pins have the same response delays as the Enable pin from when the OC or thermal error is detected.

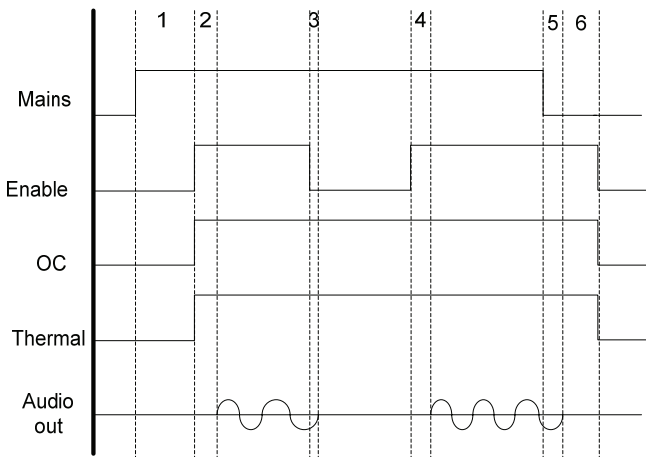

Figure 19: Timing – enable and mains.

## Thermal Design

Thermal design is generally a great challenge in power amplifier systems. Linear amplifier designs operating in class A or AB are normally very inefficient and therefore equipped with extensive heat sinking to keep the transistor junction temperature low. The ICEpower50ASX2 is based on highly efficient ICEpower switching technology providing high overall efficiency characteristics at all levels of operation.

Part of the “component” philosophy of the ICEpower50ASX2 module is to provide a self-cooled component thus eliminating the need for special attention to thermal design.

The ICEpower50ASX module is designed for music reproduction, which means that the output power of the amplifier will never be continuous. Research has shown that the RMS level of any music signal does not normally exceed 1/8<sup>th</sup> of the peak value and the power supply is therefore designed for large short-term power handling and lower continuous power handling. If the average output power of the ICEpower50ASX exceeds 43W @ 4Ω (SE-mode with both channels driven) or 50W @ 4Ω (BTL-mode) for a long time at 25°C ambient temperature, the module will reach its maximum allowable temperature and the temperature protection will be activated.

Further information about thermal design can be found in the ICEpower ASX Designers Manual.

### Physical Dimensions

All dimensions are in mm.

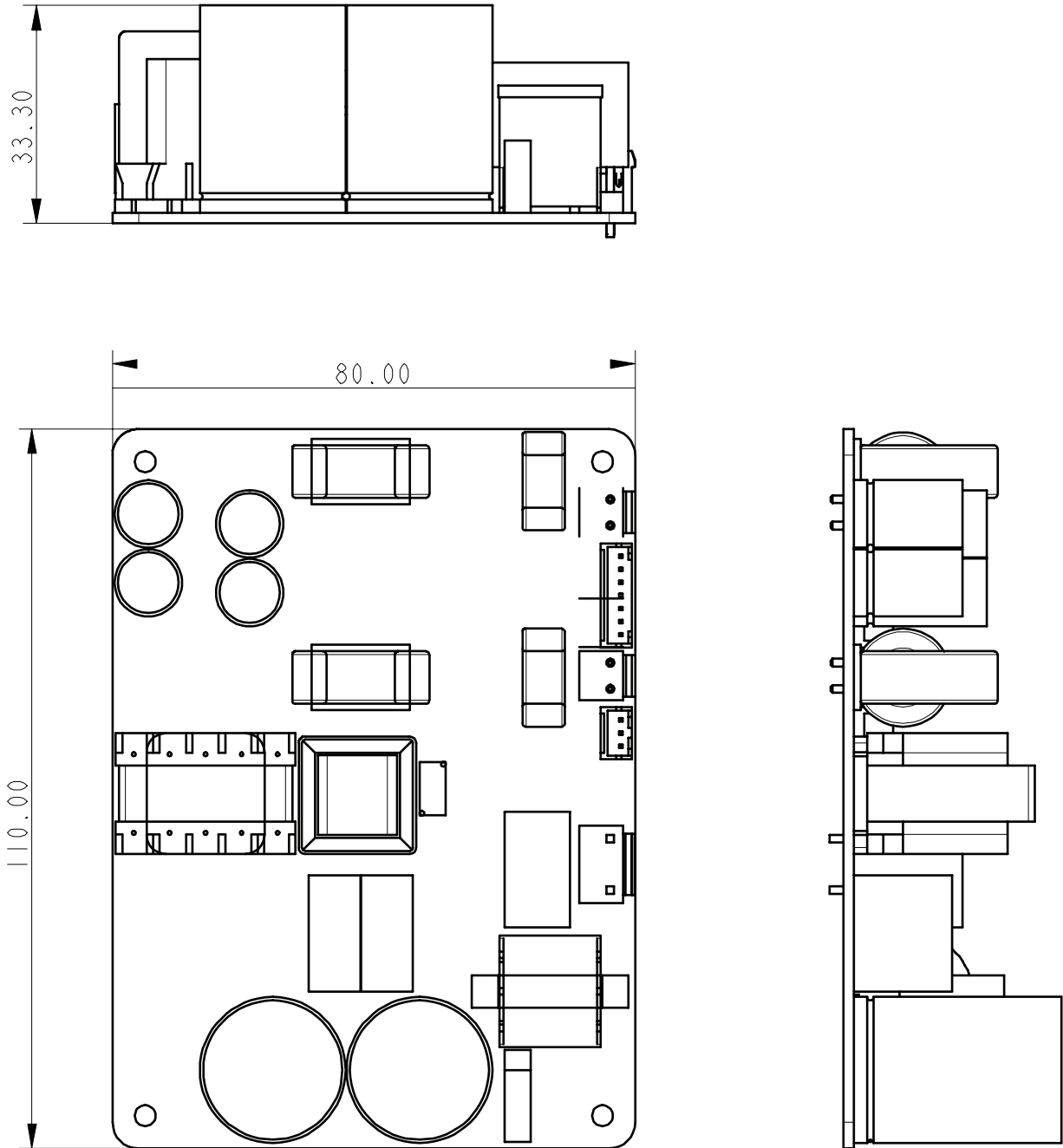

Figure 20: Physical dimensions in mm.

Important! A minimum clearance of 12 mm. around the module is required for safety and ventilation reasons.



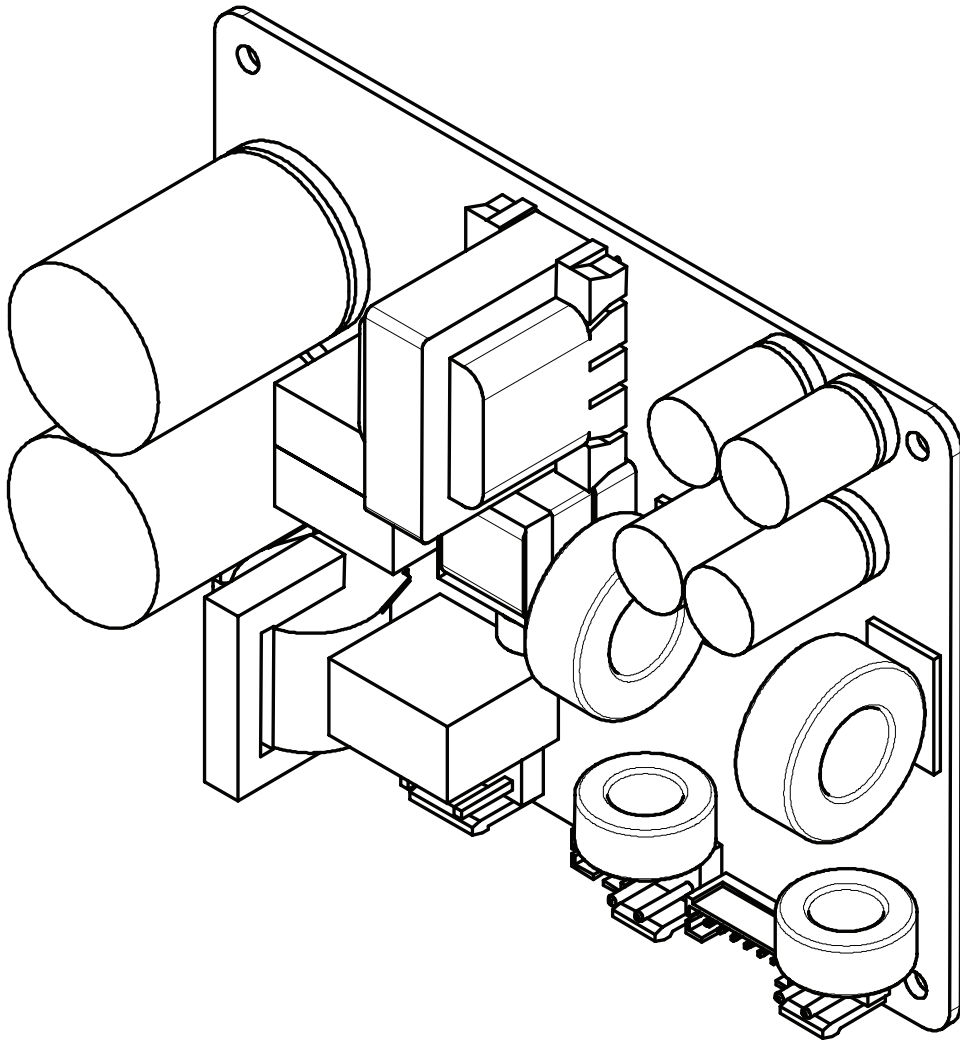

Figure 21: 3D-view of the ICEpower50ASX board.

### Drill Pattern

All dimensions are in mm. The diameter of the mounting holes is 3.5 mm.  
 Height above the PCB is 30 mm.

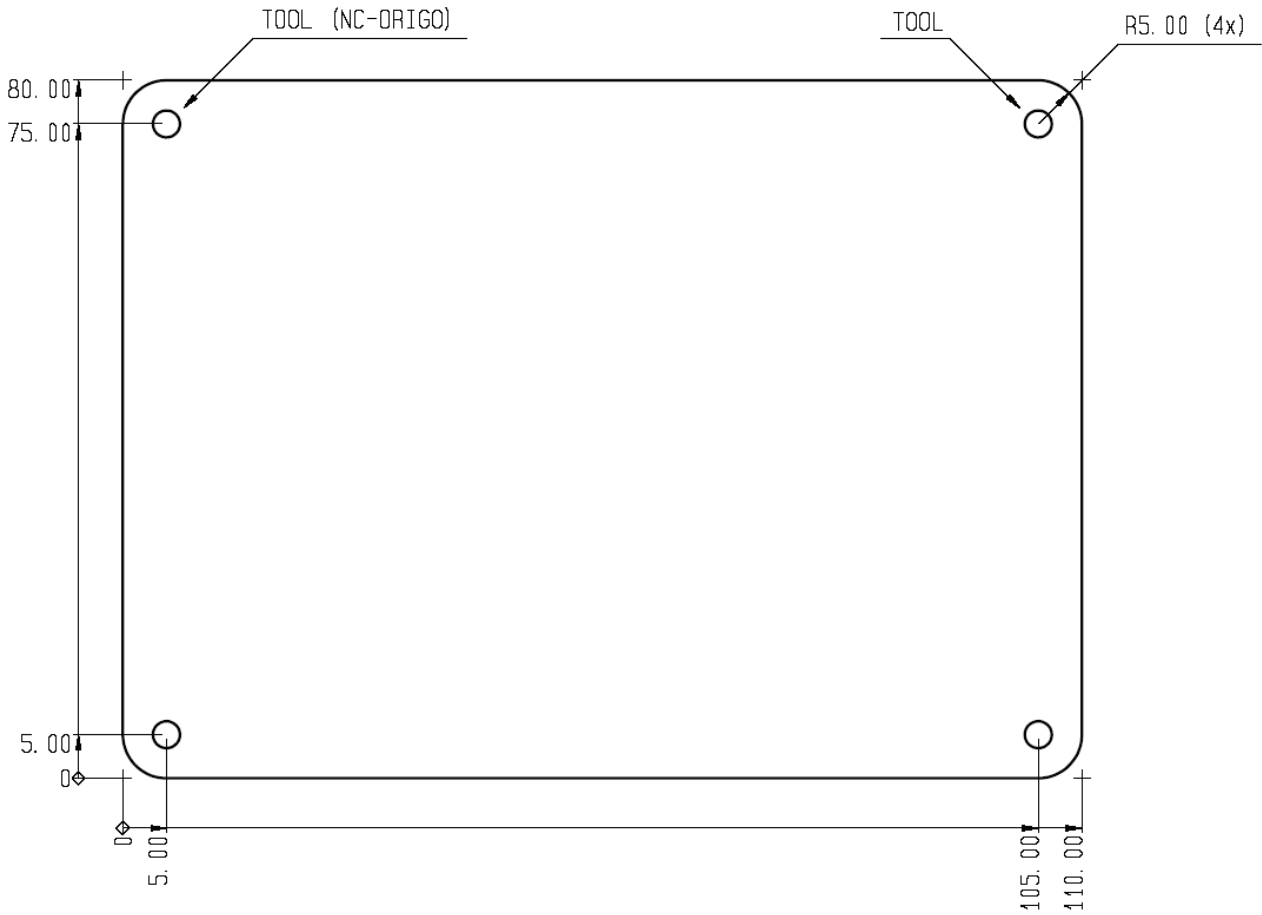

Figure 22: PCB drill pattern.

## Safety Standards

The ICEpower50ASX2 has been safety approved by UL to ease the design-in procedure and complies with the following standards:

Europe: IEC 60065 7<sup>th</sup> ed. (2001)  
 US: UL 60065 7<sup>th</sup> ed.

### Safety Class

Class 2 (without earth)

## ESD Warning

ICEpower products are manufactured according to the following ESD precautions:

- IEC 61340-5-1: Protection of electronic devices from electrostatic phenomena. General Requirements.
- IEC 61340-5-2: Protection of electronic devices from electrostatic phenomena. User Guide.
- ANSI/ESD-S20.20-1999: Protection of Electrical and Electronic Parts, Assemblies and Equipment.

Further handling of the products should comply with the same standards.

The general guarantee policy of Bang & Olufsen ICEpower a/s does not cover ESD damaged products due to improper handling.

## Packaging and Storing

### Dimensions and weight

Package	Quantity	Dimensions (w x d x h)	Gross Weight (kgs)
Carton	54	39x42x27 cm	11.6
Pallet	432	60x80x124 cm	105

ESD safe cardboard is used for wrapping.

Order codes	Description	Part number
ICEpower50ASX2(BTL)	1x170W ICEpower Amplifier with integrated ICEpower Supply	<b>8002660</b>
ICEpower50ASX2(SE)	2x50W ICEpower Amplifier with integrated ICEpower Supply	<b>8003225</b>

### Storage humidity

Do not expose the pallets to rain or humidity levels higher than 85%.

### Storage temperature

The pallets are to be stored at temperatures from 0°C to 70°C.

### Stacking

Pallets may not be stacked on top of each other.

## Notes

For additional information about the ICEpower® technology from Bang & Olufsen ICEpower a/s, visit our web site or contact us.

Bang & Olufsen ICEpower a/s  
Gl. Lundtoftevej 1b  
DK-2800 Kgs. Lyngby  
Denmark

Phone +45 45203600  
Fax +45 45203699

Website <http://www.ICEpower.bang-olufsen.com>  
E-mail [ICEpowerinfo@bang-olufsen.dk](mailto:ICEpowerinfo@bang-olufsen.dk)

## Notice

The data sheet contains specifications that may be subject to change without prior notice. ICEpower® is a trademark of Bang & Olufsen ICEpower a/s.

Bang & Olufsen ICEpower a/s products are not authorized for use as critical components in life support devices or life support systems without the express written approval of the president and general counsel of Bang & Olufsen ICEpower a/s. As used herein:

1. Life support devices or systems are devices or systems which, (a) are intended for surgical implant into the body, or (b) support or sustain life, and whose failure to perform when properly used in accordance with instructions for use provided in the labelling, can be reasonably expected to result in a significant injury to the user.
2. A critical component is any component of a life support device or system whose failure to perform can be reasonably expected to cause the failure of the life support device or system, or to affect its safety or effectiveness.