

DWG. No. DSL40-60-02

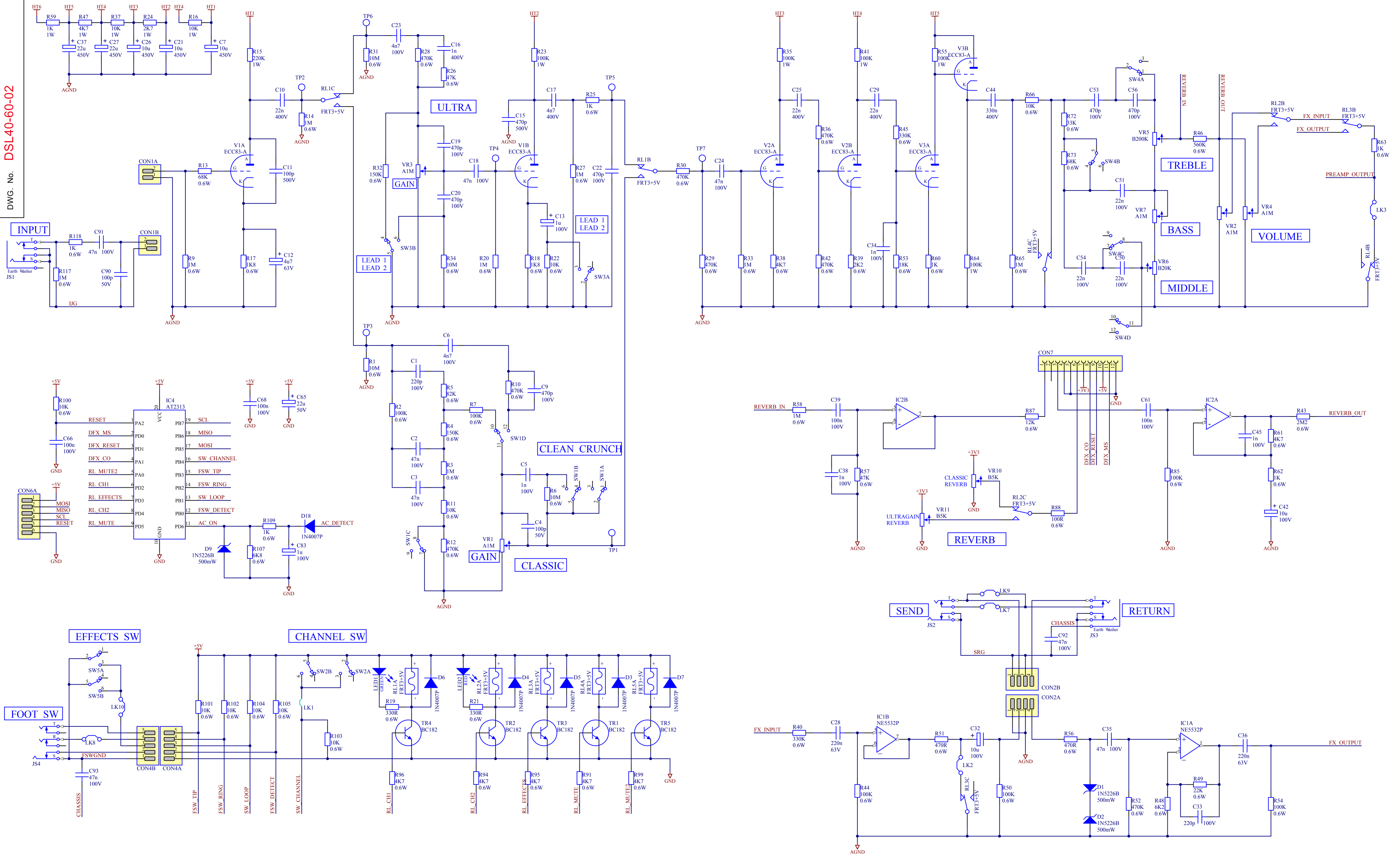

2	NO NUMBER GIVEN	16MAY12
1	Separated from 100W	12APR12
ISS	ECO NUMBER	DATE

MATERIAL	DIMENSIONS INmm
MATERIAL THICKNESS	TOLERANCE (UNLESS OTHERWISE STATED)
DRAWN J.L.	DATE 7MAR11
CHECKED	DATE
APPROVED	DATE
	MODEL DSL40C



TITLE	40W MAIN PCB
DWG. No.	DSL40-60-02
ISS	2
Sheet	1 of 2
Date: 17/05/2012	

DWG. No. DSL40-60-02

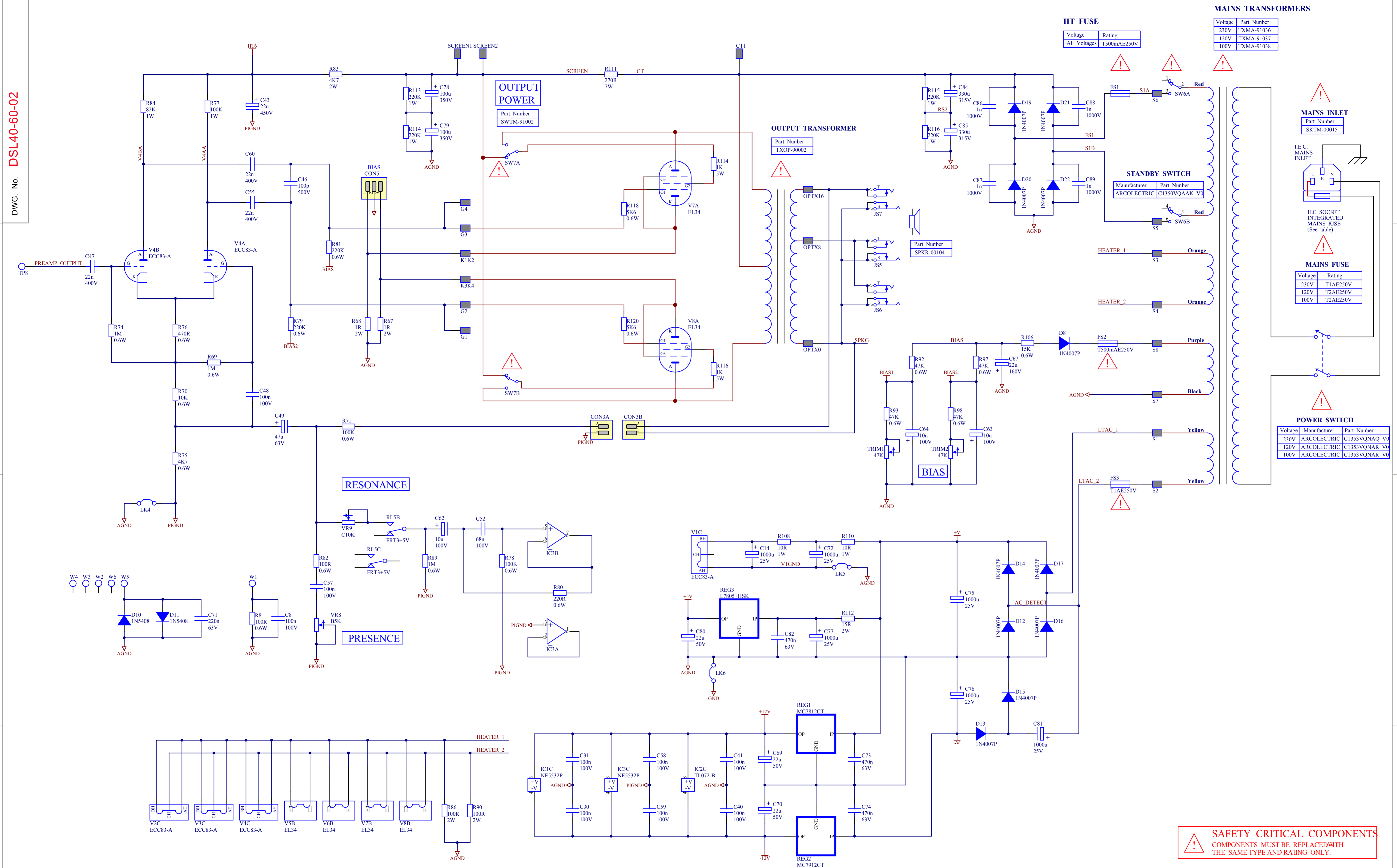

HT FUSE

Voltage	Rating
230V	T500mAE250V
120V	T500mAE250V
100V	T500mAE250V

MAINS TRANSFORMERS

Voltage	Part Number
230V	TXMA-91036
120V	TXMA-91037
100V	TXMA-91038

MAINS INLET

Part Number
SKTM-00015

MAINS FUSE

Voltage	Rating
230V	T1AE250V
120V	T2AE250V
100V	T2AE250V

POWER SWITCH

Voltage	Manufacturer	Part Number
230V	ARCOLECTRIC	C1353VQNAQ V0
120V	ARCOLECTRIC	C1353VQNAQ V0
100V	ARCOLECTRIC	C1353VQNAQ V0

SAFETY CRITICAL COMPONENTS
COMPONENTS MUST BE REPLACED WITH THE SAME TYPE AND RATING ONLY.

2	NO NUMBER GIVEN	16MAY12
1	Seperated from 100W	12APR12
ISS	ECO NUMBER	DATE

MATERIAL	DIMENSIONS INmm
MATERIAL THICKNESS	TOLERANCE (UNLESS OTHERWISE STATED)
DRAWN J.L.	DATE 7MAR11
CHECKED	DATE
APPROVED	DATE

MODEL	DSL40C
-------	--------



TITLE	40W MAIN PCB
DWG. No.	DSL40-60-02
ISS	2
Sheet	2 of 2
Date: 17/05/2012	

DSL40/100 Spares List

Title: MAIN PCB
Issue: 1



Item No	PCB Description	Value	Rating	Quantity	Designator	Marshall Stock Number	DSL100 Head Only	DSL40C only
1	MYLAR CAPACITOR	22n	100V	3	C50, C51, C54	CAPR-10079		
2	CAPACITOR CERAMIC DISC	100p	50V	1	C4	CAPR-10017		
3	CAPACITOR POLYESTER FILM	47n	100V	8	C2, C3, C18, C24, C35, C91, C92, C93	CAPR-10081		
4	MULTILAYER CAPACITOR	470p	100V	6	C9, C19, C20, C22, C53, C56	CAPR-91004		
5	BOX CAPACITOR	100n	100V	13	C8, C30, C31, C39, C40, C41, C48, C57, C58, C59, C61, C66, C68	CAPR-10185		
6	CAPACITOR ELECTRO	10u	100V	5	C32 C42, C62, C63, C64	CAPR-91009		
7	CAPACITOR CERAMIC DISC	100p	50V	1	C90	CAPR-10017		
8	CAPACITOR POLYESTER FILM	1n	100V	4	C5, C34, C38, C45	CAPR-10088		
9	CAPACITOR ELECTRO	22u	50V	4	C65, C69, C70, C80	CAPR-10063		
10	CAPACITOR METALIZED POLY	470n	83V	3	C73, C74, C82	CAPR-10087		
11	BOX CAPACITOR	2n2	400V	1	C16	CAPR-00181		
12	BOX CAPACITOR	1n	400V	1	C16	CAPR-00191		
13	MYLAR CAPACITOR	4n7	100V	2	C6, C23	CAPR-91010		
14	CAPACITOR ELECTRO	1000u	25V	6	C14, C72, C75, C76, C77, C81	CAPR-10021		
15	CAPACITOR MULTILAYER	220p	100V	2	C1, C33	CAPR-91011		
16	BOX CAPACITOR	220n	83V	3	C28, C36, C71	CAPR-10085		
17	CAPACITOR POLYESTER FILM	68n	100V	1	C52	CAPR-10082		
18	CAPACITOR ELECTRO	47u	83V	1	C49	CAPR-10064		
19	CAPACITOR METALIZED POLY	22n	400V	6	C10, C25, C29, C47, C55, C60	CAPR-00096		
20	ELECTRO CAPACITOR	4u7	83V	1	C12	CAPR-10061		
21	CAPACITOR ELECTRO	1u	100V	2	C13, C83	CAPR-10059		
22	BOX CAPACITOR	330n	400V	1	C44	CAPR-00172		
23	CAPACITOR ELECTRO	330u	315V	2	C84, C85	CAPR-91007		
24	BOX CAPACITOR	4n7	400V	1	C17	CAPR-10175		
25	CAPACITOR ELECTRO	100u	350V	2	C78, C79	CAPR-91008		
26	CAPACITOR CERAMIC DISC	470p	500V	1	C15	CAPR-10008		
27	CAPACITOR ELECTRO	10u	450V	3	C7, C21, C26	CAPR-10115		
28	CAPACITOR POLYPROPYLENE	1n	1000V	4	C86, C87, C88, C89	CAPR-91012		
29	CAPACITOR CERAMIC DISC	100p	500V	2	C11, C46	CAPR-10006		
30	CAPACITOR ELECTRO	22u	160V	1	C67	CAPR-20027		
31	CAPACITOR ELECTRO	22u	450V	3	C27, C37, C43	CAPR-00058		
32	CONNECTOR HEADER	2WAY		4	CON1A, CON1B, CON3A, CON3B	TERM-91001		
33	CONNECTOR HEADER	4WAY		2	CON2A, CON2B	TERM-91003		
34	CONNECTOR HEADER	5WAY		2	CON4A, CON4B	TERM-91004		
35	CONNECTOR HEADER	3WAY		1	CON5	TERM-00037		
36	CONNECTOR HEADER	6WAY		1	CON6	TERM-91005		
37	CONN SKT STRIP FOR MODULE STR	12WAY		1	CON7	TERM-91006		
38	CONNECTOR SPADE	1WAY		20	CT1, G1, G2, G3, G4, K1K2, K3K4, OPTX0, OPTX8, OPTX16, S1, S2, S3, S4, S5, S6, S7, S8, SCREEN1, SCREEN2	CONN-91001		
39	ZENER DIODE	1N5226B	500mW	3	D1, D2, D9	DIOD-10026		
40	DIODE	1N4007P	1A	17	D3, D4, D5, D6, D7, D8, D12, D13, D14, D15, D16, D17, D18, D19, D20, D21, D22,	DIOD-10001		
41	DIODE	1N5408	3A	2	D10, D11	DIOD-24017		
42	FUSE CLIP 20mm		5X20mm+FSC IIP-20mm	6	FS1, FS2, FS3	FUSE-10040		
43	IC CMOS MICROCONTROLLER+IC SKT	AT2313		1	IC4	ICXX-21078+SKTP-00033		
44	IC OP AMP	NE5532P		2	IC1, IC3	ICXX-00028		
45	IC JFET OP AMP	TL072-B		1	IC2	ICXX-00037		
46	JACKSOCKET MONO EW			2	JS1, JS3	SKTP-00038		
47	JACKSOCKET MONO S2			4	JS2, JS5, JS6, JS7	SKTP-00003		
48	JACKSOCKET STEREO			1	JS4	SKTP-00002		
49	LED 5mm GREEN R/ANGLE	5mm		1	LED1	LEDS-00009		
50	LED 5mm RED R/ANGLE	5mm		1	LED2	LEDS-00008		
51	LINK 0.350"	350		5	LK6, LK7, LK8, LK9, LK10	WIRE-35014		
52	LINK 0.500"	500		5	LK1, LK2, LK3, LK4, LK5	WIRE-50014		
53	METAL FILM RESISTOR	10M	0.6W	4	R1, R6, R31, R34	RESA-10401		
54	METAL FILM RESISTOR	100K	0.6W	9	R2, R7, R44, R46, R50, R54, R71, R78, R85	RESA-10196	R46 is 100K	R46 is 560K
55	METAL FILM RESISTOR	470K	0.6W	9	R10, R12, R28, R29, R30, R36, R42, R43, R52	RESA-10283	R43 is 470K	R43 is 2M2
56	METAL FILM RESISTOR	150K	0.6W	2	R4, R32	RESA-10280		
57	METAL FILM RESISTOR	68K	0.6W	2	R13, R73	RESA-10182		
58	METAL FILM RESISTOR	1K	0.6W	6	R25, R60, R62, R63, R109, R118	RESA-10250		
59	RESISTOR MFILM	1M	0.6W	12	R3, R9, R14, R20, R27, R33, R58, R65, R69, R74, R89, R117	RESA-10243		
60	METAL OXIDE RESISTOR	15R	2W	1	R112	RESA-91002		
61	METAL FILM RESISTOR	82K	0.6W	1	R5	RESA-10195		
62	RESISTOR MFILM	10K	0.6W	10	R11, R22, R66, R70, R100, R101, R102, R103, R104, R105	RESA-10048		
63	METAL FILM RESISTOR	47K	0.6W	6	R26, R57, R92, R93, R97, R98	RESA-10244		
64	RESISTOR MFILM	470R	0.6W	3	R51, R56, R76	RESA-10253		
65	RESISTOR MFILM	33K	0.6W	1	R72	RESA-10245		
66	RESISTOR MFILM	100R	0.6W	3	R8, R82, R88	RESA-10255		
67	RESISTOR MFILM	4K7	0.6W	8	R38, R61, R75, R91, R94, R95, R96, R99	RESA-10247		
68	RESISTOR MFILM	330R	0.6W	2	R19, R21	RESA-10258		
69	METAL FILM RESISTOR	22K	0.6W	1	R49	RESA-10193		
70	METAL FILM RESISTOR	220R	0.6W	1	R80	RESA-10254		
71	METAL FILM RESISTOR	12K	0.6W	1	R87	RESA-10179		
72	RESISTOR MFILM	1K8	0.6W	2	R17, R18	RESA-10281		
73	METAL FILM RESISTOR	2K2	0.6W	1	R39	RESA-10177		
74	METAL FILM RESISTOR	6K2	0.6W	1	R48	RESA-91010		
75	METAL OXIDE RESISTOR	10R	1W	2	R108, R110	RESA-10127		
76	METAL FILM RESISTOR	330K	0.6W	2	R40, R45	RESA-10259		
77	RESISTOR MFILM	18K	0.6W	1	R53	RESA-10282		
78	METAL OXIDE RESISTOR	220K	1W	5	R15, R113, R114, R115, R116	RESA-91003		
79	METAL OXIDE RESISTOR	100K	1W	6	R23, R35, R41, R55, R64, R77	RESA-91004		
80	METAL OXIDE RESISTOR	82K	1W	1	R84	RESA-91005		
81	METAL OXIDE RESISTOR	100R	2W	2	R86, R90	RESA-10171		
82	METAL OXIDE RESISTOR	10K	1W	2	R16, R37	RESA-10079		
83	METAL OXIDE RESISTOR	2K7	1W	1	R24	RESA-91006		
84	METAL OXIDE RESISTOR	4K7	1W	1	R47	RESA-91007		
85	METAL OXIDE RESISTOR	1K	1W	1	R59	RESA-91008		
86	METAL OXIDE RESISTOR	4K7	2W	1	R83	RESA-91009		
87	RESISTOR MOXIDE	1R	2W	2	R67, R68	RESA-10373		
88	METAL FILM RESISTOR	220K	0.6W	2	R79, R81	RESA-10164		
89	METAL FILM RESISTOR	15K	0.6W	1	R106	RESA-10276		
90	CEMENT RESISTOR	270R	7W	1	R111	RESR-00024		
91	METAL FILM RESISTOR	6K8	0.6W	1	R107	RESA-10246		
92	VOLTAGE REGULATOR + HEATSINK	L7805+HSK	+5V	1	REG3	VREG-20005+HSNK-91003		
93	VOLTAGE REGULATOR	MC7912CT	-12V	1	REG2	VREG-00001		
94	VOLTAGE REGULATOR	MC7812CT	+12V	1	REG1	VREG-00002		
95	RELAY	FRT3+5V	5V	5	RL1, RL2, RL3, RL4, RL5	RLAY-91002		
96	SWITCH LATCH R/A	12PIN 4PDT	30V	2	SW1, SW4	SWTP-00051		
97	SWITCH LATCH R/A	6PIN DPDT	30V	3	SW2, SW3, SW5	SWTP-00050		
98	TRANSISTOR	BC182		5	TR1, TR2, TR3, TR4, TR5	TRAN-10005		
99	TRIMMER TOP ADJ	47K	0.15W	2	TRIM1, TRIM2	TRIM-91001		
100	VALVE BASE	ECC83-A	ECC83	4	V1, V2, V3, V4	VLVE-00076		
101	HORIZ POT H=10mm	A1M		5	VR1, VR2, VR3, VR4, VR7	POTP-00059		
102	HORIZ POT H=10mm	B20K		1	VR5	POTP-00058		
103	HORIZ POT H=10mm	B20K		1	VR6	POTP-00056		
104	HORIZ POT H=10mm	B5K		3	VR8, VR10, VR11	POTP-00063		
105	POT 11MM HORIZ	C10K		1	VR9	POTP-91006		
106	EFFECTS PCB			1	Reverb	DFXX-91001		
	SPACER FOR EFFECTS PCB height 12.7mm			2		SPCR-00013		