

Fulltone "69" Pedal

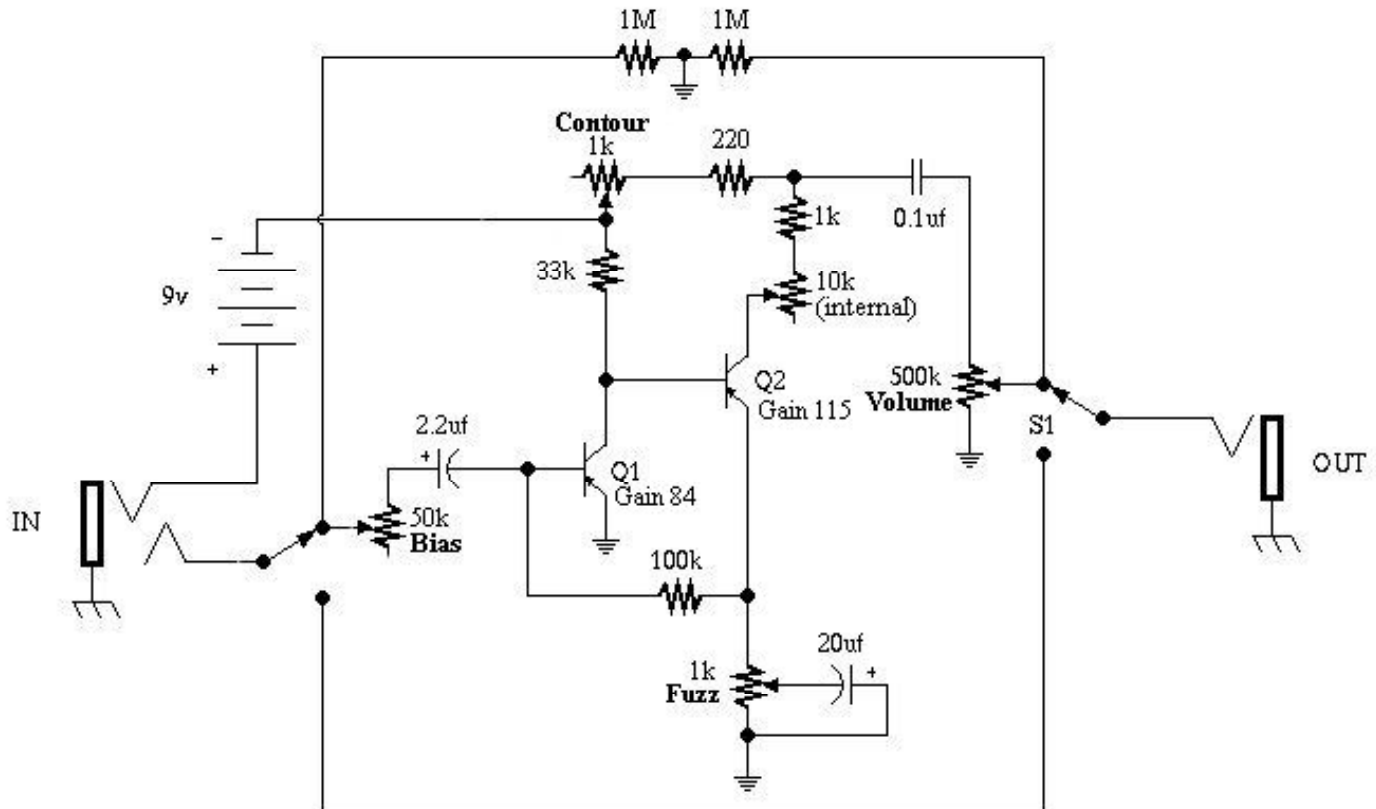

Volume: controls the output level of the device when pedal is on.

Bias: controls input impedance...full clockwise rotation gets stock fuzzface sounds
Lowering this knob lets the pedal work better with wah wahs better and removes the "woofiness" or bass that can sometimes muddy-up a fuzzface-type circuit.

Contour: Adds midrange clarity and overall gain when turned clockwise.

Fuzz: Controls the amount of distortion/fuzz.