

The HF Resistor Application Guide

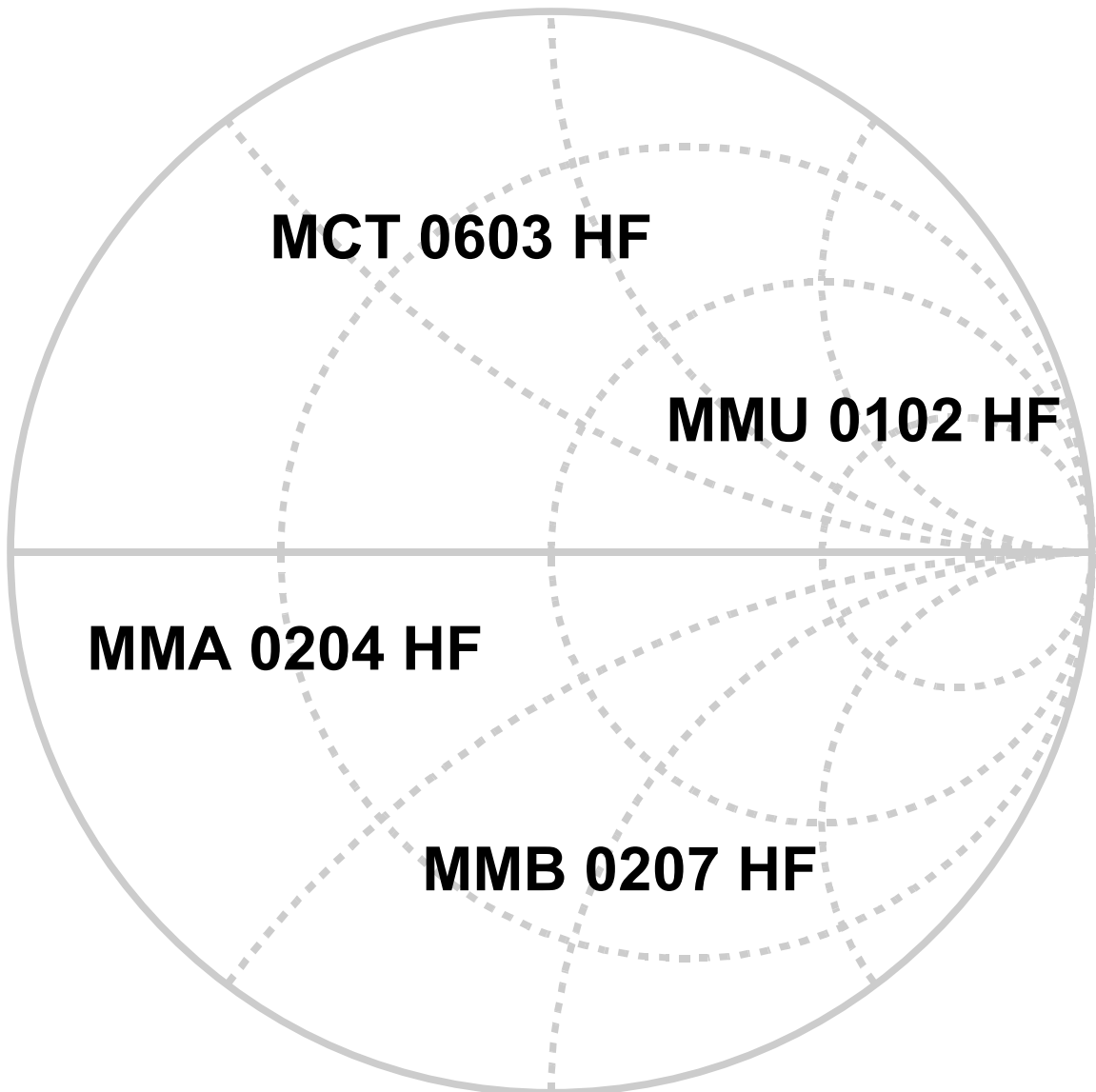

including data sheets of

HF Resistors

made by

BEYSCHLAG

Contents

1. Resistor Models	2
<i>Resistor Substitution Circuit</i>	3
<i>Quantification of Parasitic Elements</i>	3
2. Z /R Plots	4
<i>How to Read the Z /R Plots</i>	5
<i>Comparing 50 Ω Resistors</i>	5
<i>HF Resistors</i>	6
<i>Standard Resistors</i>	8
3. Formulae & Figures	11
<i>Cross Reference Tables</i>	12
<i>Return Loss vs. Standing Wave Ratio</i>	13
<i>Impedance of Capacitors and Inductors</i>	13
<i>Equations</i>	14
4. Standard HF Applications	15
<i>Power Divider</i>	16
<i>Wilkinson Divider</i>	16
<i>T-Attenuator</i>	16
<i>Π-Attenuator</i>	16
<i>10 dB-Attenuator using MCT 0603</i>	17
<i>Low Cost Terminations vs. Optimized 50 Ω Termination using MICRO-MELF MMU 0102 HF</i>	18
5. Data Sheets	20
<i>Product Selection Guide and Resistance Range</i>	21
<i>MCT 0603 HF</i>	22
<i>MMU 0102 HF, MMA 0204 HF, MMB 0207 HF</i>	26
6. Engineering Support & Design in	32

1. Resistor Models

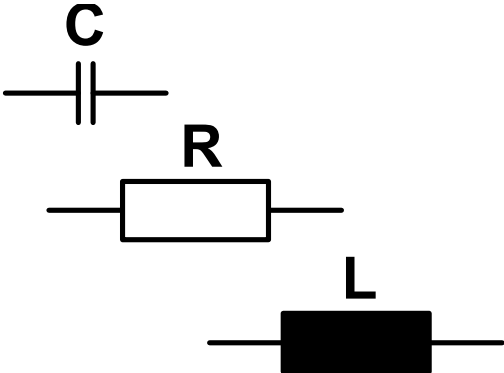

Resistor Substitution Circuit

Theoretically a resistor is frequency-independent. Actually there is an additional contribution of the impedance originated by an inductance L and a capacitance C . The inductance results from the trimming geometry, the capacitance is formed by the ceramic dielectric of the resistor body and the metallic terminations.

The substitution circuit below is used to describe the resistor's behaviour. The capacitors C_i are formed by integrating the resistor into the circuit.

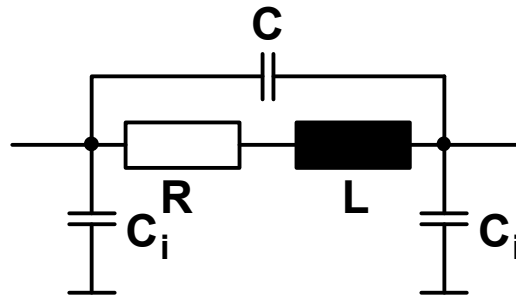

Quantification of Parasitic Elements

Below some typical values are given for MCT 0603 (HF) flat chip resistors as well as for standard MELF resistors. They are valid for impedance-to-resistance-ratios ($|Z|/R$) from 0,5 to 2,0.

Flat Chip Resistors MCT 0603 and MCT 0603 HF (valid thru 10 GHz)

R / Ω	MCT 0603		MCT 0603 HF	
	L / nH	C / pF	L / nH	C / pF
5,6	0,75	0,035	0,60	0,03
10	0,85	0,035		
15	0,78	0,035	0,55	0,03
39	0,80	0,035	0,55	0,03
50	0,85	0,035	0,67	0,03

Standard MELF Resistors (valid thru 3 GHz)

R / Ω	MMU 0102		MMA 0204		MMB 0207	
	L / nH	C / pF	L / nH	C / pF	L / nH	C / pF
6,8	2,1	0,15	3	-	4,5	-
27	1,9	0,15	4,2	-	7,5	0,32
50	2,3	0,15	7,6	-	10,5	0,32
100	2,5	0,15	10,5	0,08	17	0,32
150	2	0,15	12,5	0,08	20,5	0,32
220	3,1	0,15	14	0,08	22	0,32
330	5	0,15	12	0,08	22	0,32
470	-	0,15	-	0,08	24	0,32

For $|Z|/R$ vs. frequency diagrams please refer to chapter “ $|Z|/R$ Plots”.

2. $|Z|/R$ -Plots

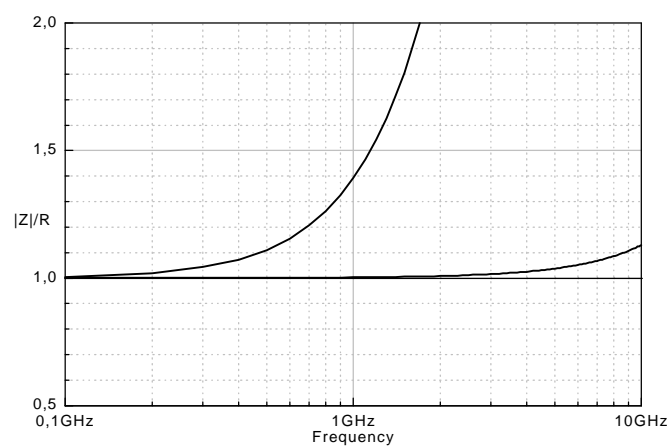

How to Read the $|Z|/R$ -Plots?

In opposition to the most often used SWR or plots of Return Loss the impedance-to-resistance plots are chosen for the following reasons:

The curves show, whether the behaviour is more inductive (increasing impedance values) or more capacitive (decreasing impedance values). Furthermore, resonance points are indicated by the change from the increasing to the decreasing part of the curves and vice versa.

The normalization of the impedance to the original resistance allows to plot the curves for different resistance values without a loss of resolution. The comparison of the parasitic elements of different resistance values of the same style becomes easier as well as the comparison of the same resistance values for different styles.

Comparing 50 Ω Resistors

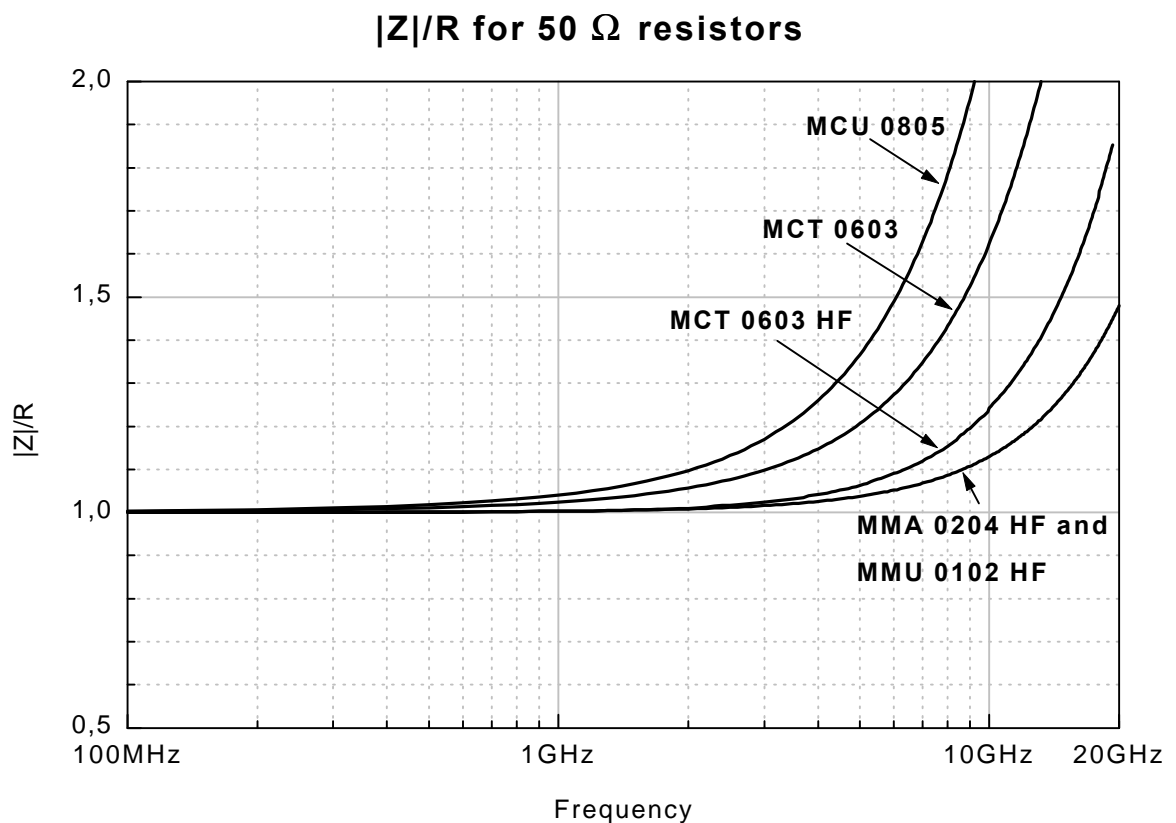

HF Resistors

MCT 0603 HF

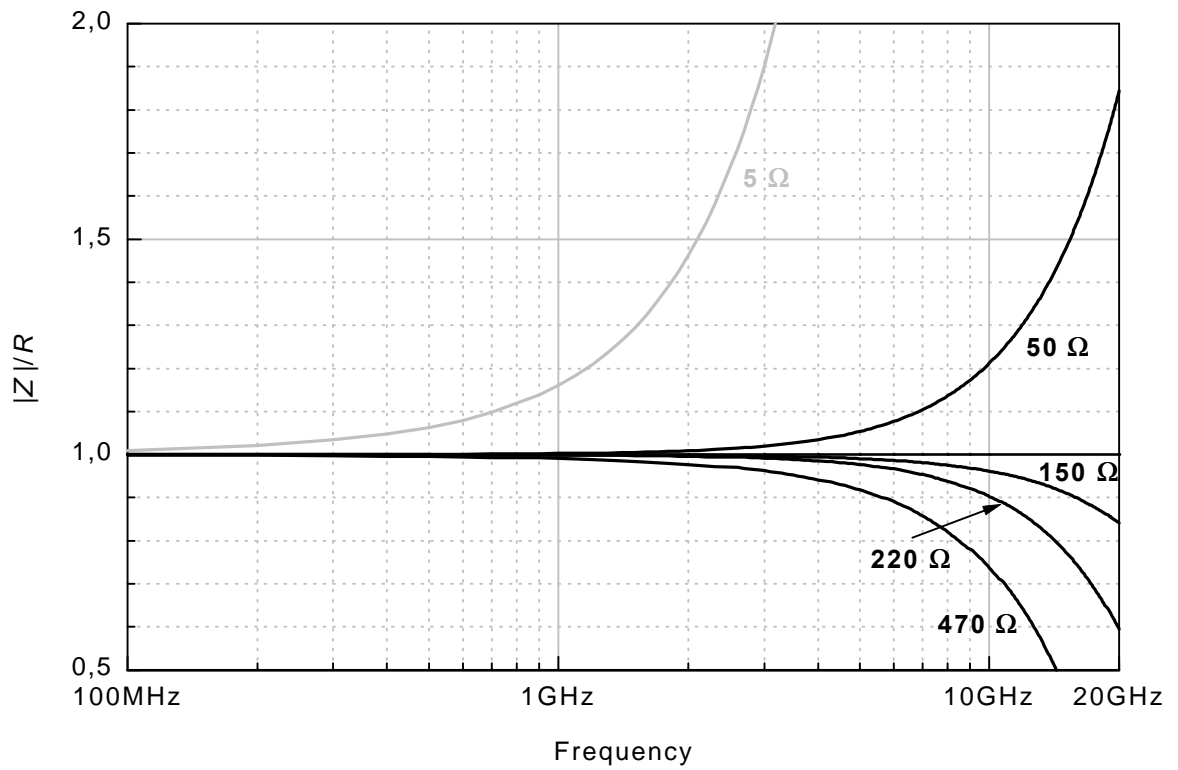

MMU 0102 HF

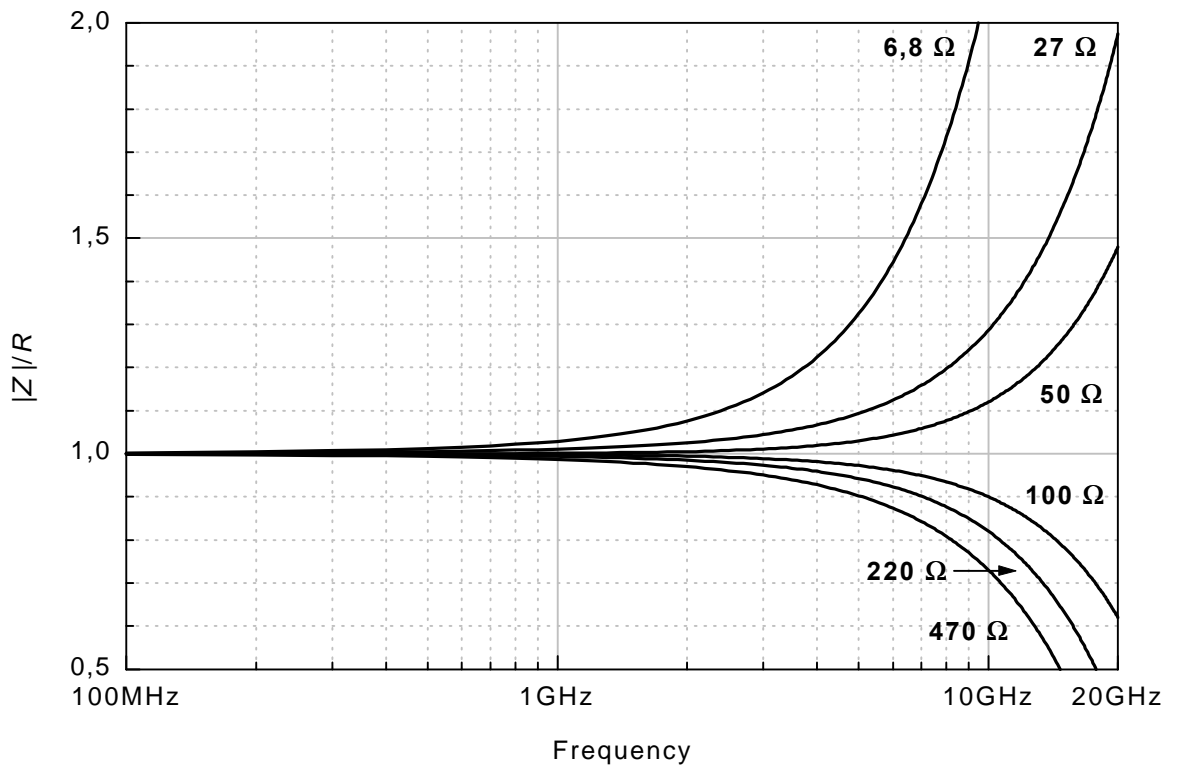

MMA 0204 HF

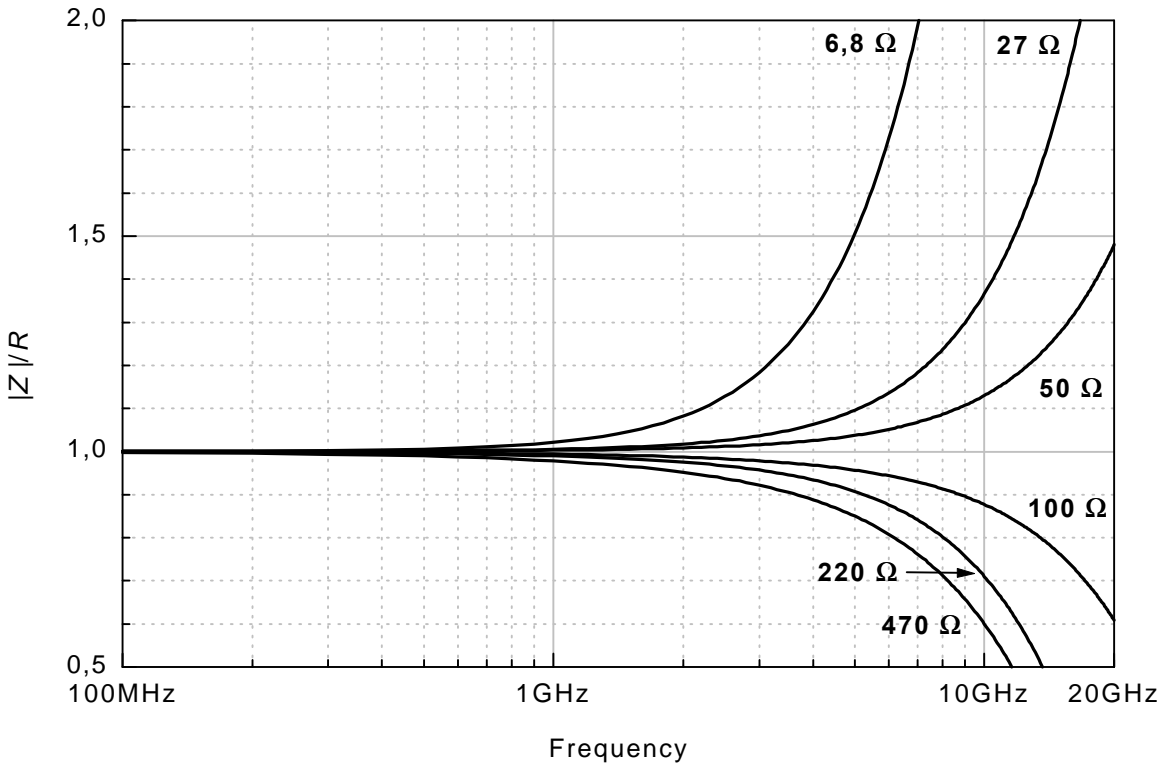

MMB 0207 HF

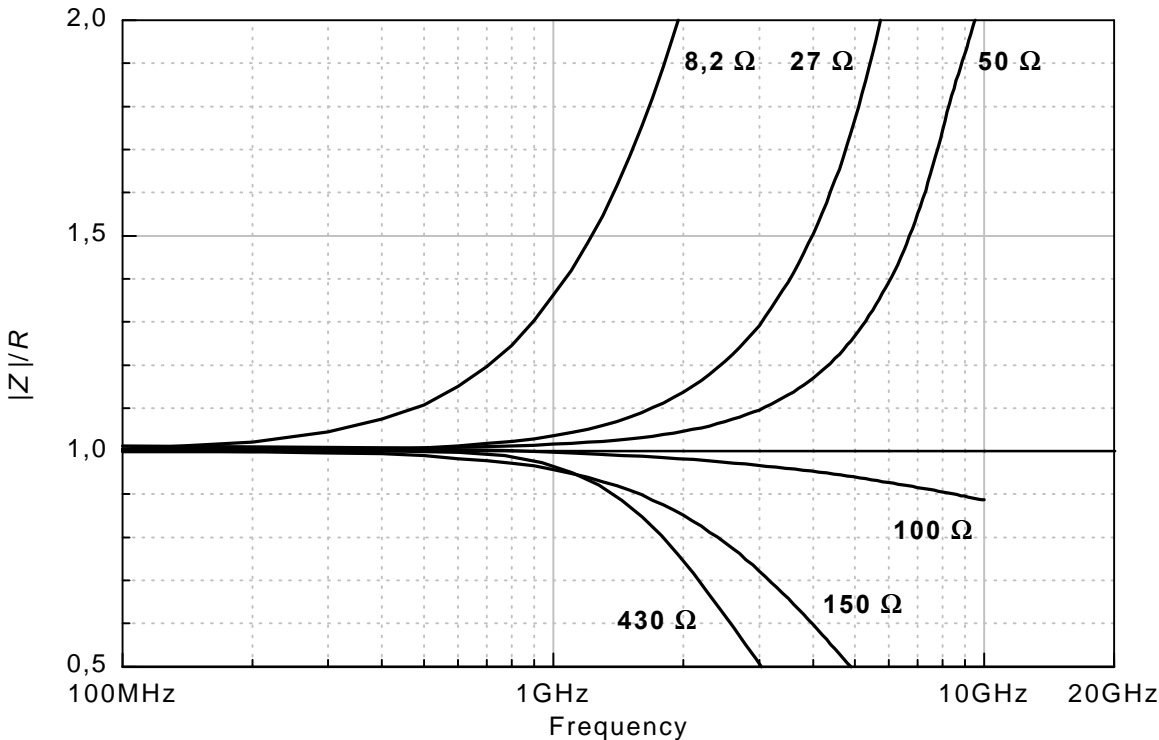

Standard Resistors

MCT 0603

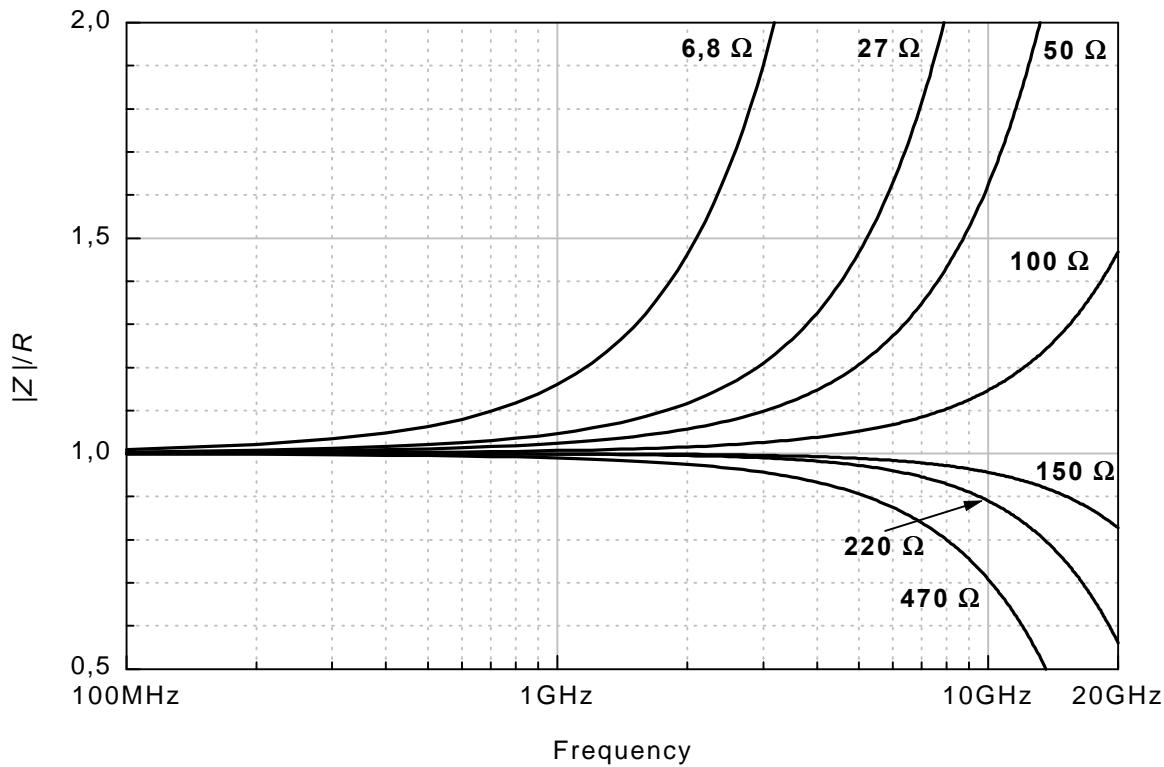

MCU 0805

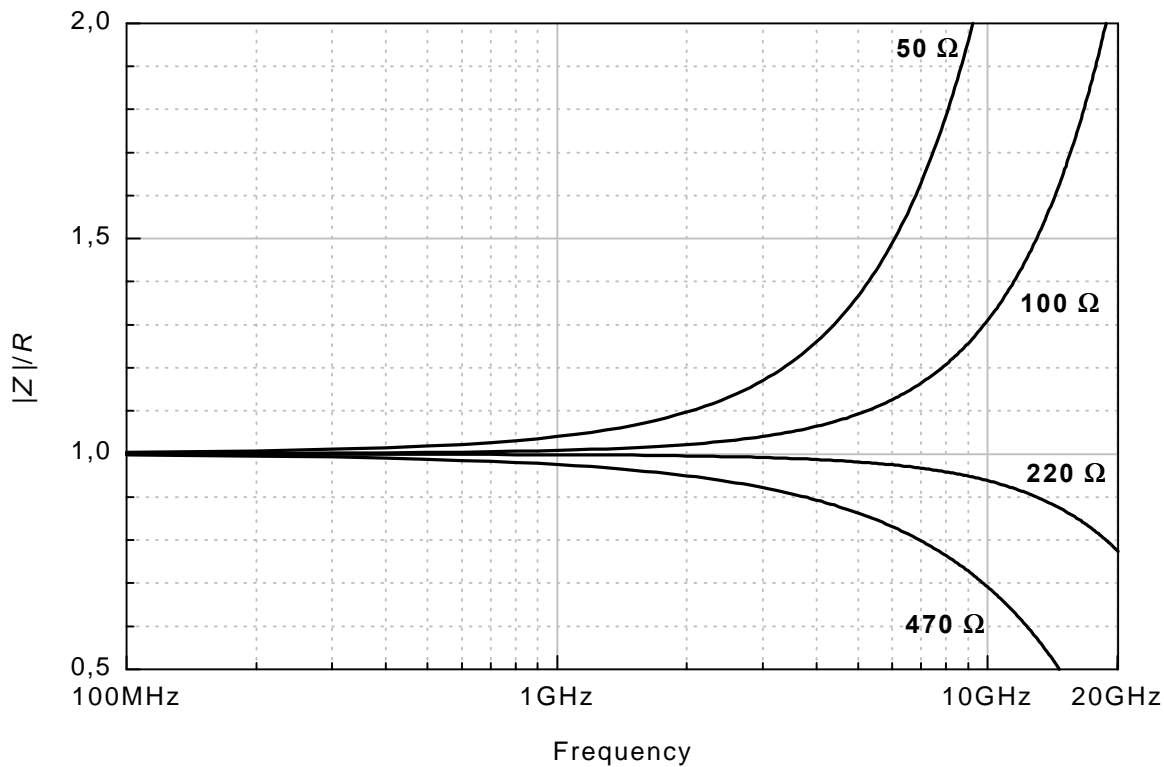

MMU 0102

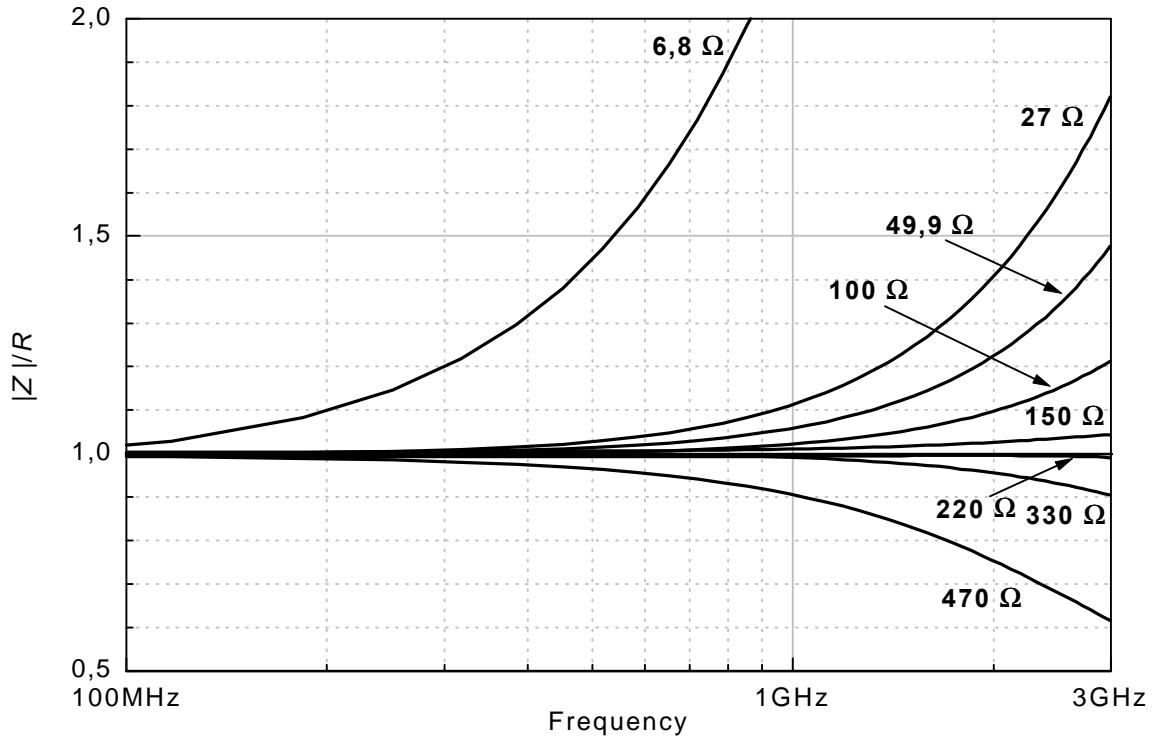

MMA 0204

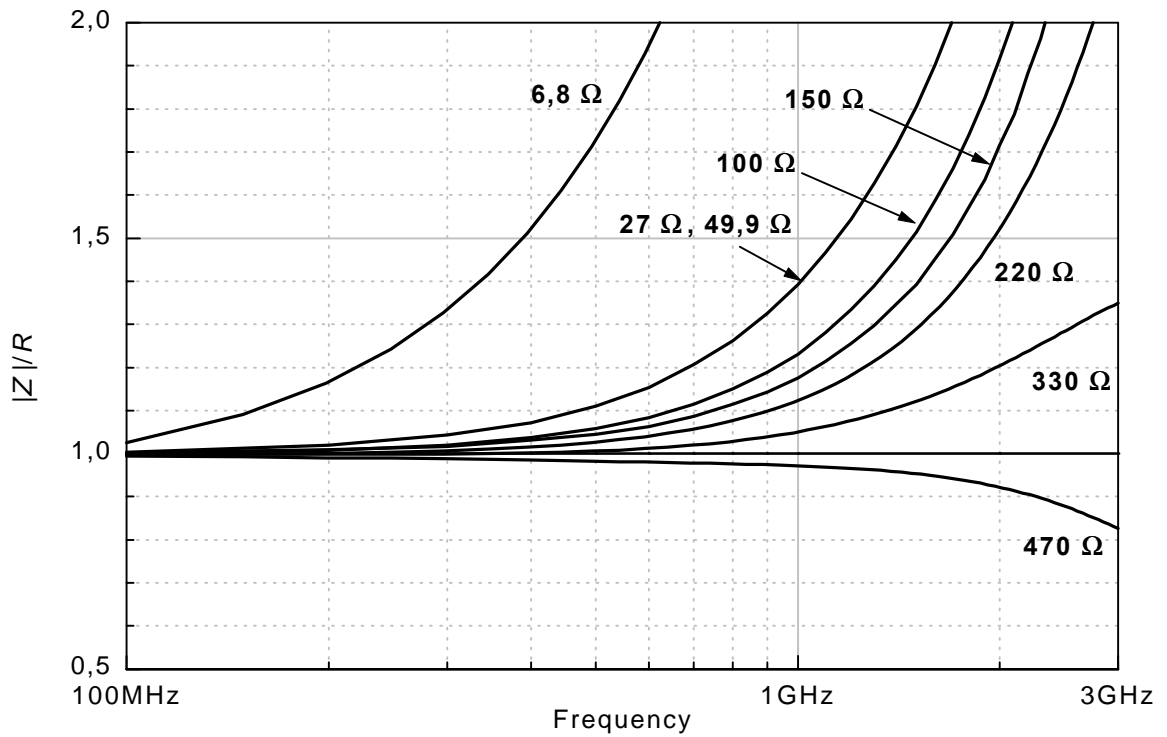

MMB 0207

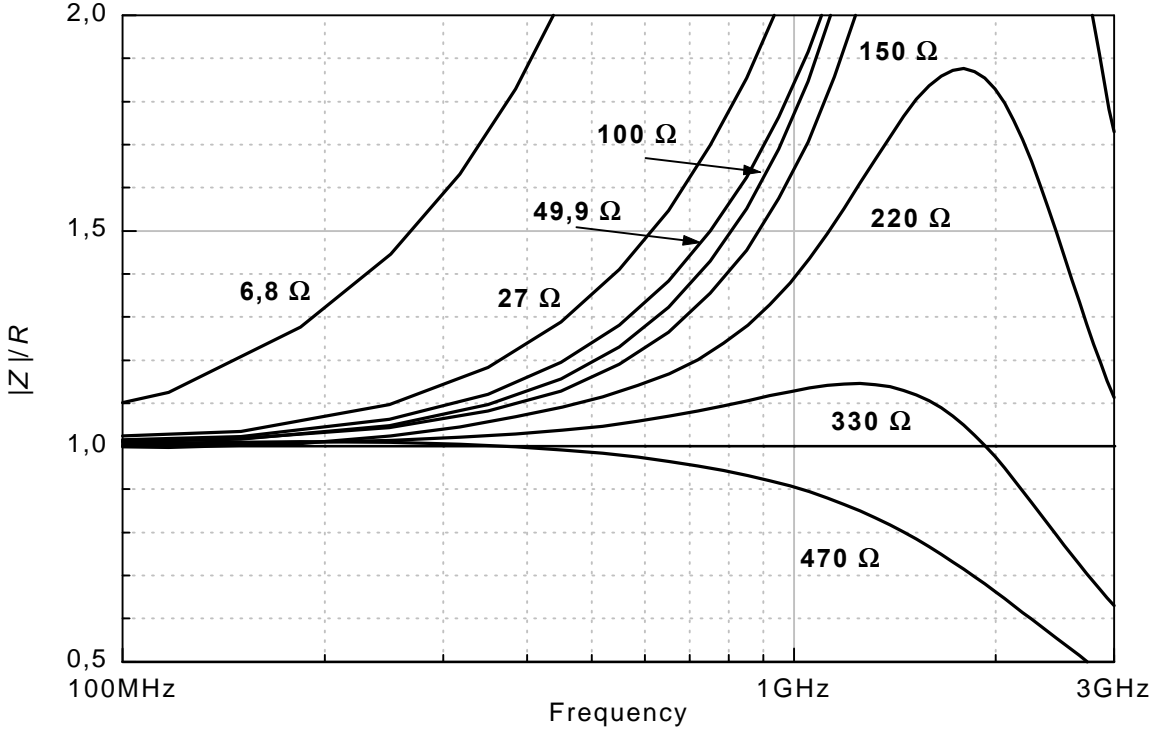

3. *Formulae & Figures*

$$r = \frac{Z - Z_0}{Z + Z_0}$$

Cross Reference Tables

a / dB	r	SWR	Z / Ω	Z / Ω
0	1,00	∞	∞	0,00
-1	0,89	17,39	869,55	2,88
-2	0,79	8,72	436,21	5,73
-3	0,71	5,85	292,40	8,55
-4	0,63	4,42	220,97	11,31
-5	0,56	3,57	178,49	14,01
-6	0,50	3,01	150,48	16,61
-7	0,45	2,61	130,73	19,12
-8	0,40	2,32	116,14	21,53
-9	0,35	2,10	104,99	23,81
-10	0,32	1,92	96,25	25,97
-15	0,18	1,43	71,63	34,90
-20	0,10	1,22	61,11	40,91
-30	0,03	1,07	53,27	46,93
-40	0,01	1,02	51,01	49,01
-50	0,00	1,01	50,32	49,68
-60	0,00	1,00	50,10	49,90

Z / Ω	r	a / dB	SWR
10	-0,67	-3,52	5,00
12	-0,61	-4,25	4,17
15	-0,54	-5,38	3,33
27	-0,30	-10,50	1,85
33	-0,20	-13,77	1,52
39	-0,12	-18,16	1,28
47	-0,03	-30,19	1,06
49,9	0,00	-59,99	1,00
50	0,00	-∞	1,00
51	0,01	-40,09	1,02
56	0,06	-24,94	1,12
68	0,15	-16,33	1,36
82	0,24	-12,31	1,64
91	0,29	-10,73	1,82
100	0,33	-9,54	2,00
150	0,50	-6,02	3,00
200	0,60	-4,44	4,00
220	0,63	-4,02	4,40
240	0,66	-3,67	4,80
270	0,69	-3,25	5,40

SWR	r	a / dB	Z / Ω	Z / Ω
1,0	0,00	-∞	50	50,0
1,1	0,05	-26,44	55	45,5
1,2	0,09	-20,83	60	41,7
1,3	0,13	-17,69	65	38,5
1,5	0,20	-13,98	75	33,3
1,6	0,23	-12,74	80	31,3
1,7	0,26	-11,73	85	29,4
1,8	0,29	-10,88	90	27,8
1,9	0,31	-10,16	95	26,3
2	0,33	-9,54	100	25,0
3	0,50	-6,02	150	16,7
4	0,60	-4,44	200	12,5
5	0,67	-3,52	250	10,0
10	0,82	-1,74	500	5,0

Z	r	Explanation
0	-1	short
Z ₀	0	matching load
∞	1	open

SWR	P _{refl} / %	Explanation
1	0	matching load
1,07	0,1	
1,22	1	
1,92	10	
∞	100	total reflection (open or short)

Return Loss a vs. Standing Wave Ratio

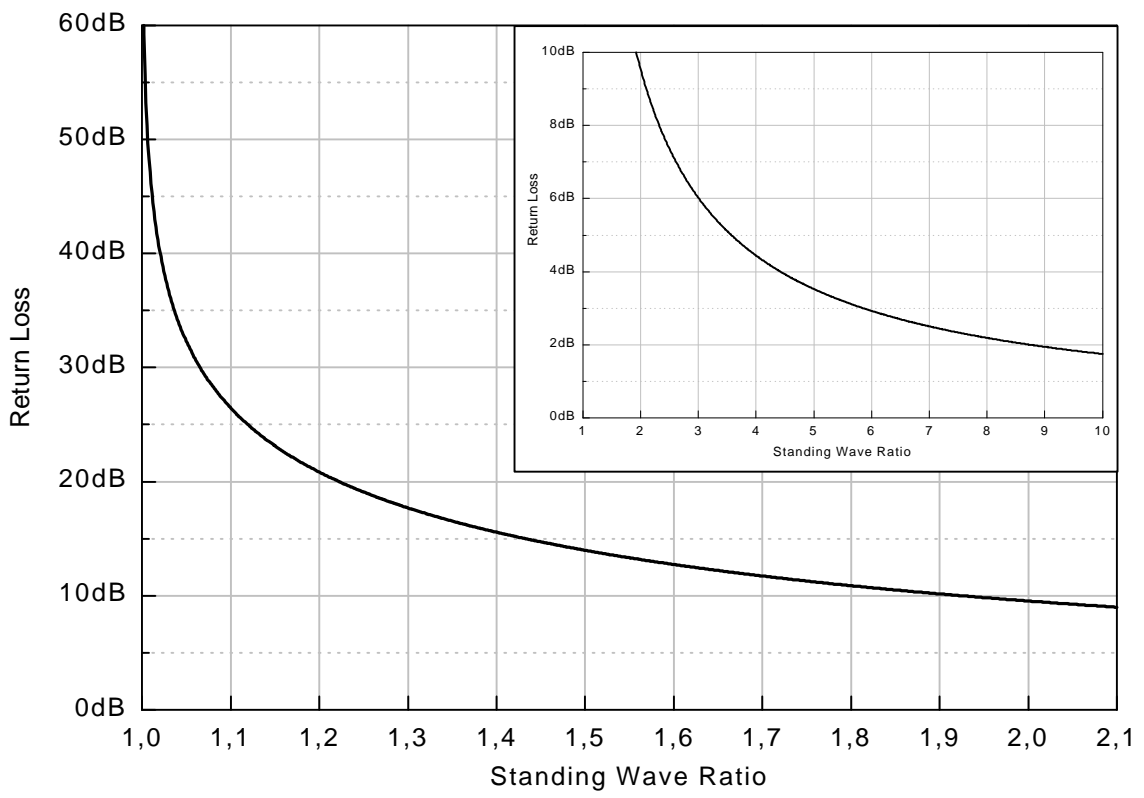

Impedance of Capacitors and Inductors

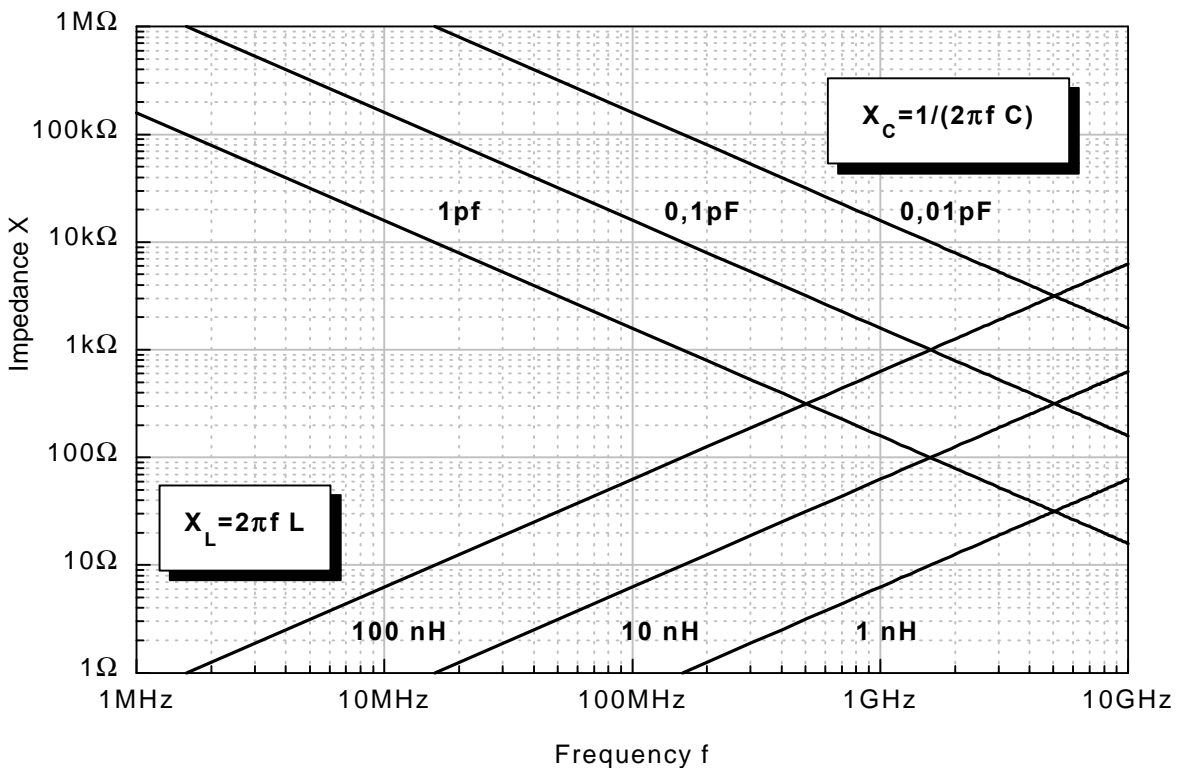

Equations

Standing Wave Ratio SWR vs. Reflection Coefficient r

$$SWR = \frac{1+|r|}{1-|r|}$$

$$|r| = \frac{SWR - 1}{SWR + 1}$$

Standing Wave Ratio SWR vs. Reflected Power P_{refl}

$$SWR = \frac{\sqrt{P_{\text{inc}}} + \sqrt{P_{\text{refl}}}}{\sqrt{P_{\text{inc}}} - \sqrt{P_{\text{refl}}}}$$

$$P_{\text{refl}} = \left(\frac{SWR - 1}{SWR + 1} \right)^2 \cdot 100 \%$$

Reflection Coefficient r vs. Impedance Z

$$r = \frac{Z - Z_0}{Z + Z_0}$$

$$Z = Z_0 \frac{1+r}{1-r}$$

Return Loss $R.L.$ vs. Magnitude of Reflection Coefficient $|r|$

$$R.L. = 20 \lg |r|$$

$$|r| = 10^{\frac{R.L.}{20}}$$

4. Standard HF-Applications

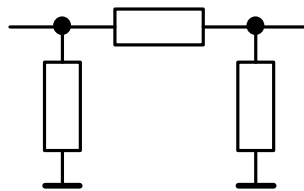

Power Divider

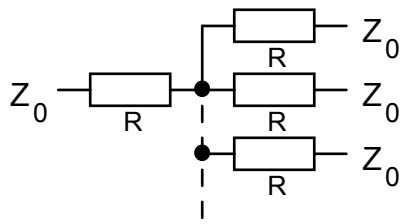

$$R = Z_0 \frac{i-1}{i+1}$$

$$a = 20 \lg \left(\frac{1}{i} \right)$$

i	R (E96) / Ω	R (E24) / Ω
2	16,5	16
3	24,9	24
4	30,1	30

i: number of outputs
values valid for $Z_0 = 50 \Omega$

Wilkinson Divider

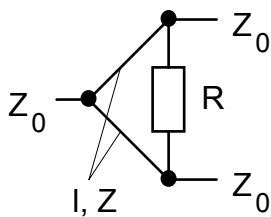

$$R = 2Z_0$$

$$l = \lambda/4 \quad Z = Z_0 \sqrt{2}$$

T-Attenuator

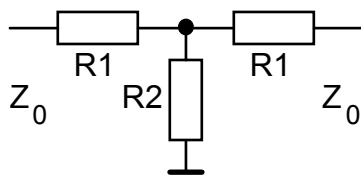

$$R_1 = Z_0 \frac{a-1}{a+1}$$

$$R_2 = Z_0 \frac{2a}{a^2-1}$$

a / dB	R1 (E96) / Ω	R2 (E96) / Ω	R1 (E24) / Ω	R2 (E24) / Ω
1	2,87	432	3	430
2	5,76	215	5,6	220
3	8,45	143	8,2	150
5	14	82,5	15	82
6	16,5	66,5	16	68
10	26,1	34,8	27	36
20	41,2	10	39	10
30	46,4	3,16	47	3

values valid for $Z_0 = 50 \Omega$

Π-Attenuator

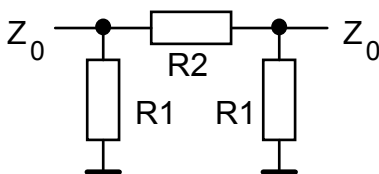

$$R_1 = Z_0 \frac{a+1}{a-1}$$

$$R_2 = Z_0 \frac{a^2-1}{2a}$$

a / dB	R1 (E96) / Ω	R2 (E96) / Ω	R1 (E24) / Ω	R2 (E24) / Ω
1	866	5,76	910	5,6
2	432	11,5	430	12
3	294	17,8	300	18
5	178	30,1	180	30
6	150	37,4	150	36
10	95,3	71,5	100	68
20	60,4	249	62	240
30	53,6	787	51	820

values valid for $Z_0 = 50 \Omega$

Note: Given resistance values are the closest E-series values to the calculated values.

10 dB Attenuator using MCT 0603

The following application is used to show the high frequency performance of metal film flat chip resistors MCT 0603.

The transmission curve is very flat up to 10 GHz and higher, the return loss is better than -20 dB up to 7 GHz.

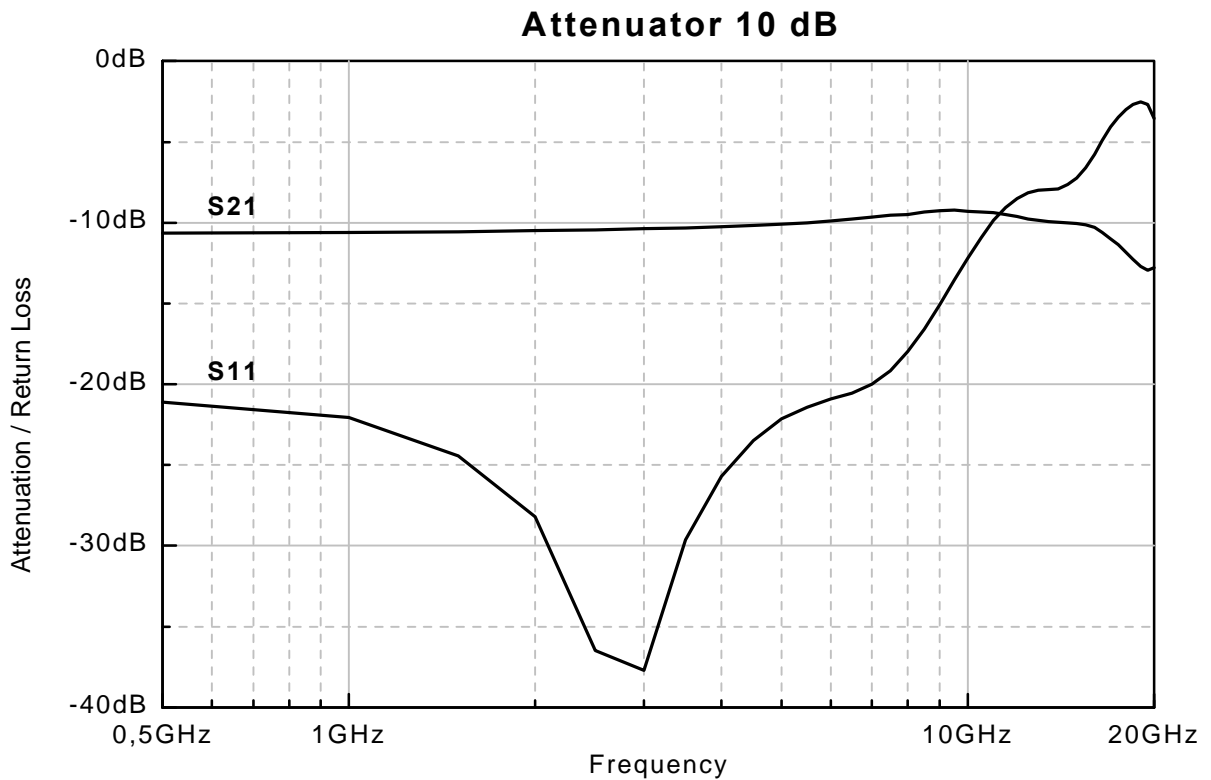
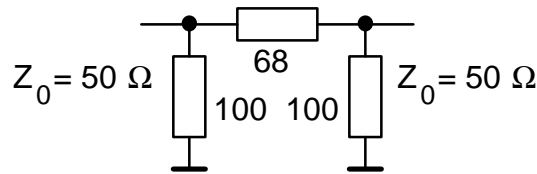

Courtesy: Ruhr Universität Bochum, Germany

Some simulation examples of attenuators are given in chapter “Simulation Examples”, example “Simulate Attenuators”.

Low Cost Terminations vs. Optimized 50 Ω Termination using MICRO-MELF MMU 0102 HF

The following graphs show the difference between low cost terminations (curve N, BNC) vs. a 50 Ω termination using two HF resistors MMU 0102 HF in parallel.

Knowing the resistor substitution circuit as given in chapter “Resistor Models” leads to a termination with better high frequency performance than with a single 50 Ω or 75 Ω resistor.

All resistors with an inductive behaviour, i.e. with an increasing impedance over the frequency range, are typically used in parallel to minimize parasitic inductance.

The Attenuation graph indicates a very good return loss for the MMU 0102 HF termination up to 10 GHz. In comparison the other terminations are not suitable for frequencies higher than 600 MHz. Additionally, the $|Z|/R$ -plot shows three points of resonance within the considered frequency range.

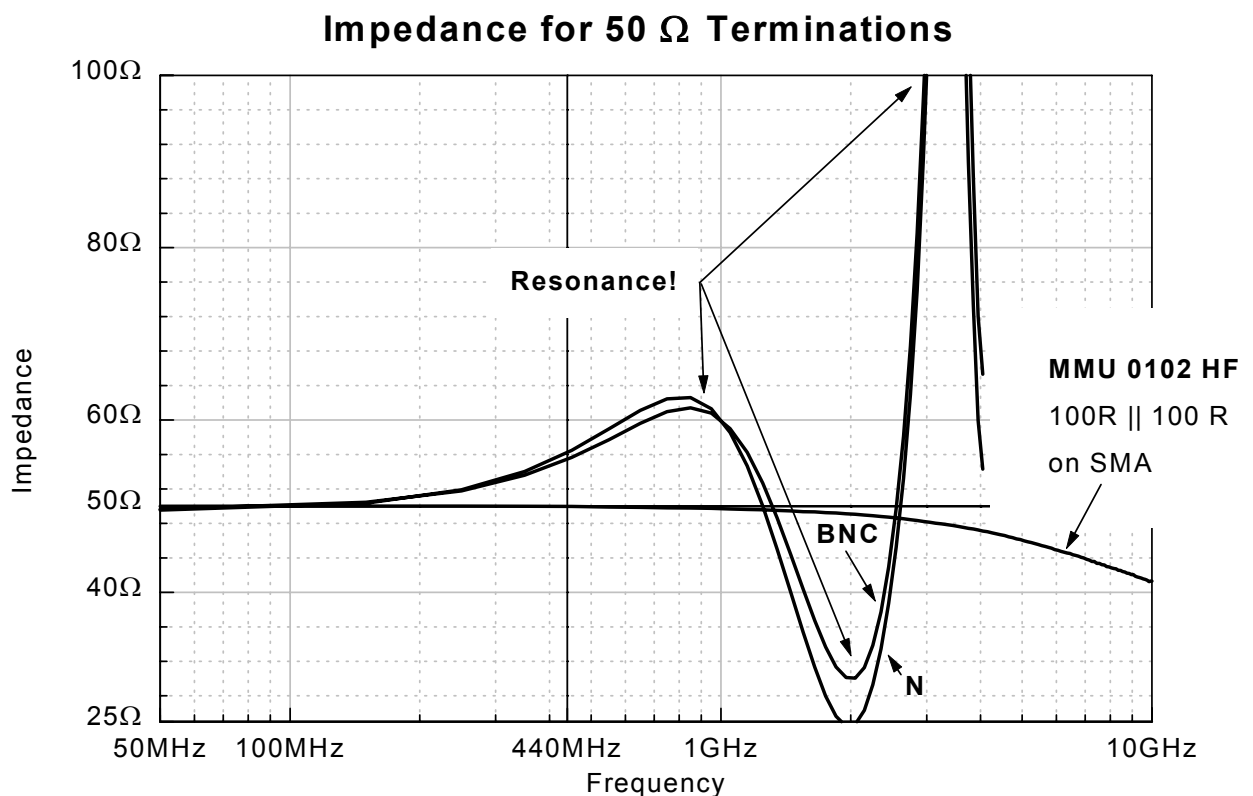

Return Loss for 50 Ω Terminations

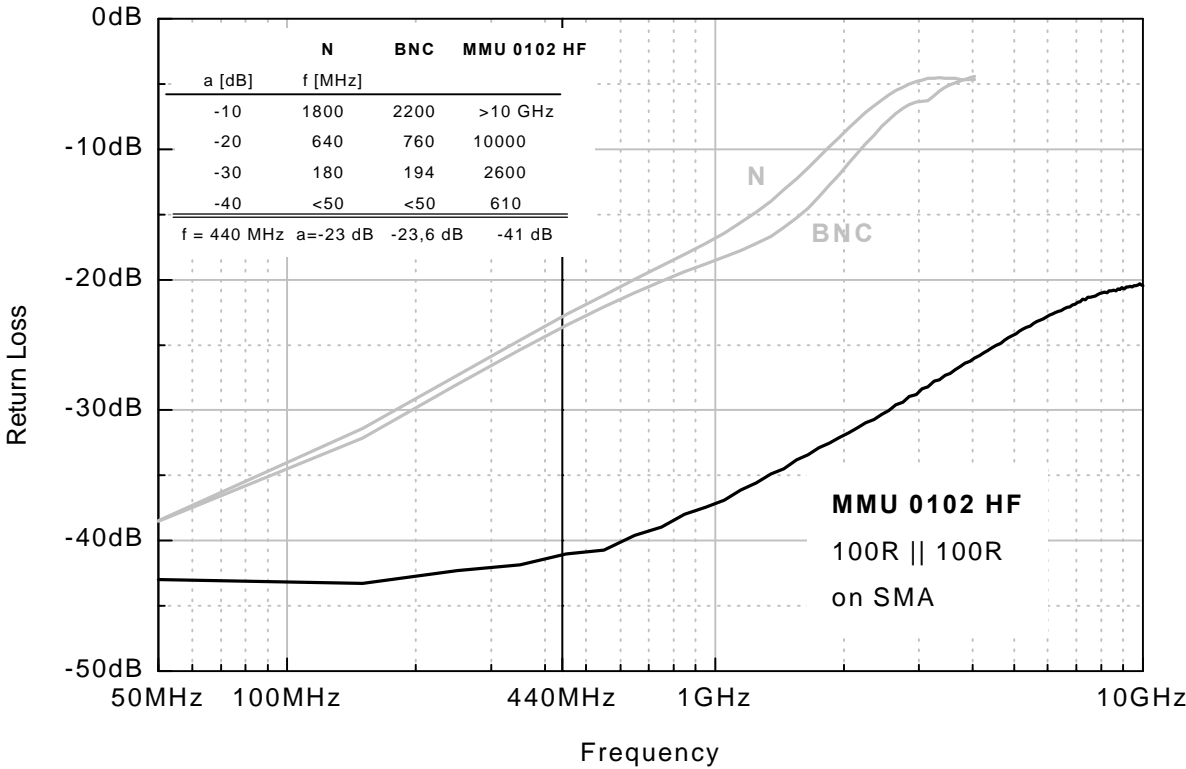

Phase Angle for 50 Ω Terminations

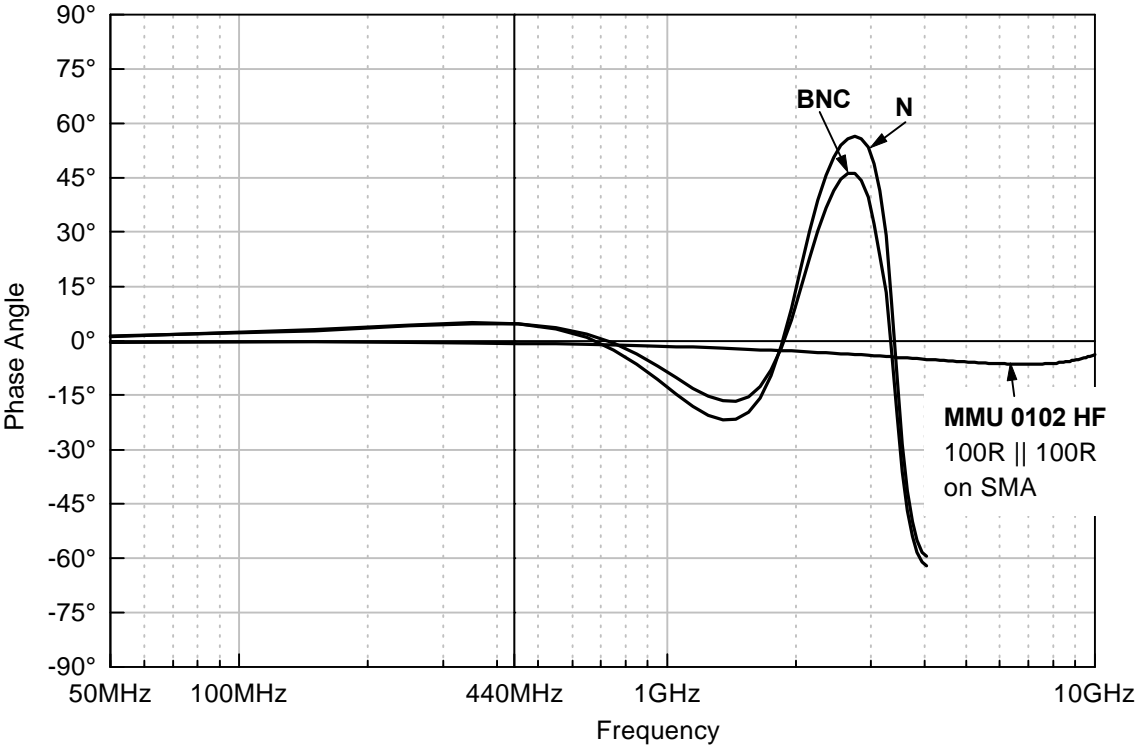

5. Data Sheets

Resistance Range	Ω	6,8 – 470; 50
E-Series		E 24
Tolerance	%	2
Temperature Coefficient		TC 50
Climatic Category		55 / 125 / 56

Product Selection Guide HF-Resistors

MCT 0603 HF	General Purpose HF-Resistor, Flat Chip
MMB 0207 HF	Power HF-Resistor, $P_{70} = 1 \text{ W}$
MMA 0204 HF	General Purpose HF-Resistor, Tolerance 1 %
MMU 0102 HF	Miniaturization, best HF-Behaviour

Resistance Range HF-Resistors

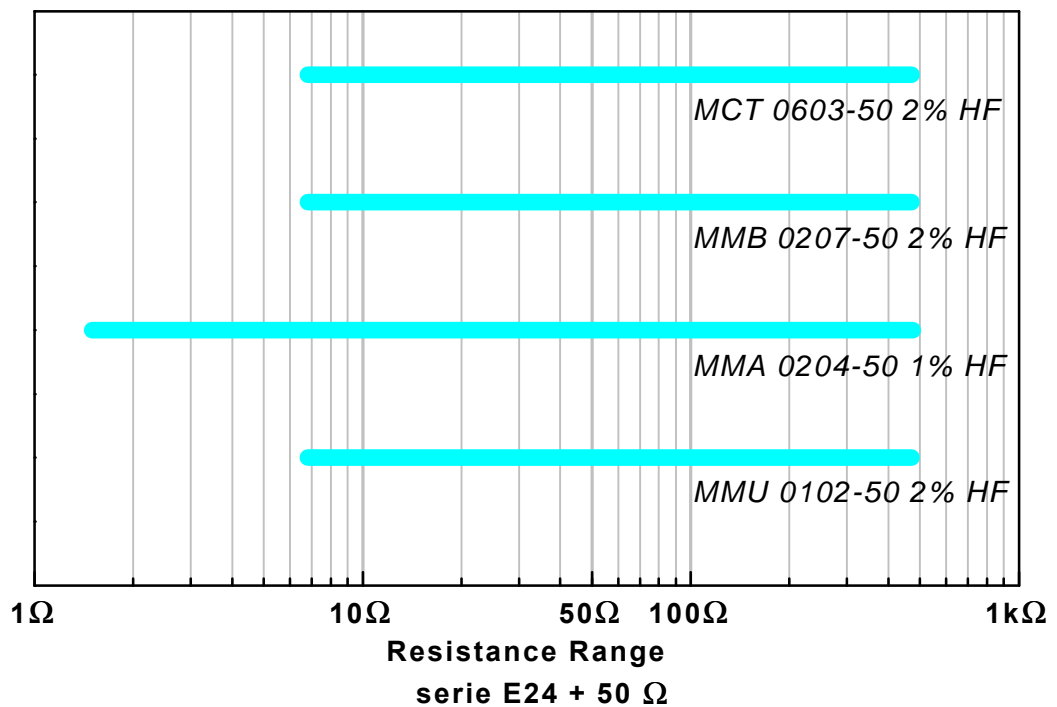

MCT 0603 HF

- **Speciality Product for RF Applications**
 - **Low-Inductance Trimmed Product**
 - **Suitable for more than 10 GHz**
 - **Resistance Range: 6,8 Ω through 470 Ω**
 - **Size:**

Inch	0603
Metric	1608
-

MCT - HF Speciality Thin Film Flat Chip Resistors for RF applications is the perfect choice in high frequency circuit designs where the impedance change due to the parasitic inductance of regular and professional resistors can not be accepted. Typical applications are in the fields of telecommunication equipment and industrial electronics.

The production of the **MCT - HF Speciality Thin Film Flat Chip Resistor** for RF applications strictly follows an extensive set of instructions established for reproducibility. A homogeneous film of metal alloy is deposited on a high grade (96 % Al_2O_3) ceramic body and conditioned to achieve the desired temperature coefficient. Specially designed pre contacts are deposited on both sides using the same thin film technology. A special laser is used to achieve the target value by smoothly cutting a low-inductivity groove in the resistive layer without damaging the ceramics. The resistor elements are covered by a blue protective coating designed for electrical, mechanical and climatic protection. The terminations receive a final pure tin on nickel plating.

The result of the determined production is verified by an extensive testing procedure performed on 100 % of the individual chip resistors. Only accepted products are laid directly into the paper tape according to **IEC 60 286-3**.

The resistors are suitable for processing on automatic SMD assembly systems. They are suitable for automatic soldering using wave, reflow or vapour phase. The encapsulation is resistant to all cleaning solvents commonly used in the electronics industry, including alcohols, esters and aqueous solutions.

The resistors are tested according to **IEC 60 115** and **IEC 60 068**. They meet most of the requirements of **CECC 40 401-801**.

BEYSCHLAG has achieved "**Approval Of Manufacturer**" according to **EN 100 114-1**. The release certificate for "**Technology Approval Schedule**" according to **CECC 240 001** is granted for the BEYSCHLAG manufacturing process.

Electrical Data

Style		MCT 0603 HF	
Resistance Range	Ω	6,8 – 470; 50	
E-Series		E 24	
Tolerance	%	2	
Temperature Coefficient		TC 50	
Climatic Category		55 / 125 / 56	
Operation Mode		Standard	Power
Film Temperature	$^{\circ}\text{C}$	125	155
Specified Lifetime	h	225 000	8 000
Thermal Resistance R_{th}	K/W	550	
Rated Dissipation P_{70}	W	0,1	0,125
The specification for standard operation mode ensures a maximum temperature of 110 $^{\circ}\text{C}$ at the solder joint on test boards according to CECC 00802			

Max. Resistance Change at P_{70} for Resistance Range		10 Ω - 470 Ω	
$\Delta R/R$ after ...			
... 1 000 h	%	$\leq 0,5$	$\leq 1,0$
... 8 000 h		$\leq 1,0$	$\leq 2,0$
... 225 000 h		$\leq 3,0$	

Operating Voltage, V_{max} AC/DC	V	75	
Permissible Voltage against Ambient ...			
... 1 minute	V	100	
... continuous	V	75	
Isolation Resistance	Ω	$> 10^9$	

Performance Characteristics

BEYSCHLAG Metal film MELF Resistors fulfill the requirements of the following specifications:

- EN 140 000: 1993 Generic specification "Fixed Resistors"
- EN 140 400: 1996 Sectional specification "Fixed low power surface mounting resistors"

Derating

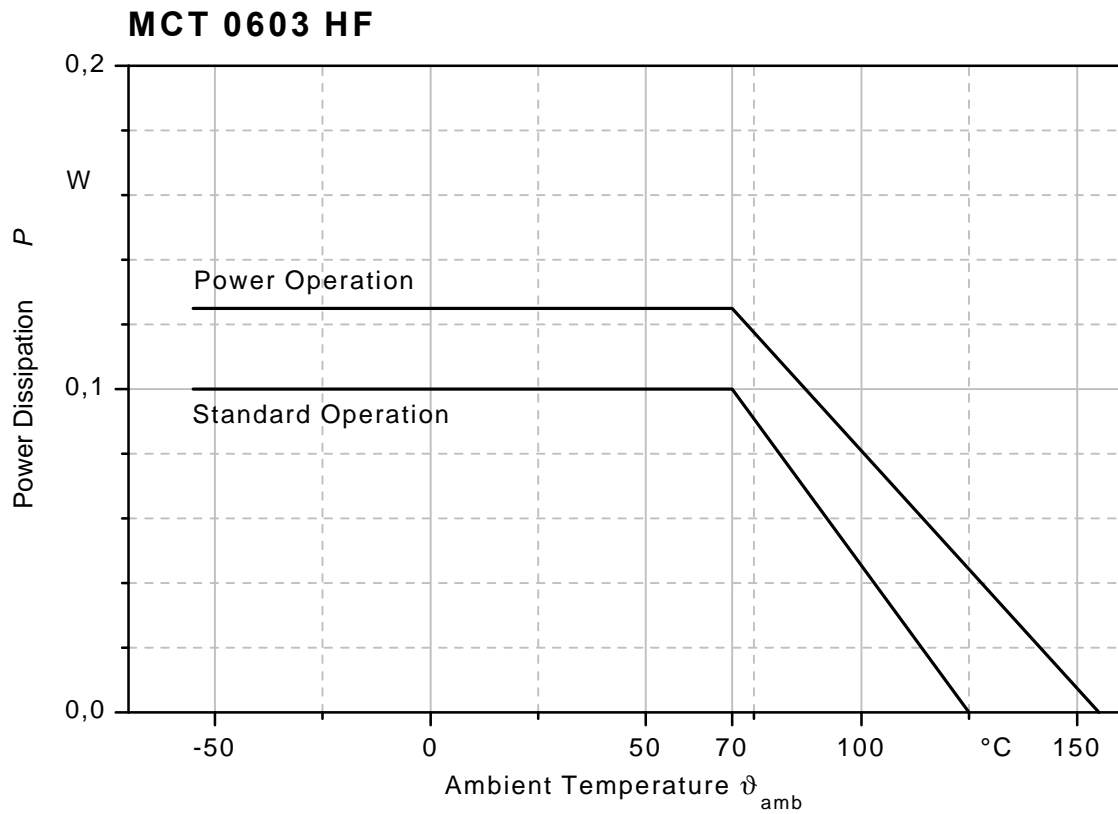

RF-Behaviour

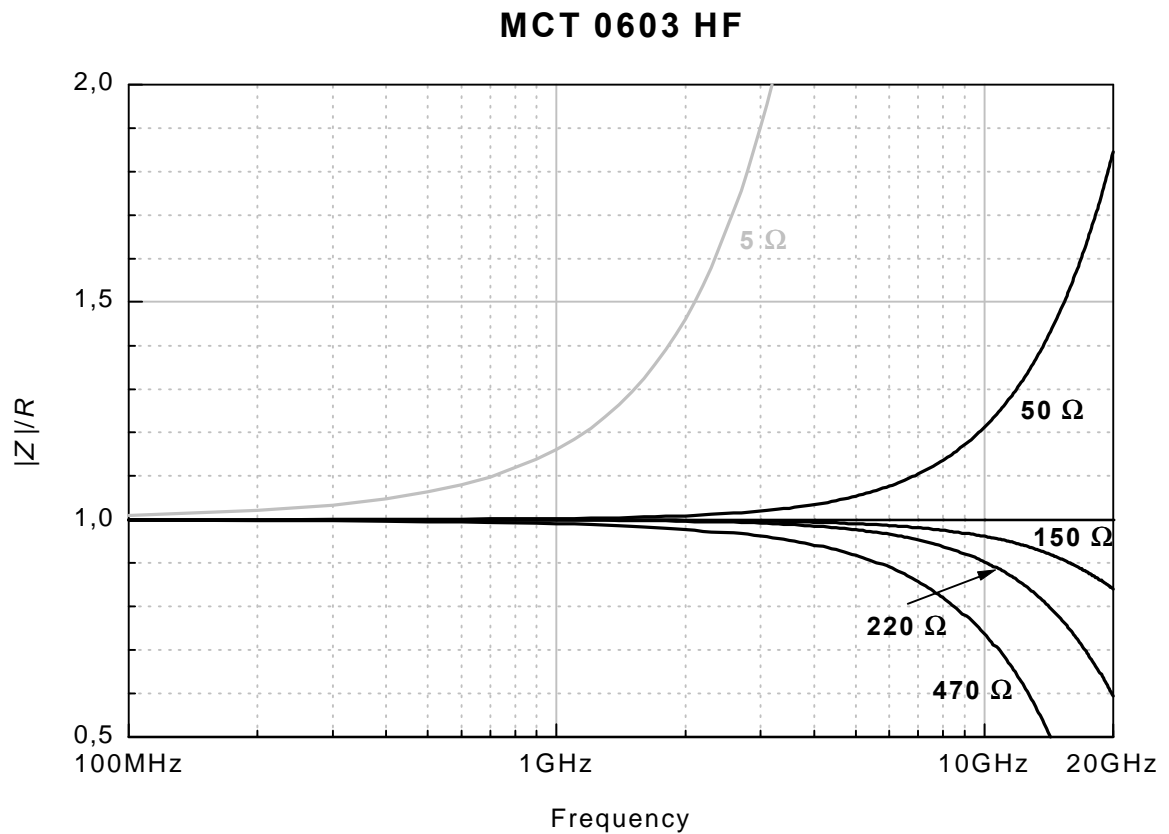

Tests	IEC 60 115-1 Clause	IEC 60 068-2- (method)	Test Condition	Permissible Change ΔR
				MCT 0603 HF
Short-Time Overload *)	4.13		2,5 x rated voltage / 2 x V_{max} for 2 s	$\pm(0,5\%R+0,05\Omega)$
Low Temperature Operation		1 (Aa)	-55 °C / 2 h	$\pm(0,5\%R+0,05\Omega)$
Rapid Change of Temperature *)	4.19	14 (Na)	5 cycles between -55 °C / +125 °C	$\pm(0,5\%R+0,05\Omega)$
Endurance at ...	4.25.1		Rated voltage / V_{max} 1,5 h on / 0,5 h off	
... +70 °C / 1 000 h				$\pm(0,5\%R+0,05\Omega)$
... +70 °C / 8 000 h				$\pm(1\%R+0,05\Omega)$
Climatic Sequence *)	4.23	30 (D)	Dry heat - damp heat (1 cycle) - cold - low air pressure - damp heat (5 cycles)	$\pm(1\%R+0,05\Omega)$
Damp Heat, Steady State 56 Days *)	4.24	3 (Ca)	+40 °C / 93 % R.H.	$\pm(1\%R+0,05\Omega)$
Endurance at UCT / 1 000 h	4.25.3	27 (Ba)	UCT = +125 °C	$\pm(1\%R+0,05\Omega)$
				Requirements
Thermal Adhesion (shear test)			CECC 00 802 / B.2 5 N / 10 s	No visible damage
Voltage Proof (dielectric withstanding voltage)	4.7		$V_{rms} = 100 \text{ V} / 60 \text{ s}$	No flashover or breakdown
Solderability	4.17.2	20 (Ta)	+215 °C / 3 s	Dipped area shall be covered with a smooth and bright solder coating of at least 95 %
Resistance against Solvents *)		45 (xA)	Alcohols, ester, hydrous solution, +23 °C, tooth brush method	No mechanical damage Marking must be legible
Soldering			Infrared-Reflow Soldering	

*) Resistors mounted on a test board according to CECC 00 802

MMU 0102 HF, MMA 0204 HF, MMB 0207 HF

- **Speciality Product for RF Applications**
 - **Low-Inductance Non-Helical Trimmed Product**
 - **Suitable for more than 20 GHz**
 - **Resistance Range: 1,5 Ω through 475 Ω**
 - **Sizes:**

DIN:	0102	0204	0207
CECC:	RC2211	RC3715	RC6123
-

MMU - HF and MMA - HF Speciality Thin Film MELF Resistors for RF applications are the perfect choice in high frequency circuit designs where the impedance change due to the parasitic inductance of regular and professional resistors can not be accepted. Typical applications are in the fields of telecommunication equipment and industrial electronics.

In special situations where MMU - HF or MMA - HF Resistors were mounted to a solid ground plane or module case, the rated power dissipation could have been exceeded by far.

The production of the **MMU - HF and MMA - HF Speciality Thin Film MELF Resistors** for RF applications strictly follows an extensive set of instructions established for reproducibility. A homogeneous film of metal alloy is deposited on a high-grade (85 % Al_2O_3 , for MICRO-MELF: 96 % Al_2O_3) ceramic body and conditioned to achieve the desired temperature coefficient. Nickel plated steel termination caps are firmly pressed on the metallized rods. A special laser is used to achieve the target value by smoothly cutting a low-inductivity non-helical groove in the resistive layer without damaging the ceramics. The resistors are covered by a base coating and a light blue outer lacquer. This encapsulation provides electrical, mechanical and climatic protection. Four or five colour code rings designate the resistance value and tolerance according to **IEC 60 062**.

The result of the determined production is verified by an extensive testing procedure performed on 100 % of the individual resistors. Only accepted products are laid directly into the blister tape according to **IEC 60 286-3**.

The resistors are suitable for processing on automatic SMD assembly systems. They are suitable for automatic soldering using wave, reflow or vapour phase. The encapsulation is resistant to all cleaning solvents commonly used in the electronics industry, including alcohols, esters and aqueous solutions.

The resistors are tested according to **IEC 60 115** and **IEC 60 068**. They meet most of the requirements of **CECC 40 401-803**.

BEYSCHLAG has achieved "**Approval Of Manufacturer**" according to **EN 100 114-1**. The release certificate for "**Technology Approval Schedule**" according to **CECC 240 001** is granted for the BEYSCHLAG manufacturing process.

Electrical Data

Style			MMU 0102 HF		MMA 0204 HF		MMB 0207 HF	
Resistance Range	Ω		6,8 – 470; 50		1,5 – 475; 50		6,8 – 470; 50	
E-Series			E 24		E 24, E 96		E 24	
Tolerance	%		2		1		2	
Temperature Coefficient			TC 50		TC 50		TC 50	
Climatic Category			55 / 125 / 56		55 / 125 / 56		55 / 125 / 56	
Operation Mode			Standard	Power	Standard	Power	Standard	Power
Film Temperature	$^{\circ}\text{C}$		125	155	125	155	125	155
Specified Lifetime	h		225 000	8 000	225 000	8 000	225 000	8 000
Thermal Resistance R_{th}	K/W		250		200		140	85
Rated Dissipation P_{70}	W		0,2	0,3	0,25	0,4	0,4	1,0
The specification for standard operation mode ensures a maximum temperature of 110 $^{\circ}\text{C}$ at the solder joint on test boards according to CECC 00802								

Max. Resistance Change at P_{70} for Resistance Range			10 Ω - 470 Ω		10 Ω - 470 Ω		10 Ω - 470 Ω	
$\Delta R/R$ after ...								
... 1 000 h	%		$\leq 0,25$	$\leq 0,5$	$\leq 0,25$	$\leq 0,5$	$\leq 0,25$	$\leq 0,5$
... 8 000 h			$\leq 0,5$	$\leq 1,0$	$\leq 0,5$	$\leq 1,0$	$\leq 0,5$	$\leq 1,0$
... 225 000 h			$\leq 1,5$		$\leq 1,5$		$\leq 1,5$	

Operating Voltage, V_{max} AC/DC	V		150	200	300
Permissible Voltage against Ambient ...					
... 1 minute	V		150	300	500
... continuous	V		75	75	75
Isolation Resistance	Ω		$> 10^{10}$	$> 10^{10}$	$> 10^{10}$

Performance Characteristics

BEYSCHLAG Metal film MELF Resistors fulfill the requirements of the following specifications:

- EN 140 000: 1993** Generic specification "Fixed Resistors"
EN 140 400: 1996 Sectional specification "Fixed low power surface mounting resistors"

Derating

Standard Operation

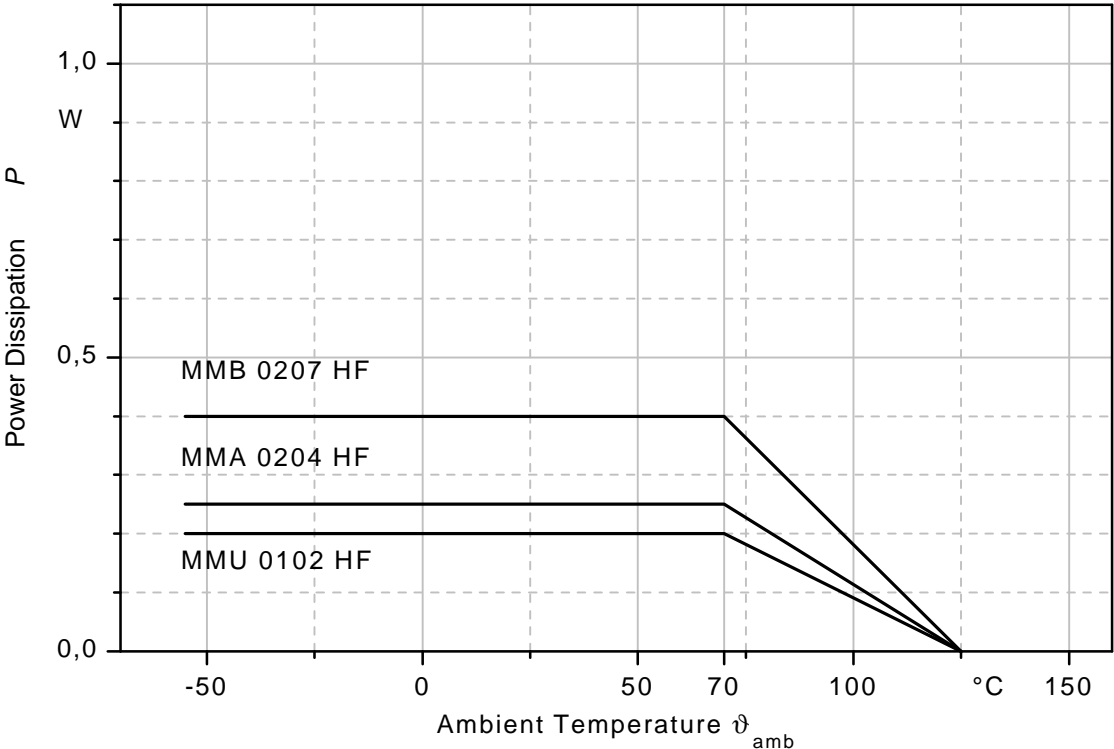

Power Operation

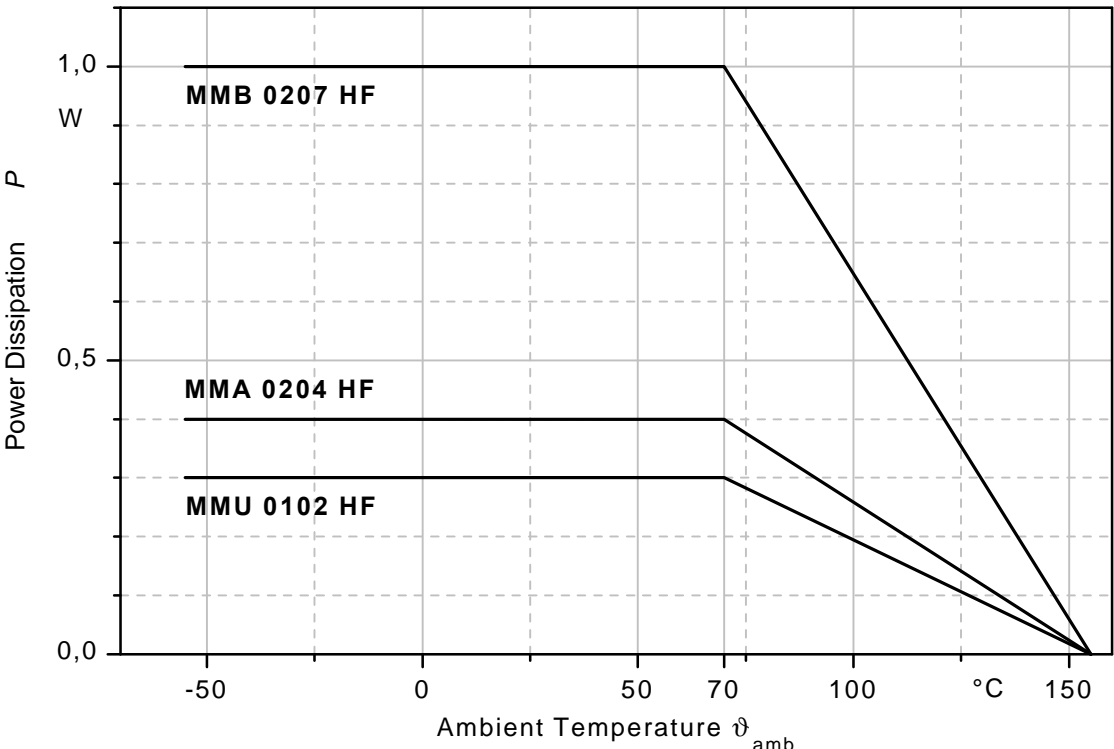

RF-Behaviour

MMU 0102 HF

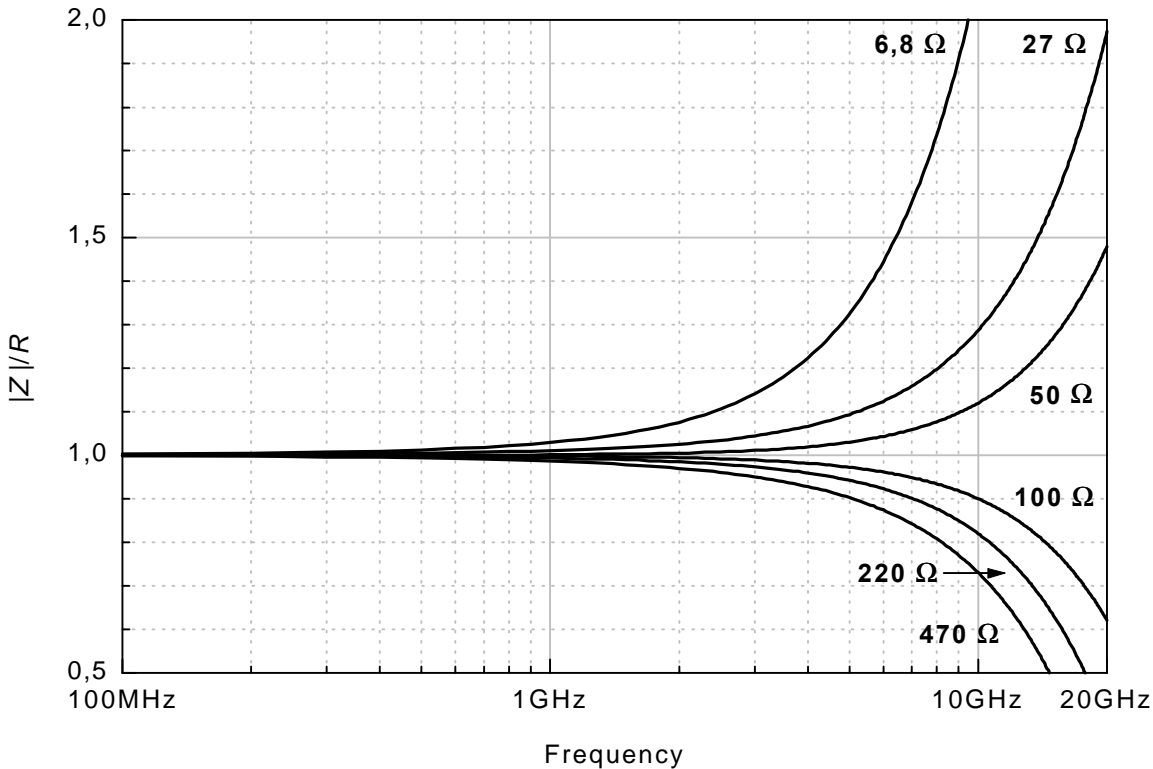

MMA 0204 HF

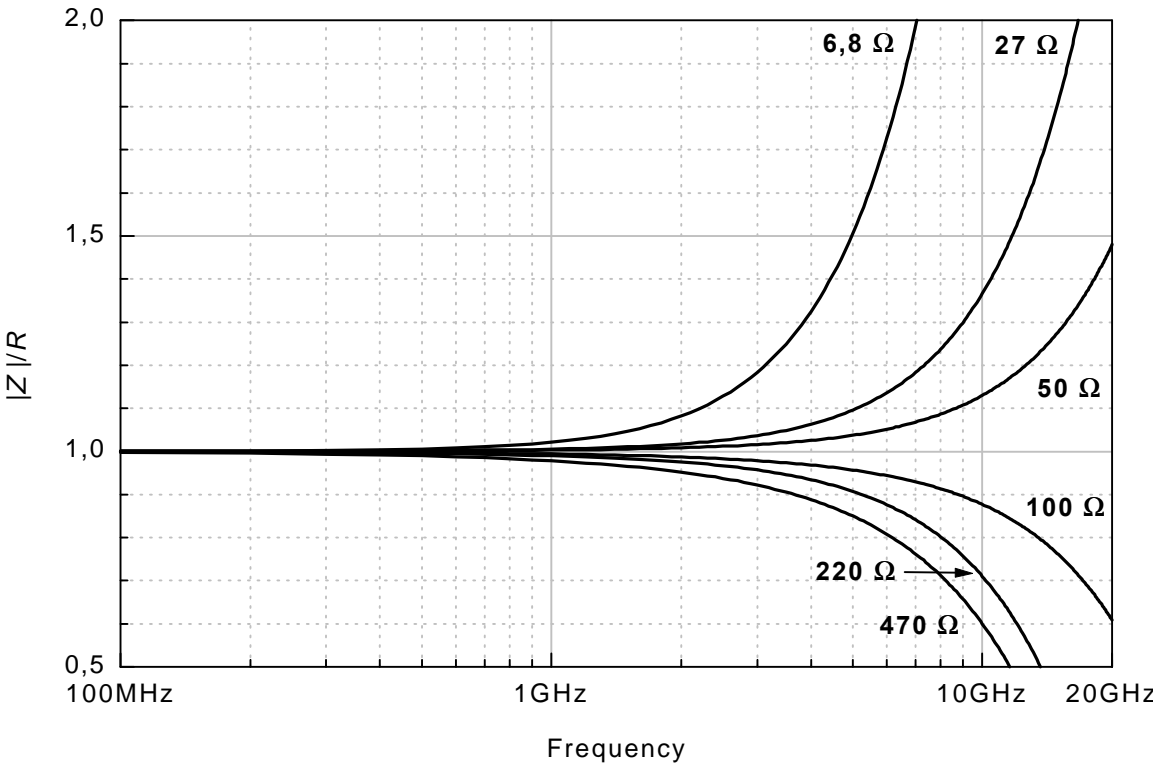

MMB 0207 HF

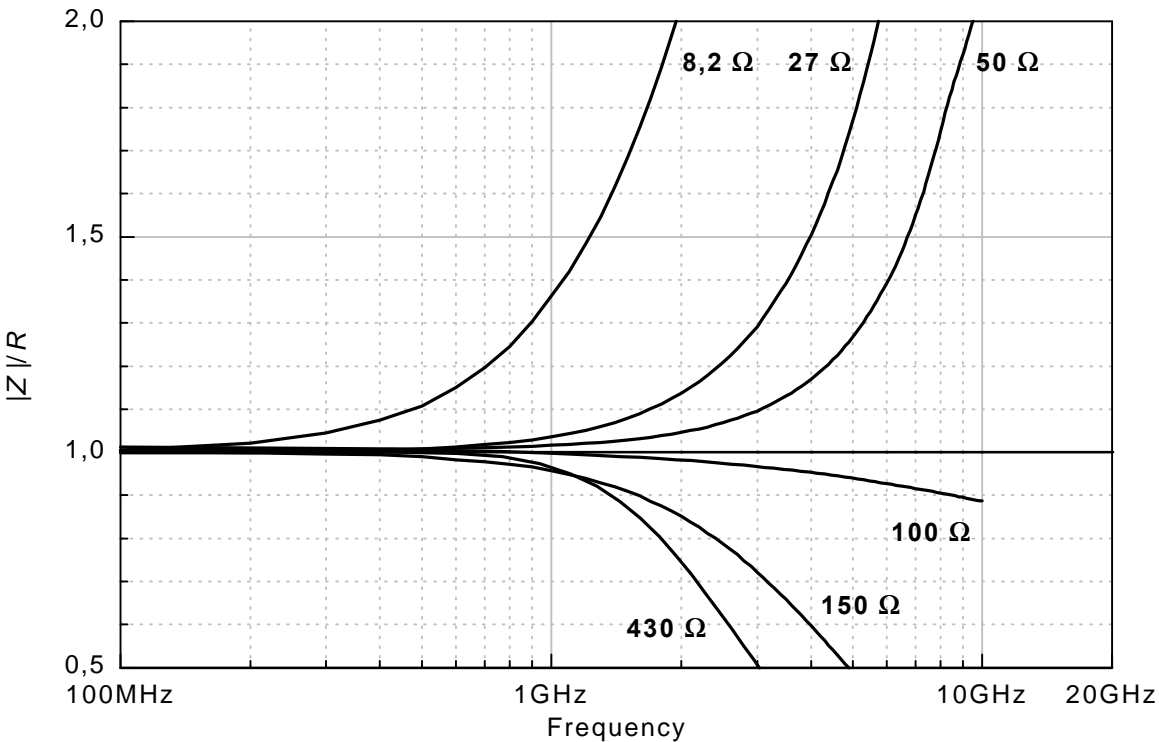

Tests

	IEC 60 115-1 Clause	IEC 60 068-2- (method)	Test Condition	Permissible Change ΔR
			MMU 0102 HF MMA 0204 HF MMB 0207 HF	10 Ω - 470 Ω 10 Ω - 470 Ω 10 Ω - 470 Ω
Short-Time Overload *)	4.13		2,5 x rated voltage / 2 x V_{max} for 2 s	$\pm(0,25\%R+0,05\Omega)$
Low Temperature Operation		1 (Aa)	-55 °C / 2 h	$\pm(0,25\%R+0,05\Omega)$
Resistance to Soldering Heat	4.18.2	20 (Tb)	+260 °C / 10 s	$\pm(1\%R+0,05\Omega)$
Rapid Change of Temperature *)	4.19	14 (Na)	5 cycles between -55 °C / +125 °C	$\pm(0,5\%R+0,05\Omega)$
Endurance at ...	4.25.1		Rated voltage / V_{max} 1,5 h on / 0,5 h off	
... +70 °C / 1 000 h				$\pm(0,25\%R+0,05\Omega)$
... +70 °C / 8 000 h				$\pm(0,5\%R+0,05\Omega)$
Climatic Sequence *)	4.23	30 (D)	Dry heat - damp heat (1 cycle) - cold - low air pressure - damp heat (5 cycles)	$\pm(1\%R+0,05\Omega)$
Damp Heat, Steady State 56 Days *)	4.24	3 (Ca)	+40 °C / 93 % R.H.	$\pm(1\%R+0,05\Omega)$
Endurance at UCT / 1 000 h	4.25.3	27 (Ba)	UCT = +125 °C	$\pm(1\%R+0,05\Omega)$
				Requirements
Thermal Adhesion (shear test)			CECC 00 802 / B.2 5 N / 10 s	No visible damage
Voltage Proof (dielectric withstanding voltage)	4.7		$V_{rms} = 100 V / 60 s$	No flashover or breakdown
Solderability	4.17.2	20 (Ta)	+215 °C / 3 s	Dipped area shall be covered with a smooth and bright solder coating of at least 95 %
Resistance against Solvents *)		45 (xA)	Alcohols, ester, hydrous solution, +23 °C, tooth brush method	No mechanical damage Marking must be legible

*) Resistors mounted on a test board according to CECC 00 802

Engineering Support & Design in

- Samples for evaluation in own circuit design
- Sample sheets with 16 values for HF circuits
- Sample sheets with 4 different sizes and 2 values for comparison of size
- Special print: “Resistors in Microwave Applications”
- Data sheets: “HF-Resistors Made by BEYSCHLAG”
- Brochure: “The HF-Resistor Application Guide including Data Sheets of HF-Resistors Made by BEYSCHLAG”
- Personal consulting by the manufacturer
- Current catalogue: “Resistor Products”

Acknowledgement

Most of the measurements on high frequency behaviour are done with the grateful assistance by the Fachhochschule Westküste, Heide, Germany.

Comments and questions related to this topic

are welcome. Please send them to

BEYSCHLAG GmbH

Application Marketing

P.O. Box 1220

D-25732 Heide

Germany

Tel. +49-481-95-0

Fax. +49-481-95-204