

Thermal Cutoff Fuses

U.S. Electronics Inc

Ph: (314) 423 7550

Fax: (314) 423 0585

USW SERIES



PRODUCTS

▶ [USW -1 Series](#)

▶ [USW-2 Series](#)

OVERVIEW

The thermal cutoffs (TCO) are non resetting, thermally sensitive, single pole, normally closed devices and are intended to be used in various appliances. A temperature sensitive thermal fuse melts and opens electrical contacts when temperatures exceed the rating of the thermal fuse. Thermal cutoffs are providing protection against potentially hazardous overheating conditions in billions of products around the world.

Standard product offerings include:

Thermal Fuse

- * Metallic Case type (Axial, Spring Action, Current : 10A ,15A) - **USW-1 Series**
- * Low melting alloy type (Axial, Surface tension type, Current : 2A, 5A) - **USW-2 Series**

Note that the TCO shall be connected at the readily detectable location when abnormal conditions such as thermostat failure, fan failure, locked rotor, dry operation, etc., might occur in the appliance.

TCO is designed to lessen the heat created from TCO itself, but there may be a difference between the ambient temperature and operating temperature of TCO due to wrong connection method.

In order to minimize the difference between ambient temperature and operating temperature of TCO, it is

recommended that the creation of heat can be minimized around the TCO connected area under normal operating condition, but the heat generation can be maximized at TCO connected area under abnormal condition.

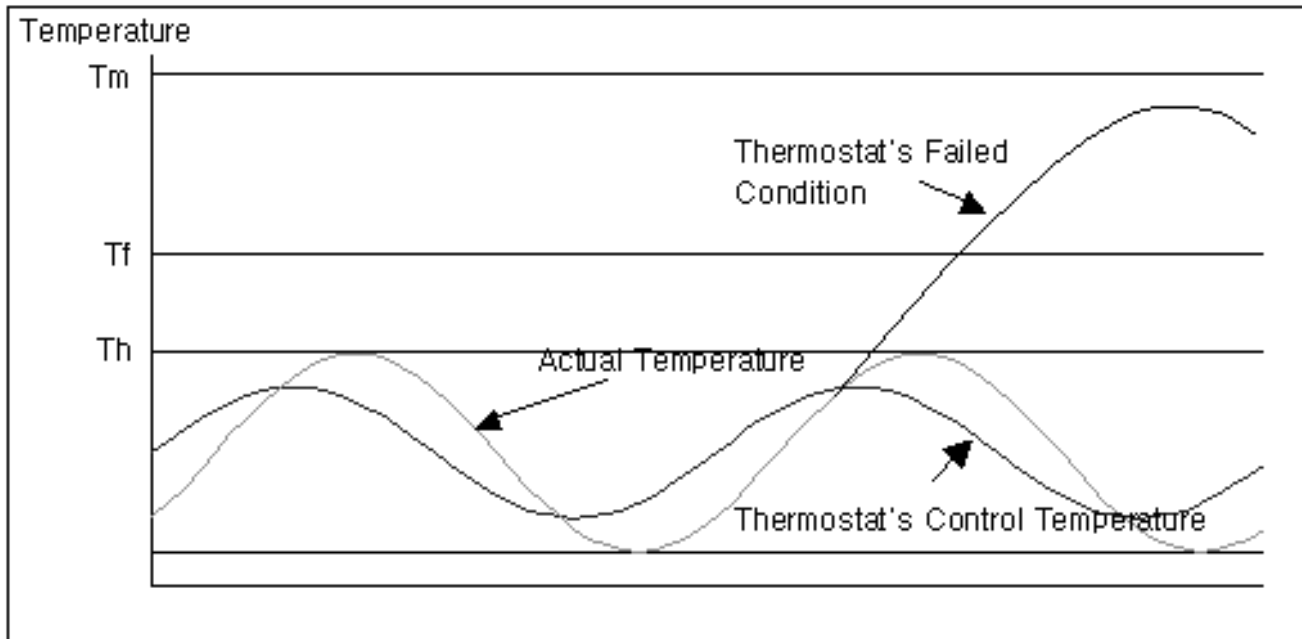

- ▶ Each TCO has specific electrical and temperature ratings. Each TCO must be used within the prescribed ratings. These ratings include Rated Function temperature(TF) ,Holding Temperature(TH), Maximum Temperature (TM), and the electrical ratings.
- ▶ It is recommended the TCO connection shall be selected at the location in the end-use appliances where the undue stresses due to the vibration or other movement of parts does not apply.
- ▶ TCO shall be in the location not coming into contact with the liquids and high humidity in certain appliances like coffee makers.
- ▶ The end product should be designed so that TCO does not see any unusual condition exceeding its Maximum Temperature(Tm) in overshoot situation when TCO has functioned.
- ▶ The end product should be designed so that TCO detects only the intended heat source.For example, in a heater, TCO should not be connected directly to heater wire so that heat conductance through the lead wire does not accelerate the cut-off of the TCO.
- ▶ Avoid all heat sources except the heat being detected. Although TCO are highly reliable, there are limits to the abnormal states with which a single TCO can cope. Further, if a TCO is damaged for some reason, it is possible that it will not break a current under abnormal conditions. If there is a possibility that personal or property damage would arise if a circuit is not broken during abnormal equipment operation (i.e. when there is a high required safety level), it is effective to add one of more TCO with different Tf.

LEAD FORMING

It is easy to bend the copper lead as it is flexible. But it is likely to be damaged or broken if TCO lead is repeatedly bent over 90°. When forming the lead, be careful not to apply the forming force direct to TCO body.

*** Forming Sealant Lead Wire**

Bend the lead wire at least 4 mm away from the seal. The damage of the sealant worsen the air tightness. Note that bending is conducted with care, since the worse air tightness impedes the normal operation of TCO. Holders or tools used during lead forming must not grasp the body, but lead wire. Doing so can protect from damage to the body of TCO.

*** Forming lead wire other than sealed lead**

Bend at least 4mm away from TCO body, since excessive force to the body causes the deformation of TCO case.

PRECAUTION FOR LEAD CONNECTION

- * Be careful to be free from damage, burn, nick, crack or overheating at TCO seal or body. If there are such damage as above, do not use.
- * Experimental assembly trials should be made to check the damage of lead wire, seal or TCO body.
- * When connecting wire to TCO, it is recommended that splice or terminal shall be used. The material of splice or terminal should be corrosion resistant.
- * When securing the splice or terminal to TCO, be careful not to damage the TCO body. The material of splice or terminal should be low heat resistace. Be careful not to cause excessive overheating due to poor connection method. It should be noted that the connection wire shall be flexible standard wire. If using solid wire, use the bending process.

SOLDERING OF LEAD

The following points should be noted if soldering is used to connect TCO lead.

- * Do soldering work on lead as far away from the TCO body if possible.
- * Be careful to minimize the heat transfer to TCO body. When proper means to prevent the heat transfer is not provided, TCO seal or body may be damaged and broken-down.
- * To shorten the working time, employ pre-soldering process at the intended soldering area.
- * Soldering Method to prevent heat.(use heatsink)

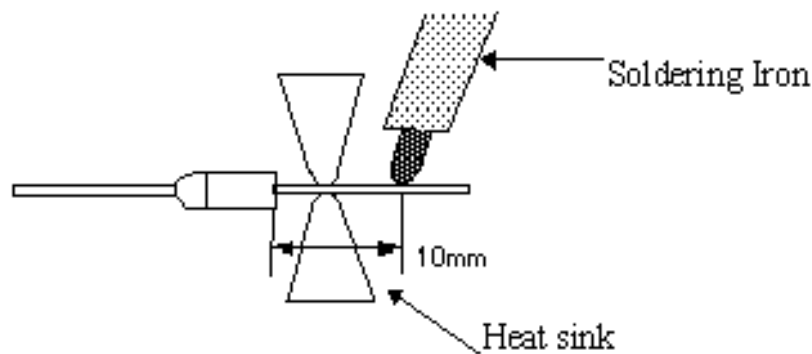

- * Mechanical security must not depend on solder alone.
- * Electric current must not pass through inner electric contact or the case of TCO when soldering. The passing of excess current damages the TCO element or case.
- * **Tensile strength of lead**
Pull force shall not be over 2kg and push force shall not be over 0.5 kg.
- * **Strength of Case**
Applying the excessive force to tie the case body causes deformation and effects normal operation of TCO. Since this may cause the fuse to not properly operate, be sure to avoid the excessive tying force.
- * **Functioning Temperature Test**
Install the TCO in a chamber and gradually increasing temperature upto 20°C lower than T_f , then if the temperature of the chamber and the testing products are made equal, the temperature is increased 1°C per minute, then the fuse will function within the specified tolerance.
- * **Temperature Increase Test**
When normal operating voltage and current are applied to the TCO in ambient temperature ($20\sim 25$) $^{\circ}\text{C}$ the temperature of the TCO will go up. But the increase of temperature shall not be more than 10°C
- * **Insulation Resistance**
After having operated in temperature test, the insulation resistance shall be more than 0.2 ohms when tested with 500V resistance measuring machine.
- * **Contact Resistance Test**
The resistance of the both leads of the TCO should not exceed 1.5 ohms within the 10mm length of the leads.
- * **Dielectric Voltage Withstand Test**
After conducting the Insulation resistance test, the TCO shall be maintained without breakdown when AC 500V is applied between the leads of the TCO for 1 Min.

*** Humidity Test**

After keeping the TCO in the chamber with humidity 90~95% and specified below condition for 500 hours, the TCO shall pass the Functioning temperature test.

Tf	Chamber Temperature	Humidity
100 °C less	40 ± 2 °C	90~95%
100 °C over	65 ± 2 °C	

*** Aging Test**

After keeping the TCO at the temperature $20 \pm 3 \text{ }^\circ\text{C}$ lower then the Tf for 48 hours, the TCO shall pass the Functioning temperature test

*** Temperature Rise Graph**

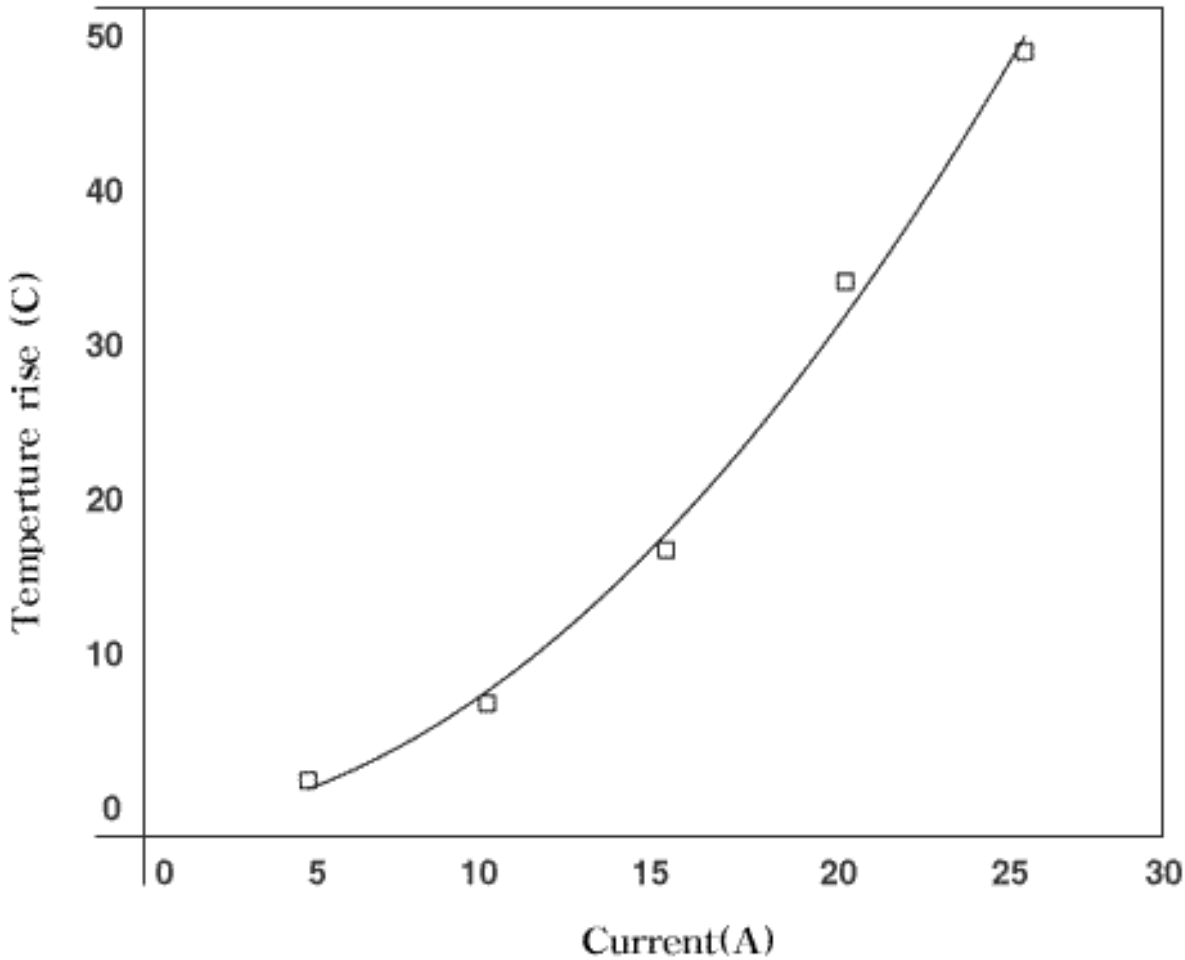

Thermal Cutoff Fuses

USW-1 SERIES

U.S. Electronics Inc

Ph: (314) 423 7550

Fax: (314) 423 0585

TEMPERATURE

Part No.	Tf	Cutoff Temperature	Th
USW-102T	72°C(161.6°F)	70°C+2°C-2°C	47°C(116.6°F)
USW-105T	77°C(170.6°F)	76°C+0°C-4°C	52°C(125.6°F)
USW-109T*	84°C(183.2°F)	84°C+0°C-4°C	57°C(134.6°F)
USW-104T	98°C(208.4°F)	96°C+2°C-2°C	73°C(163.4°F)
USW-108T*	100°C(212°F)	99°C+0°C-4°C	75°C(167°F)
USW-110T*	109°C(228.2°F)	109°C+0°C-4°C	84°C(183.2°F)
USW-111T	119°C(248.2°F)	119°C+0°C-4°C	94°C(201.2°F)
USW-115T	126°C(258.8°F)	126°C+0°C-4°C	100°C(212°F)
USW-129T	128°C(262.4°F)	128°C+0°C-4°C	103°C(217.4°F)
USW-114T	139°C(282.2°F)	139°C+0°C-4°C	114°C(237.2°F)
USW-138T	144°C(191.2°F)	144°C+0°C-4°C	119°C(246.2°F)
USW-116T	152°C(305..6°F)	152°C+0°C-4°C	127°C(260.6°F)
USW-120T	167°C(332.6°F)	167°C+0°C-4°C	144°C(291.2°F)
USW-118T	169°C(336.2°F)	169°C+0°C-4°C	144°C(291.2°F)
USW-127T	184°C(363.2°F)	184°C+0°C-5°C	159°C(318.2°F)
USW-122T	192°C(337.6°F)	188°C+3°C-3°C	162°C(323.6°F)
USW-125T	195°C(383°F)	195°C+0°C-5°C	165°C(329°F)
USW-139T	216°C(420.8°F)	216°C+0°C-6°C	178°C(352.4°F)
USW-128T	240°C(464°F)	240°C+0°C-6°C	193°C(379.4°F)

Most of the models have CUL,TUL and UL approval.UL File No: E126429

*Dual Ratings(UL approved) - 250V 10A and 125V 15A

ELECTRICAL

* RATED VOLTAGE : 250VAC and 125VAC

* RATED CURRENT : 10A at 250VAC and 15A at 125VAC

* INTERRUPTING CURRENT : 250VAC, 15A

* TRANSIENT OVERLOAD TEST CURRENT : dc current pulses, with an amplitude 150A and a duration of 3 ms with 10 s intervals, are applied for 100 successive cycles through the current path.

EXPLANATION OF RATINGS

A. RATED FUNCTIONING TEMPERATURE (TF, Tf)

The temperature at which a thermal cutoff changes its state of conductivity to open circuit with detection current as the only load. The tolerance according to UL 1020 is + 0, - 10°C.

B. HOLDING TEMPERATURE (TH, Tc)

The maximum temperature at which a thermal cutoff can be maintained while conducting rated current for 168 hours which will not cause a change in the state of conductivity to open circuit.

C. RATED CURRENT

The maximum current which the thermal cutoff is able to carry for a specified time at Tc without alteration of its Functioning Temperature.

D. INTERRUPTING CURRENT

The value of the current that the thermal cutoff is capable of interrupting safely at rated voltage and under specified circuit conditions.

E. TRANSIENT OVERLOAD CURRENT

A direct current pulse train, which the thermal cutoff is able to withstand without impairing its characteristics.

F. RATED VOLTAGE

The voltage used to classify a thermal cutoff.

DIMENSIONS

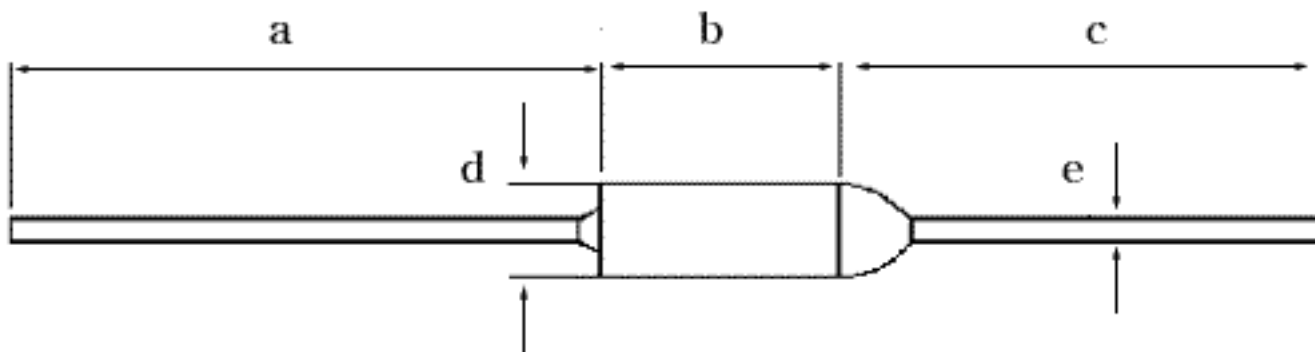

Dimension(mm)	a	b	c	d	e
long	35.0 ±3.5	10.5 ±0.5	35 ±3.5	4.0 ±0.2	1.0(18AWG)
medium	35.0 ±3.5	10.5 ±0.5	25 ±3.5	4.0 ±0.2	1.0(18AWG)
short	35.0 ±3.5	10.5 ±0.5	18 ±2.5	4.0 ±0.2	1.0(18AWG)

Thermal Cutoff Fuses

U.S. Electronics Inc

Ph: (314) 423 7550

USW-2 SERIES

Fax: (314) 423 0585

TEMPERATURE

Part No.	Tf	Tf Tolerance	Th
USW-211T	102°C(241.2°F)	+ 0 °C,-6 °C	70°C(183.6°F)
USW-210T	115°C(264.6°F)		85°C(210.6°F)
USW-215T	130°C(291.6°F)		95°C(228.6°F)
USW-216T	133°C(297°F)		100°C(237.6°F)
USW-217T	139°C(307.8°F)		105°C(246.6°F)
USW-225T	150°C(327.6°F)		120°C(273.6°F)

*Most of the models have CUL,TUL and UL approval.UL File No: E126429

ELECTRICAL

* RATED VOLTAGE : 250VAC

* RATED CURRENT : 2A

* INTERRUPTING CURRENT : 250VAC, 3A

* TRANSIENT OVERLOAD TEST CURRENT : dc current pulses, with an amplitude 30 A and a duration of 3 ms with 10 s intervals, are applied for 100 successive cycles through the current path.

EXPLANATION OF RATINGS

A. RATED FUNCTIONING TEMPERATURE (TF, Tf)

The temperature at which a thermal cutoff changes its state of conductivity to open circuit with detection current as the only load. The tolerance according to UL 1020 is +0, -10 °C.

B. HOLDING TEMPERATURE (TH, Tc)

The maximum temperature at which a thermal cutoff can be maintained while conducting rated current for 168 hours which will not cause a change in the state of conductivity to open circuit.

C. RATED CURRENT

The maximum current which the thermal cutoff is able to carry for a specified time at Tc without alteration of its Functioning Temperature.

D. INTERRUPTING CURRENT

The value of the current that the thermal cutoff is capable of interrupting safely at rated voltage and under specified circuit conditions.

E. TRANSIENT OVERLOAD CURRENT

A direct-current pulse train which the thermal cutoff is able to withstand without impairing its characteristics.

DIMENSIONS

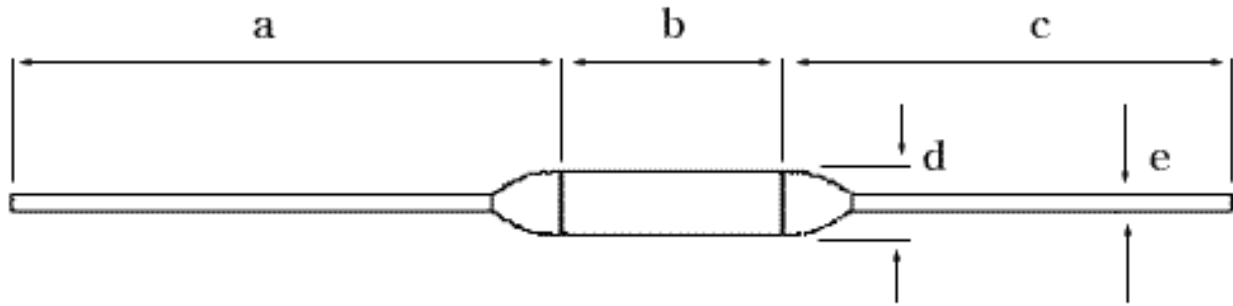

Dimension	a	b	c	d	e
mm	67.0±2.5	9.5±0.5	67.0±2.5	2.5±0.2	0.6±0.05