



PEM® through hole threaded and unthreaded standoffs for mounting, spacing or stacking panels.



**SO™**

**SELF-CLINCHING  
STANDOFFS**

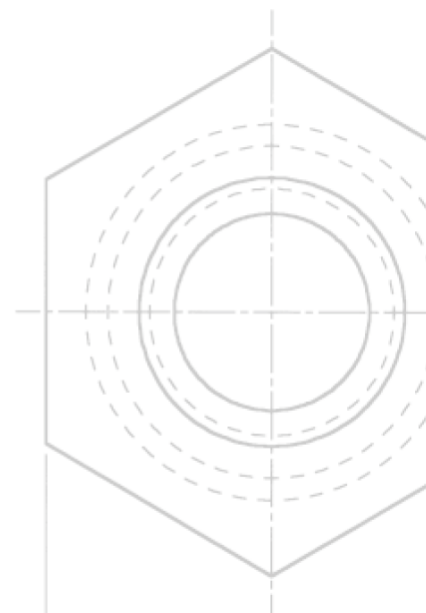
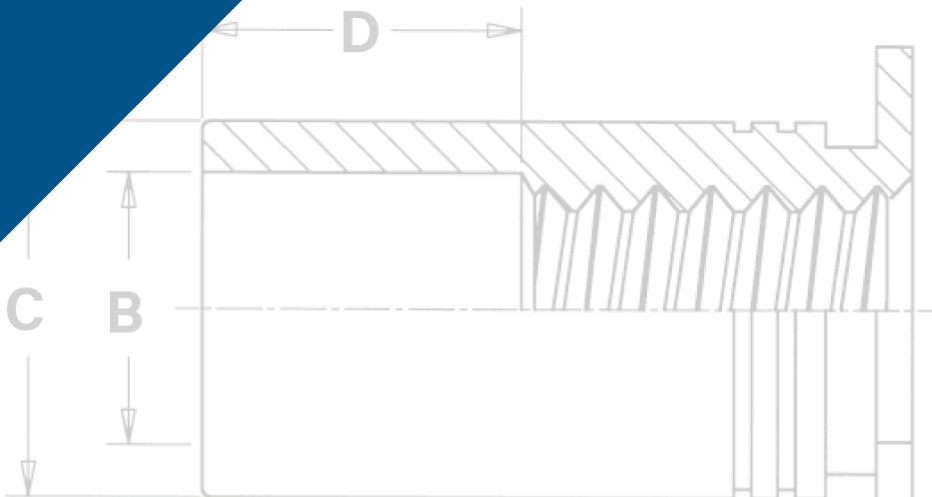

# SELF-CLINCHING STANDOFFS

PEM® self-clinching standoffs, which use the proven self-clinching design, provide ideal solutions for applications where mounting, spacing or stacking of panels, boards or components are required. Pressed into round holes, these fasteners mount permanently into metal sheets as thin as .025" / 0.63 mm.

Specially designed SO4™, BSO4™ and TSO4™ standoffs are made from hardened stainless steel and are ideal for clinching into stainless steel sheets. An optional nickel plating is now available if product is expected to be used in a corrosive environment.

For more information on the proper use of PEM® self-clinching standoffs, check our website for Tech Sheet [PEM® - REF/Standoff Basics](#).

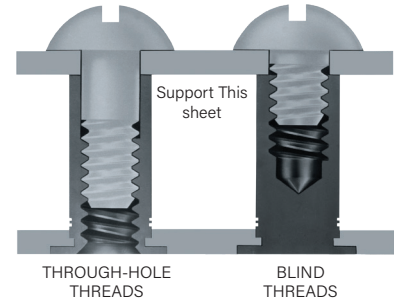

## HEAD SIDE OF SHEET AFTER INSTALLATION

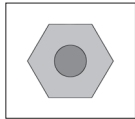

SO/SOS/SOA/SO4  
TSO/TSOS/TSOA/TSO4 (Styles 1 & 2)  
SOSG/SOAG

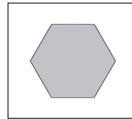

BSO/BSOS/BSOA/BSO4  
TSO/TSOS/TSOA/TSO4 (Style 3)

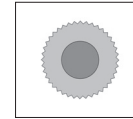

DSOS/DSO

<b>SO™/SOS™/SOA™/SO4™</b> through hole threaded self-clinching standoffs - PAGE 3	
<b>BSO™/BSOS™/BSOA™/BSO4™</b> Blind hole, threaded self-clinching standoffs - PAGE 4	
<b>SO™/SOS™/SOA™/SO4™</b> Through hole, unthreaded self-clinching standoffs - PAGE 5	
<b>TSO™/TSOS™/TSOA™/TSO4™</b> Through hole threaded standoffs for clinching into thinner sheets than SO™ standoffs - PAGE 6	

<b>DSOS™/DSO™</b> Through hole, threaded standoffs with round, knurled head allowing closer-to-edge clinch installation - PAGE 7	
<b>SOSG™/SOAG™</b> Through hole, threaded grounding standoffs with "grounding/earthing teeth" on end of barrel - PAGE 7	
<b>Material and finish specifications - PAGE 8</b>	
<b>Installation - PAGES 8 &amp; 9</b>	
<b>Performance data - PAGES 10 &amp; 11</b>	

PEM® Standoff Type	Application Requires:									
	Installation into stainless steel (1)	Superior corrosion resistance	Threads at barrel end	Closed-end for flush appearance	Grounding/earthing teeth on barrel end	Closest-to-edge distance mounting	Available Unthreaded	Thinnest minimum sheet	Most varied standard length increments	Non-magnetic
BSO			▪	▪						
BSOA			▪	▪						▪
BSOS		▪	▪	▪						▪
BSO4	▪	(2)	▪	▪						
DSO						▪				
DSOS		▪				▪				▪
SO							▪			
SOA							▪			▪
SOS		▪					▪			▪
SO4	▪	(2)					▪			
SOAG					▪					▪
SOSG		▪			▪					▪
TSO			▪	▪ (3)				▪	▪	
TSOA			▪	▪ (3)				▪	▪	▪
TSOS		▪	▪	▪ (3)				▪	▪	▪
TSO4	▪	(2)	▪	▪ (3)				▪	▪	

(1) See note 5 on page 8 about installing fasteners into stainless steel sheets.

(2) When used with optional nickel plating.

(3) Style #3 only.



# SELF-CLINCHING STANDOFFS

## SO™/SOS™/SOA™/SO4™ - THROUGH-HOLE THREADED STANDOFFS

- SO standoffs are recommended for use in steel or aluminum sheets HRB (Rockwell "B" scale) 80 / HB (Hardness Brinell) 150 or less.
- SOS standoffs are recommended for use in steel or aluminum sheets HRB (Rockwell "B" scale) 70 / HB (Hardness Brinell) 125 or less.
- SOA standoffs are recommended for use in aluminum sheets HRB (Rockwell "B" scale) 50 / HB (Hardness Brinell) 82 or less.
- SO4 standoffs are recommended for use in stainless steel sheets HRB (Rockwell "B" scale) 88 / HB (Hardness Brinell) 183 or less.

PEM® "Single" or PEM® "Two Groove" Registered Trademark

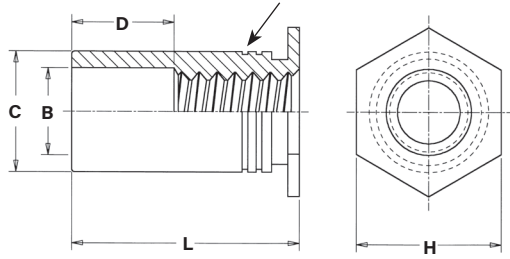

Clinching profile may vary.



SO/SOS/SOA



SO4

Installs into stainless steel

### PART NUMBER DESIGNATION

SO	-	440	-	8	ZI
SO	S	440	-	8	
SO	A	440	-	8	
SO	4	440	-	8	NC*
	↓	↓	↓	↓	↓
Type	Material Code	Thread Code	Length Code	Finish	

### GENERAL DIMENSIONAL DATA

All dimensions are in inches.

UNIFIED	Thread Code	Min. Sheet Thickness	Hole Size In Sheet +.003 -.000	B Counter-Bore Dia. ±.005	C +.000 -.005	H Nom.	Min. Dist. Hole $\varnothing$ To Edge	D $\pm$ .010
	440	.040	.166	.125	.165	.187	.23	Varies according to length. See length charts below.
	6440	.040	.213	.125	.212	.250	.27	
	632	.040	.213	.156	.212	.250	.27	
	8632	.050	.281	.156	.280	.312	.31	
	832	.050	.281	.188	.280	.312	.31	
032	.050	.281	.203	.280	.312	.31		

All dimensions are in millimeters.

METRIC	Thread Code	Min. Sheet Thickness	Hole Size In Sheet +0.08	B Counter-Bore Dia. ±0.13	C -0.13	H Nom.	Min. Dist. Hole $\varnothing$ To Edge	D $\pm$ 0.25
	M3	1	4.22	3.2	4.2	4.8	6	Varies according to length. See length charts below.
	3.5M3	1	5.41	3.2	5.39	6.4	6.8	
	M3.5	1	5.41	3.9	5.39	6.4	6.8	
	M4	1.27	7.14	4.8	7.12	7.9	8	
	M5	1.27	7.14	5.35	7.12	7.9	8	

Micro sizes also available.

See PEM® Bulletin MPF for more information.

\* NC suffix is required if optional nickel plating (for corrosion resistance) is desired. Otherwise, no suffix is necessary.

### THREAD SIZE AND LENGTH SELECTION DATA

All dimensions are in inches.

UNIFIED	Thread Size	Type				Thread Code	Length "L" +.002 -.005 (Length Code in 32nds of an inch)															
		Fastener Material					.125	.187	.250	.312	.375	.437	.500	.562	.625	.687	.750	.812	.875	.937	1.00	1.062
		Steel	Stainless Steel	Aluminum	Hardened Stainless Steel																	
.112-40 (#4-40)	SO	SOS	SOA	SO4	440	4	6	8	10	12	14	16	18	20	22	24	-	-	-	-	-	
					6440 <sup>(1)</sup>	4	6	8	10	12	14	16	18	20	22	24	26	28	30	32	34	
.138-32 (#6-32)	SO	SOS	SOA	SO4	632	4	6	8	10	12	14	16	18	20	22	24	26	28	30	32	34	
					8632 <sup>(1)</sup>	4	6	8	10	12	14	16	18	20	22	24	26	28	30	32	34	
.164-32 (#8-32)	SO	SOS	SOA	SO4	832	4	6	8	10	12	14	16	18	20	22	24	26	28	30	32	34	
.190-32 (#10-32)	SO	SOS	SOA	SO4	032	4	6	8	10	12	14	16	18	20	22	24	26	28	30	32	34	
D Dimension $\pm$ .010						None		.187				.312				.437						

All dimensions are in millimeters.

METRIC	Thread Size x Pitch	Type				Thread Code	Length "L" +0.05 -0.13 (Length Code in millimeters)													
		Fastener Material					M3	3	4	6	8	10	12	14	16	18	20	22	25	
		Steel	Stainless Steel	Aluminum	Hardened Stainless Steel															
M3 x 0.5	SO	SOS	SOA	SO4	M3	3	4	6	8	10	12	14	16	18	-	-	-			
					3.5M3 <sup>(1)</sup>	3	4	6	8	10	12	14	16	18	20	22	25			
M3.5 x 0.6	SO	SOS	SOA	SO4	M3.5	3	4	6	8	10	12	14	16	18	20	22	25			
M4 x 0.7	SO	SOS	SOA	SO4	M4	3	4	6	8	10	12	14	16	18	20	22	25			
M5 x 0.8	SO	SOS	SOA	SO4	M5	3	4	6	8	10	12	14	16	18	20	22	25			
D Dimension $\pm$ 0.25						None				4				8		11				

(1) Standoffs with thread codes 6440, 8632, and 3.5M3 have a thicker wall to provide more bearing surface for the mating component or panel reducing the chance of cracking or cutting into the board.

Please contact your local PEM® distributor for availability, minimum quantity, and pricing information.



# SELF-CLINCHING STANDOFFS

## BSO™/BSOS™/BSOA™/BSO4™ - BLIND THREADED STANDOFFS

- BSO standoffs are recommended for use in steel or aluminum sheets HRB (Rockwell "B" scale) 80 / HB (Hardness Brinell) 150 or less.
- BSOS standoffs are recommended for use in steel or aluminum sheets HRB (Rockwell "B" scale) 70 / HB (Hardness Brinell) 125 or less.
- BSOA standoffs are recommended for use in aluminum sheets HRB (Rockwell "B" scale) 50 / HB (Hardness Brinell) 82 or less.
- BSO4 standoffs are recommended for use in stainless steel sheets HRB (Rockwell "B" scale) 88 / HB (Hardness Brinell) 183 or less.

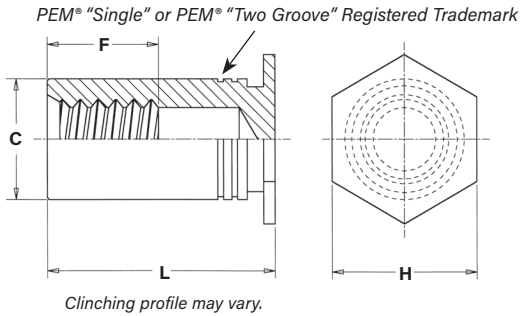

### GENERAL DIMENSIONAL DATA

All dimensions are in inches.

UNIFIED	Thread Code	Min. Sheet Thickness	Hole Size In Sheet +.003 -.000	C +.000 -.005	H Nom.	Min. Dist. Hole $\varnothing$ To Edge	F Min.
	440	.040	.166	.165	.187	.23	Varies according to length. See length charts below.
	6440	.040	.213	.212	.250	.27	
	632	.040	.213	.212	.250	.27	
	8632	.050	.281	.280	.312	.31	
	832	.050	.281	.280	.312	.31	
	032	.050	.281	.280	.312	.31	



### PART NUMBER DESIGNATION

<b>BSO</b>	-	<b>440</b>	-	<b>12</b>	<b>ZI</b>
<b>BSOS</b>	<b>S</b>	-	<b>440</b>	-	<b>12</b>
<b>BSOA</b>	<b>A</b>	-	<b>440</b>	-	<b>12</b>
<b>BSO</b>	<b>4</b>	-	<b>440</b>	-	<b>12</b>
					<b>NC*</b>
Type	Material Code	Thread Code	Length Code	Finish	

All dimensions are in millimeters.

METRIC	Thread Code	Min. Sheet Thickness	Hole Size In Sheet +0.08	C -0.13	H Nom.	Min. Dist. Hole $\varnothing$ To Edge	F Min.
	M3	1	4.22	4.2	4.8	6	Varies according to length. See length charts below.
	3.5M3	1	5.41	5.39	6.4	6.8	
	M3.5	1	5.41	5.39	6.4	6.8	
	M4	1.27	7.14	7.12	7.9	8	
	M5	1.27	7.14	7.12	7.9	8	

Installs into stainless steel

\* NC suffix is required if optional nickel plating (for corrosion resistance) is desired. Otherwise, no suffix is necessary.

### THREAD SIZE AND LENGTH SELECTION DATA

All dimensions are in inches.

UNIFIED	Thread Size	Type				Thread Code	Length "L" +.002 -.005 (Length Code in 32nds of an inch)											
		Steel	Stainless Steel	Aluminum	Hardened Stainless Steel		.312	.375	.437	.500	.562	.625	.687	.750	.812	.875	.937	1.00
	.112-40 (#4-40)	BSO	BSOS	BSOA	BSO4	440 6440 <sup>(1)</sup>	10	12	14	16	18	20	22	24	26	28	30	32
.138-32 (#6-32)	BSO	BSOS	BSOA	BSO4	632 8632 <sup>(1)</sup>	10	12	14	16	18	20	22	24	26	28	30	32	34
.164-32 (#8-32)	BSO	BSOS	BSOA	BSO4	832	10	12	14	16	18	20	22	24	26	28	30	32	34
.190-32 (#10-32)	BSO	BSOS	BSOA	BSO4	032	10	12	14	16	18	20	22	24	26	28	30	32	34
<b>F Dimension Min.</b>							.156	.187	.250			.375						

All dimensions are in millimeters.

METRIC	Thread Size x Pitch	Type				Thread Code	Length "L" +0.05 -0.13 (Length Code in millimeters)									
		Steel	Stainless Steel	Aluminum	Hardened Stainless Steel		6	8	10	12	14	16	18	20	22	25
	M3 x 0.5	BSO	BSOS	BSOA	BSO4	M3 3.5M3 <sup>(1)</sup>	6	8	10	12	14	16	18	20	22	25
M3.5 x 0.6	BSO	BSOS	BSOA	BSO4	M3.5	6	8	10	12	14	16	18	20	22	25	
M4 x 0.7	BSO	BSOS	BSOA	BSO4	M4	6	8	10	12	14	16	18	20	22	25	
M5 x 0.8	BSO	BSOS	BSOA	BSO4	M5	6	8	10	12	14	16	18	20	22	25	
<b>F Dimension Min.</b>						3.2	4		5	6.5			9.5			

(1) Standoffs with thread codes 6440, 8632, and 3.5M3 have a thicker wall to provide more bearing surface for the mating component or panel reducing the chance of cracking or cutting into the board.

Please contact your local PEM® distributor for availability, minimum quantity, and pricing information.



# SELF-CLINCHING STANDOFFS

## SO™/SOS™/SOA™/SO4™ - THROUGH-HOLE UNTHREADED STANDOFFS (SPECIAL ORDER)

- SO standoffs are recommended for use in steel or aluminum sheets HRB (Rockwell "B" scale) 80 / HB (Hardness Brinell) 150 or less.
- SOS standoffs are recommended for use in steel or aluminum sheets HRB (Rockwell "B" scale) 70 / HB (Hardness Brinell) 125 or less.
- SOA standoffs are recommended for use in aluminum sheets HRB (Rockwell "B" scale) 50 / HB (Hardness Brinell) 82 or less.
- SO4 standoffs are recommended for use in stainless steel sheets HRB (Rockwell "B" scale) 88 / HB (Hardness Brinell) 183 or less.

PEM® "Single" or PEM® "Two Groove" Registered Trademark

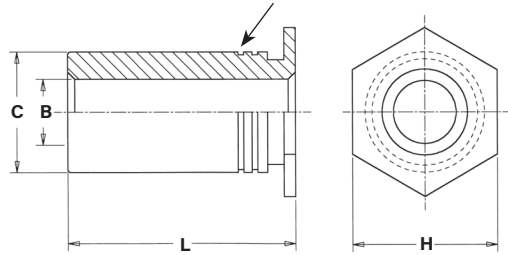

Clinching profile may vary.



SO/SOS/SOA



SO4

Installs into stainless steel

### PART NUMBER DESIGNATION

SO	-	4116	-	8	ZI
SO	S	4116	-	8	
SO	A	4116	-	8	
SO	4	4116	-	8	NC*
↓	↓	↓	↓	↓	↓
Type	Material Code	Thru-hole Code	Length Code	Finish	

### GENERAL DIMENSIONAL DATA

All dimensions are in inches.

UNIFIED	Thru-hole Code	Min. Sheet Thickness	Hole Size In Sheet +0.003 -0.000	C +0.000 -0.005	H Nom.	Min. Dist. Hole To Edge
	4116	.040	.166	.165	.187	.23
	6116	.040	.213	.212	.250	.27
	6143	.040	.213	.212	.250	.27
	8143	.050	.281	.280	.312	.31
	8169	.050	.281	.280	.312	.31
	8194	.050	.281	.280	.312	.31

All dimensions are in millimeters.

METRIC	Thru-hole Code	Min. Sheet Thickness	Hole Size In Sheet +0.08	C -0.13	H Nom.	Min. Dist. Hole To Edge
	43.1	1	4.22	4.2	4.8	6
	63.1	1	5.41	5.39	6.4	6.8
	63.6	1	5.41	5.39	6.4	6.8
	83.6	1.27	7.14	7.12	7.9	8
	84.1	1.27	7.14	7.12	7.9	8
	85.1	1.27	7.14	7.12	7.9	8

Micro sizes also available.

See PEM® [Bulletin MPF](#) for more information.

### THROUGH-HOLE AND LENGTH SELECTION DATA

All dimensions are in inches.

UNIFIED	B Thru-hole Diameter +0.04 -0.03	Type				Thru-hole Code	Length "L" +0.002 -0.005 (Length Code in 32nds of an inch)										
		Steel	Stainless Steel	Aluminum	Hardened Stainless Steel		.125	.187	.250	.312	.375	.437	.500	.562	.625	.687	.750
		.116	SO	SOS	SOA		SO4	4116 6116 <sup>(1)</sup>	4	6	8	10	12	14	16	18	20
.143	SO	SOS	SOA	SO4	6143 8143 <sup>(1)</sup>	4	6	8	10	12	14	16	18	20	22	24	
.169	SO	SOS	SOA	SO4	8169	4	6	8	10	12	14	16	18	20	22	24	
.194	SO	SOS	SOA	SO4	8194	4	6	8	10	12	14	16	18	20	22	24	

All dimensions are in millimeters.

METRIC	B Thru-hole Diameter +0.1 -0.08	Type				Thru-hole Code	Length "L" +0.05 -0.13 (Length Code in millimeters)									
		Steel	Stainless Steel	Aluminum	Hardened Stainless Steel		3	4	6	8	10	12	14	16	18	20
		3.1	SO	SOS	SOA		SO4	43.1 63.1 <sup>(1)</sup>	3	4	6	8	10	12	14	16
3.6	SO	SOS	SOA	SO4	63.6 83.6 <sup>(1)</sup>	3	4	6	8	10	12	14	16	18	20	
4.1	SO	SOS	SOA	SO4	84.1	3	4	6	8	10	12	14	16	18	20	
5.1	SO	SOS	SOA	SO4	85.1	3	4	6	8	10	12	14	16	18	20	

(1) Standoffs with thru-hole codes 6116, 8143, 63.1 and 83.6 have a thicker wall to provide more bearing surface for the mating component or panel reducing the chance of cracking or cutting into the board.

Please contact your local PEM® distributor for availability, minimum quantity, and pricing information.



# SELF-CLINCHING STANDOFFS

## TSO™/TSOS™/TSOA™/TSO4™ THREADED STANDOFFS FOR SHEETS AS THIN AS .025"/0.63mm

- TSO standoffs are recommended for use in steel or aluminum sheets HRB (Rockwell "B" scale) 60 / HB (Hardness Brinell) 150 or less.
- TSOS standoffs are recommended for use in steel or aluminum sheets HRB (Rockwell "B" scale) 70 / HB (Hardness Brinell) 125 or less.
- TSOA standoffs are recommended for use in aluminum sheets HRB (Rockwell "B" scale) 50 / HB (Hardness Brinell) 82 or less.
- TSO4 standoffs are recommended for use in stainless steel sheets HRB (Rockwell "B" scale) 88 / HB (Hardness Brinell) 183 or less.

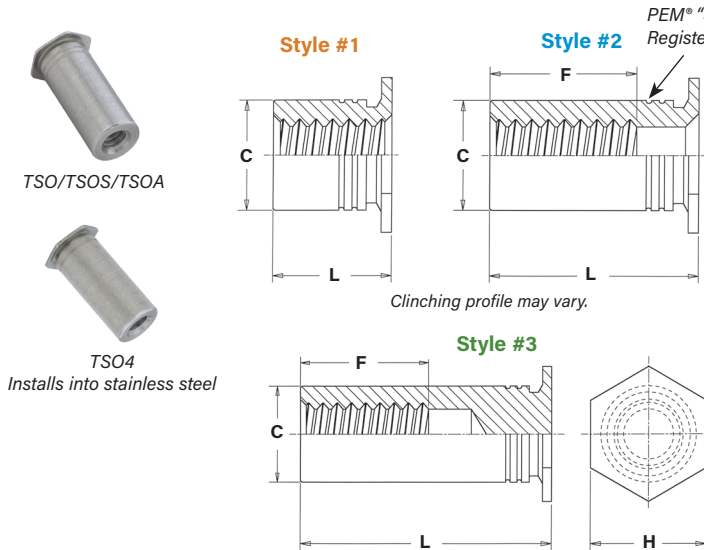

### GENERAL DIMENSIONAL DATA

All dimensions are in inches.

UNIFIED	Thread Code	Min. Sheet Thickness	Hole Size In Sheet +.003 -.000	C +.000 -.005	F Min. Thread Depth	H Nom.	Min. Dist. Hole To Edge
	256	.025	.166	.165	.200	.187	.23
	6256	.025	.213	.212		.250	.27
	440	.025	.166	.165	.220	.187	.23
	6440	.025	.213	.212		.250	.27
632	.025	.213	.212	.270	.250	.27	

All dimensions are in millimeters.

METRIC	Thread Code	Min. Sheet Thickness	Hole Size In Sheet +0.08	C -0.13	F Min. Thread Depth	H Nom.	Min. Dist. Hole To Edge
	M25	0.63	4.22	4.2	5.2	4.8	5.8
	6M25	0.63	5.41	5.39		6.4	7.1
	M3	0.63	4.22	4.2	6.2	4.8	5.8
	6M3	0.63	5.41	5.39		6.4	7.1
M35	0.63	5.41	5.39	7	6.4	7.1	

### THREAD SIZE AND LENGTH SELECTION DATA

All dimensions are in inches.

UNIFIED	Thread Size	Type				Thread Code	Length "L" ±.003										
		Steel	Stainless Steel	Aluminum	Hardened Stainless Steel		For other lengths / thread depth data see chart at bottom of page.										
		Length Code (Length "L" without decimal point)															
		.090	.125	.187	.250		.312	.375	.437	.500	.562	.625	.687	.750			
.086-56 (#2-56)	TSO	TSOS	TSOA	TSO4	256	090 <sup>(1)</sup>	125 <sup>(1)</sup>	187 <sup>(1)</sup>	250 <sup>(1)</sup>	312 <sup>(2)</sup>	375 <sup>(2)</sup>	437 <sup>(3)</sup>	500 <sup>(3)</sup>	562 <sup>(3)</sup>	625 <sup>(3)</sup>	687 <sup>(3)</sup>	750 <sup>(3)</sup>
					6256 <sup>(4)</sup>												
.112-40 (#4-40)	TSO	TSOS	TSOA	TSO4	440	090 <sup>(1)</sup>	125 <sup>(1)</sup>	187 <sup>(1)</sup>	250 <sup>(1)</sup>	312 <sup>(2)</sup>	375 <sup>(2)</sup>	437 <sup>(2)</sup>	500 <sup>(3)</sup>	562 <sup>(3)</sup>	625 <sup>(3)</sup>	687 <sup>(3)</sup>	750 <sup>(3)</sup>
					6440 <sup>(4)</sup>												
.138-32 (#6-32)	TSO	TSOS	TSOA	TSO4	632	-	125 <sup>(1)</sup>	187 <sup>(1)</sup>	250 <sup>(1)</sup>	312 <sup>(1)</sup>	375 <sup>(2)</sup>	437 <sup>(2)</sup>	500 <sup>(2)</sup>	562 <sup>(3)</sup>	625 <sup>(3)</sup>	687 <sup>(3)</sup>	750 <sup>(3)</sup>

All dimensions are in millimeters.

METRIC	Thread Size x Pitch	Type				Thread Code	Length "L" ±0.08										
		Steel	Stainless Steel	Aluminum	Hardened Stainless Steel		For other lengths / thread depth data see chart at bottom of page.										
		Length Code (Length "L" without decimal point)															
		2.00	3.00	4.00	6.00		8.00	10.00	12.00	14.00	16.00	18.00	19.00				
M2.5 x 0.45	TSO	TSOS	TSOA	TSO4	M25	200 <sup>(1)</sup>	300 <sup>(1)</sup>	400 <sup>(1)</sup>	600 <sup>(1)</sup>	800 <sup>(2)</sup>	1000 <sup>(3)</sup>	1200 <sup>(3)</sup>	1400 <sup>(3)</sup>	1600 <sup>(3)</sup>	1800 <sup>(3)</sup>	1900 <sup>(3)</sup>	
					6M25 <sup>(4)</sup>												
M3 x 0.5	TSO	TSOS	TSOA	TSO4	M3	200 <sup>(1)</sup>	300 <sup>(1)</sup>	400 <sup>(1)</sup>	600 <sup>(1)</sup>	800 <sup>(2)</sup>	1000 <sup>(2)</sup>	1200 <sup>(3)</sup>	1400 <sup>(3)</sup>	1600 <sup>(3)</sup>	1800 <sup>(3)</sup>	1900 <sup>(3)</sup>	
					6M3 <sup>(4)</sup>												
M3.5 x 0.6	TSO	TSOS	TSOA	TSO4	M35	-	300 <sup>(1)</sup>	400 <sup>(1)</sup>	600 <sup>(1)</sup>	800 <sup>(1)</sup>	1000 <sup>(2)</sup>	1200 <sup>(2)</sup>	1400 <sup>(3)</sup>	1600 <sup>(3)</sup>	1800 <sup>(3)</sup>	1900 <sup>(3)</sup>	

(1) Style #1. Thru-threaded.

(2) Style #2. Screw might not pass through unthreaded end. Tapped to minimum full thread depth shown. Incomplete threads on tap may allow screw to pass through.

(3) Style #3. Blind.

(4) Standoffs with thread codes 6256, 6440, 6M25 and 6M3 have a thicker wall to provide more bearing surface for the mating component or panel reducing the chance of cracking or cutting into the board.

Please contact your local PEM® distributor for availability, minimum quantity, and pricing information.

### LENGTH/STYLE DATA

All dimensions are in inches.

(Length can be specified in .001" increments.)

UNIFIED	Thread Code	Length "L" (Style #1)	Length "L" (Style #2)	Length "L" (Style #3)
	256 / 6256	.090 - .250	.251 - .375	.376 - .750
	440 / 6440	.090 - .280	.281 - .450	.451 - .750
	632	.120 - .350	.351 - .540	.541 - .750

All dimensions are in millimeters.

(Length can be specified in 0.02 mm increments.)

METRIC	Thread Code	Length "L" (Style #1)	Length "L" (Style #2)	Length "L" (Style #3)
	M25 / 6M25	2.00 - 6.30	6.32 - 9.50	9.52 - 19.00
	M3 / 6M3	2.00 - 7.50	7.52 - 11.00	11.02 - 19.00
	M35	3.00 - 8.80	8.82 - 12.80	12.82 - 19.00

### PART NUMBER DESIGNATION

TSO - 440 - 250 ZI  
 TSO S - 440 - 250  
 TSO A - 440 - 250  
 TSO 4 - 440 - 250 NC\*

Type Material Code Thread Code Length Code Finish

\* NC suffix is required if optional nickel plating (for corrosion resistance) is desired. Otherwise, no suffix is necessary.



# SELF-CLINCHING STANDOFFS

## DSOS™/DSO™ THREADED STANDOFFS - FOR CLOSE-TO-EDGE APPLICATIONS

- DSO standoffs are recommended for use in steel or aluminum sheets HRB (Rockwell "B" scale) 80 / HB (Hardness Brinell) 150 or less.
- DSOS standoffs are recommended for use in steel or aluminum sheets HRB (Rockwell "B" scale) 70 / HB (Hardness Brinell) 125 or less.



### PART NUMBER DESIGNATION

**DSO**    **S** - **440** - **250**  
**DSO**    - **440** - **250**    **ZI**  
 ↓        ↓        ↓        ↓        ↓  
 Type    Material    Thread    Length    Finish  
       Code        Code        Code        Code

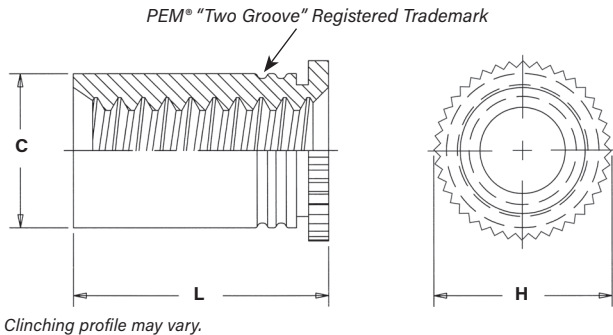

All dimensions are in inches.

UNIFIED	Thread Size	Type		Thread Code	Length Code	Sheet Thickness	Hole Size In Sheet +.003 -.000	C Max.	H Nom.	L <sup>(1)</sup> +.002 -.005	Min. Dist. Hole To Edge
		Stainless Steel	Steel								
	.112-40 (#4-40)	DSOS	DSO	440	250	.037 - .250	.166	.165	.194	.250	.126
					275					.275	

All dimensions are in millimeters.

METRIC	Thread Size x Pitch	Type		Thread Code	Length Code	Sheet Thickness	Hole Size In Sheet +0.08	C Max.	H Nom.	L <sup>(1)</sup> +0.05 -0.13	Min. Dist. Hole To Edge
		Stainless Steel	Steel								
	M3 x 0.5	DSOS	DSO	M3	6.35	0.94 - 6.35	4.22	4.2	4.92	6.35	3.2
					7					7	

(1) Available in other lengths on special order.

Please contact your local PEM® distributor for availability, minimum quantity, and pricing information.

## SOSG™/SOAG™ GROUNDING/EARTHING STANDOFFS

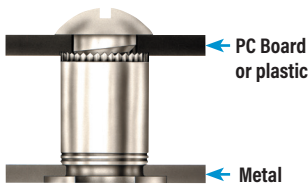

### PART NUMBER DESIGNATION

**SO**    **S**    **G** - **6440** - **10**  
**SO**    **A**    **G** - **6440** - **10**  
 ↓        ↓        ↓        ↓        ↓  
 Type    Material    Grounding/    Thread    Length  
       Code        Code    Earthing    Code        Code

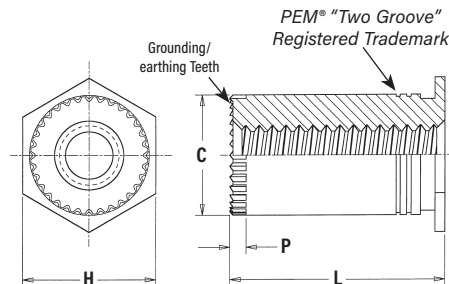

All dimensions are in inches.

UNIFIED	Thread Size	Type		Thread Code	Length "L" +.010 -.000 (Length Code is in 32nds of an inch)						Min. Sheet Thickness	Hole Size In Sheet +.003 -.000	C +.000 -.005	H ±.005	P Nom.	Min. Dist. Hole To Edge	
		Stainless Steel	Aluminum		.125	.187	.250	.312	.375	.437							.500
	.112-40 (#4-40)	SOSG	SOAG	6440	4	6	8	10	12	14	16	.040	.213	.212	.250	.030	.27
					4	6	8	10	12	14	16						
	.138-32 (#6-32)	SOSG	SOAG	8632	4	6	8	10	12	14	16	.050	.281	.280	.312	.030	.31
					4	6	8	10	12	14	16						

All dimensions are in millimeters.

METRIC	Thread Size x Pitch	Type		Thread Code	Length "L" +0.25 (Length Code is in millimeters)						Min. Sheet Thickness	Hole Size In Sheet +0.08	C -0.13	H ±0.25	P Nom.	Min. Dist. Hole To Edge
		Stainless Steel	Aluminum		3	4	6	8	10	12						
	M3 x 0.5	SOSG	SOAG	3.5M3	3	4	6	8	10	12	1	5.4	5.39	6.4	0.76	6.8



# SELF-CLINCHING STANDOFFS

## MATERIAL AND FINISH SPECIFICATIONS

Type	Threads <sup>(1)</sup>	Fastener Materials					Standard Finishes			Optional Finish	For Use In Sheet Hardness: <sup>(4)</sup>				
	Internal, ASME B1.1, 2B ASME B1.13M, 6H	Hardened Carbon Steel	Non-heat Treated Carbon Steel	Aluminum	300 Series Stainless Steel	Hardened 400 Series Stainless Steel (5)	Zinc Plated per ASTM B633, SCl (5µm), Type III Colorless (2)	Passivated and/or Tested Per ASTM A380	No Finish	Electroless Nickel over Copper over Nickel Strike Per ASTM B733 (2) (3)	HRB 88 / HB 183 or Less	HRB 80 / HB 150 or Less	HRB 70 / HB 125 or Less	HRB 60 / HB 107 or Less	HRB 50 / HB 89 or Less
SO	■	■					■					■			
SOA	■			■					■						■
SOS	■				■				■			■			
SO4	■					■			■		■				
BSO	■	■					■					■			
BSOA	■			■					■						■
BSOS	■				■				■			■			
BSO4	■					■			■		■				
TSO	■		■				■						■		
TSOS	■				■				■			■			
TSOA	■			■					■						■
TSO4	■					■			■		■				
DSO	■	■					■					■			
DSOS	■				■				■			■			
SOAG	■			■					■						■
SOSG	■				■				■			■			
Part Number Codes For Finishes							ZI	None	None	NC					

- (1) Where applicable.
- (2) See PEM Technical Support section of our website for related plating standards and specifications.
- (3) Not stocked, available on special order. Minimum quantities apply. Contact your local PEM® distributor for details.
- (4) HRB - Hardness Rockwell "B" Scale. HB - Hardness Brinell.
- (5) In order for self-clinching fasteners to work properly, the fastener must be harder than the sheet into which it is being installed (For more information, see our [tech sheet](#) for installing fasteners into stainless steel sheets). In the case of stainless steel panels, fasteners made from 300 Series Stainless Steel do not meet this hardness criteria. It is for this reason that SO4™, BSO4™ and TSO4™ 400 series fasteners are offered. However, while these 400 Series fasteners install and perform well in 300 Series stainless sheets they should not be used if the end product will be exposed to any appreciable corrosive environment (unless finished with optional nickel plating), requires non-magnetic fasteners or will be exposed to any temperatures above 300°F (149°C). If any of these are issues, please contact [techsupport@pemnet.com](mailto:techsupport@pemnet.com) for other options.

## INSTALLATION

### SO™/SOS™/SOA™/SO4™/BSO™/BSOS™/BSOA™/BSO4™ STANDOFFS

1. Prepare properly sized mounting hole in sheet. Do not perform any secondary operation such as deburring.
2. Insert standoff through mounting hole (preferably the punch side) of sheet and into anvil as shown in drawing.
3. With installation punch and anvil surfaces parallel, apply only enough squeezing force to embed the standoff's head flush in the sheet. Drawing at right shows suggested tooling for applying these forces.

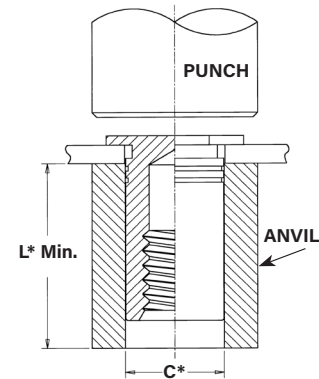

\*See pages 3 & 4 for "C" and "L"

+0.004" to +0.007" / +0.1 mm to +0.18 mm

### PEMSERTER® Installation Tooling

Thread Code	Anvil Part Number	Punch Part Number
440/M2/M2.5/M3	970200487300	975200048
632/6440/3.5M3/M3.5	970200012300	
832/8632/M4	970200013300	
032/M5	970200013300	
0420/M6	970200393300	





# SELF-CLINCHING STANDOFFS

## INSTALLATION

### TSO™/TSOS™/TSOA™/TSO4™ STANDOFFS

1. Prepare properly sized mounting hole in sheet. Do not perform any secondary operation such as deburring.
2. Insert standoff through mounting hole (preferably the punch side) of sheet and into anvil as shown in drawing.
3. With installation punch and anvil surfaces parallel, apply only enough squeezing force to embed the standoff's head flush in the sheet. Drawing at right shows required installation anvil for sheet thickness of .025" to .032" / 0.63 mm to 0.81 mm. A chamfered anvil is not required for sheets over .032" / 0.81 mm.

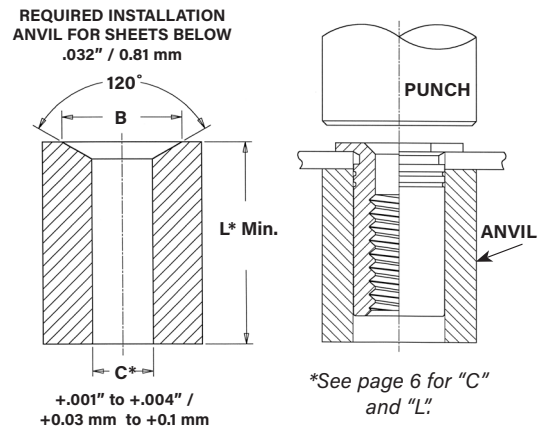

### PEMSERTER® Installation Tooling

UNIFIED	Thread Code	Anvil Dimensions (in.) For Sheets Below .032"		Anvil Part No. For Sheets Over .032"	Punch Part Number
		B	Anvil Part No.		
	256/440	.187 - .194	8003291	970200487300	975200048
	6256/6440/632	.250 - .257	8003292	970200012300	975200048

METRIC	Thread Code	Anvil Dimensions (mm) For Sheets Below 0.81 mm		Anvil Part No. For Sheets Over 0.81 mm	Punch Part Number
		B	Anvil Part No.		
	M2.5/M3	4.75 - 4.93	8003291	970200487300	975200048
	6M25/6M3/M35	6.35 - 6.53	8003292	970200012300	975200048

### DSOS™/DSO™ STANDOFFS

1. Prepare properly sized mounting hole in sheet. Do not perform any secondary operations such as deburring.
2. Insert fastener through mounting hole (preferably the punch side) and into anvil as shown in drawing.
3. With installation punch and anvil surfaces parallel, apply only enough squeezing force to embed the standoff's head flush in the sheet.

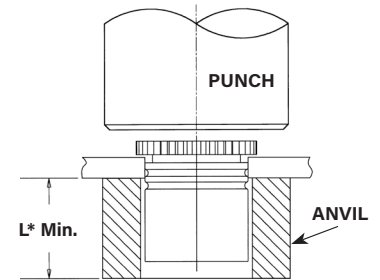

### PEMSERTER® Installation Tooling

Thread Code	Anvil Part Number	Punch Part Number
440/M3	970200487300	975200048
6440/3.5M3	970200012300	
8632	970200013300	

\*See page 7 for "C" and "L".

+0.004" to +0.007" / +0.1 mm to +0.18 mm

### SOSG™/SOAG™ STANDOFFS

1. Prepare properly sized mounting hole in sheet. Do not perform any secondary operations such as deburring.
2. Insert fastener through mounting hole (preferably the punch side) and into anvil as shown in drawing.
3. With installation punch and anvil surfaces parallel, apply only enough squeezing force to embed the standoff's head flush in the sheet.

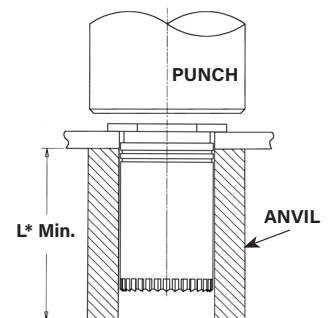

\*See page 7 for "D" and "L".

+0.004" to +0.007" / +0.1 mm to +0.18 mm

### PEMSERTER® Installation Tooling

Thread Code	Anvil Part Number	Punch Part Number
440/M3	970200487300	975200048
6440/3.5M3	970200012300	
8632	970200013300	

### INSTALLATION NOTES

- For best results we recommend using a Haeger® or PEMSERTER® press for installation of PEM® standoffs. Please check our website for more information.
- Visit the Animation Library on our website to view the installation process [for this product](#).



# SELF-CLINCHING STANDOFFS

## PERFORMANCE DATA<sup>(1)</sup>

### SO™/SOS™/SOA™/BSO™/BSOS™/BSOA™ STANDOFFS

UNIFIED	Thread Code	Standoff Material	Max. Rec. Tightening Torque For Mating Screw (in. lbs.)	Test Sheet Material							
				.060" 5052-H34 Aluminum				.060" Cold-rolled Steel			
				Installation (lbs.)	Pushout (lbs.)	Torque-out (in. lbs.) (2)	Pull-thru (lbs.) (2)	Installation (lbs.)	Pushout (lbs.)	Torque-out (in. lbs.) (2)	Pull-thru (lbs.) (2)
440	Steel	4.75	1100	160	11	280	2200	225	19	330	
	Stainless Steel	3.8	1100	160	11	224	2200	225	19	264	
	Aluminum	2.85	1100	160	11	168	-	-	-	-	
6440	Steel	4.75	1700	300	25	310	3300	420	35	380	
	Stainless Steel	3.8	1700	300	25	248	3300	420	35	304	
	Aluminum	2.85	1700	300	25	186	-	-	-	-	
632	Steel	8.75	1700	300	25	310	3300	420	35	380	
	Stainless Steel	7	1700	300	25	248	3300	420	35	304	
	Aluminum	5.25	1700	300	25	186	-	-	-	-	
8632	Steel	8.75	2400	400	45	580	4000	560	75	700	
	Stainless Steel	7	2400	400	45	464	4000	560	75	560	
	Aluminum	5.25	2400	400	45	248	-	-	-	-	
832	Steel	18	2400	400	45	580	4000	560	75	700	
	Stainless Steel	14.4	2400	400	45	464	4000	560	75	560	
	Aluminum	11	2400	400	45	348	-	-	-	-	
032	Steel	32	2400	400	45	580	4000	560	75	700	
	Stainless Steel	25.6	2400	400	45	464	4000	560	75	560	
	Aluminum	19	2400	400	45	348	-	-	-	-	

METRIC	Thread Code	Standoff Material	Max. Rec. Tightening Torque For Mating Screw (N-m)	Test Sheet Material							
				1.5 mm 5052-H34 Aluminum				1.5 mm Cold-rolled Steel			
				Installation (kN)	Pushout (N)	Torque-out (N-m) (2)	Pull-thru (N) (2)	Installation (kN)	Pushout (N)	Torque-out (N-m) (2)	Pull-thru (N) (2)
M3	Steel	0.55	4.9	710	1.24	1245	9.8	1000	2.15	1465	
	Stainless Steel	0.44	4.9	710	1.24	996	9.8	1000	2.15	1172	
	Aluminum	0.33	4.9	710	1.24	747	-	-	-	-	
3.5M3	Steel	0.55	7.6	1330	2.82	1375	14.7	1860	3.95	1690	
	Stainless Steel	0.44	7.6	1330	2.82	1100	14.7	1860	3.95	1352	
	Aluminum	0.33	7.6	1330	2.82	825	-	-	-	-	
M3.5	Steel	0.91	7.6	1330	2.82	1375	14.7	1860	3.95	1690	
	Stainless Steel	0.73	7.6	1330	2.82	1100	14.7	1860	3.95	1352	
	Aluminum	0.55	7.6	1330	2.82	825	-	-	-	-	
M4	Steel	2	10.7	1780	5.08	2575	17.8	2490	8.47	3110	
	Stainless Steel	1.6	10.7	1780	5.08	2060	17.8	2490	8.47	2488	
	Aluminum	1.2	10.7	1780	5.08	1545	-	-	-	-	
M5	Steel	3.6	10.7	1780	5.08	2575	17.8	2490	8.47	3110	
	Stainless Steel	2.88	10.7	1780	5.08	2060	17.8	2490	8.47	2488	
	Aluminum	2.16	10.7	1780	5.08	1545	-	-	-	-	

### SO4™/BSO4™ STANDOFFS

UNIFIED	Thread Code	Max. Rec. Tightening Torque For Mating Screw (in. lbs.)	Test Sheet Material			
			.050" 300 Series Stainless Steel			
			Installation (lbs.)	Pushout (lbs.)	Torque-out (in. lbs.) (2)	Pull-thru (lbs.) (2)
440	4.75	5500	336	17	600	
6440	4.75	9500	647	30	680	
632	8.75	9500	647	30	680	
8632	8.75	10500	900	71	1392	
832	18	10500	900	71	1517	
032	32	10500	900	71	1368	

METRIC	Thread Code	Max. Rec. Tightening Torque For Mating Screw (N-m)	Test Sheet Material			
			1.3 mm 300 Series Stainless Steel			
			Installation (kN)	Pushout (N)	Torque-out (N-m) (2)	Pull-thru (N) (2)
M3	0.55	24.5	1493	2.36	2650	
3.5M3	0.55	42.3	2877	3.06	3025	
M3.5	0.91	42.3	2877	3.06	3025	
M4	2	46.7	4003	8.89	6458	
M5	3.6	46.7	4003	8.89	6226	

(1) Published installation forces are for general reference. Actual set-up and confirmation of complete installation should be made by observing proper seating of fastener as described in the installation steps. Other performance values reported are averages when all proper installation parameters and procedures are followed. Variations in mounting hole size, sheet material, and installation procedure may affect performance. Performance testing this product in your application is recommended. We will be happy to provide technical assistance and/or samples for this purpose.

(2) Joint failure in torque-out and pull-thru will depend on the strength and type of screw being used. In some cases the failure will be in the screw and not in the self-clinching standoff. Please contact our Applications Engineering group with any questions.



# SELF-CLINCHING STANDOFFS

## PERFORMANCE DATA<sup>(1)</sup>

### TSO™/TSOS™/TSOA™ STANDOFFS

Standoff "C" Dimension	Standoff Material	Test Sheet Material															
		.025" / 0.64 mm 5052-H34 Aluminum								.025" / 0.64 mm Cold-rolled Steel							
		Installation		Pushout		Torque-out <sup>(2)</sup>		Pull-thru <sup>(2)</sup>		Installation		Pushout		Torque-out <sup>(2)</sup>		Pull-thru <sup>(2)</sup>	
(lbs.)	(kN)	(lbs.)	(N)	(in. lbs.)	(N-m)	(lbs.)	(N)	(lbs.)	(kN)	(lbs.)	(N)	(in. lbs.)	(N-m)	(lbs.)	(N)		
.165" / 4.2 mm	Steel	700	3.1	70	311	6	0.68	230	1022	1100	4.9	100	445	9	1	206	916
	Stainless Steel	700	3.1	70	311	6	0.68	268	1191	1100	4.9	100	445	9	1	260	1155
	Aluminum	700	3.1	70	311	6	0.68	227	1009	—	—	—	—	—	—	—	—
.212" / 5.39 mm	Steel	700	3.1	90	400	11	1.24	264	1173	1800	8	150	667	15	1.7	207	920
	Stainless Steel	700	3.1	90	400	11	1.24	340	1511	1800	8	150	667	15	1.7	344	1529
	Aluminum	700	3.1	90	400	11	1.24	300	1333	—	—	—	—	—	—	—	—

### TSO4™ STANDOFFS

Standoff "C" Dimension	Test Sheet Material							
	.025" / 0.64 mm 300 series stainless steel							
	Installation		Pushout		Torque-out <sup>(2)</sup>		Pull-thru <sup>(2)</sup>	
(lbs.)	(kN)	(lbs.)	(N)	(in. lbs.)	(N-m)	(lbs.)	(N)	
.165" / 4.2 mm	6500	28.9	125	555	13	1.5	414	1840
.212" / 5.39 mm	6800	30.3	160	710	22	2.5	552	2453

### DSOS™/DSO™ STANDOFFS

UNIFIED	Thread Code	Max. Rec. Tightening Torque For Mating Screw (in. lbs.)	Test Sheet Material							
			.040" 5052-H34 Aluminum				.040" Cold-rolled Steel			
			Installation (lbs.)	Pushout (lbs.)	Torque-out (in. lbs.) <sup>(2)</sup>	Pull-thru (lbs.) <sup>(2)</sup>	Installation (lbs.)	Pushout (lbs.)	Torque-out (in. lbs.) <sup>(2)</sup>	Pull-thru (lbs.) <sup>(2)</sup>
440	3.8	700	50	10	320	1100	75	10	357	

METRIC	Thread Code	Max. Rec. Tightening Torque For Mating Screw (N-m)	Test Sheet Material							
			1 mm 5052-H34 Aluminum				1 mm Cold-rolled Steel			
			Installation (kN)	Pushout (N)	Torque-out (N-m) <sup>(2)</sup>	Pull-thru (N) <sup>(2)</sup>	Installation (kN)	Pushout (N)	Torque-out (N-m) <sup>(2)</sup>	Pull-thru (N) <sup>(2)</sup>
M3	0.44	3.1	223	1.1	1422	4.9	334	1.1	1587	

### SOSG™/SOAG™ STANDOFFS

UNIFIED	Thread Code	Test Sheet Thickness and Test Sheet Material	Installation (lbs.)	Pushout (lbs.)	Torque-out (in. lbs.) <sup>(2)</sup>	Pull-thru (lbs.) <sup>(2)</sup>
	6440	.064" 5052-H34 Aluminum	1700	300	25	186
	8632	.064" 5052-H34 Aluminum	1700	400	45	248

METRIC	Thread Code	Test Sheet Thickness and Test Sheet Material	Installation (kN)	Pushout (N)	Torque-out (N-m) <sup>(2)</sup>	Pull-thru (N) <sup>(2)</sup>
	3.5M3	1.6 mm 5052-H34 Aluminum	7.6	1330	2.82	825

(1) Published installation forces are for general reference. Actual set-up and confirmation of complete installation should be made by observing proper seating of fastener as described in the installation steps. Other performance values reported are averages when all proper installation parameters and procedures are followed. Variations in mounting hole size, sheet material, and installation procedure may affect performance. Performance testing this product in your application is recommended. We will be happy to provide technical assistance and/or samples for this purpose.

(2) Joint failure in torque-out and pull-thru will depend on the strength and type of screw being used. In some cases the failure will be in the screw and not in the self-clinching standoff. Please contact our Applications Engineering group with any questions.



# SELF-CLINCHING STANDOFFS

If you require a standoff which we do not offer in this bulletin, please contact us. We will be happy to work with you to satisfy your special need. For other types of standard PEM® brand standoffs and spacers see:

## Bulletin CH

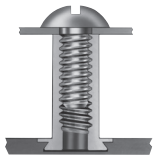

PEM® concealed-head standoffs.

## Bulletin K

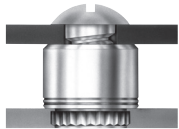

PEM® broaching and surface mount standoffs for printed circuit boards.

## Bulletin SK



PEM® KEYHOLE® standoffs.

## Bulletin SSA



PEM® SNAP-TOP® standoffs.

## Bulletin MPF

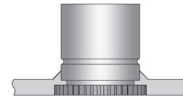

microPEM® standoffs.

For more information on how to use PEM® self-clinching standoffs, see Tech Sheet **"PEM®-Ref/Standoff Basics"** on our web site.

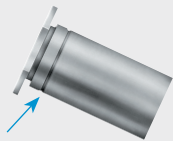

**PEM® "Single Groove"**  
(Registered trademark)  
Parts that install into  
stainless steel sheets

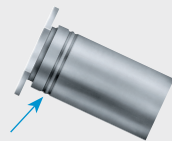

**PEM® "Two Groove"**  
(Registered trademark)

*Due to differences in manufacturing methods, location of grooves and surface appearance on barrel of actual parts may be different than shown in photo.*

## Thread Masking

PEM® PreTect™ thread masking plugs provide protection for PEM® internally threaded fasteners. They reduce labor and protect threads from paint and powder coating processes. Fasteners are shipped with plugs and film (where applicable) already in place. Plugs and film easily removed with a fine tip tool by end user. [Click here](#) for more information.

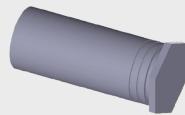

Fastener drawings and models are available at [www.pemnet.com](http://www.pemnet.com)

All PEM® products meet our stringent quality standards. If you require additional industry or other specific [quality certifications](#), special procedures and/or part numbers are required. Please contact your local sales office or representative for further information.

Regulatory [compliance information](#) is available in Technical Support section of our website. Specifications subject to change without notice. See our website for the most current version of this bulletin.

**PennEngineering®**



**North America:** Danboro, Pennsylvania USA ■ E-mail: [info@pemnet.com](mailto:info@pemnet.com) ■ Tel: +1-215-766-8853 ■ 800-237-4736 (USA)

**Europe:** Galway, Ireland ■ E-mail: [europa@pemnet.com](mailto:europa@pemnet.com) ■ Tel: +353-91-751714

**Asia/Pacific:** Singapore ■ E-mail: [singapore@pemnet.com](mailto:singapore@pemnet.com) ■ Tel: +65-6-745-0660

Shanghai, China ■ E-mail: [china@pemnet.com](mailto:china@pemnet.com) ■ Tel: +86-21-5868-3688

Visit our PEMNET™ Resource Center at [www.pemnet.com](http://www.pemnet.com) ■ Technical support e-mail: [techsupport@pemnet.com](mailto:techsupport@pemnet.com)