

REVISIONS			
REV.	DESCRIPTION	DATE	APPROVED
A	PR1210	15-APR-11	IDK
B	PR1210	29-AUG-11	IDK
C	EC4945	11-NOV-11	IDK

OUTPUT POWER TEST:
 UNIT AT RATED LINE VOLTAGE,
 1Vrms, 100Hz SINEWAVE INPUT AT PWR AMP IN JACK.
 IMPEDANCE SWITCH SET TO MATCH RESISTIVE LOAD
 CONNECTED TO MAIN SPKR JACK (8).
 100W MODE: ADJUST INPUT SIGNAL LEVEL TO VERIFY:
 100W (28.28Vrms) AT <5.0% THD INTO 8 OHMS.
 100W (20.00Vrms) AT <5.0% THD INTO 4 OHMS.
 100W (14.14Vrms) AT <5.0% THD INTO 2 OHMS.
 25W MODE: ADJUST INPUT SIGNAL LEVEL TO VERIFY:
 23W (13.56Vrms) AT <5.0% THD INTO 8 OHMS.
 23W (9.59Vrms) AT <5.0% THD INTO 4 OHMS.
 23W (6.78Vrms) AT <5.0% THD INTO 2 OHMS.

TP21-24 VARY DEPENDING ON BIAS SETTING.
 TUBE GRADE & POWER MODE. TYPICAL VALUES:

	COOL	NORMAL	WARM
100W	-60VDC	-55VDC	-50VDC
25W	-22VDC	-20VDC	-18VDC
OR SILENT R			

(FOR ALL TP21-24)

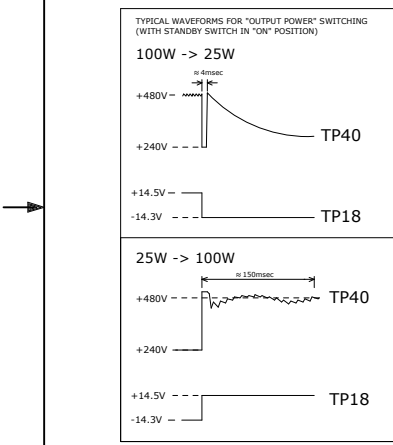
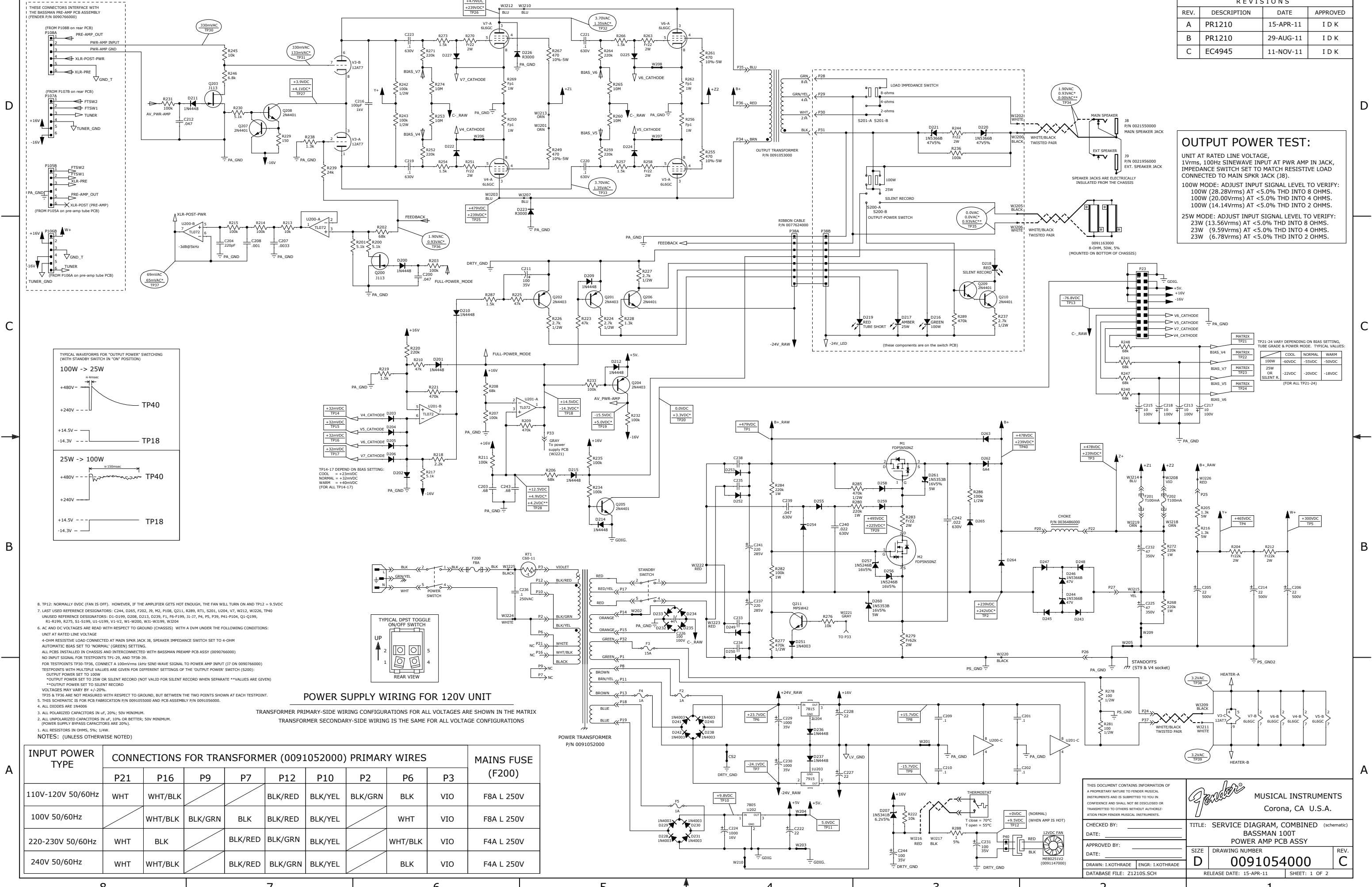

- TP12: NORMALLY 0VDC (FAN IS OFF). HOWEVER, IF THE AMPLIFIER GETS HOT ENOUGH, THE FAN WILL TURN ON AND TP12 = 9.5VDC
 - LAST USED REFERENCE DESIGNATORS: C244, D265, F202, J9, M2, P108, Q211, R289, RT1, S201, U204, V7, W212, W2225, TP40 UNUSED REFERENCE DESIGNATORS: D1-D199, D208, D213, D239, F1, F6-F199, J1-J7, P4, P5, P39, P41-P104, Q1-Q199, R1-R199, R275, S1-S199, U1-U199, V1-V2, W1-W200, W21-W209, W204
 - AC AND DC VOLTAGES ARE READ WITH RESPECT TO GROUND (CHASSIS) WITH A DVM UNDER THE FOLLOWING CONDITIONS:
 UNIT AT RATED LINE VOLTAGE
 4-OHM RESISTIVE LOAD CONNECTED AT MAIN SPKR JACK 8, SPEAKER IMPEDANCE SWITCH SET TO 4-OHM
 AUTOMATIC BIAS SET TO "NORMAL" (GREEN) SETTING.
 ALL PCBs INSTALLED IN CHASSIS AND INTERCONNECTED WITH BASSMAN PREAMP PCB ASSY (0090766000)
 NO INPUT SIGNAL FOR TESTPOINTS TP1-29, AND TP38-39.
 FOR TESTPOINTS TP30-TP36, CONNECT A 100mVrms 1kHz SINE-WAVE SIGNAL TO POWER AMP INPUT (I7 ON 0090766000)
 TESTPOINTS WITH MULTIPLE VALUES ARE GIVEN FOR DIFFERENT SETTINGS OF THE "OUTPUT POWER" SWITCH (S200):
 *OUTPUT POWER SET TO 100W
 *OUTPUT POWER SET TO 25W OR SILENT RECORD (NOT VALID FOR SILENT RECORD WHEN SEPARATE **VALUES ARE GIVEN)
 **OUTPUT POWER SET TO SILENT RECORD
 VOLTAGES MAY VARY BY +/-20%.
 TP35 & TP36 ARE NOT MEASURED WITH RESPECT TO GROUND, BUT BETWEEN THE TWO POINTS SHOWN AT EACH TESTPOINT.
 5. THIS SCHEMATIC IS FOR PCB FABRICATION P/N 0091055000 AND PCB ASSEMBLY P/N 0091056000.
 - ALL DIODES ARE 1N4006
 - ALL POLARIZED CAPACITORS IN uf, 20% ; 50V MINIMUM.
 - ALL UNPOLARIZED CAPACITORS IN uf, 10% OR BETTER; 50V MINIMUM.
 (POWER SUPPLY BYPASS CAPACITORS ARE 20%).
 1. ALL RESISTORS IN OHMS, 5% ; 1/4W.
- NOTES: (UNLESS OTHERWISE NOTED)

POWER SUPPLY WIRING FOR 120V UNIT

TRANSFORMER PRIMARY-SIDE WIRING CONFIGURATIONS FOR ALL VOLTAGES ARE SHOWN IN THE MATRIX
 TRANSFORMER SECONDARY-SIDE WIRING IS THE SAME FOR ALL VOLTAGE CONFIGURATIONS

INPUT POWER TYPE	CONNECTIONS FOR TRANSFORMER (0091052000) PRIMARY WIRES								MAINS FUSE (F200)	
	P21	P16	P9	P7	P12	P10	P2	P6		P3
110V-120V 50/60Hz	WHT	WHT/BLK			BLK/RED	BLK/YEL	BLK/GRN	BLK	VIO	F8A L 250V
100V 50/60Hz		WHT/BLK	BLK/GRN	BLK	BLK/RED	BLK/YEL		WHT	VIO	F8A L 250V
220-230V 50/60Hz	WHT	BLK		BLK/RED	BLK/GRN	BLK/YEL		WHT/BLK	VIO	F4A L 250V
240V 50/60Hz	WHT	WHT/BLK		BLK/RED	BLK/GRN	BLK/YEL		BLK	VIO	F4A L 250V

THIS DOCUMENT CONTAINS INFORMATION OF A PROPRIETARY NATURE TO FENDER MUSICAL INSTRUMENTS AND IS SUBMITTED TO YOU IN CONFIDENCE AND SHALL NOT BE DISCLOSED OR TRANSMITTED TO OTHERS WITHOUT AUTHORIZATION FROM FENDER MUSICAL INSTRUMENTS.

Fender MUSICAL INSTRUMENTS
 Corona, CA U.S.A.

CHECKED BY: _____ TITLE: SERVICE DIAGRAM, COMBINED (schematic)
 DATE: _____ BASSMAN 100T
 APPROVED BY: _____ POWER AMP PCB ASSY
 DATE: _____ SIZE: DRAWING NUMBER
 DRAWN: L.KOTHRAD EGR: L.KOTHRAD REV: C
 DATABASE FILE: Z12105.SCH RELEASE DATE: 15-APR-11 SHEET: 1 OF 2

8

7

6

5

4

3

2

1

REVISIONS			
REV.	DESCRIPTION	DATE	APPROVED
A	PR1210	08-JUL-11	I D K
B	PR1210	29-AUG-11	I D K
C	EC4945	11-NOV-11	I D K

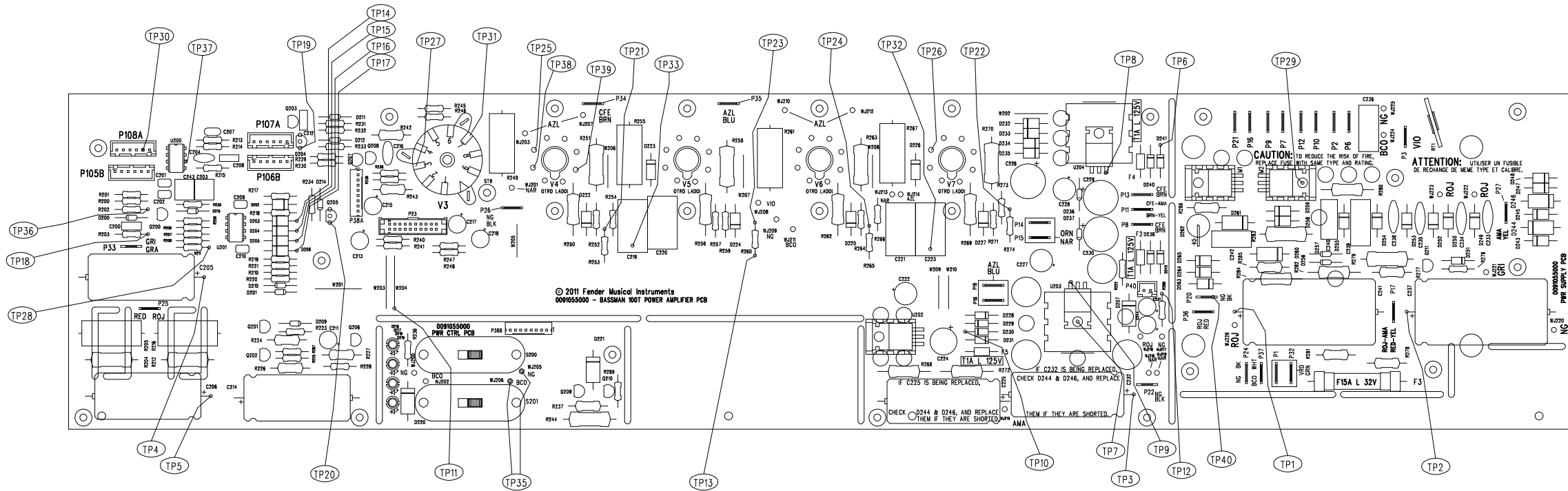

FILM/DWG: SERVICE DIAGRAM
 DATABASE: Z1210P.PCB DATE: 11-NOV-11

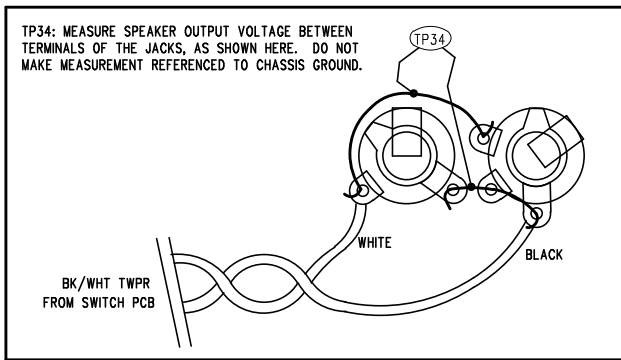

1. SEE SHEET 1 FOR NOTES AND TEST CONDITIONS.

NOTES: (UNLESS OTHERWISE NOTED)

THIS DOCUMENT CONTAINS INFORMATION OF A PROPRIETARY NATURE TO FENDER MUSICAL INSTRUMENTS AND IS SUBMITTED TO YOU IN CONFIDENCE AND SHALL NOT BE DISCLOSED OR TRANSMITTED TO OTHERS WITHOUT AUTHORIZATION FROM FENDER MUSICAL INSTRUMENTS.		MUSICAL INSTRUMENTS Corona, CA U.S.A.	
CHECKED BY:	DATE:	TITLE: SERVICE DIAGRAM, COMBINED (PCB Assy) BASSMAN 100T POWER AMP PCB ASSY	
APPROVED BY:	DATE:	SIZE: D	DRAWING NUMBER: 0091054000
DRAWN: KOTHRAD	ENGR: KOTHRAD	RELEASE DATE: 08-JUL-11	SHEET 2 OF 2
DATABASE FILE: Z1210P.PCB			REV. C

8

7

6

5

4

3

2

1

REVISIONS			
REV.	DESCRIPTION	DATE	APPROVED
A	PR1160	13-JUN-11	dBL

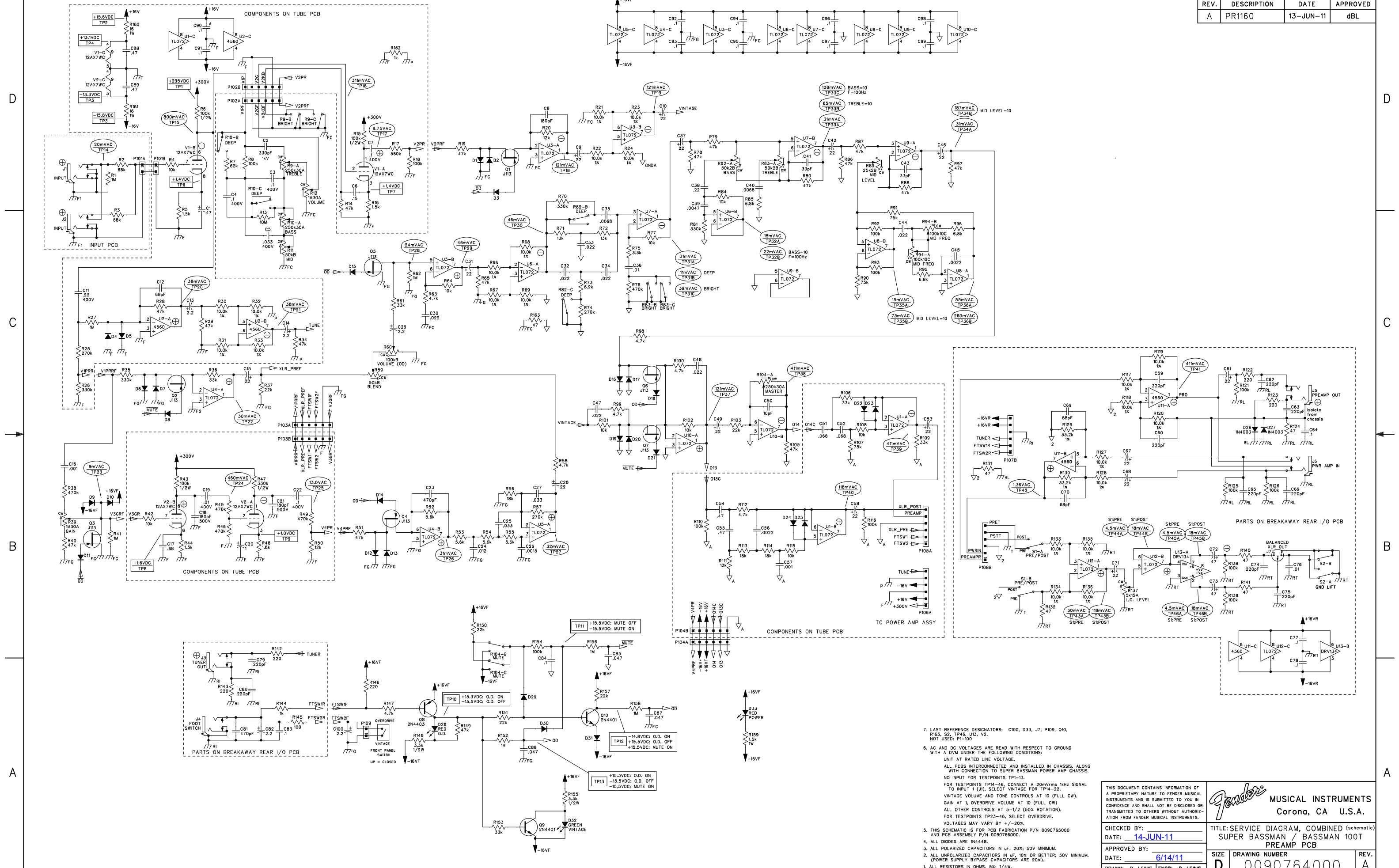

- LAST REFERENCE DESIGNATORS: C100, D33, J7, P109, O10, R163, S2, TP46, U13, V2. NOT USED: P1-100
- AC AND DC VOLTAGES ARE READ WITH RESPECT TO GROUND WITH A DMM UNDER THE FOLLOWING CONDITIONS:
UNIT AT RATED LINE VOLTAGE.
ALL PCBs INTERCONNECTED AND INSTALLED IN CHASSIS, ALONG WITH CONNECTION TO SUPER BASSMAN POWER AMP CHASSIS. NO INPUT FOR TESTPOINTS TP1-13.
FOR TESTPOINTS TP14-46, CONNECT A 20mVrms 1kHz SIGNAL TO INPUT 1 (I). SELECT VINTAGE FOR TP14-22.
VINTAGE VOLUME AND TONE CONTROLS AT 10 (FULL CW). GAIN AT 1. OVERDRIVE VOLUME AT 10 (FULL CW). ALL OTHER CONTROLS AT 5-1/2 (50% ROTATION).
FOR TESTPOINTS TP23-46, SELECT OVERDRIVE. VOLTAGES MAY VARY BY +/-20%.
- THIS SCHEMATIC IS FOR PCB FABRICATION P/N 0090765000 AND PCB ASSEMBLY P/N 0090766000.
- ALL DIODES ARE IN4448s.
- ALL POLARIZED CAPACITORS IN Uf, 20%; 50V MINIMUM.
- ALL UNPOLARIZED CAPACITORS IN Uf, 10% OR BETTER; 50V MINIMUM. (POWER SUPPLY BYPASS CAPACITORS ARE 20%).
- ALL RESISTORS IN OHMS, S; 1/4W.

NOTES: (UNLESS OTHERWISE NOTED)

THIS DOCUMENT CONTAINS INFORMATION OF A PROPRIETARY NATURE TO FENDER MUSICAL INSTRUMENTS AND IS SUBMITTED TO YOU IN CONFIDENCE AND SHALL NOT BE DISCLOSED OR TRANSMITTED TO OTHERS WITHOUT AUTHORIZATION FROM FENDER MUSICAL INSTRUMENTS.

Fender MUSICAL INSTRUMENTS
Corona, CA U.S.A.

CHECKED BY: _____ DATE: 14-JUN-11
APPROVED BY: _____ DATE: 6/14/11
DRAWN: D. LEWIS ENGR: D. LEWIS DATABASE FILE: Z1160S1.SCH

TITLE: SERVICE DIAGRAM, COMBINED (schematic) SUPER BASSMAN / BASSMAN 100T PREAMP PCB
SIZE: _____ DRAWING NUMBER: 0090764000 REV. A
RELEASE DATE: 13-JUN-11 SHEET: 1 OF 2

REVISIONS			
REV.	DESCRIPTION	DATE	APPROVED
A	PR1160	13-JUN-11	dBL

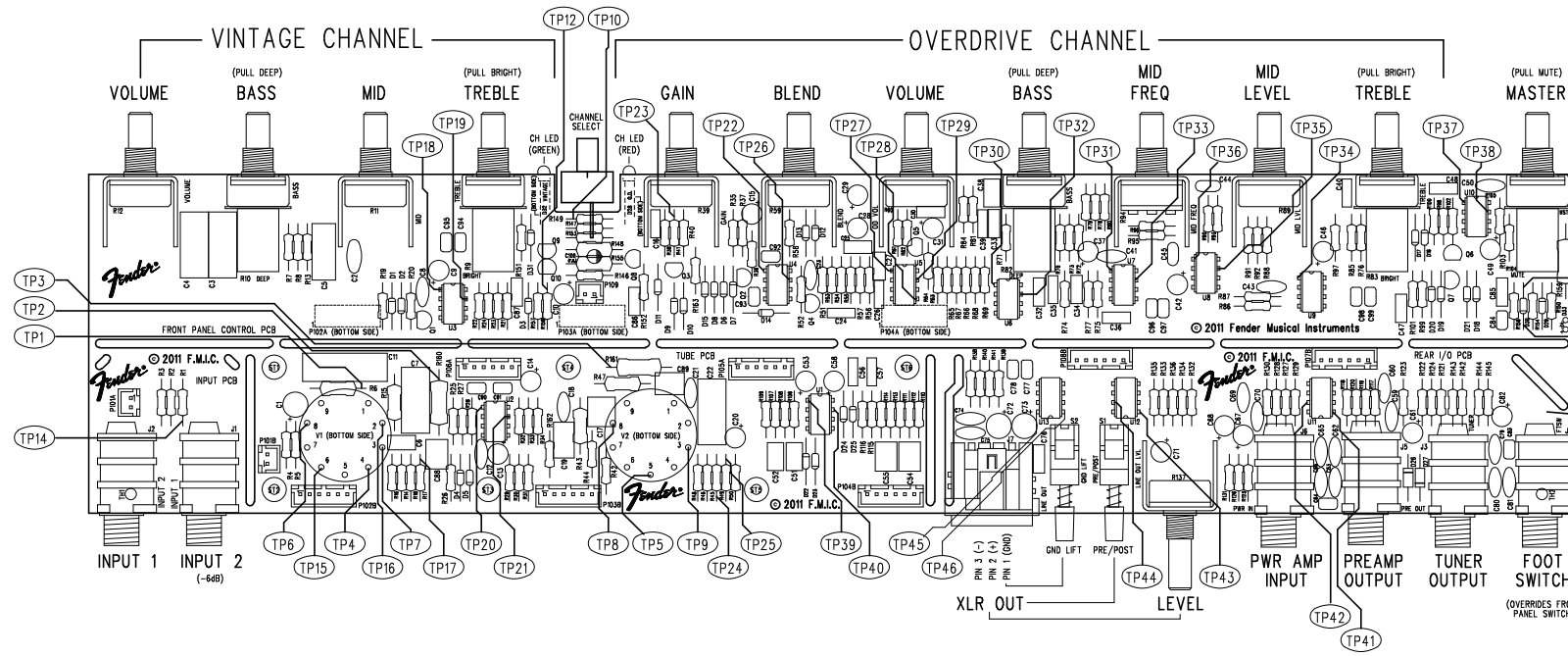

BREAKAWAY I/O PCB LOCATED IN POWER AMP CHASSIS (SUPER BASSMAN ONLY)

FILM/DWG: SERVICE DIAGRAM
 DATABASE: Z1160P1.PCB DATE: 13-JUN-11

2. THE FOLLOWING PCB INTERCONNECTS ARE REQUIRED:
 COAX CABLE CONNECTED FROM P101A - P101B.
 6CKT RIBBON CABLES CONNECTED FROM P102A - P102B, P103A - P103B, P104A - P104B.
 2X6CKT RIBBON CABLE CONNECTED AT P105A AND P106A TO POWER CHASSIS (SUPER BASSMAN ONLY).
 6CKT RIBBON CABLES CONNECTED FROM P105A - P105B, P106A - P106B (BASSMAN 100T ONLY).
 6CKT RIBBON CABLES CONNECTED FROM P107A - P107B, P108A - P108B (NOTE: INSIDE POWER CHASSIS ON SUPER BASSMAN).

1. SEE SHEET 1 FOR TEST CONDITIONS AND TEST POINT VALUES.

NOTES: (UNLESS OTHERWISE NOTED)

THIS DOCUMENT CONTAINS INFORMATION OF A PROPRIETARY NATURE TO FENDER MUSICAL INSTRUMENTS AND IS LOANED TO YOU IN CONFIDENCE AND SHALL NOT BE DISCLOSED OR TRANSMITTED TO OTHERS WITHOUT AUTHORIZATION FROM FENDER MUSICAL INSTRUMENTS.		MUSICAL INSTRUMENTS Corona, CA U.S.A.	
CHECKED BY:	DATE: 14-JUN-11	TITLE: SERVICE DIAGRAM, COMBINED (PCB Assy) SUPER BASSMAN / BASSMAN 100T PREAMP	
APPROVED BY:	DATE: 6/14/11	SIZE: D	DRAWING NUMBER: 0090764000
DRAWN: D. LEWIS	ENGR: D. LEWIS	RELEASE DATE: 13-JUN-11	SHEET 2 OF 2
DATABASE FILE: Z1160PLPCB			