

SERVICE MANUAL

VOX VT15



TABLE OF CONTENTS

ASSEMBLY SKETCH : 2-3

BLOCK DIAGRAM: 4

SCHEMATIC DIAGRAM: 5-6

PARTS LIST: 7-8



Issued: Nov.7, 2008

Ver.1.1

©2008 VOX AMPLIFICATION LTD.

DWG.NO. ASSY0218-01

NO	DESCRIPTION	SPECIFICATION	Q'TY	TORQUE SPEC
1	MAIN PCB ASS'Y	VT15	1	
2	POWER PCB ASS'Y	VT15	1	
3	MAIN CHASSIS	EGI 1.0t	1	
4	FRONT PANEL	PVC 0.5t HAIR LINE	1	
5	REAR PANEL	PS 0.5t	1	
6	PCB SUPPORT	METAL	7	
7	KNOB	ABS (CHIKEN HEAD)	8	
8	TACT KNOB "A"	NBR	9	
9	TACT KNOB "B"	NBR	1	
10	KNOB SMALL	ABS (200VTX)	3	
11	LEAD BUSHING	φ5	1	
12	SCREW	MBSSW 3x6 NI	17	6kgf.cm
13	SCREW	TBQSSW 3X6 BK	3	11-12kgf.cm
14	SCREW	MWS 4X10 NI	3	14kgf.cm
15	SCREW	MBS 3X10NI	1	6kgf.cm
16	FLANGE NUT	M4	3	
17	VOLUME NUT	M7	11	8kgf.cm
18	INLET	SC-8F-21	1	
19	JACK NUT	ABS BLACK	1	6kgf.cm
20	POWER SWITCH	RL3-421	1	
21	HEAT SINK	AL 2t	1	
22	INPUT JACK PCB	VT15	1	
23	POWER TRANS		1	
24	INPUT JACK WASHER		1	
25	INPUT JACK NUT		1	
26	RUBBER BUSHING	φ12	1	
27	VACCUME TUBE	12AX7	1	
28	TUBE RETAINER	SUS φ1	1	
29	INSULATOR BUSHING	T0-220(φ3)	1	
30	SILICON PAD	T0220(S)	1	
31	SPRING WASHER	φ3 NI	1	
32	NUT	M3 NI	1	
33	INTERNAL TOOTH WASHER	φ4 NI	1	
34	SCREW	TBQS 3X6 NI	1	
35	VOLUME WASHER	φ7	3	

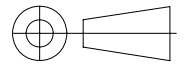

THIRD ANGLE PROJECTION

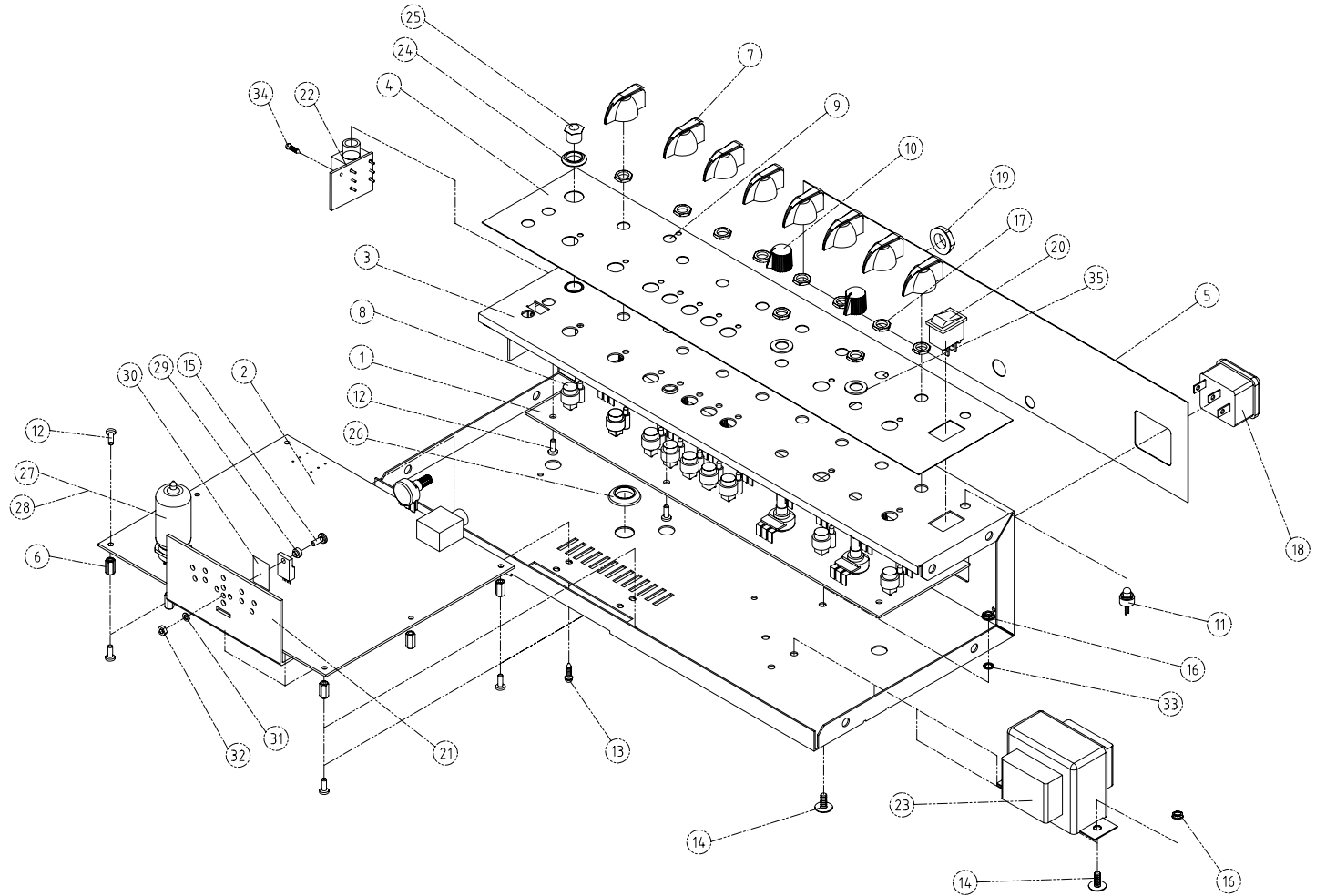

REV. NO.	REV. DATE	DESCRIPTIONS OF REVISION
C		
B		
A		

MATERIAL	DIMENSION	SCALE	TITLE	SHEET
THICKNESS	mm	N/S	CHASSIS ASSY	10F1
FINISH	MODEL	VT15	DWG. NO.	VER.
			ASSY0218-01	A
TOLERANCE UNLESS NOTE	DRAWN	DATE	 KIMANSON Kimanson Instruments CO., Ltd.	
DIMENSIONAL ±	S.K. HAN	2008.01.28		
HOLE CENTERS ±	CHECKED	DATE		
DIAMETERS ±	APPROVED	DATE		
ANGULAR ±				

DWG.NO. ASSY0218-02

NO	DESCRIPTION	SPECIFICATION	Q'TY	TORQUE SPEC
1	CHASSIS ASSY	VT15	1	
2	SPEAKER	8"	1	
3	FRANGE NUT	M4	4	
4	WOODEN CABINET	PB151	1	
5	HANDLE BAR	PVC	1	
6	HANDLE EDGE	ZN DIECASTING Cr	2	
7	BRAND MARK	VOX (LARGE) SILVER	1	
8	SPEAKER GRILL	SPC1 1.2f NI	1	
9	RUBBER FOOT	SBR SMALL	4	
10	CORNER	NYLON	6	
11	GRILL SUPPORT	NYLON	6	
12	VENT GRILL	ABS	1	
13	SCREW	MTSPW 5X27 BK	8	16 kgfcm
14	SCREW	MTSPW 5X23 BK	6	15-16 kgfcm
15	SCREW	MOS 4 X 20 NI	4	14-15 kgfcm
16	SCREW	TTLSK 4X30 BK	8	19-20 kgfcm
17	SCREW	TWLS 3.5 X 15 BK	4	11-12 kgfcm
18	SCREW	TTLS 3.5 X 13 BK	12	11-12 kgfcm
19	SCREW	TTLS 3.5 X 15 NI	6	11-12 kgfcm
20	RUBBER SPONGE	150x5x2f BK	2	
21	EMBLEM	VALVETRONICS SILVER	1	

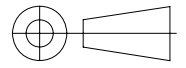

THIRD ANGLE PROJECTION

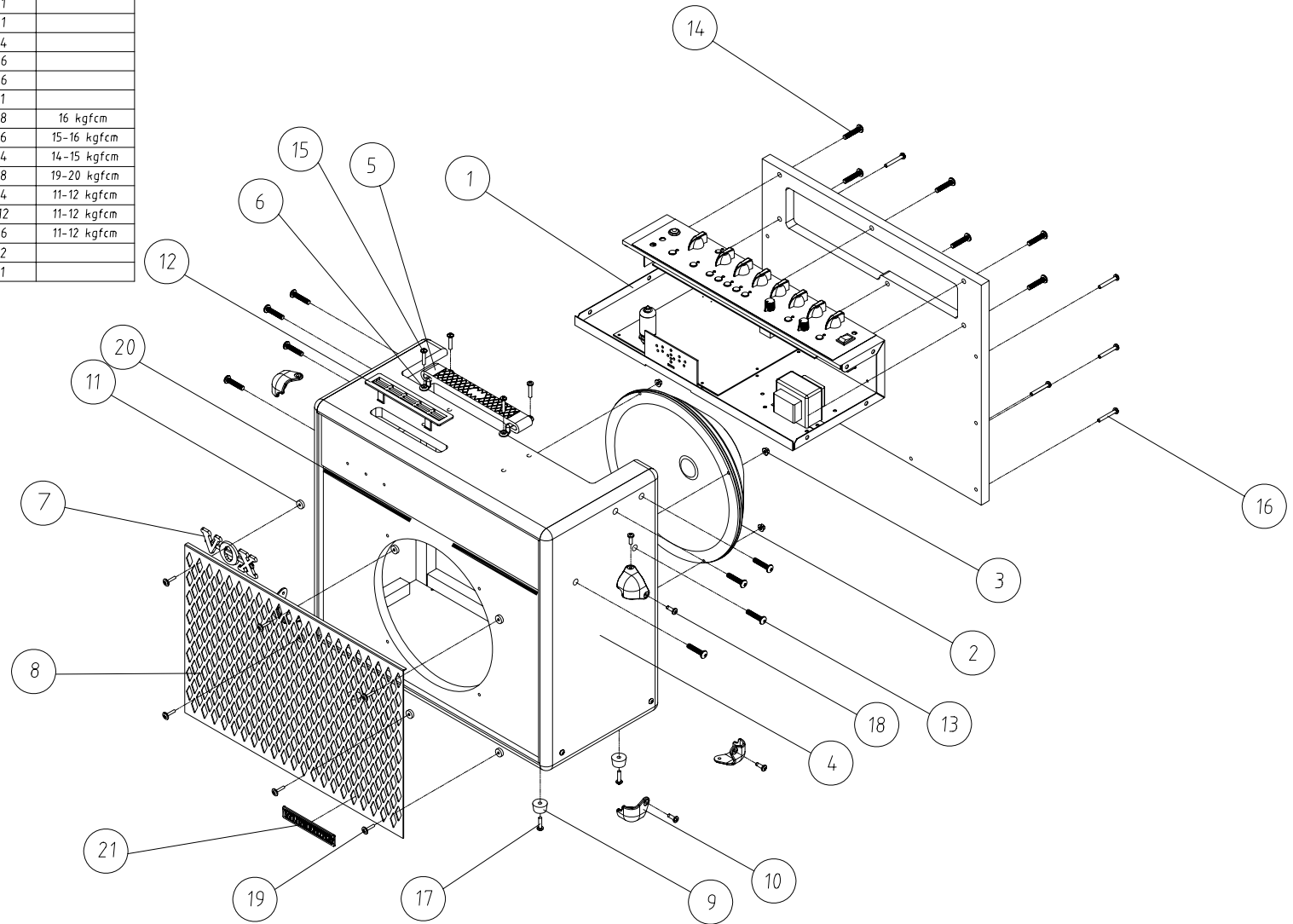

REV. NO.	REV. DATE	DESCRIPTIONS OF REVISION

MATERIAL	DIMENSION	SCALE	TITLE	SHEET
THICKNESS	mm	N/S	SET ASS'Y	10F1
FINISH	MODEL	VT15	DWG. NO.	VER.
TOLERANCE UNLESS NOTE	DRAWN	DATE	ASSY0218-02	A
DIMENSIONAL ±	S,K HAN	2008,01,28		
HOLE CENTERS ±	CHECKED	DATE		
DIAMETERS ±	APPROVED	DATE		
ANGULAR ±				
			 KIMANSON Kimanson Instruments CO., Ltd.	

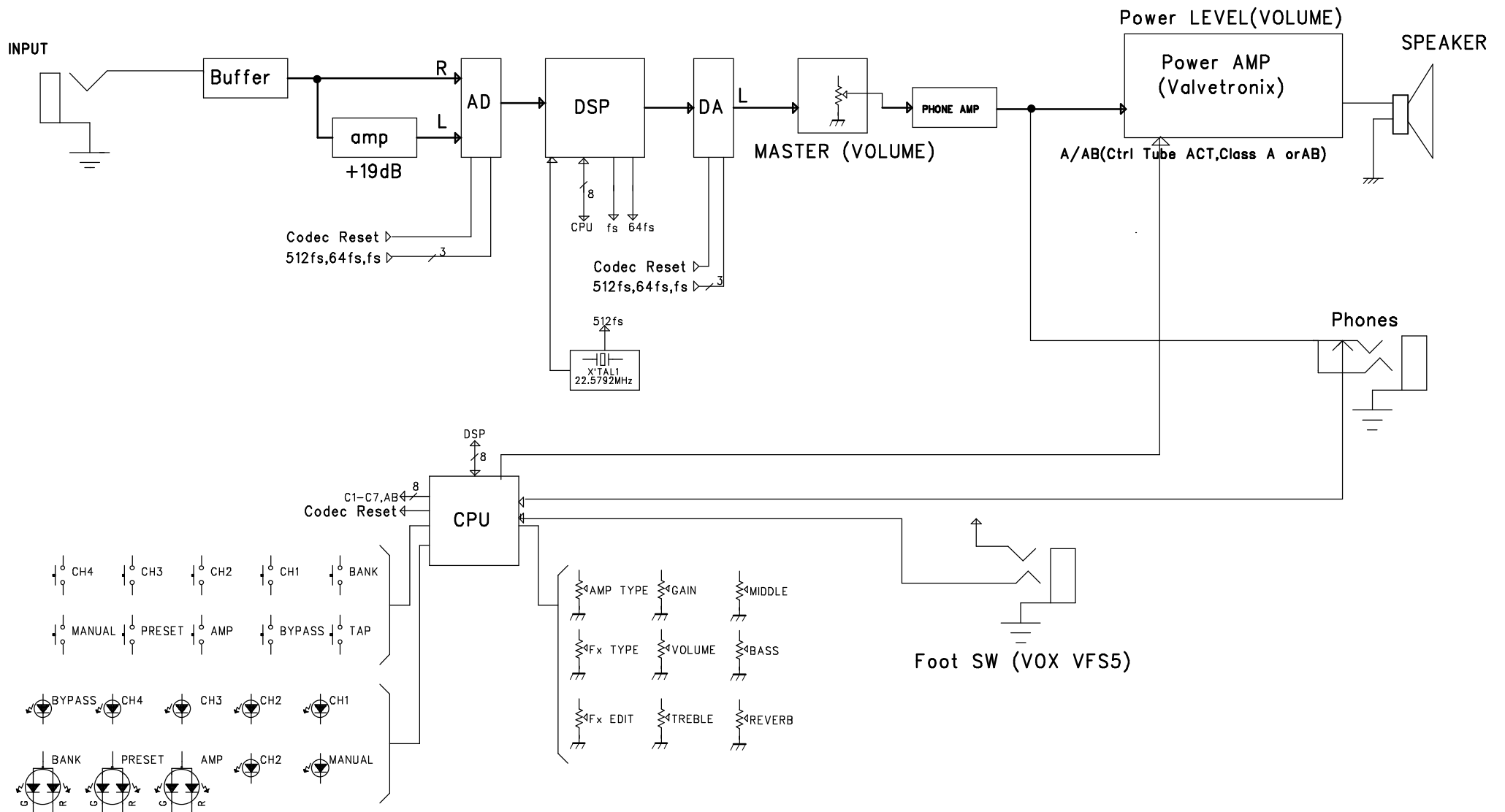

△			
△			
△			
△			
△			
MARK	REVISION REASON	DATE	REVISED BY

DESIGNED BY	CHECKED BY	APPROVED BY	MODEL VT 15/30
M.Tohyama			TITLE
			Block Diagram
KORG		DRAWING NO.	DATE
		Ver1.0	2008.03.07

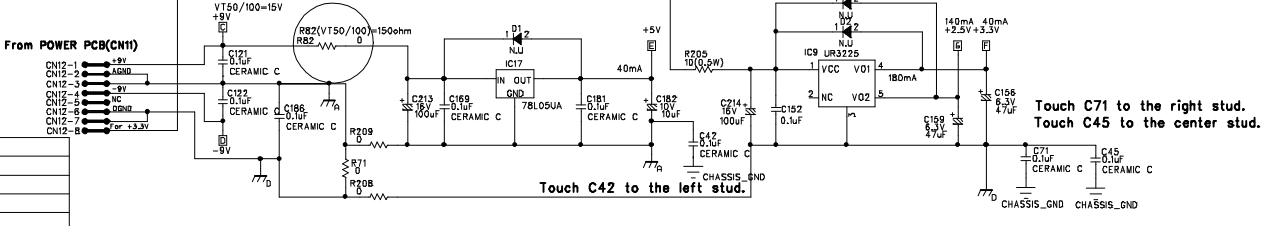
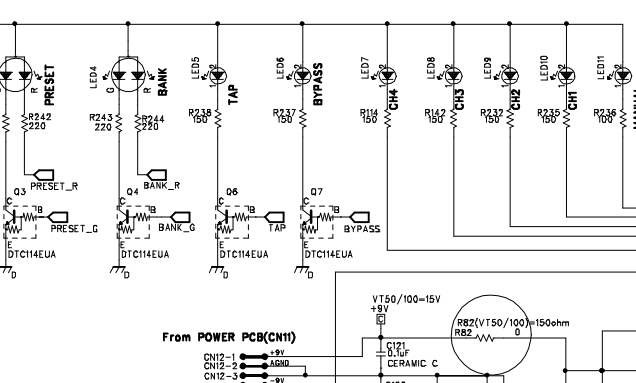
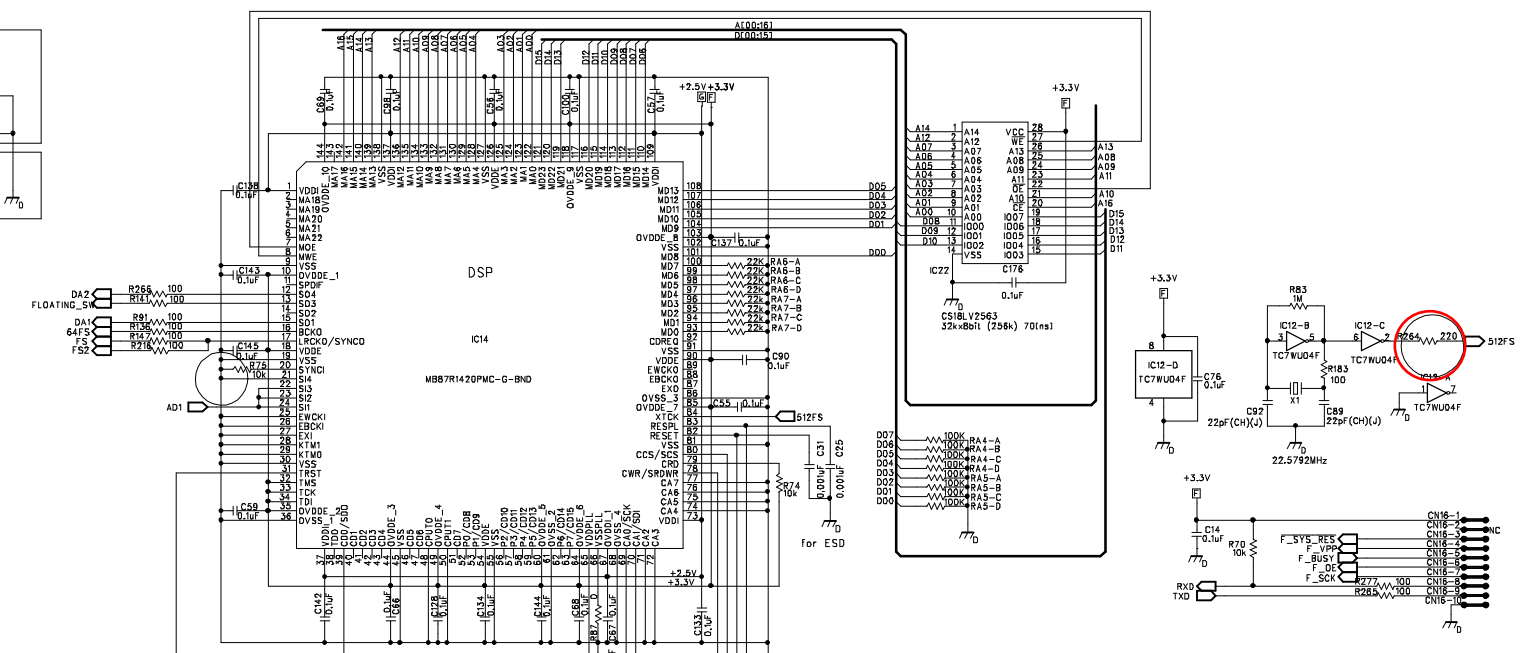
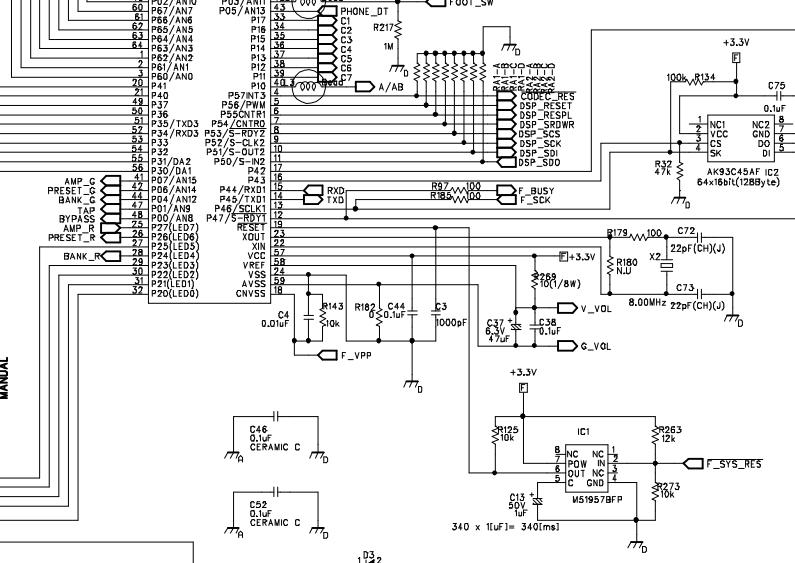
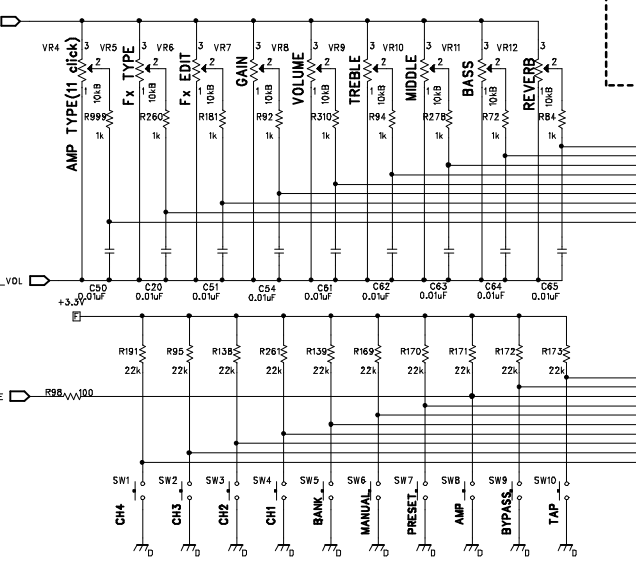
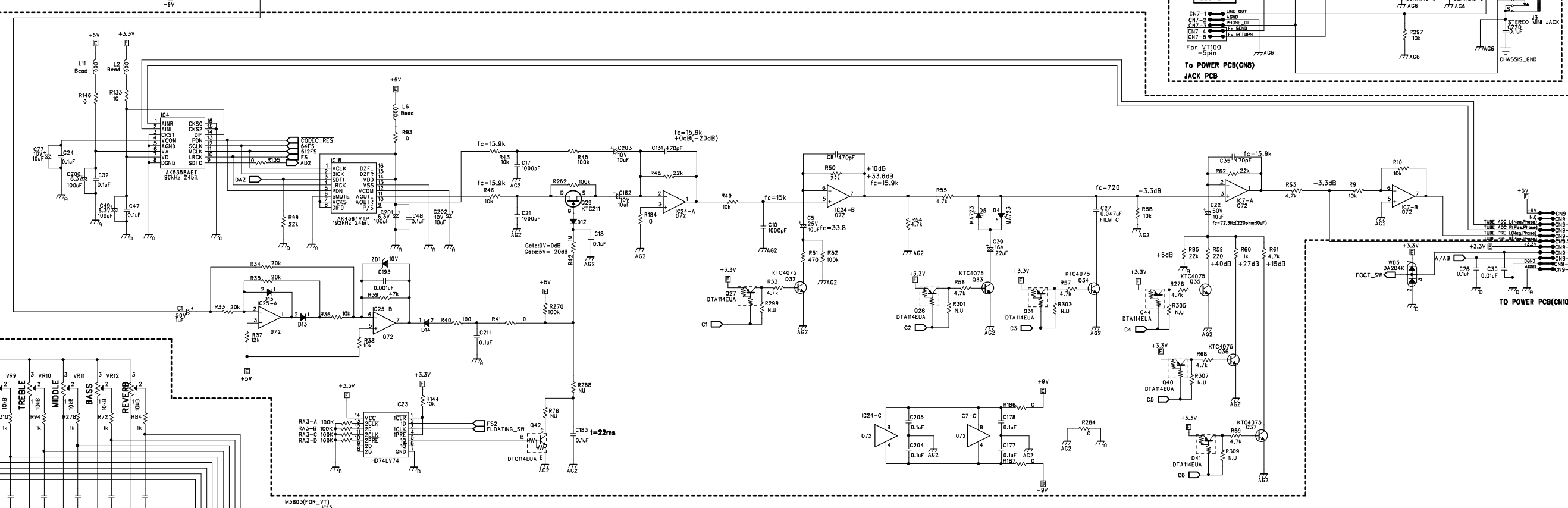
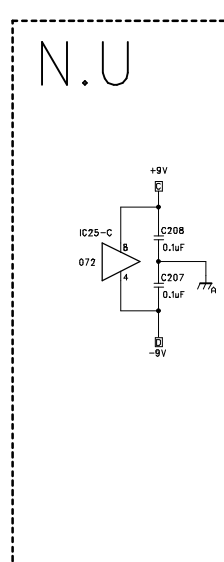
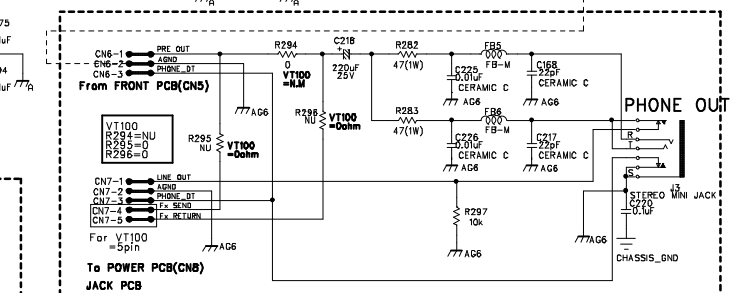
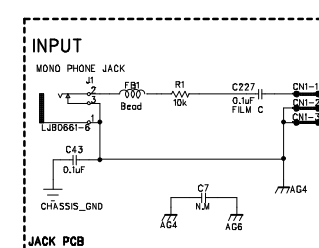
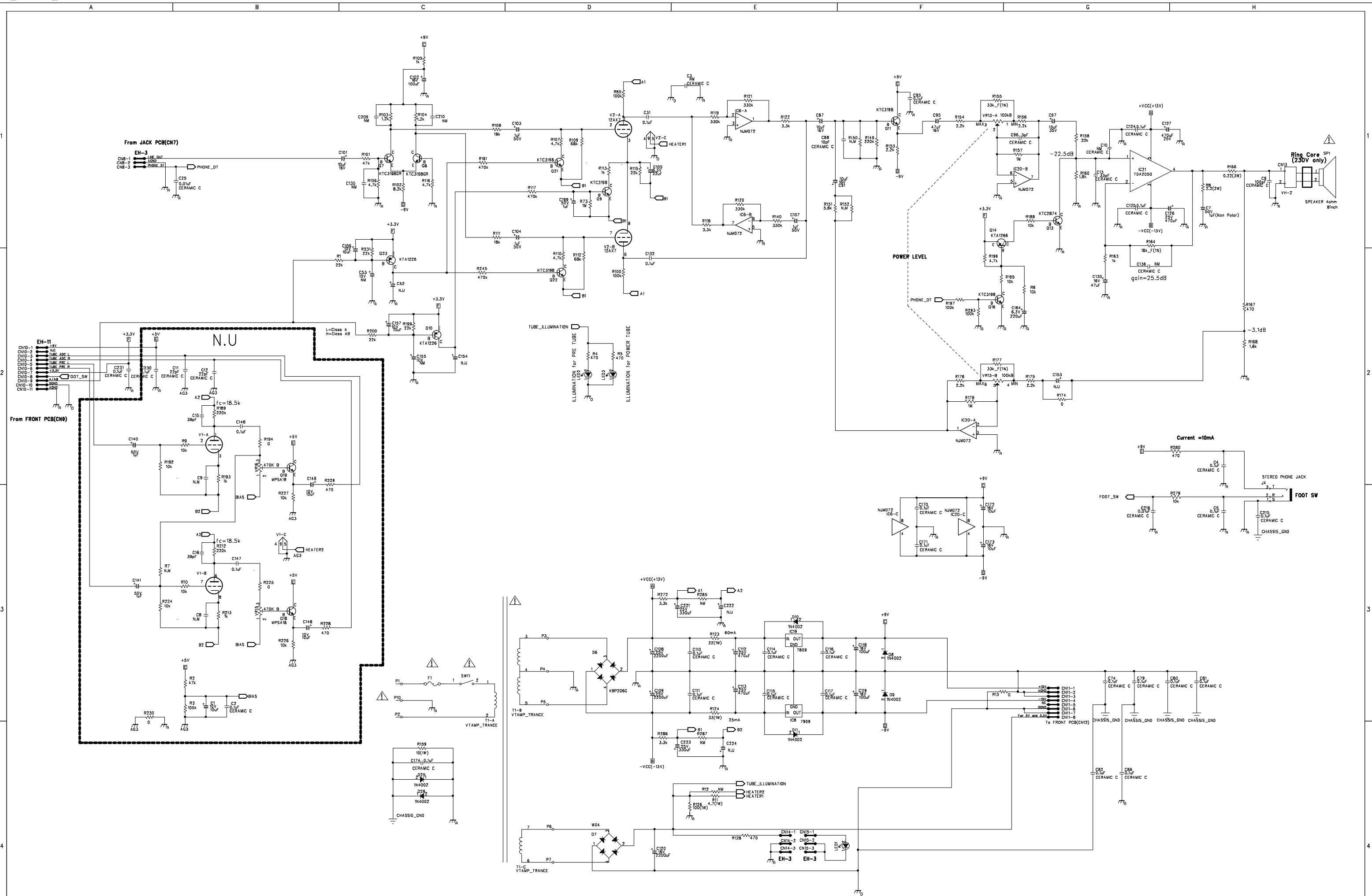

Table with 4 columns: MARK, REVISION REASON, DATE, REVISED BY.



MARK	REVISION REASON	DATE	REVISED BY

DRAWN BY	DESIGNED BY	CHECKED BY	MODEL	VT 15
Y.Shitani	M.Tohyama		TITLE	POWER CIRCUIT V1.0.1
KORG			DRAWING NO.	DATE
				2008.07.24

VOX VT15 Parts List

⚠ = SAFETY CRITICAL COMPONENT.

Component must be replaced only by the component specified in this list.

Parts Number	Category	Parts Name (KORG)	Location	Reference	QTY
530000001086	CHIP INDUCTOR	HH-1M2012-121	JACK PCB	FB1,FB5,FB6	3
530000001147	HARNESS	3P WIRE BOARD IN 100MM	JACK PCB		1
530000001100	PHONE JACK	BPJ-BNB-6.5(NUT/BLACK)	JACK PCB		1
530000001104	PHONE JACK	PJ3039 (3.5PIE)	JACK PCB		1
530000001094	OPAMP	NJM072 (SMT)	MAIN PCB	IC5	1
530000000813	OPAMP	NJM4556M	MAIN PCB	IC3	1
500324018020	DA CONVERTER	AK4384ET-E2	MAIN PCB	IC16	1
500320011255	CPU	M38039G8H-603HP U0	MAIN PCB	IC15	1
500320012334	DSP	MB87R1420PMC-G-BND	MAIN PCB	IC14	1
530000000183	SRAM	CS18LV02563AC-70	MAIN PCB	IC22	1
530000000189	RESET IC	KIA7125FV	MAIN PCB	IC1	1
500324018021	AD CONVERTER	AK5358AET-E2	MAIN PCB	IC11	1
530000000180	EEPROM	AK93C45AF	MAIN PCB	IC2	1
530000001095	3-INVERTOR	TC7WU04F	MAIN PCB	IC12	2
530000001096	DIGITAL TR	DTC114EUA	MAIN PCB	DT1,DT2,DT3,DT4,DT17	5
530000001097	REGULATOR	78L05UA	MAIN PCB	IC17	1
530000001098	REGULATOR	UTC UR3325	MAIN PCB	IC9	1
530000000271	CHIP TRANSISTOR	KTA2014	MAIN PCB	Q5	1
530000000275	CHIP TRANSISTOR	KTC2875	MAIN PCB	Q1	2
530000000159	DOUBLE DIODE	DA204K	MAIN PCB	WD1,WD2,WD3	3
530000000144	CHIP INDUCTOR	HH-1M2012-600	MAIN PCB	L21,L17,L20	3
530000001087	CRYSTAL	8.00MHZ	MAIN PCB	X2	1
530000001088	CRYSTAL	22.5792MHZ	MAIN PCB	X1	1
530000000288	VOLUME	VR RV160-40-15S-B10K-C0	MAIN PCB	VR3, VR6~VR12	8
530000000289	VOLUME	VR RV160-40-15S-B10K-C11 (11CLICK)	MAIN PCB	VR4, VR5	2
530000000265	TACT SWITCH	ATS-1230B (K=9.5MM)	MAIN PCB	SW1-SW10	10
530000000208	LED	LED RED 3M/M DLL-B5131Q	MAIN PCB	LED5-LED11	7
530000001102	LED	3RG9HW-2-A	MAIN PCB	LED2,LED3,LED4	3
530000000762	CONNECTOR	WAFER (GIL-S-3P-S2T2)	MAIN PCB	CN2,CN5	2
530000000760		LED SUPPORT	MAIN PCB		7
⚠ 530000001148	HARNESS	8P LEAD WIRE BOARD IN 230MM	MAIN PCB		1
⚠ 530000001149	HARNESS	5P LEAD WIRE BOARD IN 320MM	MAIN PCB		1
530000001124		TACT KNOB "A" NBR 9PIE	MAIN PCB		9
530000001125		TACT KNOB "B" NBR 7PIE	MAIN PCB		1
530000001114		LED SUPPORT 9MM	MAIN PCB		3
530000000196	POWER IC	TDA2050	POWER PCB	IC21	1
530000001091	OP-AMP	NJM072D (DIP)	POWER PCB	IC6,IC20	2
530000001092	REGULATOR	KA7909	POWER PCB	IC8	1
530000001093	REGULATOR	KA7809	POWER PCB	IC19	1
530000001103	LED	3O4HD-7	POWER PCB	LED2	1
530000000207	LED	DLL-50231(R114)	POWER PCB	LED1	1
530000000290	POTENTIOMETER	RV162-20-15SP-B100K	POWER PCB	VR13	1
530000000140	BRIDGE DIODE	KBP206G	POWER PCB	D6	1
530000000142	BRIDGE DIODE	W04M	POWER PCB	D7	1
530000000150	DIODE	1N4002	POWER PCB	D8,D9,D10,D11,D25,D26	6
530000000277	TRANSISTOR	KTC3198-GR	POWER PCB	Q7,Q8,Q9,Q11,Q16,Q21,Q22	7
530000000268	TRANSISTOR	KTA1266GR	POWER PCB	Q10,Q14,Q23	3
530000000273	TRANSISTOR	KTC2874	POWER PCB	Q13	1
530000001116	CONNECTOR	WAFER LWL0640 3P	POWER PCB	CN7	1
530000001115	CONNECTOR	WAFER LWL0640 5P	POWER PCB	CN9	1
530000000764	CONNECTOR	WAFER LWL0640 8P	POWER PCB	CN12	1
530000001099		SILICON PAD TO220(S)	POWER PCB		1
530000000840		INSULATOR BUSHING TO-220(3PIE)	POWER PCB		1
530000000797	STEREO JACK	EPJ-BBB-P 8mm	POWER PCB	J4	1
530000001101	TUBE SOCKET	GZC9-A	POWER PCB	V2	1
⚠ 530000001122		HEAT SINK VT15	POWER PCB		1
530000001117		TUBE RETAINER	POWER PCB		1
530000000883		PCB SUPPORT BRASS 10MM	POWER PCB		7
530000001143	PCB ASS'Y	JACK PCB ASSY VT 15/30	CHASSIS		1
530000001144	PCB ASS'Y	MAIN PCB ASSYVT 15/30	CHASSIS		1
530000001145	PCB ASS'Y	POWER PCB ASSY VT15	CHASSIS		1
530000000745		RING CORE (OP18C)	CHASSIS	230V ONLY	1

Parts Number	Category	Parts Name (KORG)	Location	Reference	QTY
△ 530000001118		MAIN CHASSIS VT 15	CHASSIS		1
530000001128		FRONT PANEL VT 15	CHASSIS		1
△ 530000001130		REAR PANEL 100V (VT15)	CHASSIS		(1)
△ 530000001131		REAR PANEL 120V (VT15)	CHASSIS		(1)
△ 530000001132		REAR PANEL 230V (VT15)	CHASSIS		(1)
△ 530000001133		REAR PANEL 240V (VT15)	CHASSIS		(1)
530000001126		VOLUME KNOB CHIKEN HEAD CLEAM	CHASSIS		8
530000001127		ROUND KNOB	CHASSIS		3
530000000206		LED BUSHING	CHASSIS		1
530000000839		RUBBER BUSHING PAI12	CHASSIS		1
△ 530000001105	TRANSFORMER	TRANS 100V = 057-VT15J	CHASSIS		(1)
△ 530000001106	TRANSFORMER	TRANS 120V = 057-VT15U	CHASSIS		(1)
△ 530000001107	TRANSFORMER	TRANS 220-230V = 057-VT15E	CHASSIS		(1)
△ 530000001108	TRANSFORMER	TRANS 240V = 057-VT15EF	CHASSIS		(1)
△ 530000001090	FUSE	T630MA L 250V	CHASSIS	FUSE 100V/120V	(1)
△ 530000001089	FUSE	T400MA L 250V	CHASSIS	FUSE 230V/240V	(1)
△ 530000000832	POWER SWITCH	APS-1101HV0(RL3-111)	CHASSIS		1
△ 530000000199	INLET/FUSE HOLDER	SC-8F-21	CHASSIS		1
530000000282	TUBE	12AX7EH	CHASSIS		1
530000001138		RUBBER SPONGE 30*30*1T	CHASSIS		1
530000001150		CHASSIS ASS'Y VT 15 100V		CHASSIS ASS'Y	(1)
530000001151		CHASSIS ASS'Y VT15 120V			(1)
530000001152		CHASSIS ASS'Y VT15 230V			(1)
530000001153		CHASSIS ASS'Y VT15 240V			(1)
△ 530000001113	SPEAKER	TLS200G0426-1			1
△ 530000001085		CABINET ASS'Y VT 15			1
△ 530000000313		HANDLE ASS'Y			1
530000000138	BRAND MARK	VOX (LARGE) SILVER			1
530000000160	EMBLEM	VALVETRONICS SILVER			1
530000001120		GRILL VT 15			1
△ 530000000767		VENT GRILL			1
530000000252		RUBBER FOOT SBR SMALL			4
530000000146		CORNER NYLON 6/6 COR0012-A			6
530000000875		RUBBER SPONGE 150X5X2T		SPEAKER GRILL	2
530000001139		RUBBER SPONGE 30*18*2T		TUBE	1
△ 500600006508	AC CORD	LY100JPVCTFLY35LY37		100V	(1)
△ 500540028903	ADAPTER PLUG	YL-212		100V	(1)
△ 530000000123	AC CORD	120V = KKP30-16A		120V	(1)
△ 530000000124	AC CORD	230V = KKP4819R-16A		230V	(1)
△ 530000000125	AC CORD	230V = KKP650-16A		230V	(1)
△ 530000000126	AC CORD	240V = KKP550-16A		240V	(1)