

TEAC

SERVICE MANUAL

DR-H300DAB

DVD/DAB Receiver



NOTES

- PC board shown are viewed from parts side.
- The parts with no reference number or no parts number in the exploded views are not supplied.
- As regards the resistors and capacitors, refer to the circuit diagrams contained in this manual.
- ⚠ Parts marked with this sign are safety critical components. they must be replaced with identical components - refer to the appropriate parts list and ensure exact replacement.
- Parts of [] mark can be used only with the version designated.
[E]: Europe [UK]: U.K

CONTENTS

1 SPECIFICATIONS	2
2 EXPLODED VIEW AND PARTS LIST	3
3 PC BOARDS AND PARTS LISTS	5
4 WIRING DIAGRAM	14
5 INCLUDED ACCESSORIES	15

DR-H300DAB

1 SPECIFICATIONS

DVD Player

Pick up :	Semiconductor laser, Wave length 650/790nm
Signal System:	NTSC/PAL
Video signal horizontal:	More than 480 lines (DVD)
Video signal-to noise ratio:	More than 50 dB (DVD)
Audio frequency response:	20 Hz to 20kHz (+/-3dB)
Audio signal-to noise ratio:	62 dB
Dynamic range:	80 dB

S-Video output	
Y (luminance) - Output level:	1 Vp-p (75 ohm)
C (color) - Output level:	286 mVp-p (75 ohm)
Jacks:	S-VIDEO jack

Video output	
Output level:	1.0 Vp-p (75 ohm)
Jacks:	RCA jack

Component video output (Y, C _B /P _B , C _R /P _R)	
Y-Output level:	1.0 Vp-p (75 ohm)
C _B /P _B , C _R /P _R -Output level:	0.7Vp-p (75 ohm)
Jacks:	RCA jacks

AV connector	
Jack:	SCART

HDMI output	
Jack:	HDMI 19 pin (version 1.1)

Amplifier

Output Power	
(Stereo, EIAJ, 20 Hz to 20 kHz, 4ohm)	50W + 50W
(Stereo, 1% THD, 20 Hz to 20 kHz, 4ohm)	36W + 36W
Total harmonic distortion	0.7% (at 5 W, 1kHz, 4ohm)
Audio Input sensitivity/impedance: LINE:	600 mV/47 kohm
Output level/impedance (LINE OUT)	100 mV/10kohm
Frequency Response	20 Hz to 20 kHz, +/-3 dB
Signal-to-noise Ratio	90 dB (IHF-A)

FM Tuner Section (Without notes 100.1 MHz, 65 dBf)

Tuning Range	87.5 MHz to 108.0 MHz (50 kHz steps)
Total Harmonic Distortion(1 kHz)	Mono: 1%, Stereo: 1.5%
Frequency Response	40 Hz to 10 kHz
Stereo Separation (1kHz)	35 dB
Signal-toNoise Ratio	Mono: 55 dB Stereo: 45 dB

DAB Tuner Section

Tuning Range:	Band III: 5A to 13F (174.928MHz to 239.200 MHz)
---------------	--

GENERAL

Power Requirements:	AC230V, 50 Hz
Power Consumption:	50 W (standby: 0.98W)
Dimension (W x H x D):	215 x110 x350 mm
Weight: (net)	4.5 kg

Standard Accessories:

Remote Control Unit x 1
DAB Antenna x 1
Batteries 1.5V x 1
RCA video cable x 1
Owner's Manual x 1
Warranty Card x 1

- Design and specifications are subject to change without notice.
- Illustrations may differ slightly from production models.
- Weight and dimensions are approximate.

2 EXPLODED VIEWS AND PARTS LIST

EXPLODED VIEW - 1

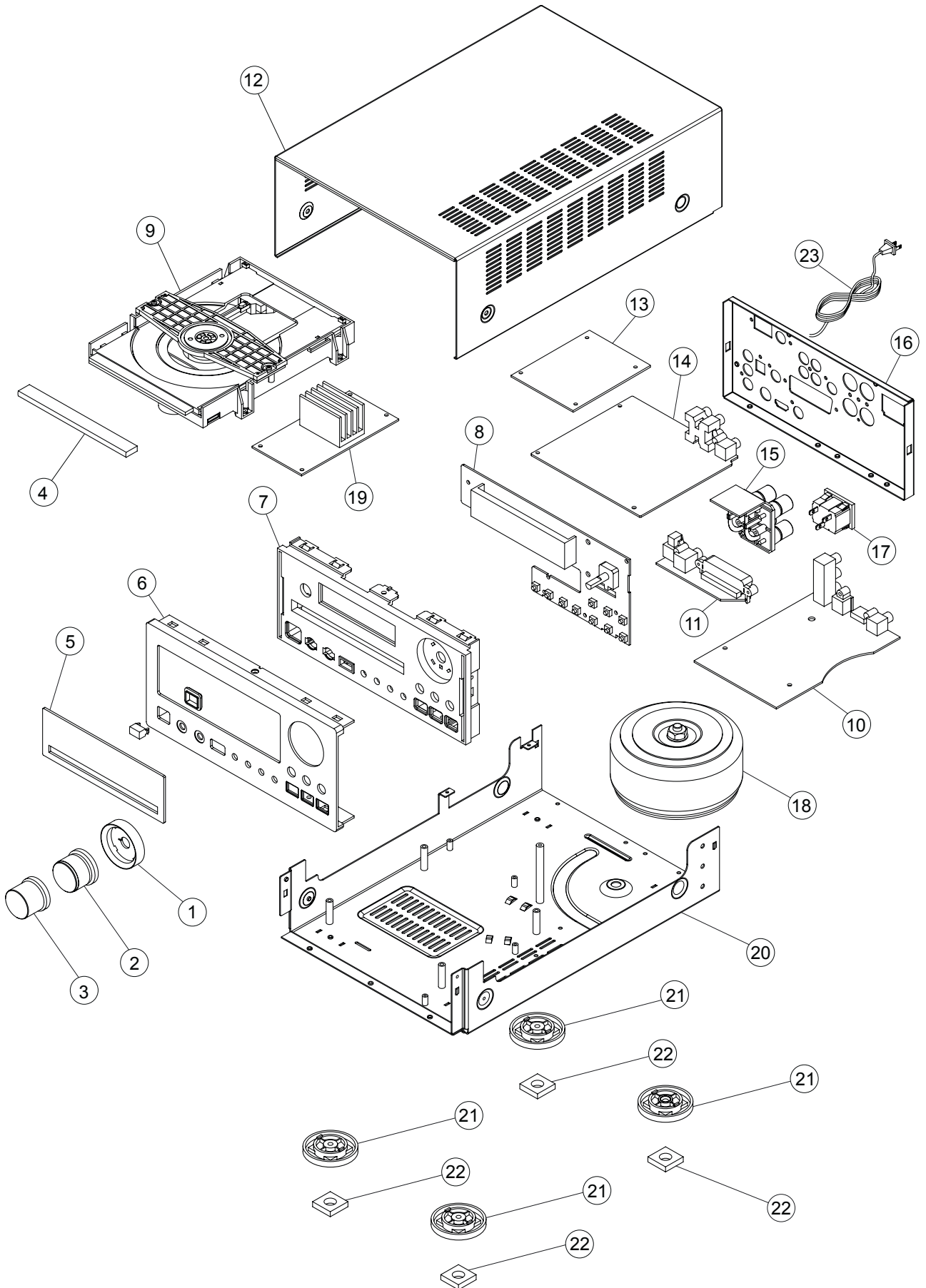

DR-H300DAB

EXPLODED VIEW-1

REF. NO	PARTS NO.	DESCRIPTION	REMARKS
1-1	39-DRH300-07A101	VOLUME KNOB RING	
1-2	39-DRH300-06A100	VOLUME KNOB	
1-3	37-DRH300-02A101B	VOLUME KNOB (ALUM.) - BLACK	
	37-DRH300-02A101S	VOLUME KNOB (ALUM.) - SILVER	
1-4	39-DRH300-01A101B	DVD DOOR - BLACK	
	39-DRH300-01A101S	DVD DOOR - SILVER	
1-5	39-DRH300-13A101	LENS	
1-6	37-DRH300-01A103B	CABINET FRONT (DURALUMIN) - BLACK	
	37-DRH300-01A103S	CABINET FRONT (DURALUMIN) - SILVER	
1-7	39-DRH300-02A101B	CABINET FRONT - BLACK	
	39-DRH300-02A101S	CABINET FRONT - SILVER	
1-8	07-DRH300D-06A101	KEY PCB ASSY	
1-9	31000085 31000043	DVD DV-33 & DVD MECHANISM BRK	
1-10	04-DRH300D-02A101	DVD DECODE CARD ASSY	
1-11	07-DRH300-09A101	USB SCART PCB ASSY	
1-12	37-DRH300-05A101B	CABINET TOP - BLACK	
	37-DRH300-05A101S	CABINET TOP - SILVER	
1-13	07-DRH300D-04A101	DAB CONNECTOR PCB ASSY	
1-14	07-DRH300D-02A101	CPU PCB ASSY	
1-15	07-DRH300-07A101	SPEAKER OUTPUT PCB ASSY	
1-16	37-DRH300-08A101	CABINET BACK	
1-17	24000359	AC SOCKET 15A/250V	
1-18	 11000222	TRANSFORMER	
1-19	07-DRH300-03A101	AMP PCB ASSY	
1-20	37-DRH300-03A100	CABINET BOTTOM	
1-21	39-DRH300-08A101 39-DRH300-09A101	UNDERPROP FOOT 1+2	
1-22	36000824	SPONGE FOOT	
1-23	26000133V	AC LINE CORD 2M -VDE [E]	
	26000133B	AC LINE CORD 2M -BS [UK]	

DR-H300DAB

3 PC BOARDS AND PARTS LIST



DAB CONNECTOR PCB ASSY

REF. NO	PARTS NO.	DESCRIPTION	REMARKS
	07-DRH300D-04A101	DAB CONNECTOR PCB ASSY	
	35-DRH300D-04A1	CONNECTOR PCB	
CN402	25000053	PIN CONNECTOR 2MM 9PIN	
DAB1122	32000314	DAB TUNER PCB GYRO-1122-I2C	
IC401,402	19000001	CHIP IC - AMC1117-0333J	
IC403	19000362	IC - 74AHC1G14	
IC404	19000087	IC - PT2579-SN	
IC405	19000361	IC - CPLDXC9536XL	
Q403,404	17000009	CRYSTAL 4.332MHZ	
X201	22000027	CHIP TR - 9014	
ZD401	16000068	ZENER DIODE 5.1V	

OPTICAL TERMINAL PCB ASSY

REF. NO	PARTS NO.	DESCRIPTION	REMARKS
	07-DRH300-08A101	OPTICAL TERMINAL PCB ASSY	
	35-DRH300-08A1	OPTICAL TERMINAL PCB	
CN801	25000973	PIN CONNECTOR 2MM 13PIN	
JACK801	24000219	SINGLE RCA SOCKET - ORANGE	
JACK802	24000349	OPTICAL DIGITAL JACK GQ-04	
J801	25001450	SCART 21PIN SOCKET	

ECO POWER PCB ASSY

REF. NO	PARTS NO.	DESCRIPTION	REMARKS
	07-DRH300-01A101	ECO POWER PCB ASSY	
	35-DRH300-01A1	POWER PCB	
CN101	25000025	PIN CONNECTOR 2MM 4PIN	
CN102,103	25001581	PIN SOCKET 3.95MM 3PIN	
F101	 26000002	FUSE F2AL250V	
REL1201	34000012	RELAY 10A240V-30VDC	
T2201	 11000080	TRANSFORMER ECO-394	

DR-H300DAB

DAB CONNECTOR PCB

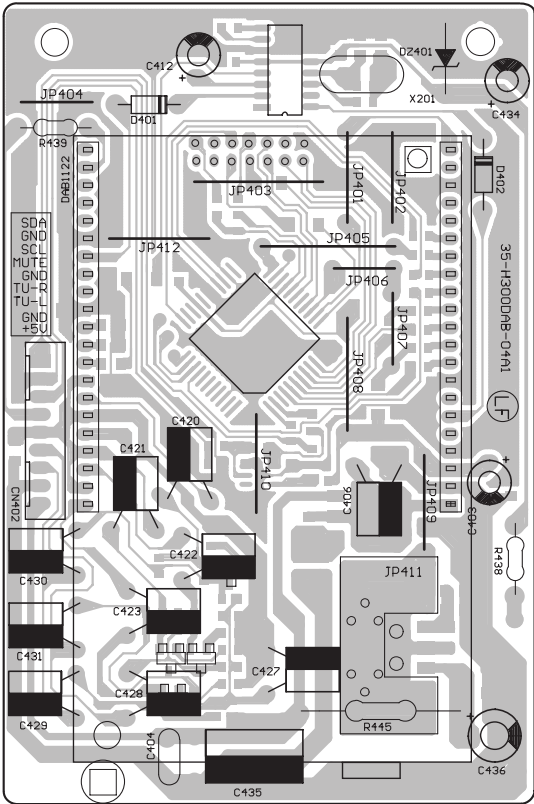

OPTICAL TERMINAL PCB

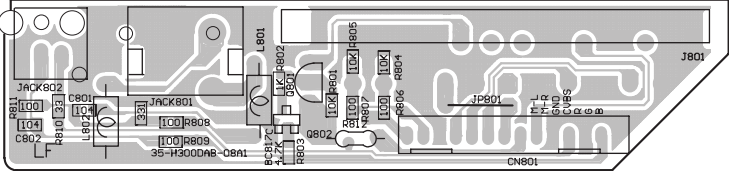

ECO POWER PCB

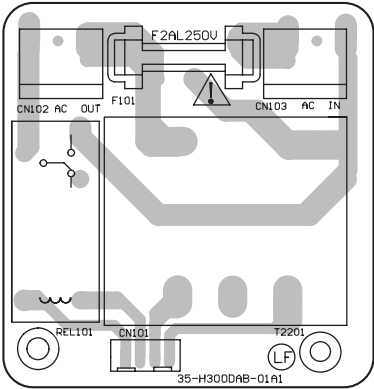

DR-H300DAB

CPU PCB ASSY

REF. NO	PARTS NO.	DESCRIPTION	REMARKS
	07-DRH300D-02A101	CPU PCB ASSY	
	35-DRH300D-02A1	CPU PCB	
BD201	18000009	THYRISTOR - RS808	
C259	⚠ 14000358	E.CAP 4700UF/25V	
CN201	25000065	PINS CONNECTOR 2MM 14PIN	
CN202	25000034	PIN CONNECTOR 2MM 5PIN	
CN203,209,210	25000025	PIN CONNECTOR 2MM 4PIN	
CN204	25000044	PIN CONNECTOR 2MM 7PIN	
CN206,212	25000053	PIN CONNECTOR 2MM 9PIN	
CN207	25000046	PIN CONNECTOR 2.5MM 7PIN	
CN208	25000016	PIN CONNECTOR 2.5MM 3PIN	
CN211	25000014	PIN CONNECTOR 2MM 3PIN	
D201,203,206,	16000104	DIODE 4001	
D207,208,218,219			
D205,212,216,217	16000018	DIODE 4148	
D211,214,215	16000128	CHIP DIODE 4148	
D213	16000115	DIODE 1N60	
DZ201	16000056	ZENER DIODE 3V	
DZ202	16000070	ZENER DIODE 5.6V	
F201	⚠ 26000002	FUSE F2AL250V	
F202,203	⚠ 26000083	FUSE F1A/125V	
IC201,203	19000103	IC - LM7805	
IC204	19000071	IC - AT24C02-PC27	
IC205	19000079	IC - PT2314	
IC206	19000075	IC - PT2309-S	
IC207	19000108	IC - 7808	
JACK201	24000080	RCA SOCKET 4PIN	
JACK203	24000115	SINGLE RCA SOCKET	
L201	15000005	FIXED INDUCTOR 10U	
L203	33000038	FERRITE BEAD GBG0805 2.2K	
Q201	17000004	CHIP TR - 8050	
Q202	17000013	TR - 2SB772A	
Q203	17000034	TR - 9014C	
Q204	17000009	CHIP TR - 9014	
Q205,206	17000030	TR - 8550C	
Q207-209	17000025	TR - 8050C	
Q210	17000049	CHIP RESISTOR BC847B	
X202	22000018	CER.FILTER 4.19MHZ	
X203	22000021	CRYSTAL 32.768KHZ	
ZD203	16-000077	ZENER DIODE 9.1V	

DR-H300DAB

CPU PCB

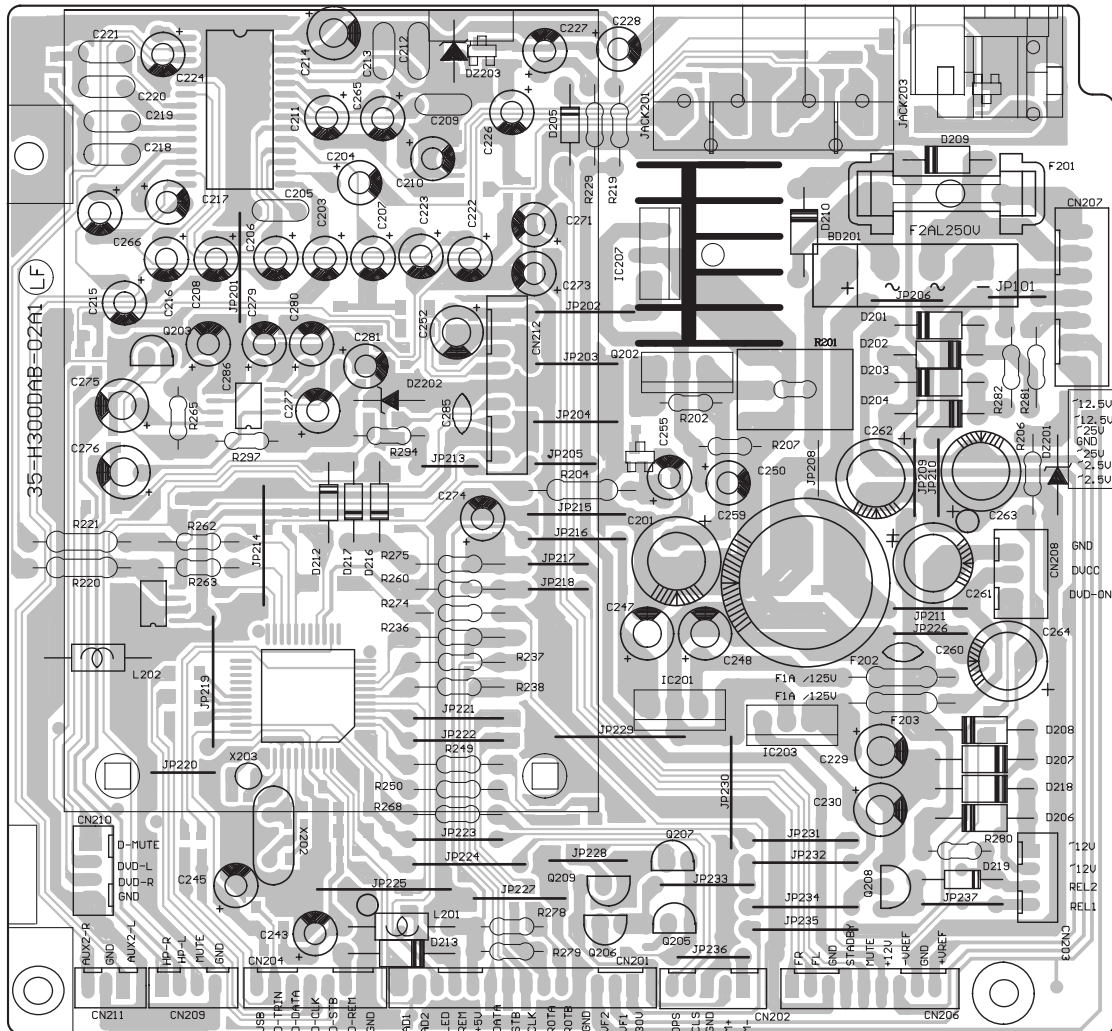

DR-H300DAB

AMP PCB ASSY

REF. NO	PARTS NO.	DESCRIPTION	REMARKS
	07-DRH300-03A101	AMP PCB ASSY	
	35-DRH300-03AI	AMP PCB	
BD301	18000009	THYRISTOR - RS808	
C332,333	⚠ 14000361	E.CAP 4700UF/35V	
CN301	25000020	PIN SOCKET 3.95MM 3PIN	
CN302	25000053	PIN CONNECTOR 2MM 9PIN	
CN305	25000029	PIN CONNECTOR 2.5MM 4PIN	
DZ301	16000070	ZENER DIODE 5.6V	
F301,302	⚠ 26000009	FUSE F6.3AL250V	
IC302	19000112	IC - 7812	
IC303	19000120	IC - TDA8920	
L302,313	15000019	FIXED INDUCTOR 22U	
L305,310	33000017	FERRITE BEAD JRHW0349 -BLUE	
Q301,309	17000005	CHIP TR - BC817-25	
Q302	17000013	TR - 2SB772A	

HEADPHONE PCB ASSY

REF. NO	PARTS NO.	DESCRIPTION	REMARKS
	07-DRH300-05A101	HEADPHONE PCB ASSY	
	35-DRH300-05A1	HEADPHONE PCB	
CN501	25000014	PIN CONNECTOR 2MM 3PIN	
CN502	25000025	PIN CONNECTOR 2MM 4PIN	
JACK202	24000177	HEADPHONE SOCKET #TE-03501S-05	
J104	24000120	HEADPHONE SOCKET #TE-03501S-11	

USB SCART PCB ASSY

REF. NO	PARTS NO.	DESCRIPTION	REMARKS
	07-DRH300-09A101	USB SCART PCB ASSY	
	35-DRH300-09A1	USB SCART PCB	
CN901	25000025	PINS CONNECTOR 2MM 4PIN	
JACK901	24000351	USB A-TYPE 4PIN	

SPEAKER OUTPUT PCB ASSY

REF. NO	PARTS NO.	DESCRIPTION	REMARKS
	07-DRH300-07A101	SPEAKER OUTPUT PCB ASSY	
	35-DRH300-07A1	SPEAKER PCB	
CN701	25000029	PINS CONNECTOR 2.5MM 4PIN	
SPK701	24000288	SPEAKER SOCKET 4PIN	

DR-H300DAB

AMP PCB - TOP

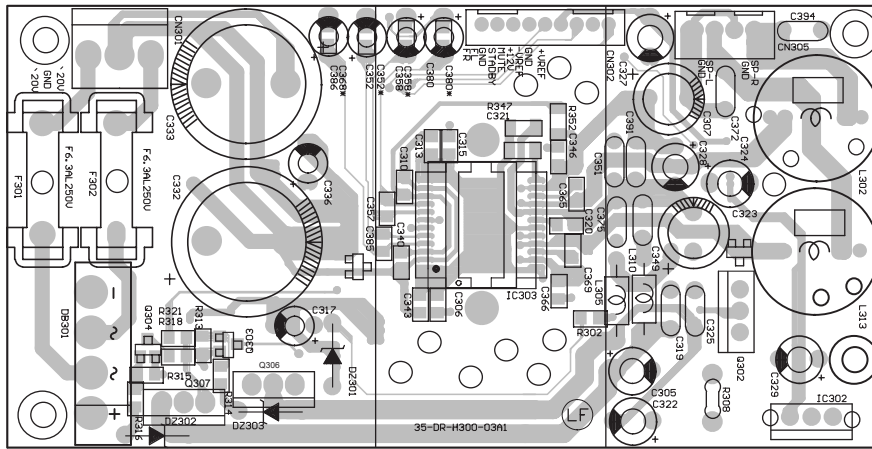

AMP PCB - BOTTOM

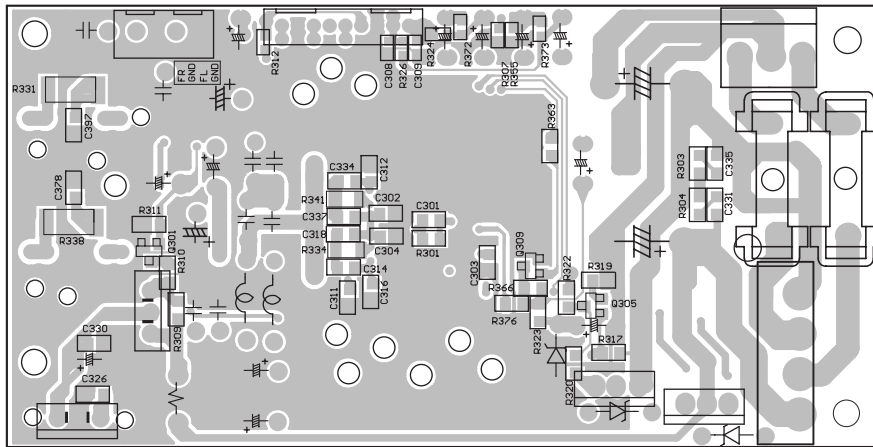

HEADPHONE PCB

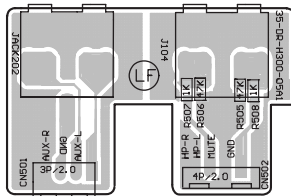

USB SCART PCB

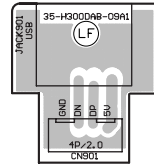

SPEAKER OUTPUT PCB

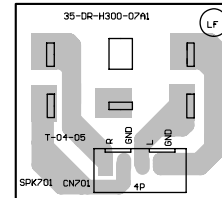

DR-H300DAB

KEY PCB ASSY

REF. NO	PARTS NO.	DESCRIPTION	REMARKS
	07-DRH300D-06A101	KEY PCB ASSY	
	35-DRH300D-06A1	PUSH KEY PCB	
CN601	25000071	PIN CONNECTOR 2.54MM 17PIN	
CN603,604	25000025	PIN CONNECTOR 2MM 4PIN	
ENCODER301	30000004	CODER ED1612-24T1-00HC-F20	
LED601	16000028	LED DIODE 3MM - ORANGE	
S301	21000026	IR SENSOR STM-404TN	
SW601-609,611	23000032	LIGHT TOUCH SWITCH - 6X6X5MM	
SW612			

DAB DISPLAY PCB ASSY

REF. NO	PARTS NO.	DESCRIPTION	REMARKS
	07-NE1204D2-38A101	DAB DISPLAY PCB ASSY	
	35-NE1204D2-38A1	PANEL PCB	
IC2	19000090	IC - PT6314	
VFD1	29000238	VFD DISPLAY #16T-202	

DR-H300DAB

KEY PCB

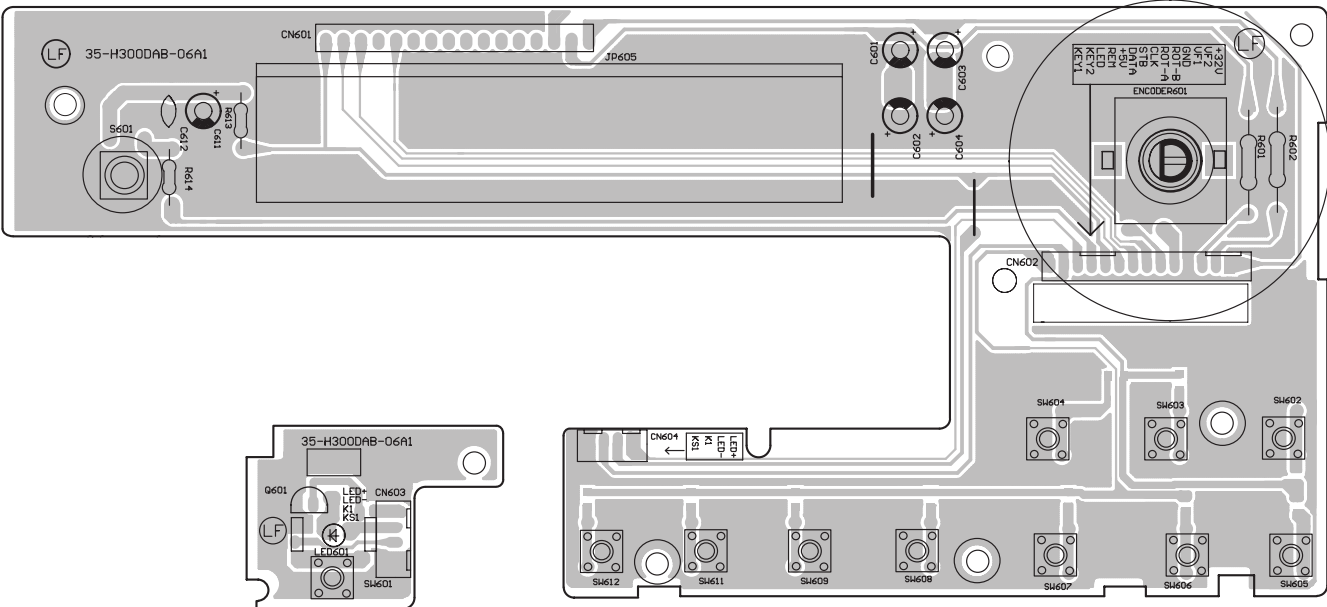

DAB DISPLAY PCB - TOP

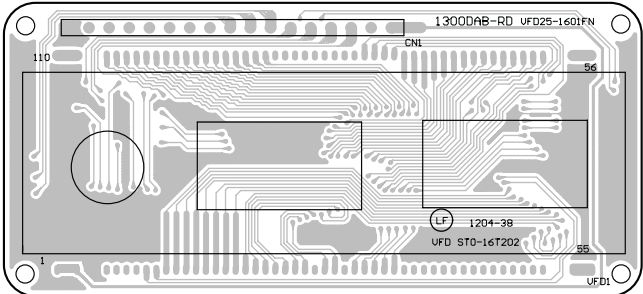

DAB DISPLAY PCB - BOTTOM

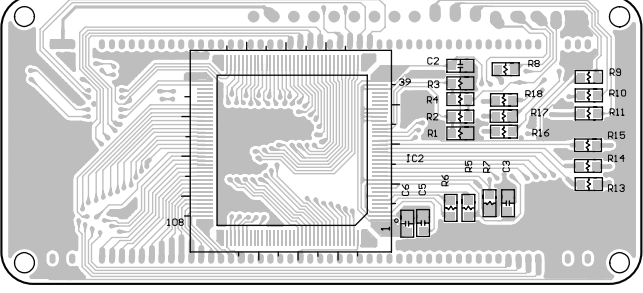

DR-H300DAB

DVD DECODER CARD ASSY

REF. NO	PARTS NO.	DESCRIPTION	REMARKS
	04-DRH300D-02A101	DVD DECODER CARD ASSY	

DVD DECODER CARD

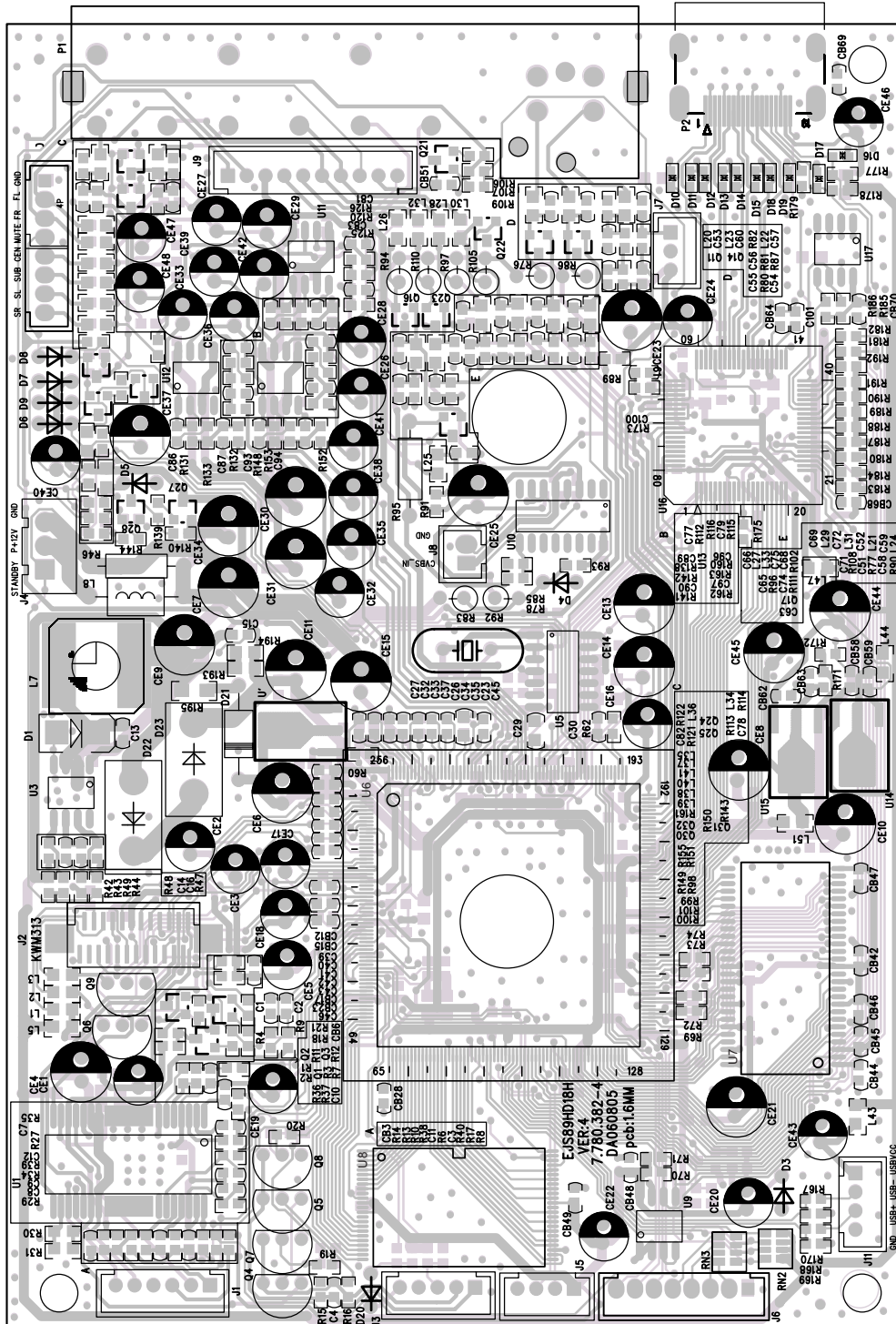

DR-H300DAB

4 WIRING DIAGRAM

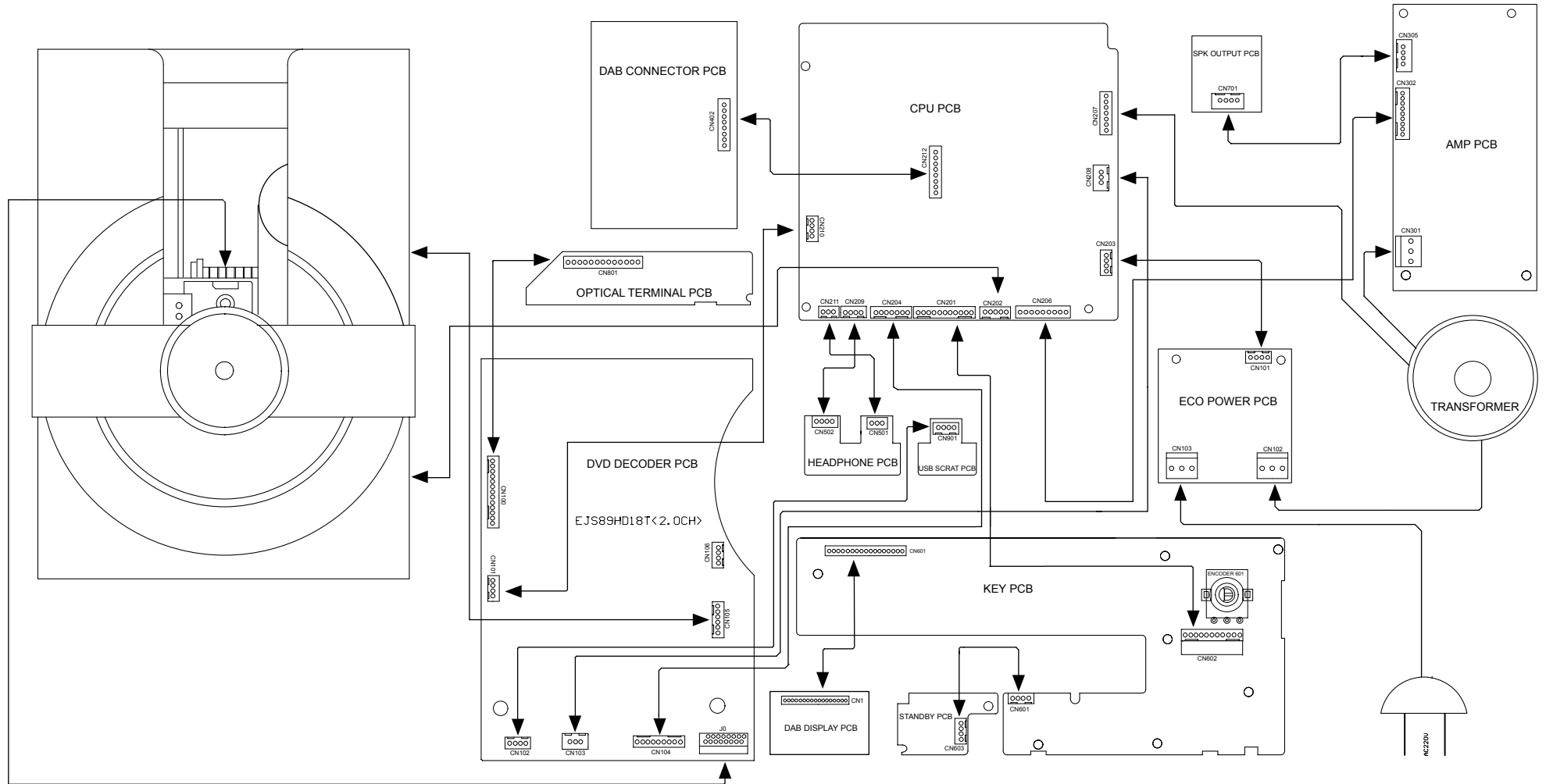

DR-H300DAB

5 INCLUDED ACCESSORIES

INCLUDED ACCESSORIES

REF. NO	PARTS NO.	DESCRIPTION	REMARKS
	41004173	INSTRUCTION BOOK - E	
	34000005	AAA BATTERY 1.5V	
	27000043	AUDIO SINGLE WIRE W/RCA PLUG - YELLOW	
	32000288B	REMOTE HANDSET - BLACK (RC1117)	
	32000288S	REMOTE HANDSET - SILVER (RC1116)	
	37000920	DAB ANTENNA SPEC 1.8M	

DR-H300DAB

TEAC

TEAC CORPORATION	3-7-3 Nakacho, Musashino-shi, Tokyo 180-8550, Japan Phone:(0422)52-5081
TEAC AMERICA, INC.	7733 Telegraph Road, Montebello, California 90640 Phone: (323)726-0303
TEAC CANADA LTD.	5939 Wallace Street, Mississauga, Ontario L4Z 1Z8, Canada Phone: (905)-890-8008
TEAC MEXICO, S.A.De C.V.	Campesinos N°184, Colonia.Granjas Esmeralda, Delegacion Iztapalapa,CP 09810,Mexico DF Phone: (525)-581-5500
TEAC UK LIMITED	Unit 19 & 20, The Courtyards, Hatters Lane, Watford, Hertfordshire, WD18 8TE5, U.K. Phone:(0845) 130-2511
TEAC EUROPE GmbH	Bahnstrasse 12, 65205 Wiesbaden-Erbenheim, Germany Phone: 0611-71580
TEAC ITALIANA S.p.A.	Via C, Cantu 9/A, 20092 Cinisello Balsamo, Milano, Italy Phone:02-66010550
TEAC AUSTRALIA PTY., LTD.	280 William Street, Melbourne VIC 3000, Australia Phone:(03)9672-2400
A.B.N. 80 005 408 462	

JUNE 2007

PREPARED IN HONG KONG

DAB CONNECTOR PCB

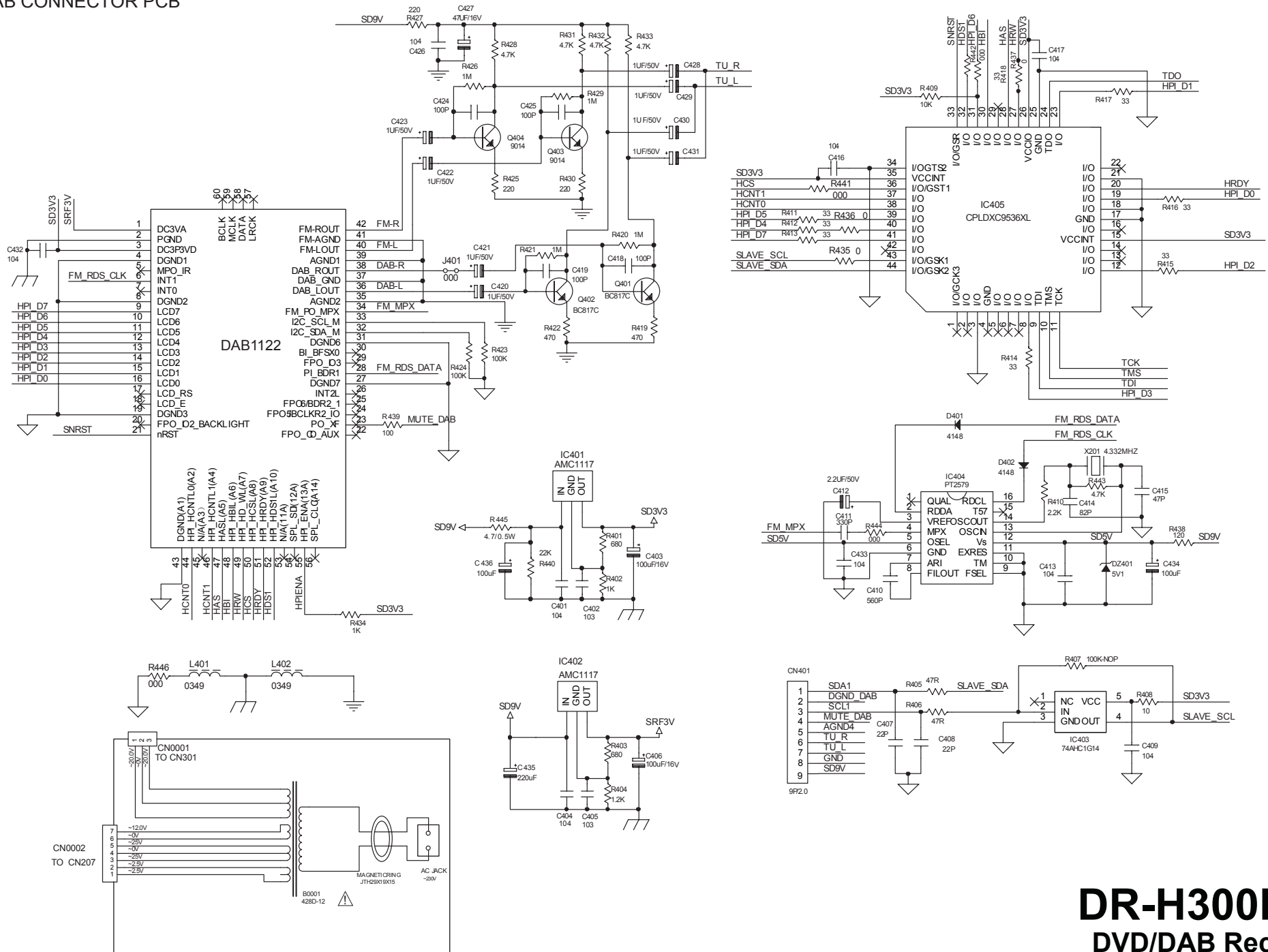

DR-H300DAB
DVD/DAB Receiver

DAB TUNER PCB

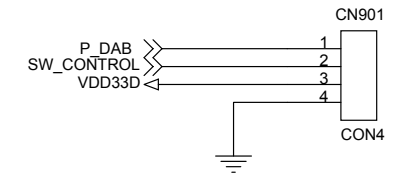
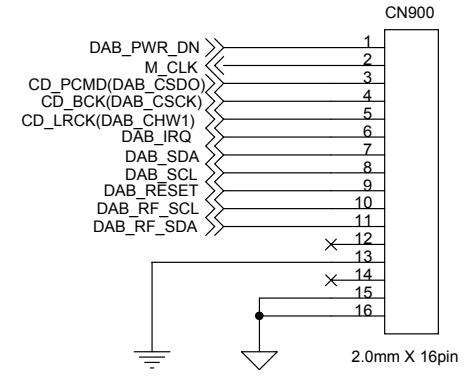
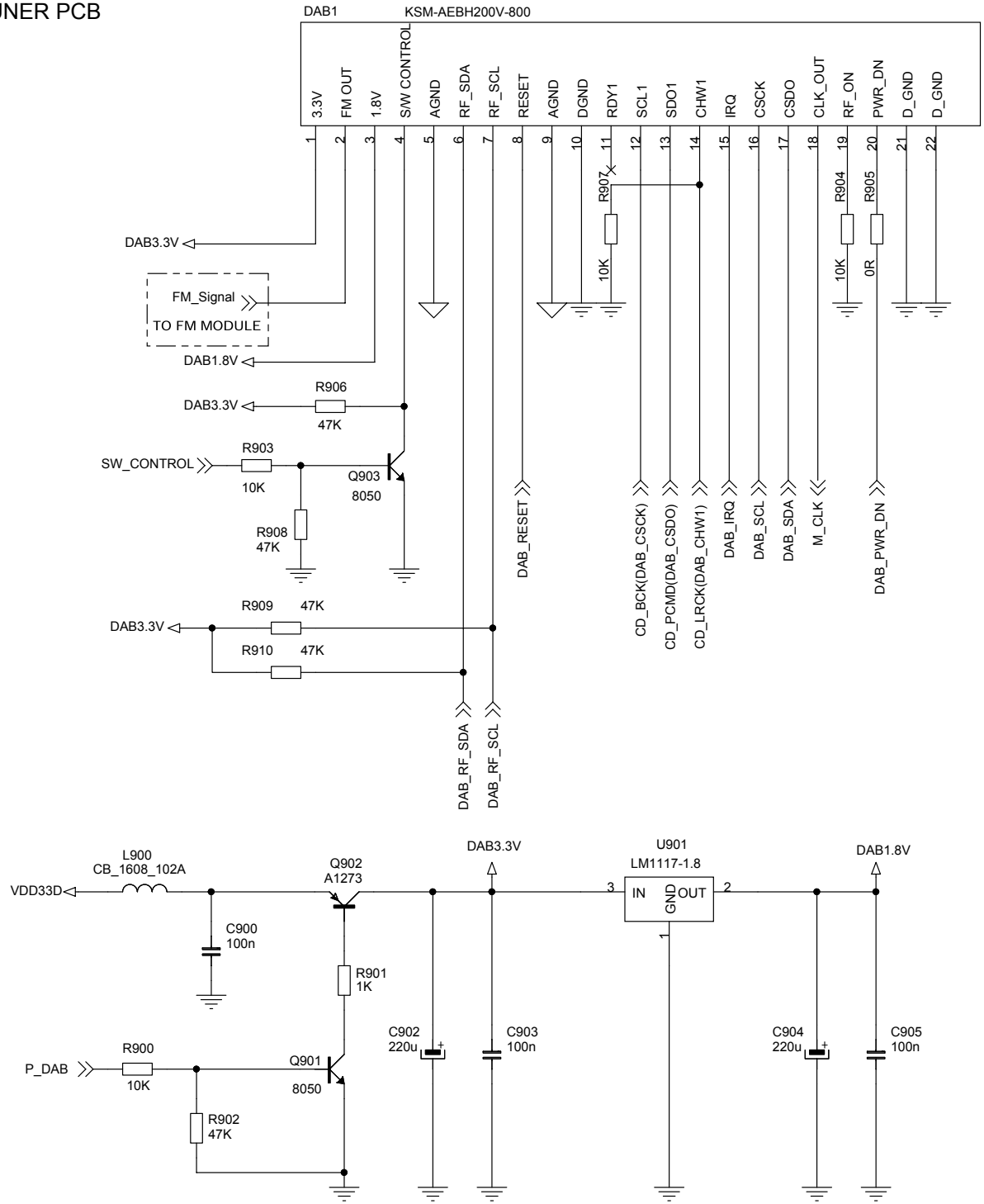

DR-H300DAB
DVD/DAB Receiver

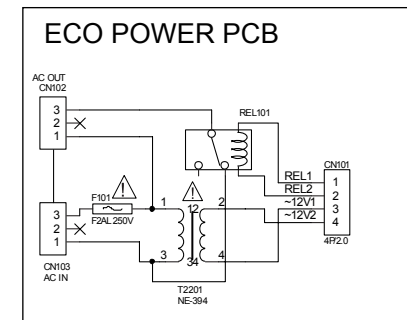
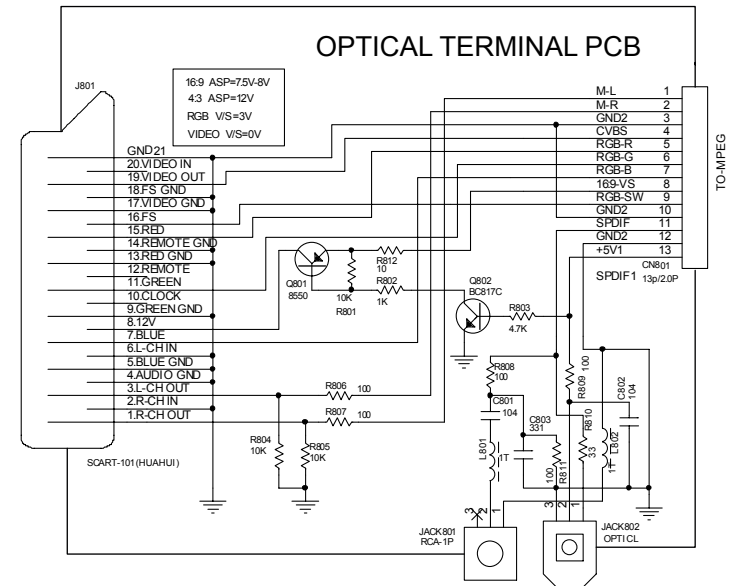
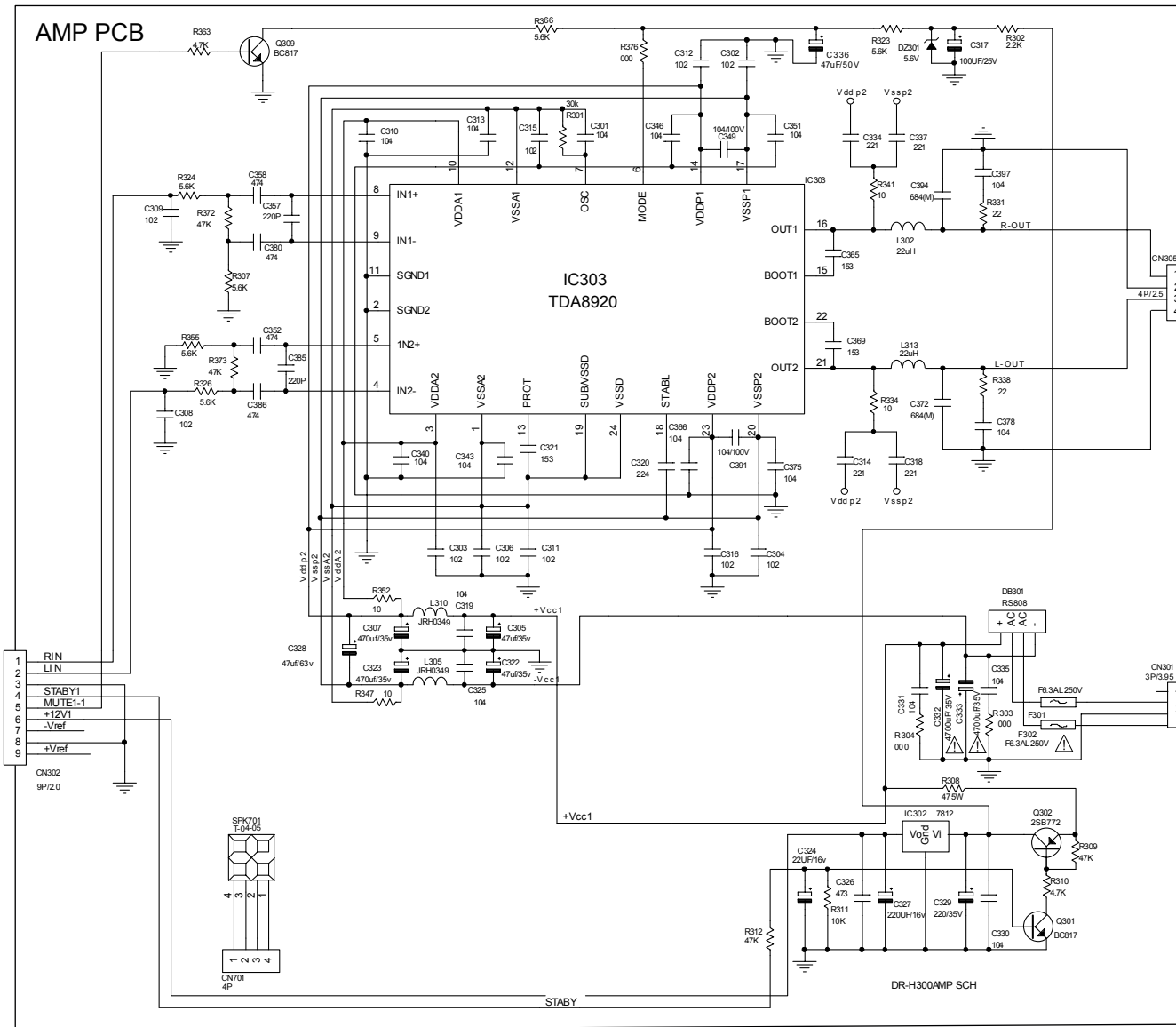

DR-H300DAB
DVD/DAB Receiver

DAB DISPLAY PCB

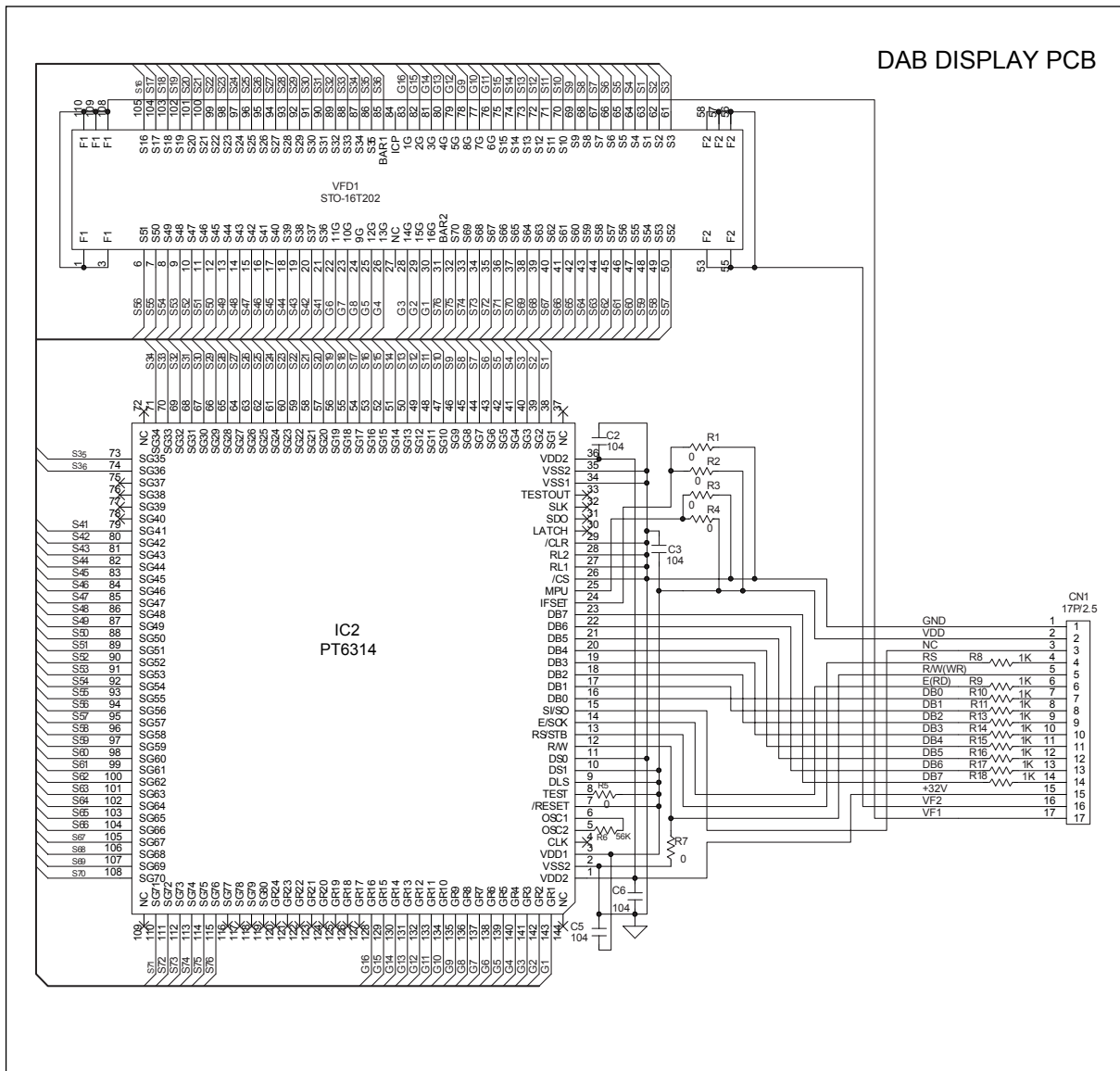

KEY PCB

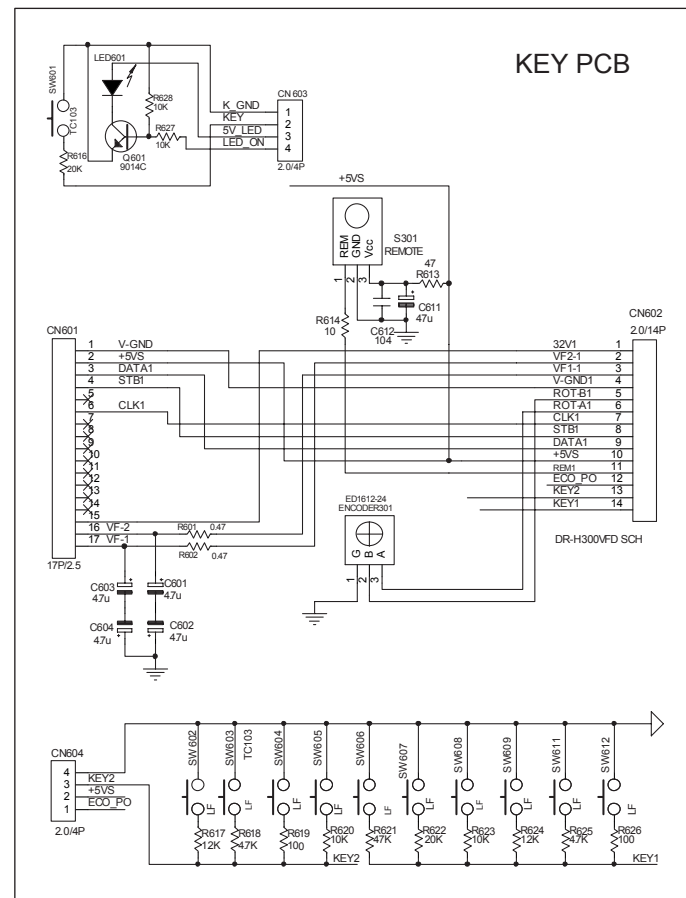

DR-H300DAB

DVD/DAB Receiver

DVD DECODE PCB - 1

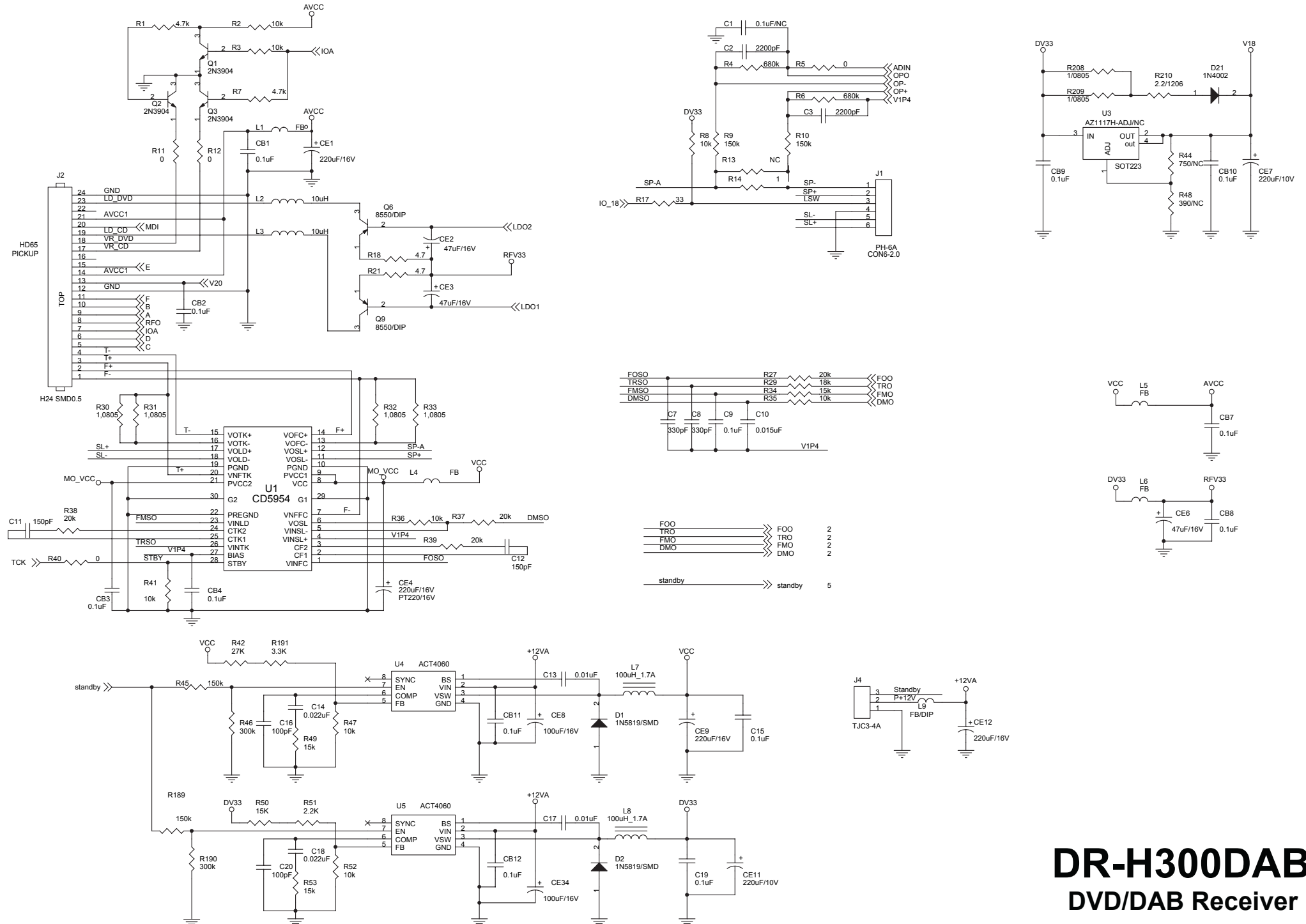

DR-H300DAB
DVD/DAB Receiver

DVD DECODE PCB-2

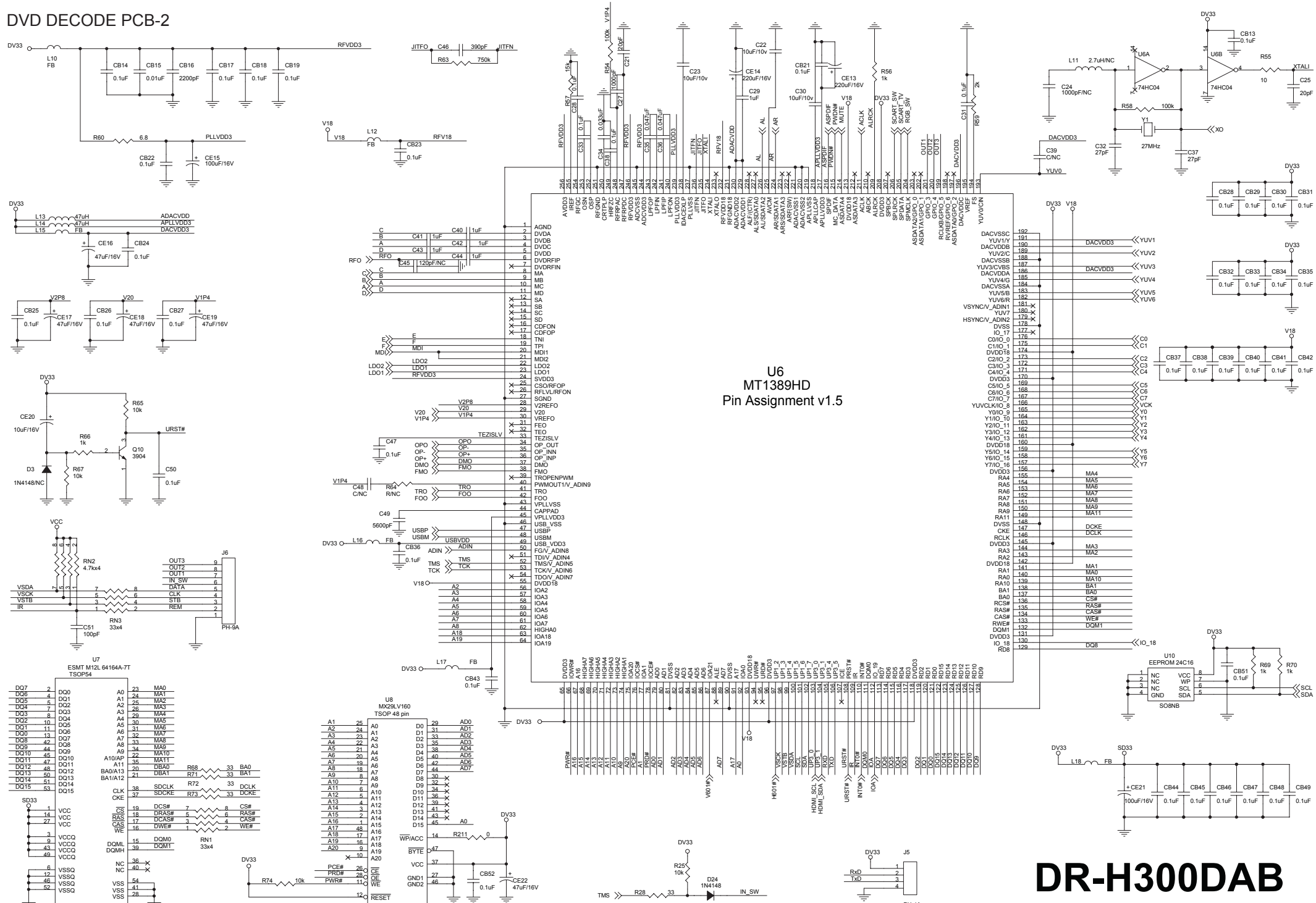

U6
MT1389HD
Pin Assignment v1.5

DR-H300DAB DVD/DAB Receiver

DVD DECODE PCB-3

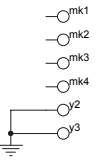
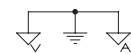
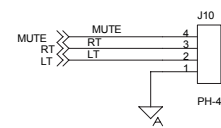
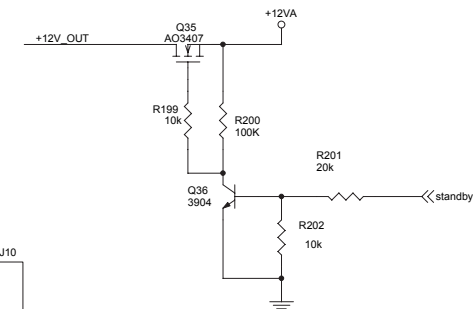
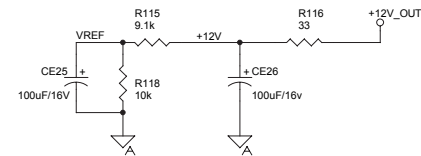
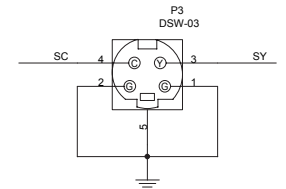
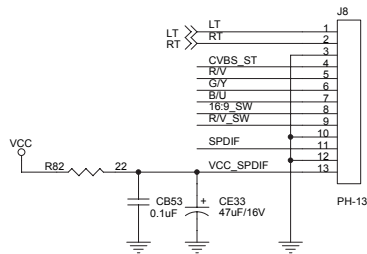
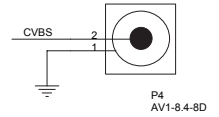
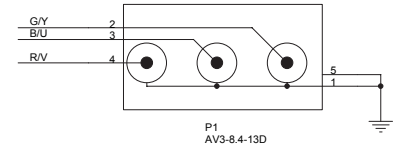
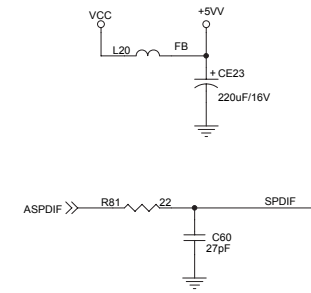
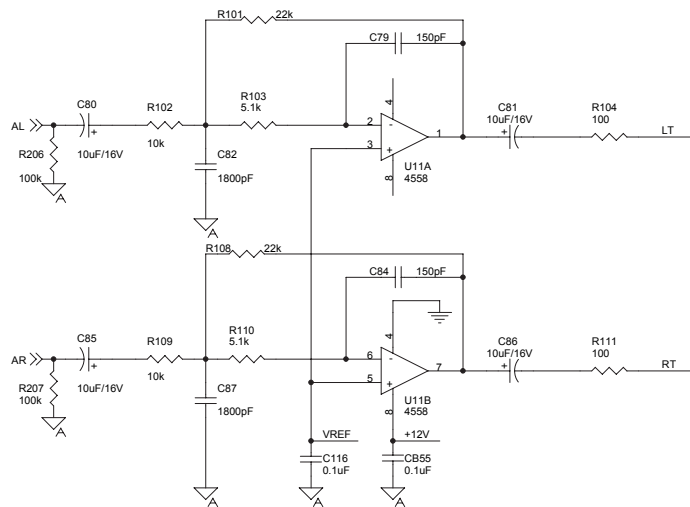
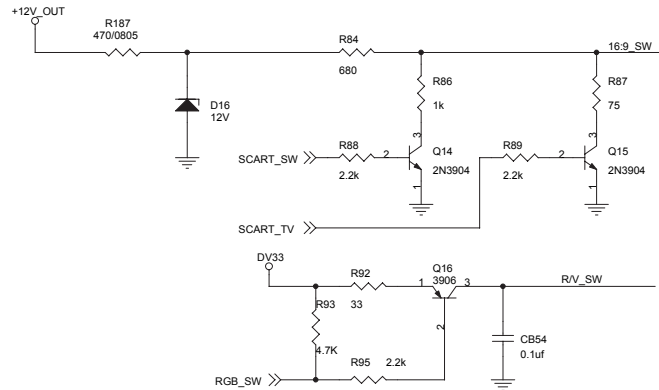
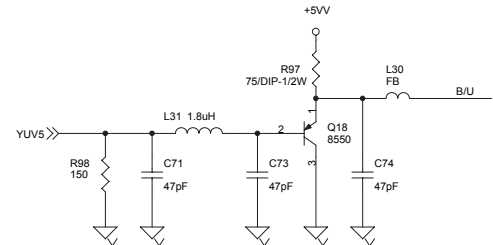
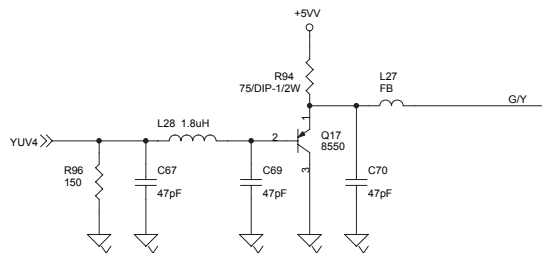
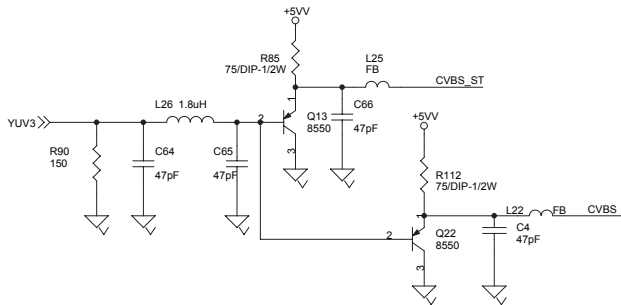
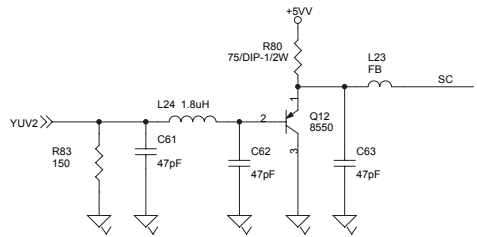
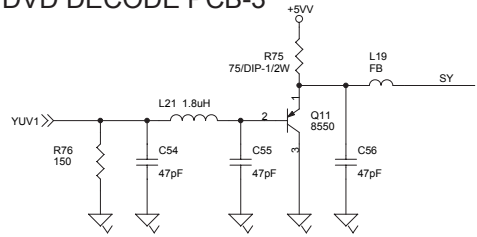

DR-H300DAB DVD/DAB Receiver

DVD DECODE PCB - 4

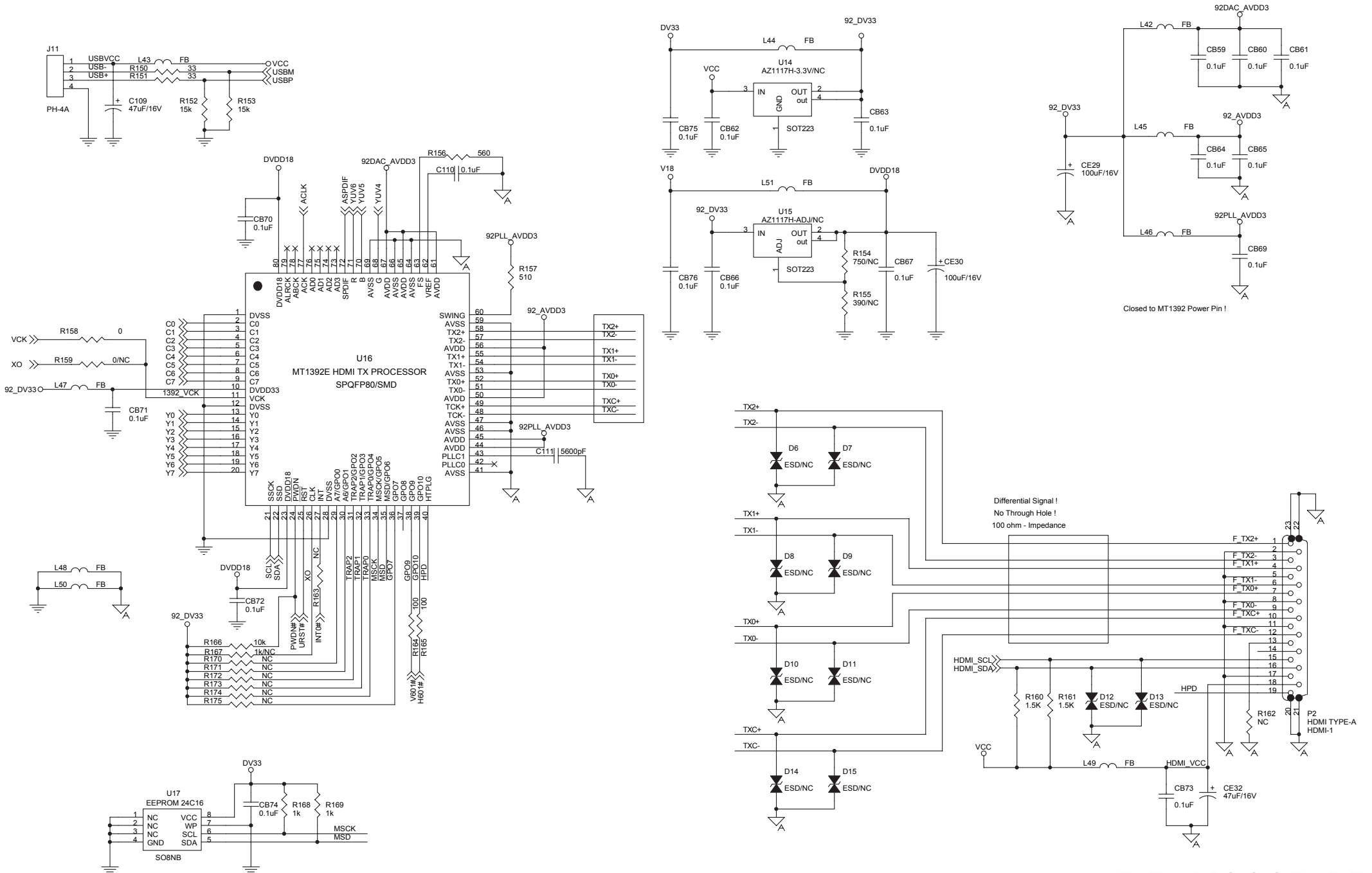

DR-H300DAB DVD/DAB Receiver