

ICEpower a/s, Gl. Lundtoftevej 1b, DK-2800 Kgs. Lyngby  
Phone [45] 96 84 11 22, Fax [45] 96 84 57 99, CVR-no. 25053591  
info@icepower.dk, www.icepower.dk

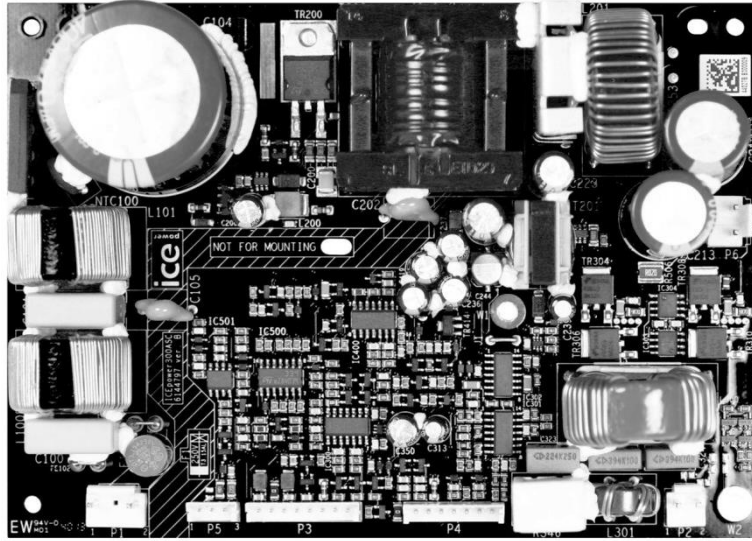

# ICEpower300ASC

300W ICEpower Amplifier with Integrated Power Supply

Data Sheet

Version 1.2

## Contents

---

General Description .....	3
Release Notes .....	4
Block Diagram .....	5
Absolute Maximum Ratings .....	9
Power Specifications .....	10
Audio Specifications.....	11
General Audio Specifications .....	13
Electrical Specifications .....	15
Timing Specifications.....	15
Mechanical Specifications .....	16
Other Environmental Testing.....	16
Typical Performance Characteristics .....	17
Output Impedance .....	21
Damping Factor .....	21
Dissipated Power .....	23
Input/Output Schematics and Features .....	24
Operational Timing Diagram .....	28
Protection Features .....	31
Physical Dimensions.....	33
Safety Standards .....	35
EMI Standards.....	35
ESD Warning .....	36
Packaging and Storing .....	36
Further Information .....	37

## General Description

300ASC combines a high performance class D amplifier with a universal mains switch mode power supply with standby functionality, auxiliary power supplies, wake on signal sense, 5V and 12V triggers, status LED indicators and a DC-bus output for powering a 300AC amplifier. Basically everything needed for a subwoofer, an active loudspeaker or a high-end amplifier. Key benefits include:

- ICEpower's patented HCOM modulation and control techniques ensure excellent audio performance
- Integrated ICEpower supply with separate AUX converter and standby functionality makes for a compact, turnkey power solution
- A comprehensive set of features for plug-and-play implementation in a wide range of applications such as active speakers, subwoofers, HTIB, and A/V amplifiers and receivers
- Fully backwards compatible with the ICEpower200ASC module (same dimensions, mounting holes and connectors)
- Compliance with 2013 regulatory standby requirements 1275/2008/EC step II and Energy Star® with 0.275W@230V<sub>AC</sub> standby current consumption with no payload

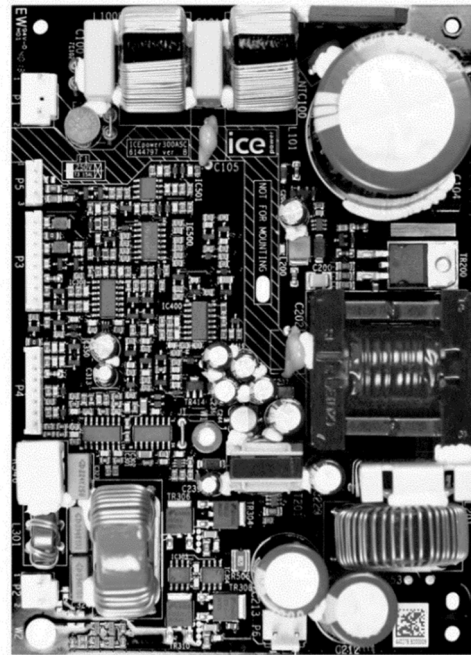

## Key Specifications

- 300W at 1% THD+N, 40hm
- 260W at 0.1% THD+N, 40hm
- 380W at 10% THD+N, 40hm
- 450W at 1% THD+N, 2.70hm
- Full power bandwidth (20Hz – 20kHz)
- 113dBA dynamic range (300W, 40hm)
- THD+N = 0.005% (1W, 40hm)
- Audio input impedance 47kOhm (fully balanced)
- High output current limit = 20A<sub>p</sub>
- Low output impedance = 6mOhm
- Damping factor = 660, 40hm
- Total power efficiency 80% (AC mains to Audio Out)
- Standby power consumption 0.275W@230 V<sub>AC</sub>

## Key features

- Rugged construction
- Suitable for CE and FCC approved designs
- ±12V and +5V auxiliary DC output and +5V standby aux
- Universal mains 85-264V<sub>AC</sub>
- 5V and 12V triggers plus signal sense with auto standby
- Thermal protection
- Over current and short circuit protection
- DC output protection
- DC servo for low DC offset
- EMI conforms to: EN55013 and others
- Safety conforms to: UL60065 and others

## Release Notes

PCB Version	Data Sheet Version	Date	Revised by	Description
C	1.0	24 June 2014	MGA/SMK	Release version
C	1.1	11 August 2014	MPS/SMK	Minor corrections
C	1.2	28 January 2014	LBH/KOU	Minor additions

Table 1: Release notes

### Block Diagram

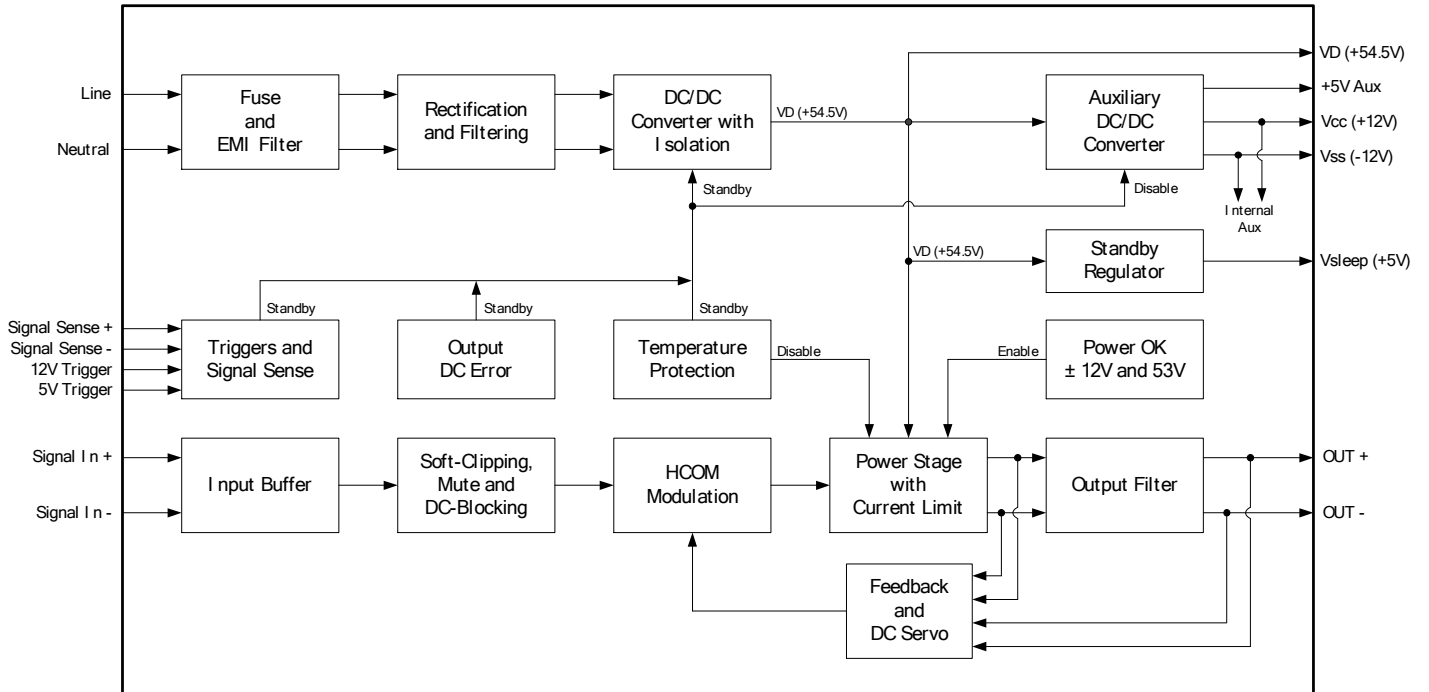

Figure 1: ICEpower300ASC block diagram

Connection Diagram

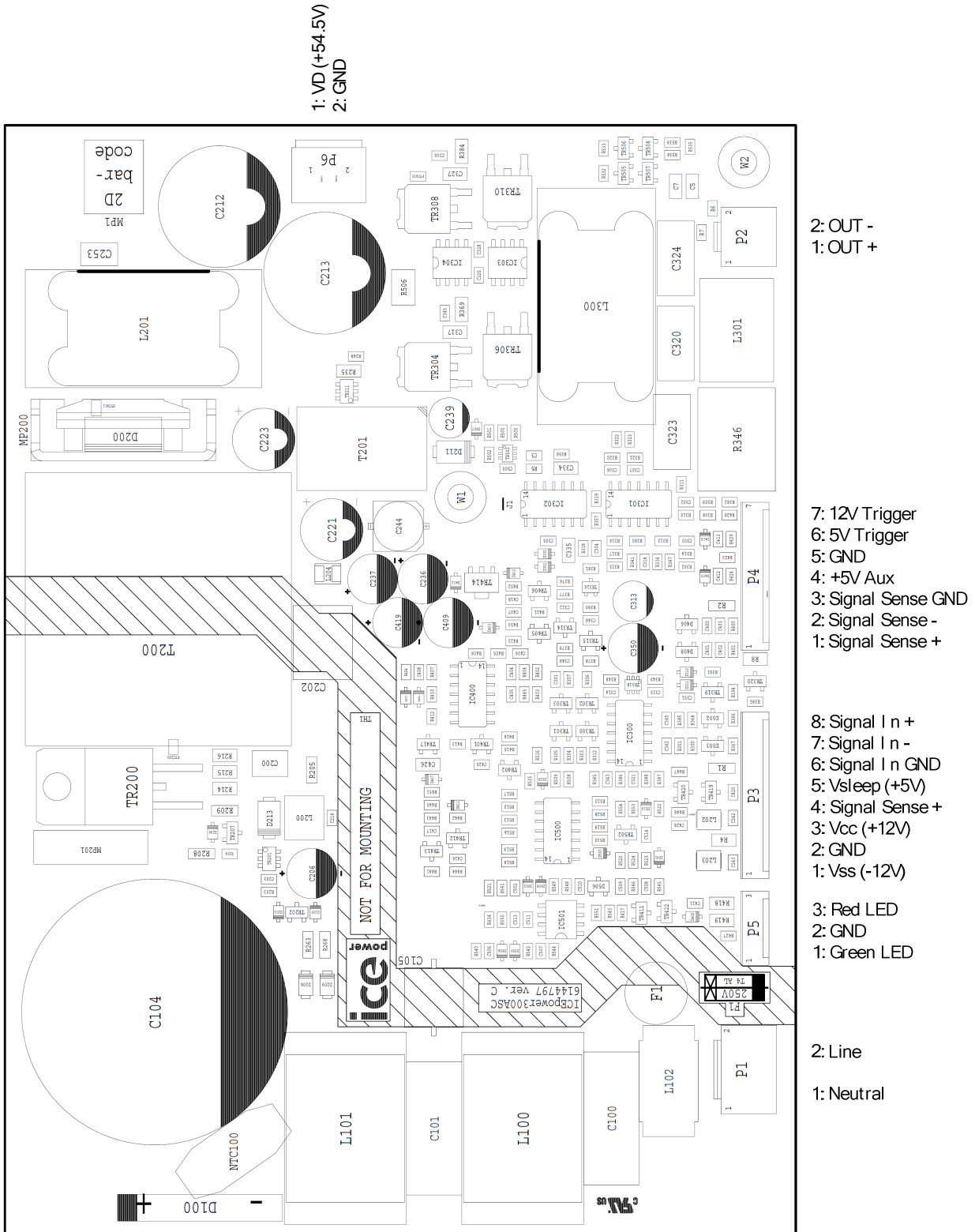

Figure 2: ICEpower300ASC connections

The plug interface of the ICEpower300ASC modules has six industry standard connectors selected for long-term reliability.

#### AC Header Specification (P1)

Type: JST B 3P(1,3)-VH			
PIN	Function	Description	Type
1	Neutral	Mains AC Neutral	Input
2	Line	Mains AC Line	Input

Table 2: AC connector specifications

#### Speaker Header Specification (P2)

Type: JST B 2P-VH			
PIN	Function	Description	Type
1	OUT+	Positive balanced audio power output terminal	Output
2	OUT-	Negative balanced audio power output terminal	Output

Table 3: Speaker connector specifications

#### Signal Header Specification (P3)

Type: JST B8B-EH-A			
PIN	Function	Description	Type
1	Vss (-12V)	Power supply -12V	Output
2	GND	Ground terminal for the auxiliary voltages	GND
3	Vcc (+12V)	Power supply +12V	Output
4	Signal Sense +	Startup via signal sense	Input
5	Vsleep (+5V)	Low power standby supply	Output
6	Signal GND	Ground terminal for the input signal	GND
7	Signal In -	Negative input (full balanced input buffer)	Audio Input
8	Signal In +	Positive input (full balanced input buffer)	Audio Input

Table 4: Signal In connector specifications

## Signal Header Specification (P4)

Type: JST B7B-EH-A			
PIN	Function	Description	Type
1	Signal Sense +	Balanced positive signal sense	Input
2	Signal Sense -	Balanced negative signal sense	Input
3	Signal Sense GND	Ground terminal for the signal sense section.	GND
4	+5V Aux	Power supply +5V	Output
5	GND	Ground terminal for triggers and auxiliary voltage	GND
6	5V Trigger	5V trigger for startup	Input
7	12V Trigger	12V trigger for startup	Input

Table 5: Signal Sense and Trigger Connector specifications

## LED Output Header Specification (P5)

Type: JST B3B-EH-A			
PIN	Function	Description	Type
1	Green LED	LED drive for on indicator	Output
2	GND	Ground terminal for the LED section	GND
3	Red LED	LED drive for standby and protection indicator	Output

Table 6: LED Output specification

## DC-bus Header Specification (P6)

Type: JST B 2P-NV			
PIN	Function	Description	Type
1	VD (+54.5V)	Power supply +54.5V	Output
2	GND	Ground terminal for the power section	GND

Table 7: DC bus connector specifications



## Absolute Maximum Ratings

Absolute maximum ratings indicate limits beyond which damage may occur.

### Mains Input Section

Symbol	Parameter	Value	Unit
AC <sub>max</sub>	Maximum off-line voltage	264	V <sub>AC</sub>
AC <sub>min</sub>	Minimum off-line voltage	85	V <sub>AC</sub>
F <sup>1)</sup>	Mains frequency range 85V <sub>AC</sub> - 264V <sub>AC</sub>	45 – 65	Hz

Table 8: Absolute maximum ratings mains, input section

### DC-bus

Symbol	Parameter	Value	Unit
I <sub>VD</sub> <sup>2)</sup>	Maximum current draw from V <sub>D</sub> (+54.5V)	5.5	A
P <sub>VD+Audio</sub>	Maximum total power from V <sub>D</sub> (+54.5V) and audio output combined	300	W
I <sub>+12V</sub>	Maximum current draw from V <sub>CC</sub> (+12V)	300	mA
I <sub>-12V</sub>	Maximum current draw from V <sub>SS</sub> (-12V)	200	mA
I <sub>+5V</sub>	Maximum current draw from +5V aux	1000	mA
P <sub>AUX</sub>	Maximum total power from V <sub>CC</sub> , V <sub>SS</sub> and +5V aux	8	W
I <sub>Vsleep</sub>	Maximum current draw from V <sub>sleep</sub> (+5V)	10	mA

Table 9: Absolute maximum ratings, DC-bus

2) The +54.5V output is not overcurrent protected. Exceeding the limit may permanently damage the device.

### Input Section

Symbol	Parameter	Value	Unit
V <sub>in+</sub> , V <sub>in-</sub>	Maximum voltage range on pin	±12	V
Triggers	Maximum voltage range on pin	0 - 12	V
Signal Sense	Maximum voltage range on pin	±12	V

Table 10: Absolute maximum ratings, input section

## Output Section

Symbol	Parameter	Value	Unit
$R_{load}^{3)}$	Minimum load	2.5	$\Omega$
$I_{out}^{3)}$	Maximum current draw from amplifier output	20	Ap
$C_L$	Maximum pure capacitive loading	220	nF

Table 11: Absolute maximum ratings, output section

3) The over current protection will act to protect the amplifier. (See "Protection features")

## Thermal Section

Symbol	Parameter	Value	Unit
$T_a$	Max. operating ambient temperature	60	$^{\circ}\text{C}$

Table 12: Absolute maximum ratings, thermal section

## Power Specifications

Unless otherwise specified.  $T_a=25^{\circ}\text{C}$ ,  $f=1\text{kHz}$ ,  $\text{Load}=4\Omega$ , 230V mains

Symbol	Parameter	Conditions	Min	Typ	Max	Unit
$V_D$	Nominal DC voltage	Off-line input within range	-	+54.5	-	V
+5V	Positive analog/digital supply	Off-line input within range	+5.0	+5.2	+5.6	V
Vcc	Positive analog supply	Off-line input within range	+10.4	+12	+12.9	V
Vss	Negative analog supply	Off-line input within range	-15.0	-12	-10.7	V
$t_{Pmax}$	Time of maximum rated output power	300W out, no preheating. 230Vac / 50Hz 115Vac / 60Hz 100Vac / 50Hz	- - -	60 30 27	- - -	s
$t_{P400W}$	Time of 400W output power	400W out, no preheating. Load= $2.7\Omega$ 230Vac / 50Hz 115Vac / 60Hz 100Vac / 50Hz	- - -	34 17 2	- - -	s

$P_T$	Continuous output power without thermal shutdown.	Thermal stab. at $T_a = 25^\circ\text{C}$ . Thermal stab. at $T_a = 50^\circ\text{C}$ .	- -	100 60	- -	W
$P_{FTC}$	FTC rated output power.	230V <sub>ac</sub> / 50Hz 115V <sub>ac</sub> / 60Hz	- -	140 140	- -	W
$P_q$	Quiescent power consumption	230V <sub>AC</sub> / 50Hz, $P_o = 0\text{W}$ 115V <sub>AC</sub> / 60Hz, $P_o = 0\text{W}$	- -	6.8 5.9	- -	W
$P_{stby}$	Standby power consumption	230V <sub>AC</sub> / 50Hz 115V <sub>AC</sub> / 60Hz	- -	275 225	- -	mW
$P_{stby}$	Standby power consumption with Red LED On	230V <sub>AC</sub> / 50Hz 115V <sub>AC</sub> / 60Hz	- -	275 225	- -	mW
$P_{stby}$	Standby power consumption with Red LED On and 10mA supplied by $V_{sleep}$	230V <sub>AC</sub> / 50Hz 115V <sub>AC</sub> / 60Hz	- -	- -	500 500	mW
$\eta$	Total power efficiency, 230V <sub>AC</sub> / 50Hz	$P_o = 300\text{W}$ , $R_L = 4\Omega$ $P_o = 200\text{W}$ , $R_L = 4\Omega$ $P_o = 100\text{W}$ , $R_L = 4\Omega$	- - -	79 80 78	- - -	%
$\eta$	Total power efficiency, 115V <sub>AC</sub> / 60Hz	$P_o = 300\text{W}$ , $R_L = 4\Omega$ $P_o = 200\text{W}$ , $R_L = 4\Omega$ $P_o = 100\text{W}$ , $R_L = 4\Omega$	- - -	73 76 77	- - -	%

Table 13: Power specifications

## Audio Specifications

Measurements are done using an Audio Precision AES17 20 kHz 7<sup>th</sup> order measurement filter unless otherwise specified.

Symbol	Parameter	Conditions	Min	Typ	Max	Unit
$P_o$	Output power at 1%THD+N $f = 1\text{kHz}$	$R_L = 4\Omega$ 230V <sub>ac</sub> / 50Hz 115V <sub>ac</sub> / 60Hz 100V <sub>ac</sub> / 50Hz 85V <sub>ac</sub> / 50Hz	- - - -	310 310 310 290	- - - -	W

P <sub>o</sub>	Output power at 1%THD+N 20Hz < f < 20kHz	R <sub>L</sub> = 4Ω				
		230V <sub>ac</sub> / 50Hz	-	290	-	W
		115V <sub>ac</sub> / 60Hz	-	290	-	
		100V <sub>ac</sub> / 50Hz	-	260	-	
		85V <sub>ac</sub> / 50Hz	-	220	-	
P <sub>o</sub>	Output power at 0.1%THD+N 20Hz < f < 20kHz	R <sub>L</sub> = 4Ω				
		230V <sub>ac</sub> / 50Hz	-	260	-	W
		115V <sub>ac</sub> / 60Hz	-	260	-	
		100V <sub>ac</sub> / 50Hz	-	240	-	
		85V <sub>ac</sub> / 50Hz	-	210	-	
P <sub>o</sub>	Output power at 10%THD+N f = 1kHz	R <sub>L</sub> = 4Ω				
		230V <sub>ac</sub> / 50Hz,	-	380	-	W
		115V <sub>ac</sub> / 60Hz	-	380	-	
		100V <sub>ac</sub> / 50Hz	-	370	-	
		85V <sub>ac</sub> / 50Hz	-	330	-	
P <sub>o</sub>	Output power at 1%THD+N f = 1kHz	R <sub>L</sub> = 2.7Ω				
		230V <sub>ac</sub> / 50Hz	-	460	-	W
		115V <sub>ac</sub> / 60Hz	-	460	-	
		100V <sub>ac</sub> / 50Hz	-	405	-	
		85V <sub>ac</sub> / 50Hz	-	325	-	
P <sub>o</sub>	Output power at 1%THD+N 20Hz < f < 20kHz	R <sub>L</sub> = 2.7Ω				
		230V <sub>ac</sub> / 50Hz	-	325	-	W
		115V <sub>ac</sub> / 60Hz	-	335	-	
		100V <sub>ac</sub> / 50Hz	-	295	-	
		85V <sub>ac</sub> / 50Hz	-	255	-	

Table 14: Audio specifications

## Audio Specifications for 300ASC powering a 300AC amplifier as hanger module

Symbol	Parameter	Conditions	Typ		Unit
			300ASC	300AC	
P <sub>O</sub>	2 channel output power, at less than 0.03%THD+N, f = 1kHz 300ASC powering a 300AC from its DC-bus	300ASC, R <sub>L</sub> = 2.7Ω	350	100	W
		300AC, R <sub>L</sub> = 8 Ω			
		230V <sub>ac</sub> / 50Hz			
		115V <sub>ac</sub> / 60Hz			
	Output power/voltage drive, at less than 1%THD+N, f = 1kHz 300ASC powering a 300AC from its DC-bus	300ASC, R <sub>L</sub> = 2.7Ω	300W	34.6Vrms (150W)	
		300AC, R <sub>L</sub> = 8 Ω			
		230V <sub>ac</sub> / 50Hz			
		115V <sub>ac</sub> / 60Hz	300W	34.6Vrms (150W)	

Table 15: Audio specifications for 300ASC powering a 300AC

## General Audio Specifications

Unless otherwise specified, f=1kHz, P<sub>O</sub>=1W, T<sub>a</sub>=25 °C.

Measurements are done using an Audio Precision AES17 20 kHz 7<sup>th</sup> order measurement filter unless otherwise specified.

Symbol	Parameter	Conditions	Min	Typ	Max	Units
THD+N	THD+N in 4Ω	f = 100Hz, P <sub>O</sub> =1W	-	0.005	-	%
V <sub>N,0</sub>	Output referenced idle noise	A-weighted	-	75	-	μV
		Un-weighted, BW=20kHz	-	105	-	
A <sub>V</sub>	Nominal Voltage Gain	f = 1 kHz	28.0	28.15	28.3	dB
f	Frequency response	20Hz - 20kHz, Z <sub>L</sub> ≥ 4Ω	-	±0.5	±1.0	dB
f <sub>u</sub>	Upper bandwidth limit (-3dB)	R <sub>L</sub> = 8Ω	-	70	-	kHz
		R <sub>L</sub> = 4Ω	-	55	-	kHz
f <sub>l</sub>	Lower bandwidth limit (-3dB)	R <sub>L</sub> = All loads	-	2	-	Hz
R <sub>i</sub>	Input impedance, Signal IN+ and IN-		-	47	-	kΩ

R <sub>sense</sub>	Input impedance, Signal Sense +		-	200	-	k $\Omega$
	Input impedance, Signal Sense -		-	40	-	
Z <sub>o</sub>	Absolute output impedance	f = 100Hz	-	6	-	m $\Omega$
Z <sub>L</sub>	Load impedance range		2.5	4	$\infty$	$\Omega$
D	Dynamic range	A-weighted at 300W, 4 $\Omega$	-	113	-	dB
IMD	Intermodulation Distortion (CCIF)	f = 18kHz, 19kHz, P <sub>O</sub> = 10W	-	0.0015	-	%
TIM	Transient Intermodulation Distortion (TIM)	f <sub>1</sub> = 3.15kHz square, f <sub>2</sub> = 15kHz, P <sub>O</sub> = 10W	-	0.0045	-	%

Table 16: General audio specifications

## Electrical Specifications

Unless otherwise specified,  $T_a=25^{\circ}\text{C}$ .

Symbol	Parameter	Conditions	Min	Typ	Max	Units
$f_o$	Switching frequency, amplifier	Idle	-	480	-	kHz
$f_s$	Switching frequency range, amplifier	Idle to full scale variation	100	-	500	kHz
$f_{smps}$	Switching frequency, power supply		-	65	-	kHz
$V_{OFF,Diff}$	Differential offset on output terminals	Input terminated	-	$\pm 5$	$\pm 20$	mV
$V_{OFF,CM}$	Common mode offset on output terminals	Input terminated	-	27.25	-	V
$V_{trig\_ss}$	Signal Sense trigger level	80 – 500Hz	-	3	-	mV <sub>RMS</sub>
$V_{trig\_5V}$	5V trigger – trig level		1.8	-	-	V
$V_{off\_5V}$	5V trigger – off level		-	-	0.8	V
$V_{trig\_12V}$	12V trigger – trig level		3.8	-	-	V
$V_{off\_12V}$	12V trigger – off level		-	-	1.5	V
$I_{LED\_green}$	LED current - green		-	5	-	mA
$I_{LED\_red}$	LED current - red		-	2.5	-	mA

Table 17: Electrical specifications

## Timing Specifications

Unless otherwise specified,  $T_a=25^{\circ}\text{C}$ .

Symbol	Parameter	Conditions	Min	Typ	Max	Units
$t_{acd}$	Power supply start up delay.	Time from reaching $AC_{min}$ to all power supplies are good	-	450	-	ms
$t_{sd}$	Switching delay at start up	Time from all power supplies are good to amplifier startup	-	250	-	ms
$t_{standby}$	Shutdown delay	Time to shut down from signal on Signal Sense disappears	-	13	-	min

Table 18: Timing specifications

## Mechanical Specifications

During development, the ICEpower300ASC has sustained tough mechanical tests to ensure high reliability.

Test	Acceleration	Amount
Unpowered tests: The unit is powered after the test to verify functionality.		
Random vibration	2,1G rms, random profile composed of 5 frequencies in the range 5 Hz to 275 Hz	3 perpendicular directions 3 x 20 min. + 3 x 10 min. + 3 x 10 min.
Bump	10G, 16 ms pulse, half sinusoidal	1000 bumps in 6 directions 2-4 bumps per second
Shock	40G/26ms to 70G/12ms in steps of 10G	6 directions, 3 shocks per direction
Powered tests: The unit is tested with power applied.		
Sinusoidal vibrations	5 - 10 Hz/2,5 mm 10 - 100 Hz/1 g	3 directions, 2 hours per direction
Random vibrations	10 - 20 Hz 0,01g <sup>2</sup> /Hz 20 -150 Hz, - 3 dB/oct. 0,7 g RMS	3 directions, 2 hours per direction

Table 19: Mechanical tests

*6 directions: (up, down, left, right, forward and backward). 3 directions: (up and down, left and right, forward and backward)*

## Other Environmental Testing

ICEpower300ASC is tested for surge and transients on AC mains as well as surge voltages caused by lightning to ensure the module performance.

Extensive environmental testing is performed to ensure the module robustness. These tests include Highly Accelerated Life Test (HALT), thermal shock and cycling, moisture and mechanical shock and vibration.



## Typical Performance Characteristics

### Frequency Response

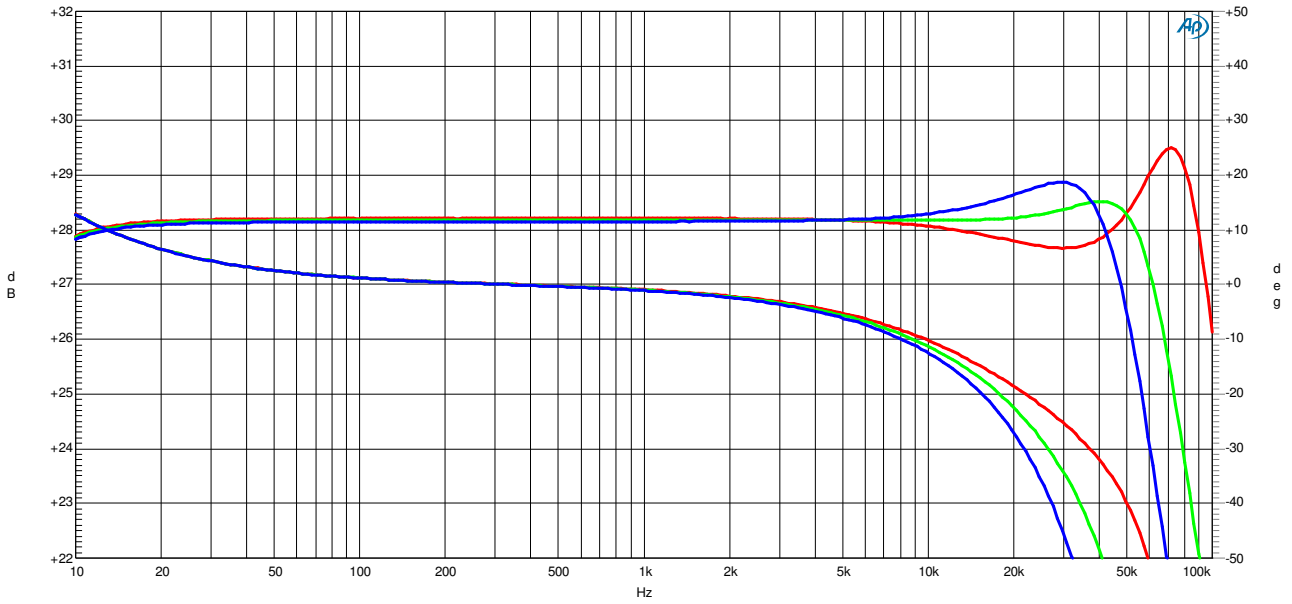

Figure 3: Frequency response in 4Ω (blue), 8Ω (green) and open load (red). Top – amplitude. Bottom – phase

### Harmonic Distortion and Noise

All measurements are done with an Audio Precision AES17 20 kHz 7<sup>th</sup> order measurement filter.

#### THD+N vs. Power

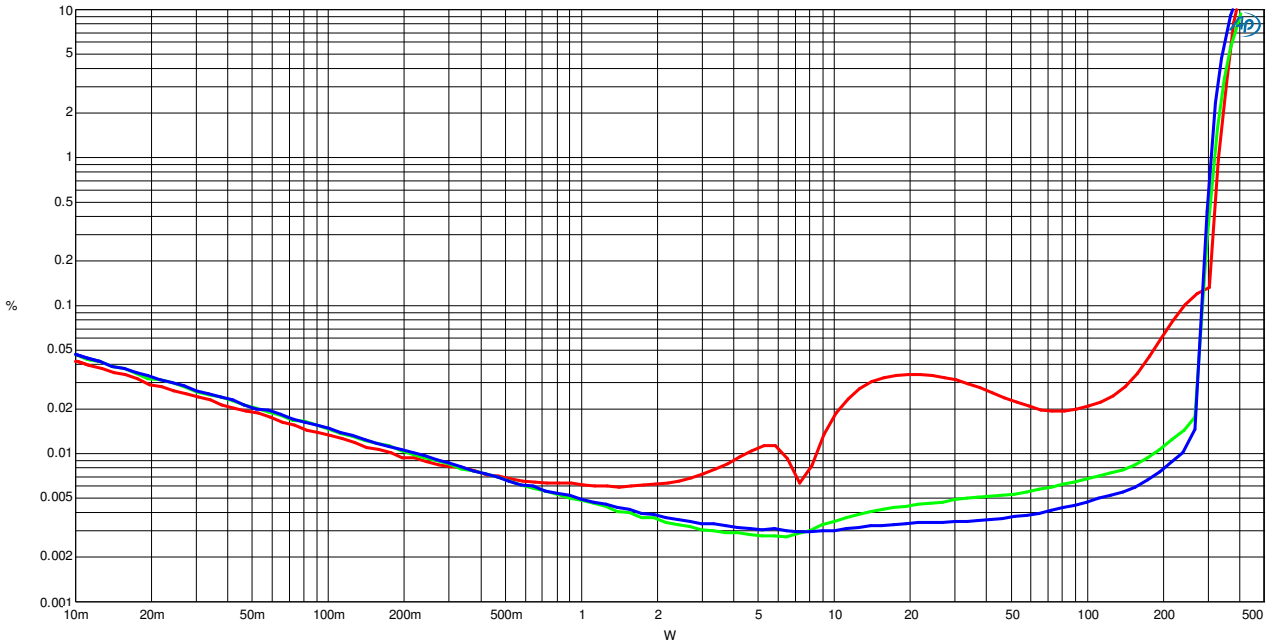

Figure 4: THD+N vs. Po at 100Hz (blue), 1kHz (green) and 6.67kHz (red), 4Ω, 230Vac/50Hz

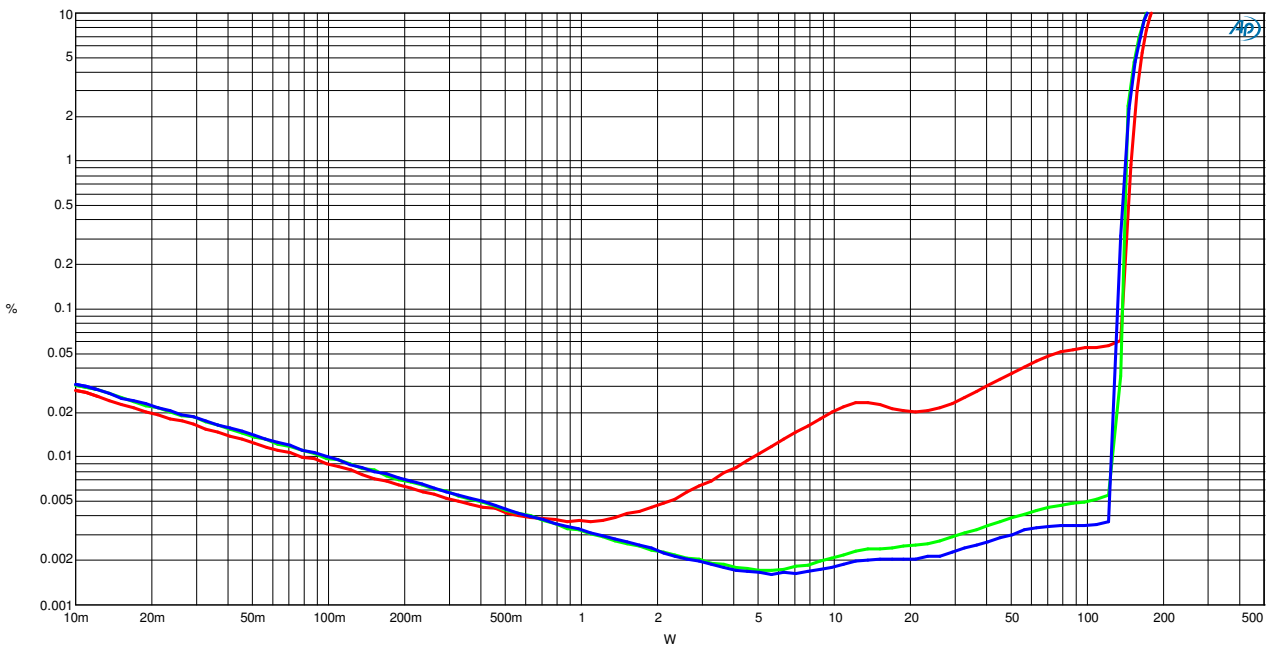

Figure 5: THD+N vs. Po at 100Hz (blue), 1kHz (green) and 6.67kHz (red), 8Ω, 230Vac/50Hz

### Spectral View (FFT)

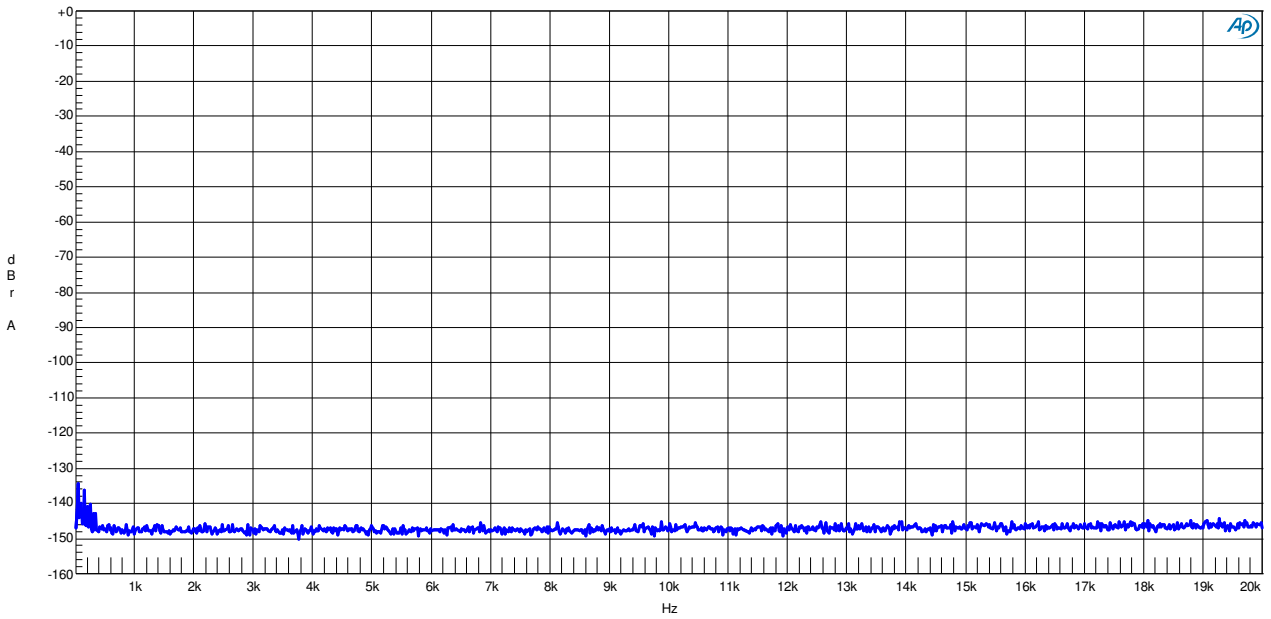

Figure 6: Idle noise (16K FFT). Residual = 75 $\mu$ V(A)

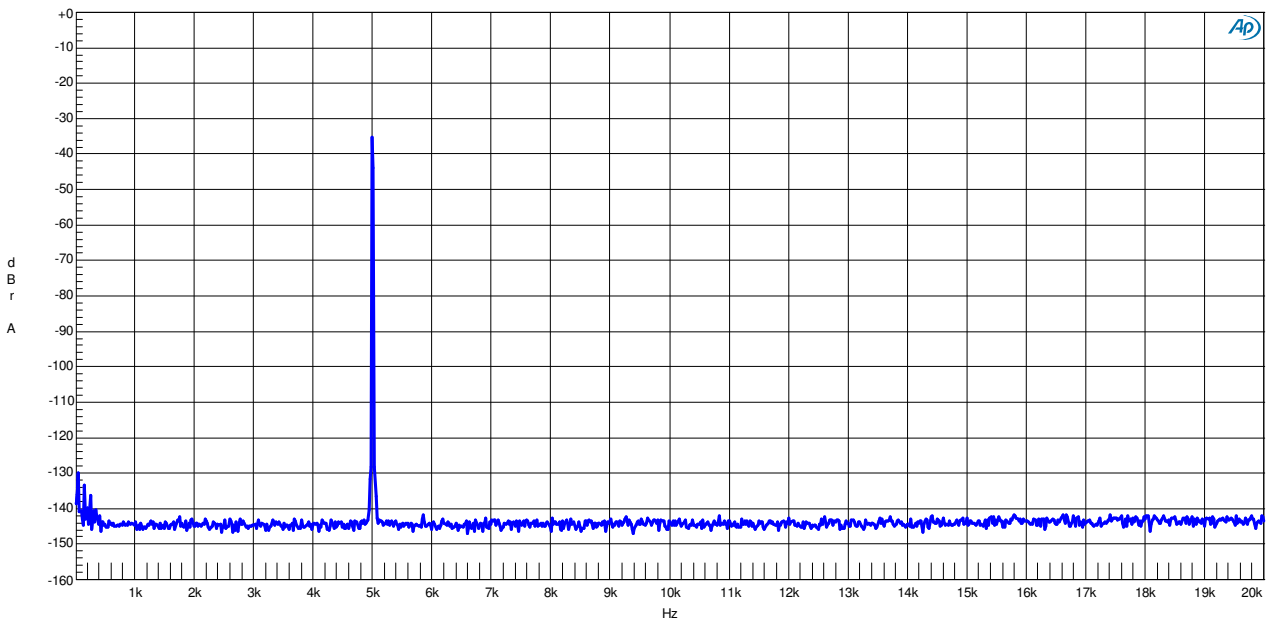

Figure 7:  $f = 5\text{kHz}$ ,  $P_o = 100\text{mW}$ ,  $4\Omega$

### Intermodulation Distortion (CCIF & TIM)

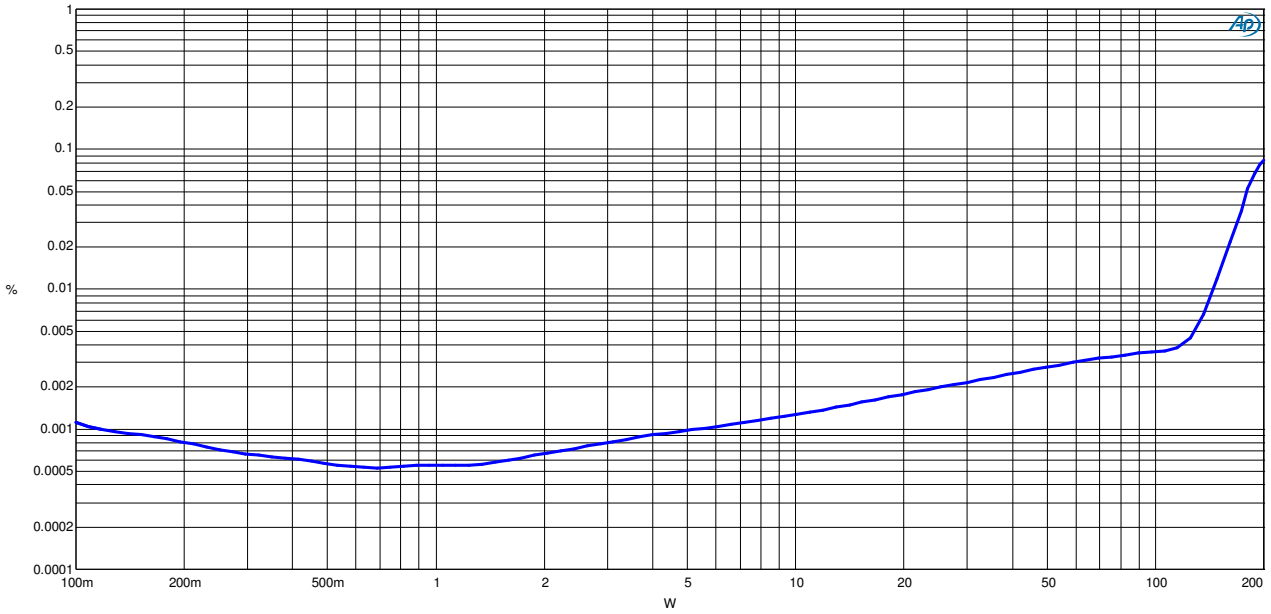

Figure 8: CCIF IMD vs. Output Power,  $R_L = 4\Omega$ ,  $f_1 = 18\text{kHz}$ ,  $f_2 = 19\text{kHz}$ , 1kHz

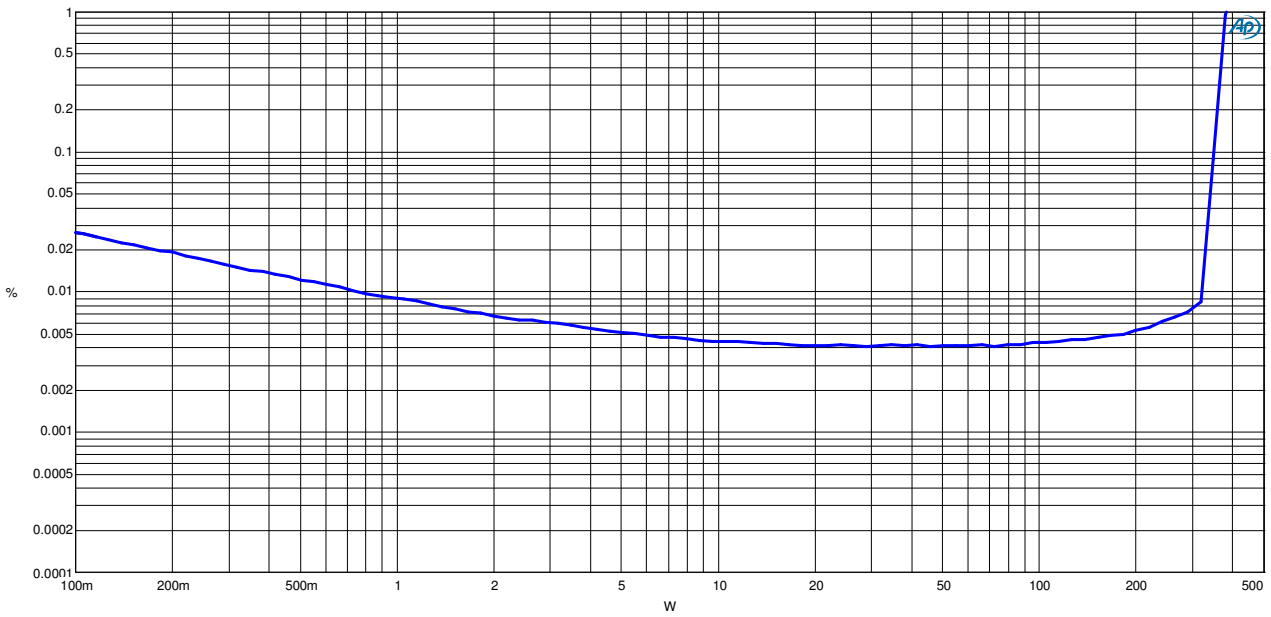

Figure 9: TIM vs. output power.  $R_L = 4\Omega$

## Output Impedance

The output impedance is measured using a delta load method where the difference in output amplitude at two different resistive loads is used to calculate the equivalent output impedance of the amplifier. The output impedance is measured directly at the terminals on the PCB.

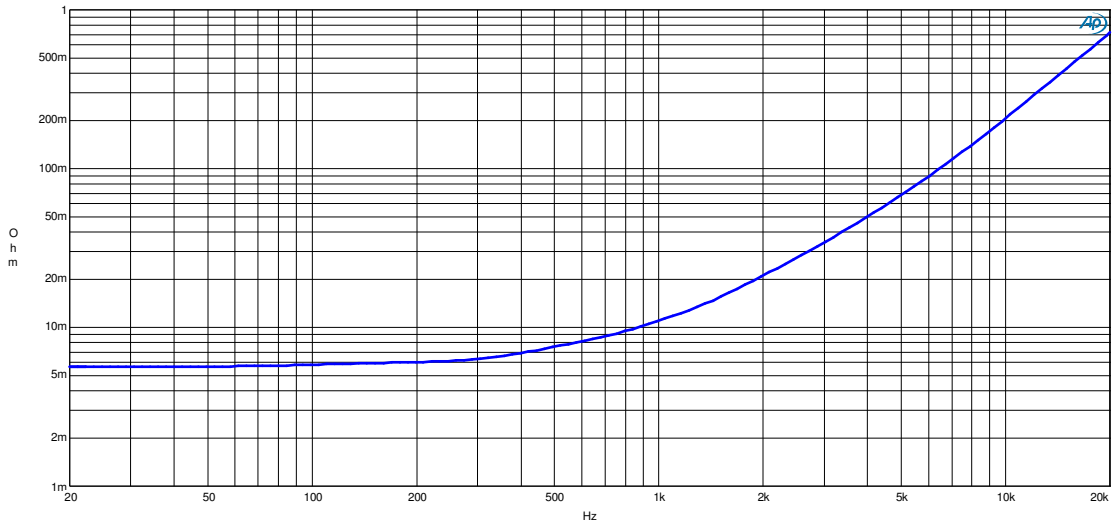

Figure 10: Output impedance at the output terminals

## Damping Factor

The damping factor is calculated as the ratio between the output impedance of the amplifier and the load impedance.

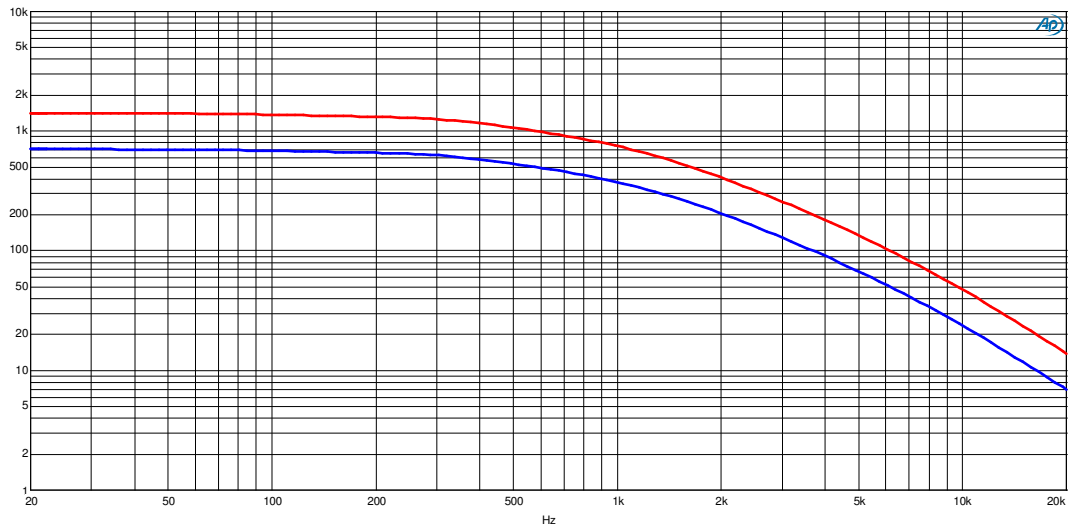

Figure 11: Damping factor vs. frequency 4Ω (blue) and 8Ω (red)

With its low output impedance, the ICEpower300ASC is designed to be unaffected by loudspeaker loading characteristics. However, care should be taken with purely capacitive loads.

The maximum purely capacitive load allowed is 220nF.

### Power Efficiency

The total power efficiency from AC mains to amplifier output is given below.

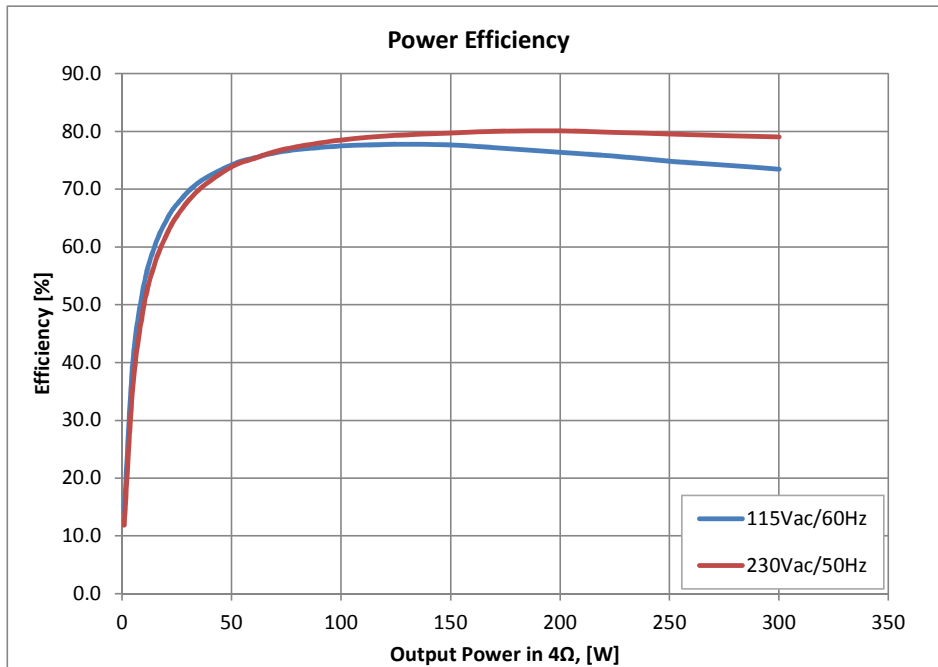

Figure 12: Efficiency vs. output power

### Dissipated Power

The total dissipated power within the module from AC mains to amplifier output is given below.

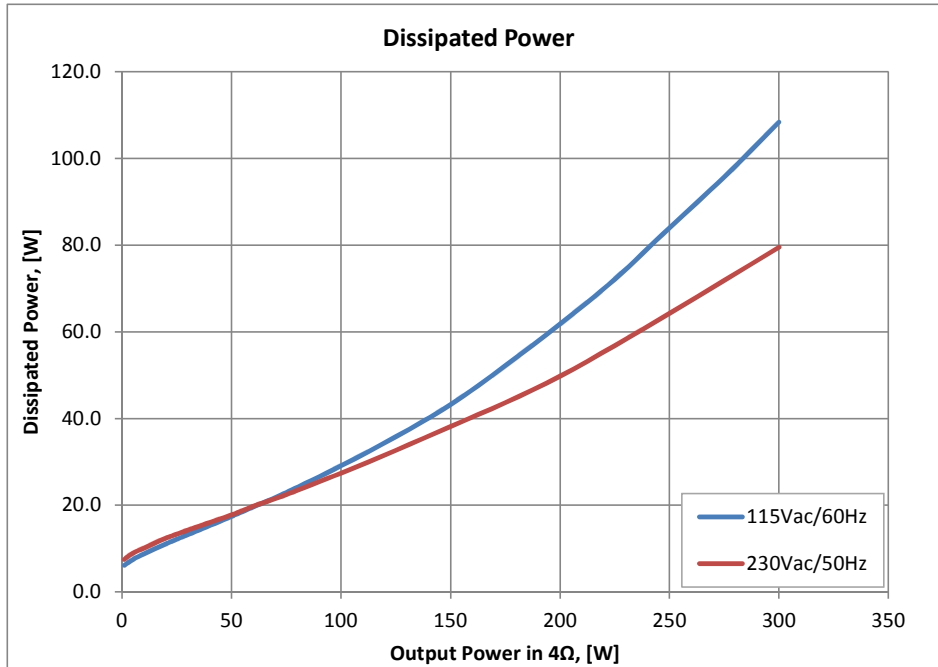

Figure 13: Dissipated power vs. output power

## Input/Output Schematics and Features

### Input Stage

The balanced input section provides signal buffering and anti-aliasing filtering. The balanced configuration helps to avoid hum and noise pick-up from poorly shielded cables. An unbalanced input can be obtained by applying a short circuit between Signal In- and Signal GND. This does not affect the overall gain.

The input impedance is  $R_i=47\text{kohm}$  at low frequencies and  $|Z_i|>25\text{k}\Omega$  over the full audio band.

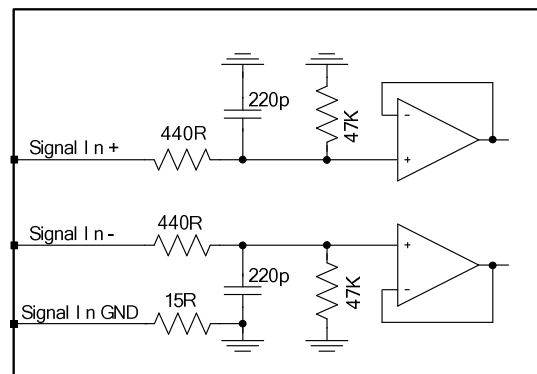

Figure 14: Balanced input buffer

### Output Stage

The output stage is a full bridge topology with a 2<sup>nd</sup> order filter, thus the power output on the terminals Vo+ and Vo- is balanced. The filter design is a part of the proprietary HCOM topology and has been chosen as a compromise between demodulation characteristics, efficiency and filter compactness.

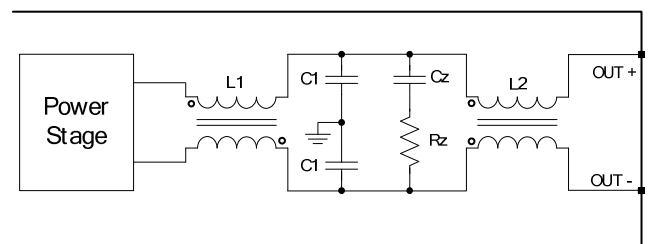

Figure 15: Output filter section with compensating Zobel network

**Warning:** The balanced speaker outputs are both "hot" with a common-mode DC level equal to  $V_D/2$  (27.25V). Shorting one of the terminals to ground will cause high stress to the module and should be avoided. Balanced probes should always be used for monitoring and measurements.



VD (+54.5V)

This high power DC output is intended for powering stand-alone amplifier modules like the ICEpower 300AC. Maximum output power including the onboard 300ASC amplifier output power is 300W.

Warning: The output is not short circuit protected. Continuous overload may permanently damage the power supply.

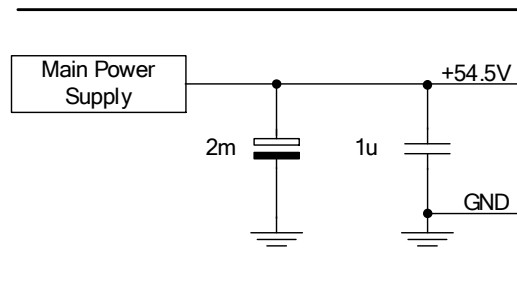

Figure 16: VD (+54.5V) output

Signal Sense and Triggers (5V and 12V)

The ICEpower300ASC has two trigger inputs and a signal sense input that turns on the power supply and amplifier. The two trigger inputs and the signal sense perform a logic OR function internally. The 5V trigger has an internal weak pull-up to ensure that the amplifier as default will power up if the trigger inputs are left open.

The board is able to power up from standby mode by applying an audio signal to the Balanced Signal Sense input. Single ended Signal Sense can be used via connector P3 pin 4 or P4 pin 1 but requires the negative signal sense input to be shorted to Signal Sense GND.

When an audio signal is detected, the power supply will switch from standby mode to on mode and the amplifier will turn on. The power supply will return to standby mode again if no audio signal has been detected for 13 minutes.

If this feature is not required, the input can be left unconnected or connected to ground.

The input impedance of the signal sense input is  $R_{sense} > 200k\Omega$  for the positive input and  $R_{sense} > 40k\Omega$  for the negative input at low frequencies. Over the entire audio band width, the signal sense input impedance is  $|Z_{sense}| > 30k\Omega$  for either input. The internal circuit is shown in Figure 17.

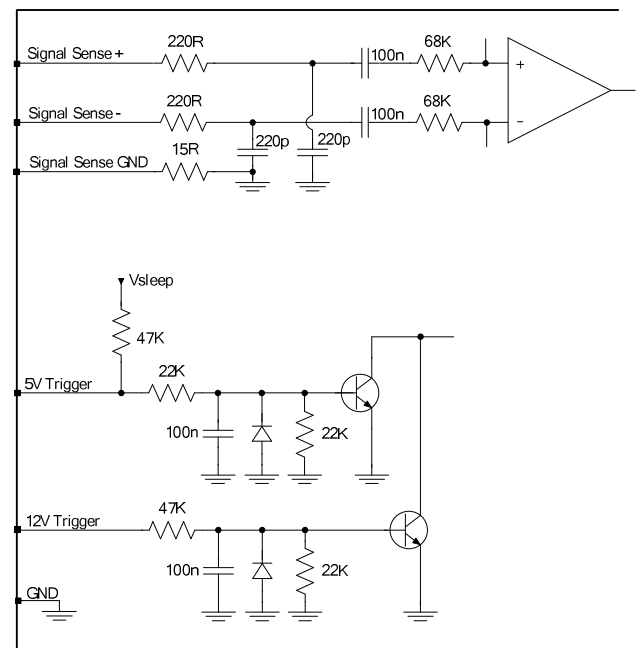

Figure 17: Signal Sense and Trigger inputs

Typical usage of Signal Sense and Triggers:

1. Always on:



Leave signal sense and trigger inputs open. In this mode, the amplifier will never enter standby.

2. Automatically standby and power on depending on the audio input:  
Connect the signal sense input to the audio signal and pull the 5V trigger low. The amplifier will power on when audio is present and enter standby after 13 minutes without audio.
3. Manual standby and power on via 5V trigger:  
Leave signal sense unconnected and drive the 5V trigger low to enter standby and high to power on.
4. Manual standby and power on via 12V trigger:  
Leave signal sense unconnected and short the 5V trigger to GND. Drive the 12V trigger low to enter standby and high to power on.

To improve the noise immunity for an unused signal sense input, short Signal Sense +, Signal Sense - and Signal Sense GND.

Signal sense and triggers can be used together, too. When a trigger input is driven from high to low, the amplifier will enter standby immediately. However, if a signal is present on the signal sense, the amplifier will power on again. To force standby when using signal sense, the audio signal must be turned off before the triggers are driven low.

### Standby/On LED indication

Figure 18 shows how to connect the external LEDs for indicating On/Standby modes. The figure also shows the internal circuit that drives the two LED's. If LED indication is not required, any of the two LED's can be left out without affecting operation of the board. Red light indicates Standby mode/Protection Mode and green light indicates On mode.

The red LED will turn on if any of the amplifier protection features are activated. The red light will also illuminate during the power up sequence, and not switch off until the amplifier is enabled and ready to play. The green LED will remain turned on during protection indication.

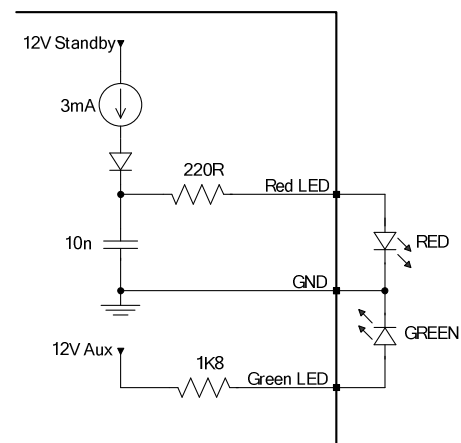

Figure 18: LED indication for St-by/ON

### +5V and $\pm 12V$ Auxiliary

The +5V output can be used to power digital signal processor and other auxiliary low voltage circuits. The  $\pm 12V$  outputs can likewise be used to power analog audio circuits.

The +5V output can supply up to 1A while the +12V can supply 300mA and the -12V can supply 200mA. The available power from the three outputs combined is 8W.

All three auxiliary outputs are short circuit protected.

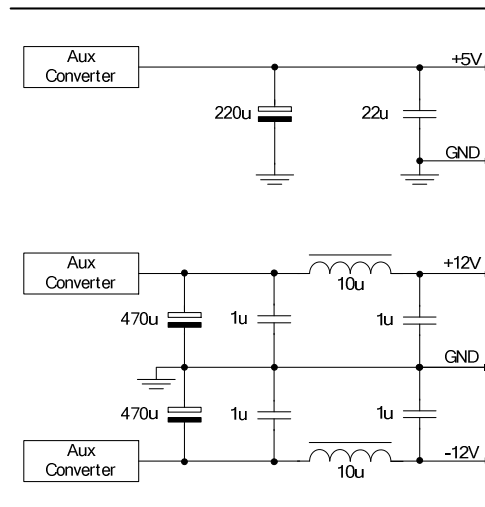

Figure 19: +5V and ±12V Auxiliary

Vsleep (+5V)

This low power DC output can be used for supplying external wake-up circuits such as microprocessors. The output can supply up to 10mA.

Vsleep is current limited and short circuit protected.

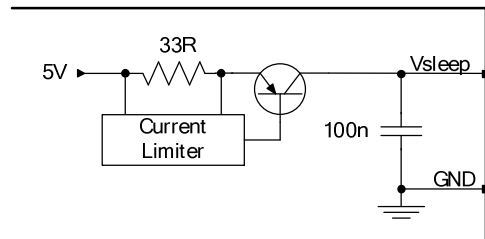

Figure 20: Vsleep output

### Operational Timing Diagram

The following diagrams show selected signals during power up/power down.

Timing with AC mains:

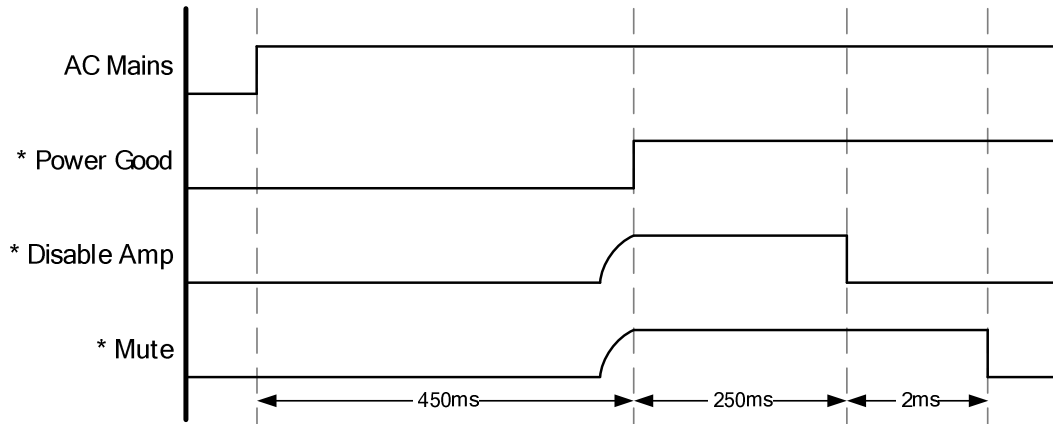

Figure 21: Power up from mains on. \* denotes an internal signal

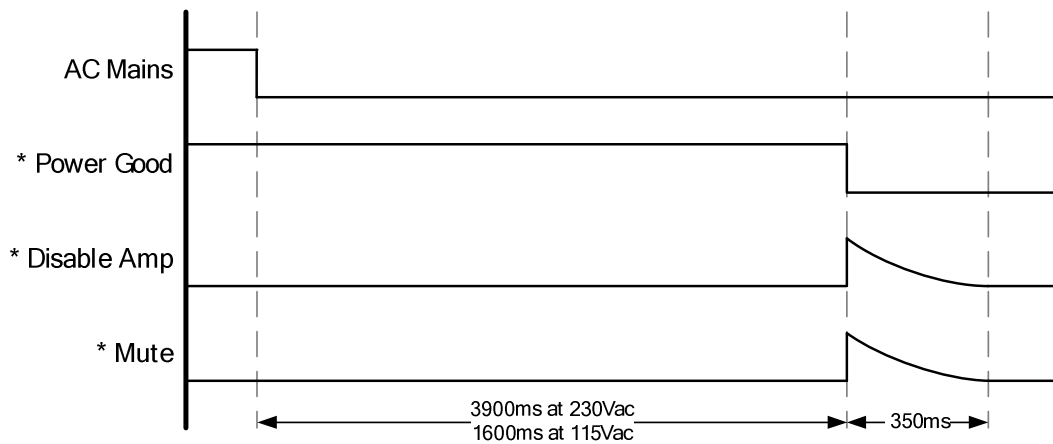

Figure 22: Power down after mains off without audio signal. \* denotes an internal signal

### Timing with Trigger Input

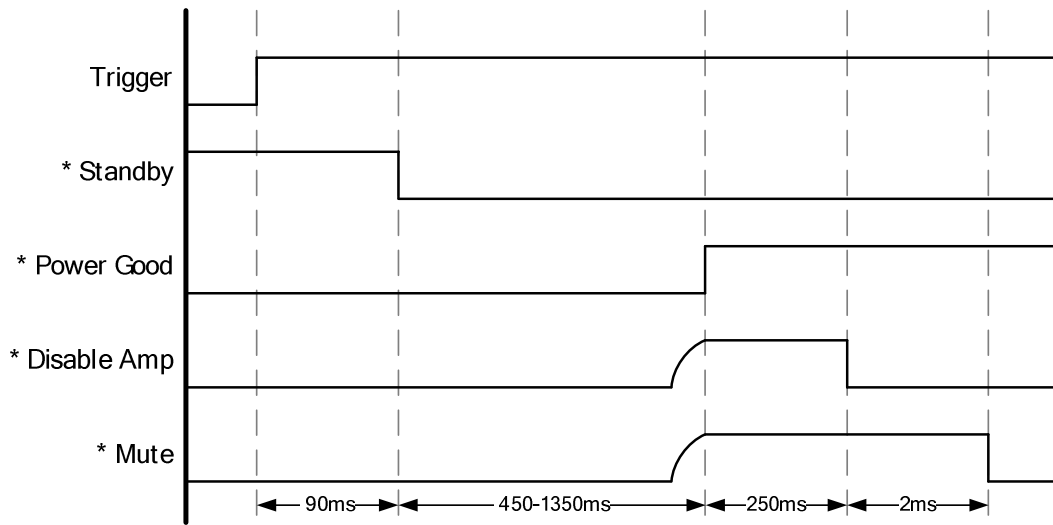

Figure 23: Power up from trigger high. \* denotes an internal signal

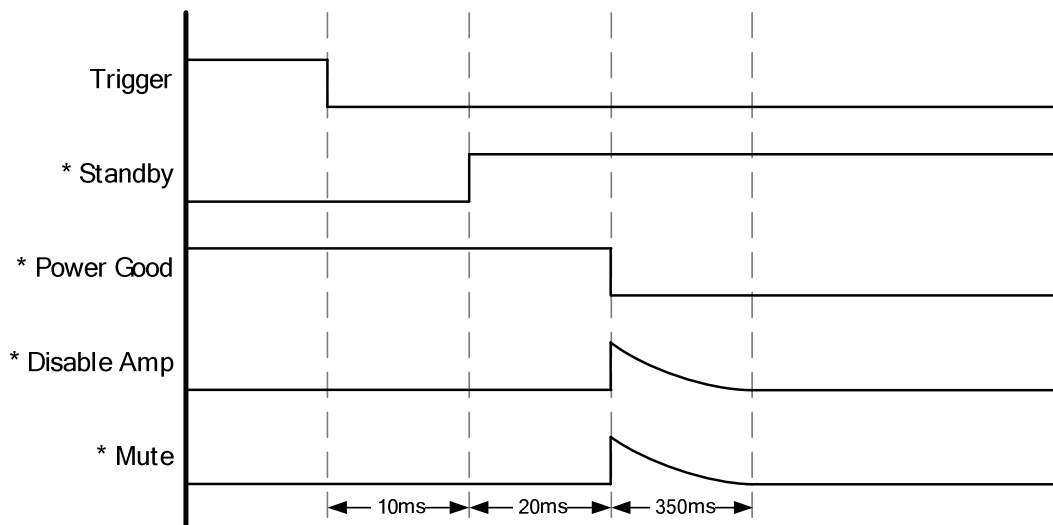

Figure 24: Power down after trigger low. \* denotes an internal signal

### Timing with Signal Sense

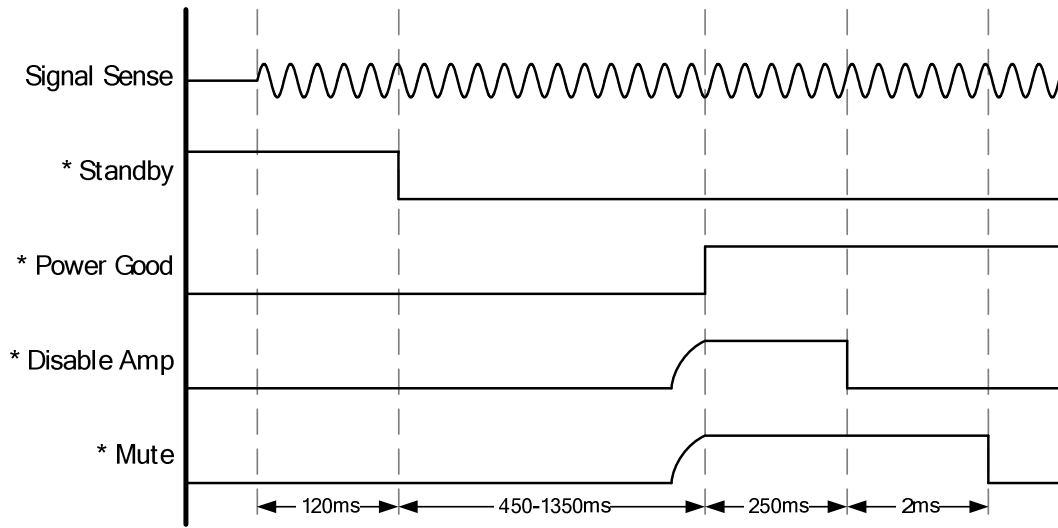

Figure 25: Power up on Signal Sense. \* denotes an internal signal

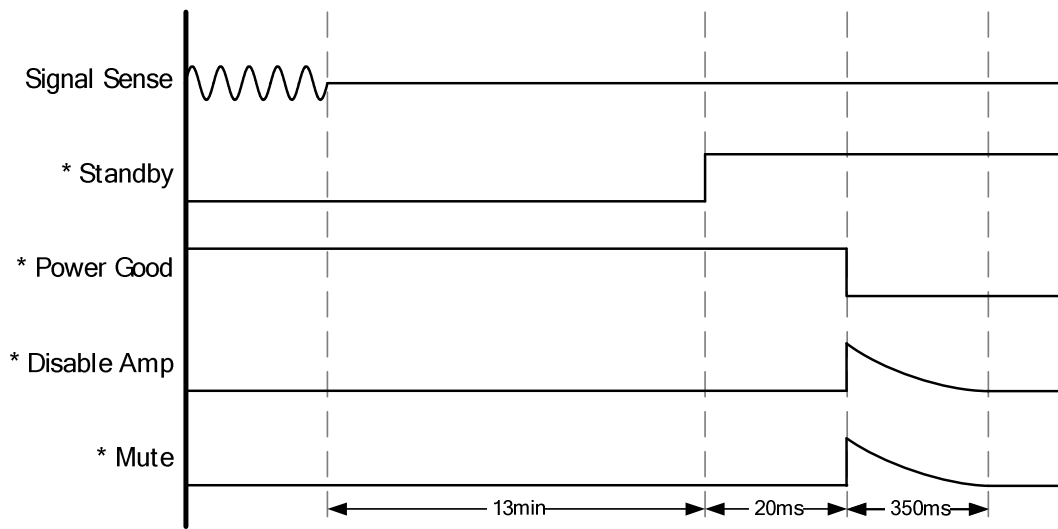

Figure 26: Power down controlled by Signal Sense. \* denotes an internal signal

## Protection Features

The ICEpower300ASC is equipped with several protection features for surviving overload without damage.

The schematic below illustrates the different protection features.

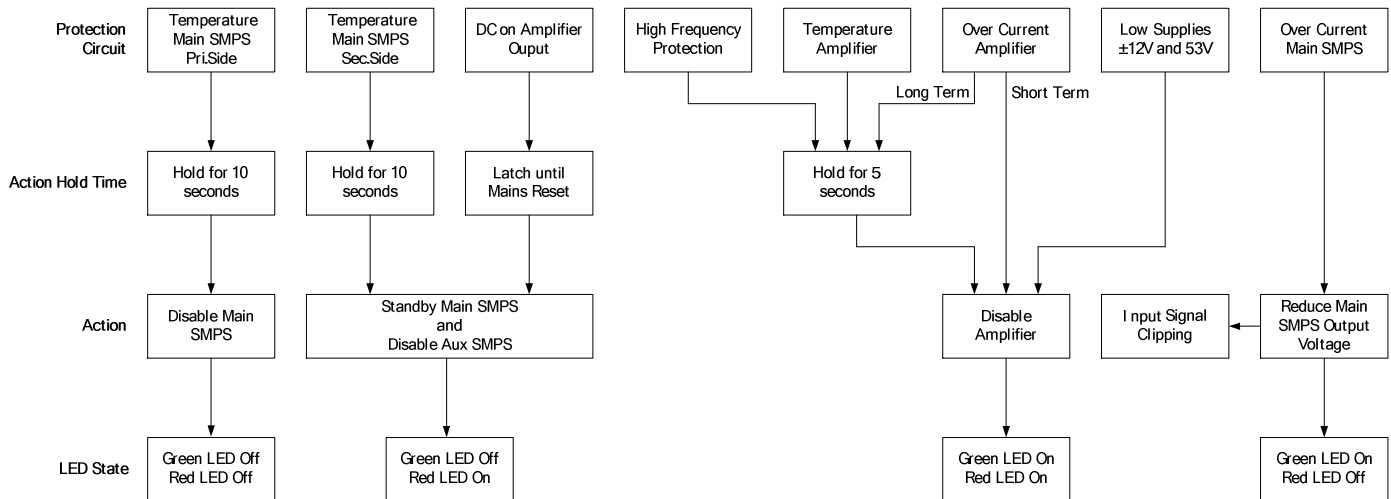

Figure 27: Block diagram of protection features.  
Normal LED state is Green On and Red Off.

### Overcurrent Protection (main SMPS)

If the momentary output current of the main power supply exceeds 12A or the average output power exceeds 350W for a period of time, the output voltage will be reduced causing the audio signal to clip in an attempt to limit the power. The main power supply is not designed to handle more than 300W continuous output power.

### Thermal Protection (power supply and amplifier)

The ICEpower300ASC is equipped with three thermal protection circuits. The first circuit monitors the temperature of the power supply primary side and disables it if the temperature becomes too high. The second monitors the power supply secondary side and puts the main power supply in standby if the temperature becomes too high. The third monitors the amplifier temperature and disables the amplifier if the temperature of the output stage becomes too high.

In all cases, the ICEpower300ASC amplifier will be disabled for a period of time (5 - 10 seconds) and then restart. Thermal shut down is only expected to occur in case of abuse or under fault conditions.

### DC on Amplifier Output

The audio input itself is AC coupled and to further reduce DC offset on the amplifier output a DC servo acts to keep the DC voltage below ±10mV. However, if a differential DC voltage of more than 3V is present on the amplifier output the power supply will be put in standby. The power supply is kept in standby until AC mains is removed and the VD voltage is fully discharged.

### High-frequency Protection (amplifier)

The amplifier has full power bandwidth from 20Hz to 20kHz. However, the output filter of the amplifier is not designed for long-term high frequency signals (>20kHz) with full amplitude. This is due to the power capabilities of the output Zobel-network. In such cases, the high-frequency protection circuit disables the amplifier for 5 seconds and then restarts.

### Overcurrent Protection (amplifier)

This feature protects the amplifier in case the output current exceeds 20A. When the current reaches 20A, the amplifier power stage will be briefly disabled and then continue normal operation. This means that the amplifier will perform automatic current clipping.

If the output is shorted or is in continuous over current, the amplifier will shut down for 5 second before continuing operation.

### Low Supplies ( $\pm 12V$ and $+54.5V$ )

Under voltage lockout is implemented to ensure that all supply voltages for the amplifier are within an acceptable range before the amplifier is enabled. If one of the low voltage supplies are below  $\pm 10V$  or the  $+54.5V$  supply drops below  $+30V$ , the amplifier is disabled.

### Thermal Design

The ICEpower300ASC is a self-cooled module thus eliminating the need for special attention to thermal design.

If the average output power at  $25^{\circ}C$  ambient temperature exceeds 100W (typical) into  $4\Omega$  for a long period of time, the module will reach its maximum allowable temperature and the temperature protection will be activated. At  $50^{\circ}C$  ambient temperature, more than 60W average power (typical) into  $4\Omega$  will activate the temperature protection.

To get optimal airflow and cooling of the module, vertical mounting is recommended.



### Physical Dimensions

All dimensions are in mm.

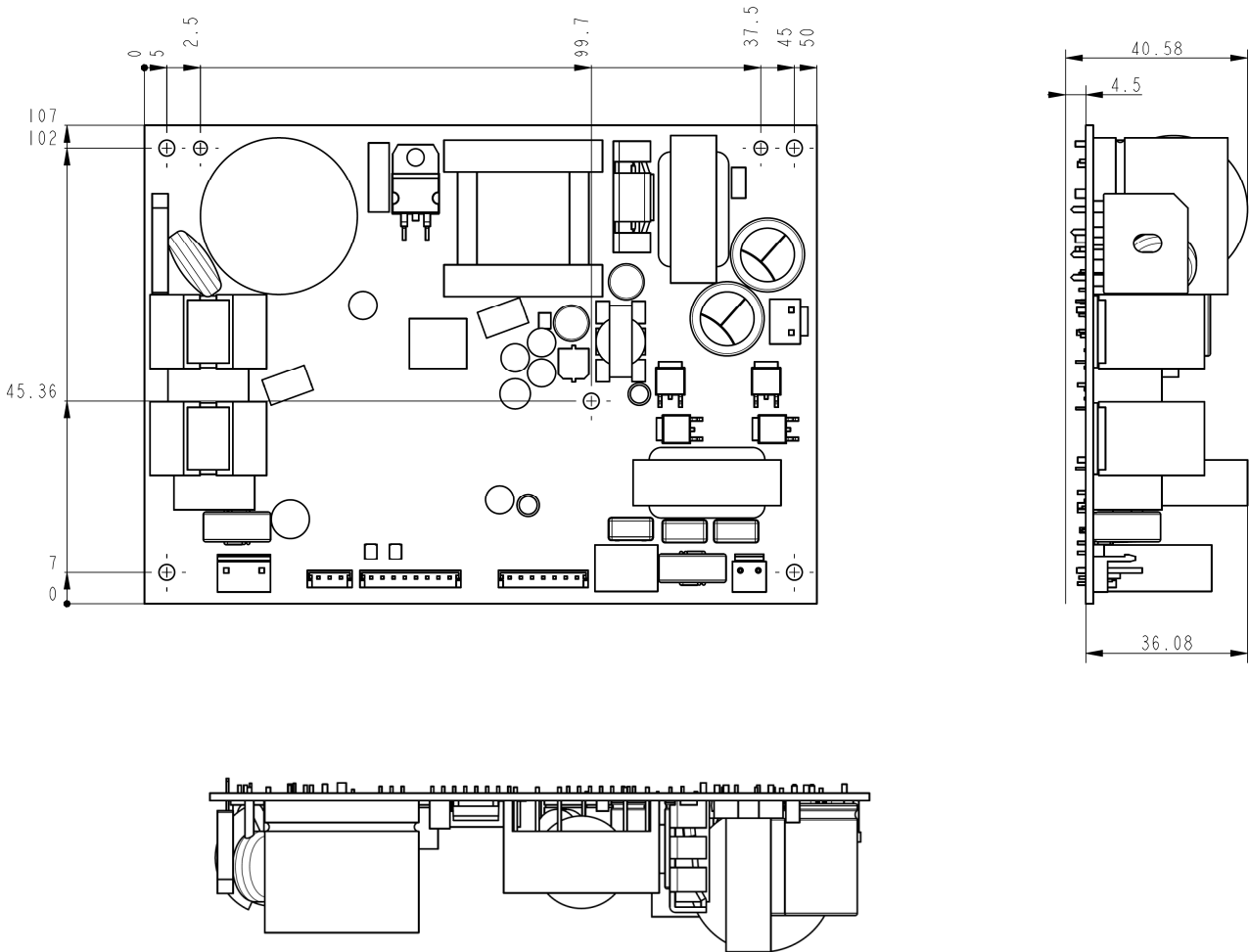

Figure 28: Physical dimensions in mm

Note: Always ensure sufficient clearance for AC mains and to ensure adequate ventilation

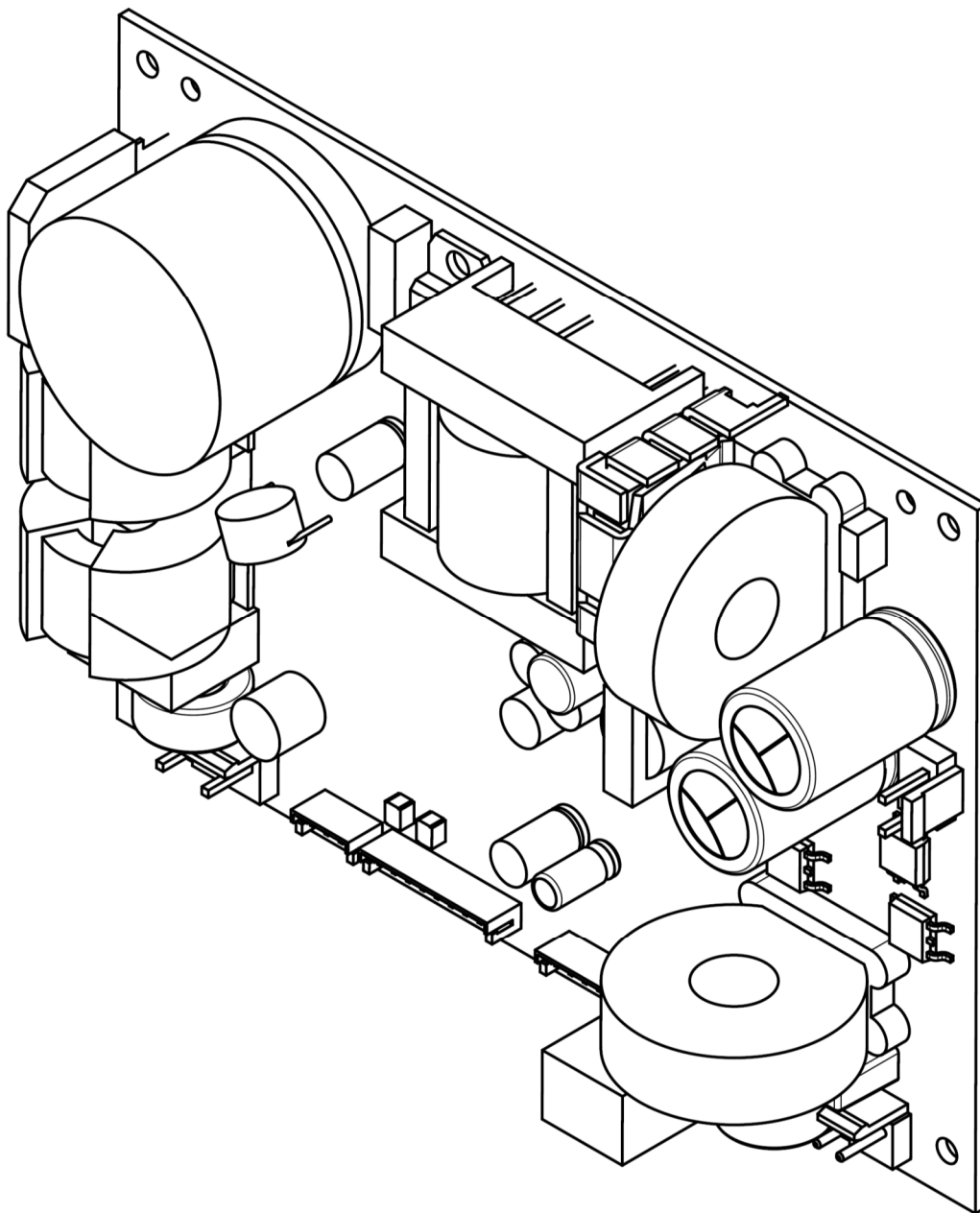

Figure 29: 3D view of the board

## Safety Standards

The ICEpower300ASC has been pre-approved for safety by UL to ease the design-in procedure and complies with the following standards:

Europe: IEC60065 7<sup>th</sup> ed.

US: UL60065 7<sup>th</sup> ed.

CA: CSA-C22.2 No. 60065-3

Safety class: Class 2 (without earth)

## EMI Standards

EMI Conforms to:

EN55013

EN55020

EN61000-3-2

EN61000-3-3

CISPR 13

CISPR 20

IEC 61000-3-2

IEC 61000-3-3

FCC part 15-B

## ESD Warning

ICEpower products are manufactured according to the following ESD precautions:

- IEC 61340-5-1: Protection of electronic devices from electrostatic phenomena. General Requirements.
- IEC 61340-5-2: Protection of electronic devices from electrostatic phenomena. User Guide.
- ANSI/ESD-S20.20-1999: Protection of Electrical and Electronic Parts, Assemblies and Equipment.

Further handling of the products should comply with the same standards.

The general warranty policy of ICEpower a/s does not cover ESD damaged products due to improper handling.

## Packaging and Storing

Package	Dimensions (w x d x h)	Gross Weight
Carton (33 modules)	59 x 39 x 20 cm	12 kg
Pallet (20 cartons)	120 x 80 x 115 cm	260 kg

Table 20: Package dimensions and weight

ESD safe cardboard is used for wrapping.

Storage humidity

Do not expose the pallets to rain or humidity levels higher than 85%.

Storage temperature

The pallets are to be stored at temperatures from 0°C to 70°C.

Stacking

Pallets may not be stacked on top of each other.

## Further Information

For additional information about the ICEpower® technology from ICEpower a/s, visit our web site or contact us.

ICEpower a/s

Gl. Lundtoftevej 1b

DK-2800 Kgs. Lyngby

Denmark

Phone +45 96841122

Fax +45 96845799

Website: <http://www.ICEpower.dk>

E-mail: [info@ICEpower.dk](mailto:info@ICEpower.dk)

## Notice

The data sheet contains specifications that may be subject to change without prior notice. ICEpower® is a trademark of ICEpower a/s. Photographs in the data sheet are for illustrative purposes only and cannot be used in a technical regard.

ICEpower a/s products are not authorized for use as critical components in life support devices or life support systems without the express written approval of the president and general counsel of ICEpower a/s. As used herein:

1. Life support devices or systems are devices or systems which (a) are intended for surgical implant into the body or (b) support or sustain life, and whose failure to perform when properly used in accordance with instructions for use provided in the labeling, can be reasonably expected to result in a significant injury to the user.
2. A critical component is any component of a life support device or system whose failure to perform can be reasonably expected to cause the failure of the life support device or system, or to affect its safety or effectiveness.