

KLARK TEKNIK GROUP

TECHNICAL BULLETIN

Walter Nash Road, Kidderminster, Worcestershire. DY11 7HJ. England

Tel: (44) (0) 1562 741515. Fax: (44) (0) 1562 745371

KLARK TEKNIK

MIDAS

SIGNAL PROCESSING BY DEFINITION BETTER BY DESIGN DESIGNED FOR A PURE PERFORMANCE

Brand	Reference Number	Date	<input type="checkbox"/> Urgent
Midas	126	17/04/2003	<input type="checkbox"/> Recommended
Product	Serial Number	Assembly	<input checked="" type="checkbox"/> Information Only
Legend 3000	Applied from 3361 onwards	Output Meters LC311C and LC321C	

Subject

Frequency response of output meters is low at 20kHz.

Information

It has been observed while carrying out frequency sweeps of Legend outputs that the response of the output meters is not flat and will drop off as the frequency increases above 10kHz.

This is a feature of the output meter circuitry and does not affect the audio path in any way. To improve the output meters response at higher frequencies the following resistors need to be changed from a 30k 1% 0603 package Metal film resistor to a 10k 1% 0603 package Metal film resistor. (Klark Teknik Part Number RES56-4E1R00)

Aux Meter PCB LC311

Resistors: R102, R202, R302, R402, R502, R602, R702, R802, R902, R1002, R1102 and R1202.

Group/ST Aux Return/Matrix Meter PCB LC321

Resistors: R102, R202, R302, R402, R502, R602, R702, R802, R902, R1002, R1102 and R1202.

As all of the meters are identical circuitry only one page of the schematics has been shown with the resistors highlighted. The board overlay is also included with the resistor positions highlighted.

Other Information

Distributed

All Distributors

Date Distributed

09/06/2003

Legend Output Module Overview

The Output module assembly part number is ALC311-5 (If you order complete tested output modules it is part number L311). The individual sub assembly part numbers are displayed below.

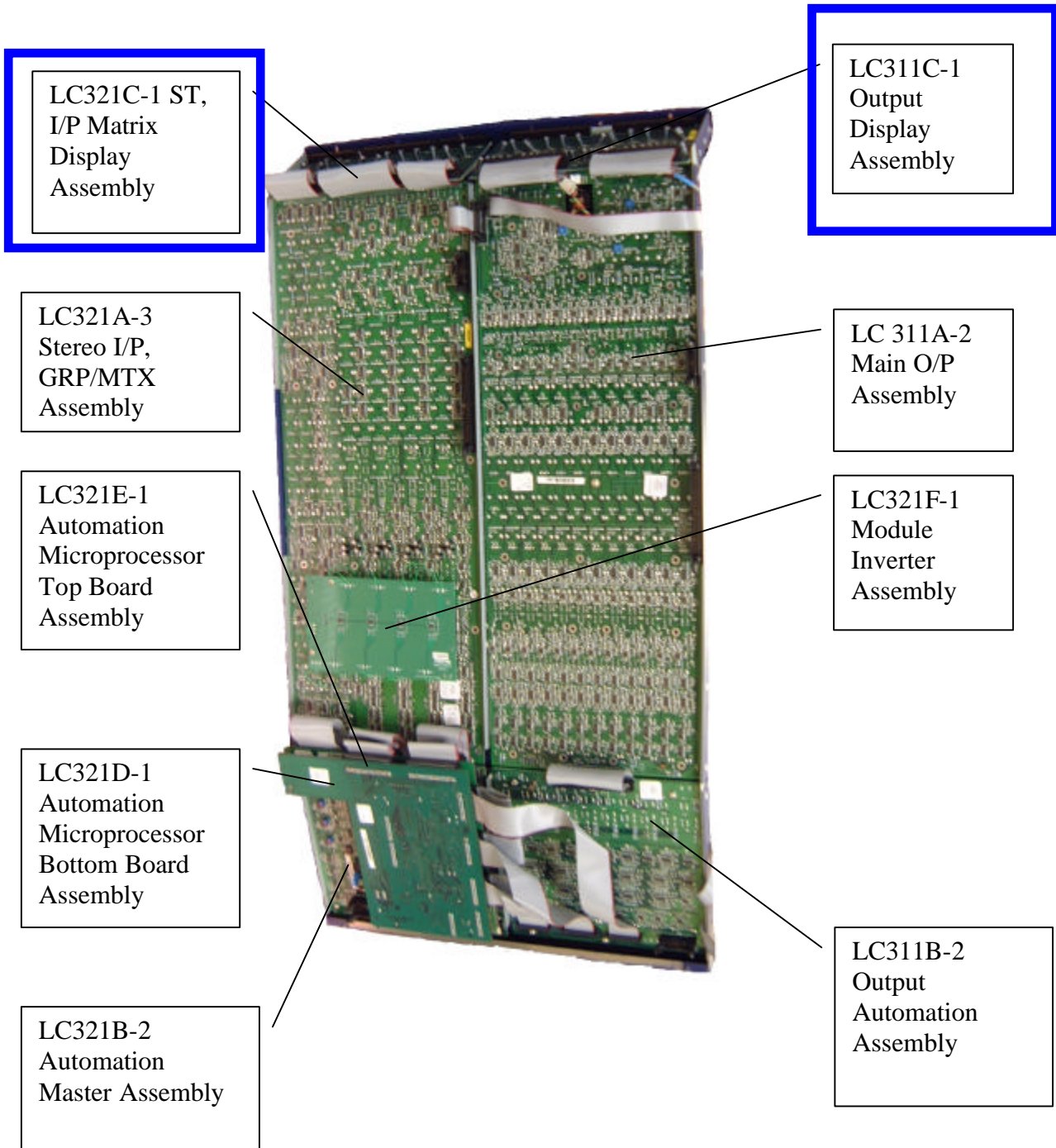

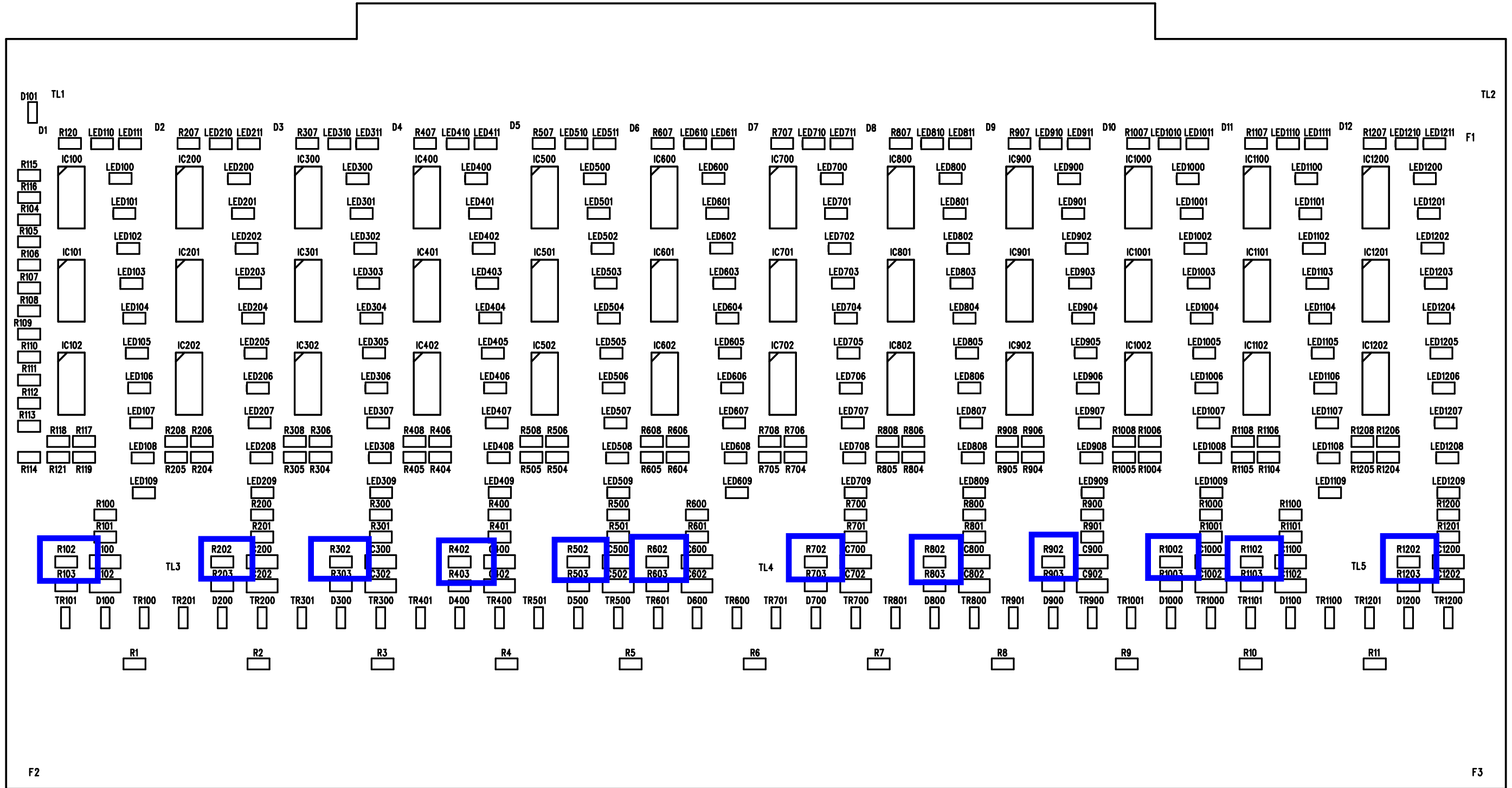

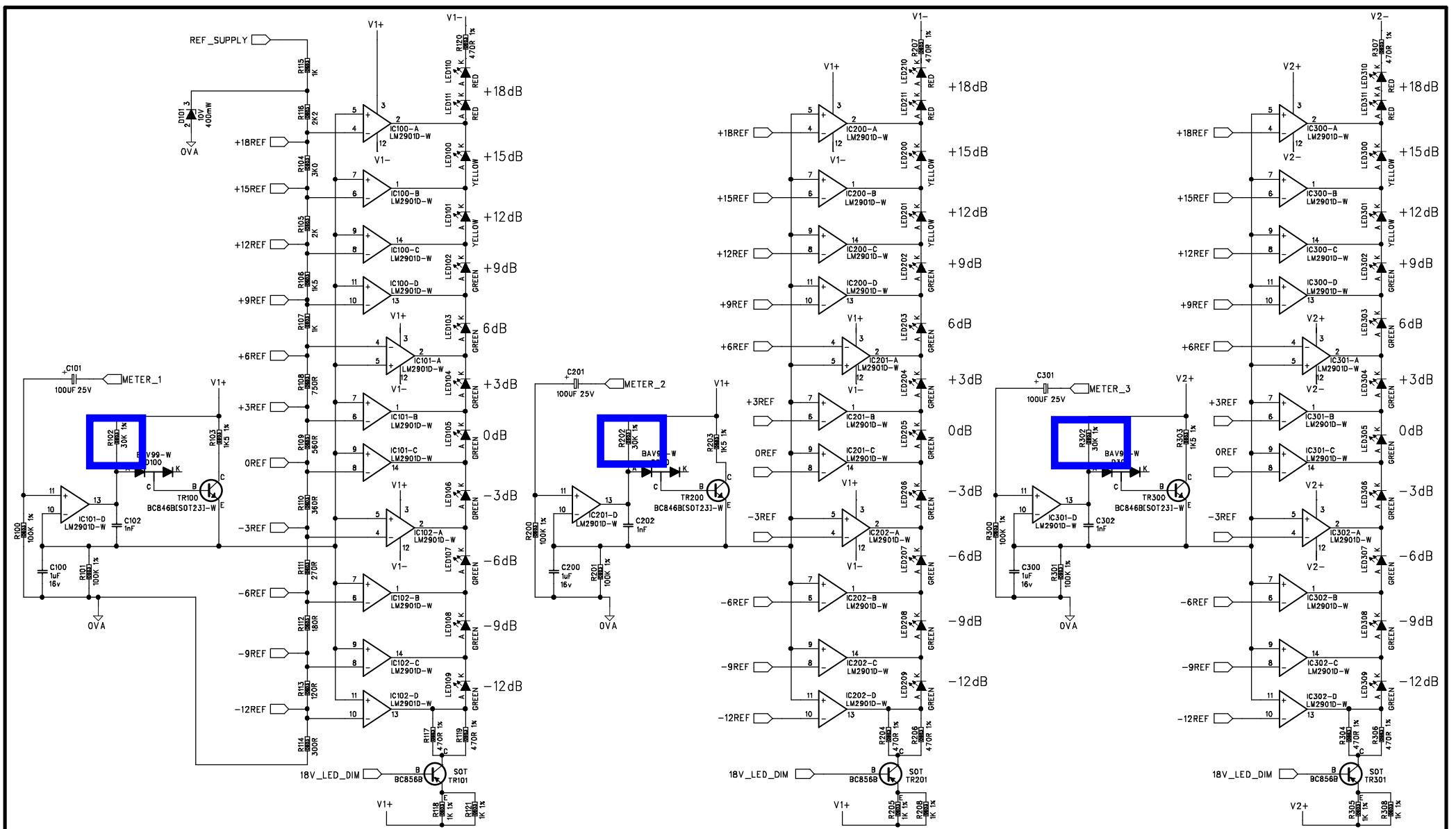

AMENDMENTS	ISS.	INIT.	DATE.

UNIT: LEGEND 3000
 TITLE: MASTER METERS 1-3
 BOARD No. LC321C BOARD Iss. 1

MIDAS AUDIO

DRAWN: MF/SM DATE: 22/11/01 SHEET: 1 OFF 5
 CHECKED: SHEET Iss: 1 DRG No. PCX-LC321C-1

TL4

