

KLARK TEKNIK GROUP

TECHNICAL BULLETIN

Walter Nash Road, Kidderminster, Worcestershire. DY11 7HJ. England

Tel: (44) (0) 1562 741515. Fax: (44) (0) 1562 745371



SIGNAL PROCESSING BY DEFINITION BETTER BY DESIGN DESIGNED FOR A PURE PERFORMANCE

Brand Midas	Reference Number 127	Date 17/04/2003	<input type="checkbox"/> Urgent
Product Legend	Serial Number Applied from 3361 onwards	Assembly L311 Master Module	<input type="checkbox"/> Recommended
			<input checked="" type="checkbox"/> Information Only

Subject

This modification stops the Output meters from disappearing completely when the LED dim is turned down.

Information

It has been observed that when the LED's are dimmed on the Legend the output meters extinguish completely. To change this so that the output meters dim in the same way as the inputs, the following modifications must be carried out.

LC311A Main Output Board

Change R1368 from a 150k 1% 0603 Metal Film resistor to a 100k 1% 0603 Metal Film resistor.
(Klark Teknik Part Number RES56-5E1R00)

LC321A Stereo I/P, GRP, MTX Main Board

Change R2411 from a 150k 1% 0603 Metal Film resistor to a 100k 1% 0603 Metal Film resistor.
(Klark Teknik Part Number RES56-5E1R00)

LC311C Aux Output Display Board

Change the following resistors from a 1k 1% 0603 Metal Film resistor to a 2k2 1% 0603 Metal Film resistor.
(Klark Teknik Part Number RES56-3E2R20)

R118, R121, R205, R208, R305, R308, R405, R408, R505, R508, R605, R608, R705, R708, R805, R807, R905, R908, R1005, R1008, R1105, R1108, R1205, R1208

LC321C Group Output Display Board

Change the following resistors from a 1k 1% 0603 Metal Film resistor to a 2k2 1% 0603 Metal Film resistor.
(Klark Teknik Part Number RES56-3E2R20)

R118, R121, R205, R208, R305, R308, R405, R408, R505, R508, R605, R608, R705, R708, R805, R807, R905, R908, R1005, R1008, R1105, R1108, R1205, R1208

Circuit Diagrams and market overlays are attached.

Other Information

Distributed

All Distributors

Date Distributed

09/06/2003

Legend Output Module Overview

The Output module assembly part number is ALC311-5 (If you order complete tested output modules it is part number L311). The individual sub assembly part numbers are displayed below.

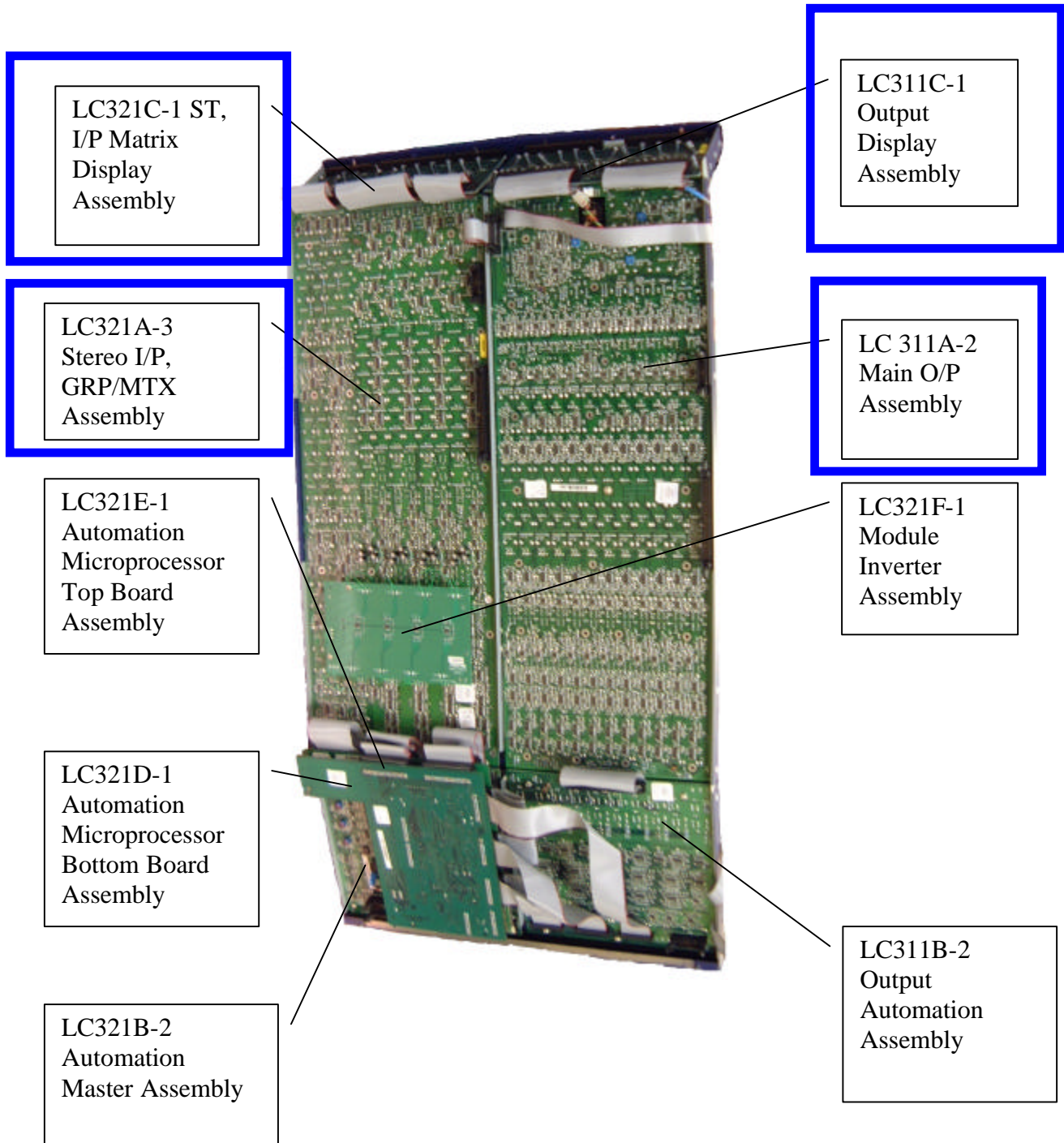

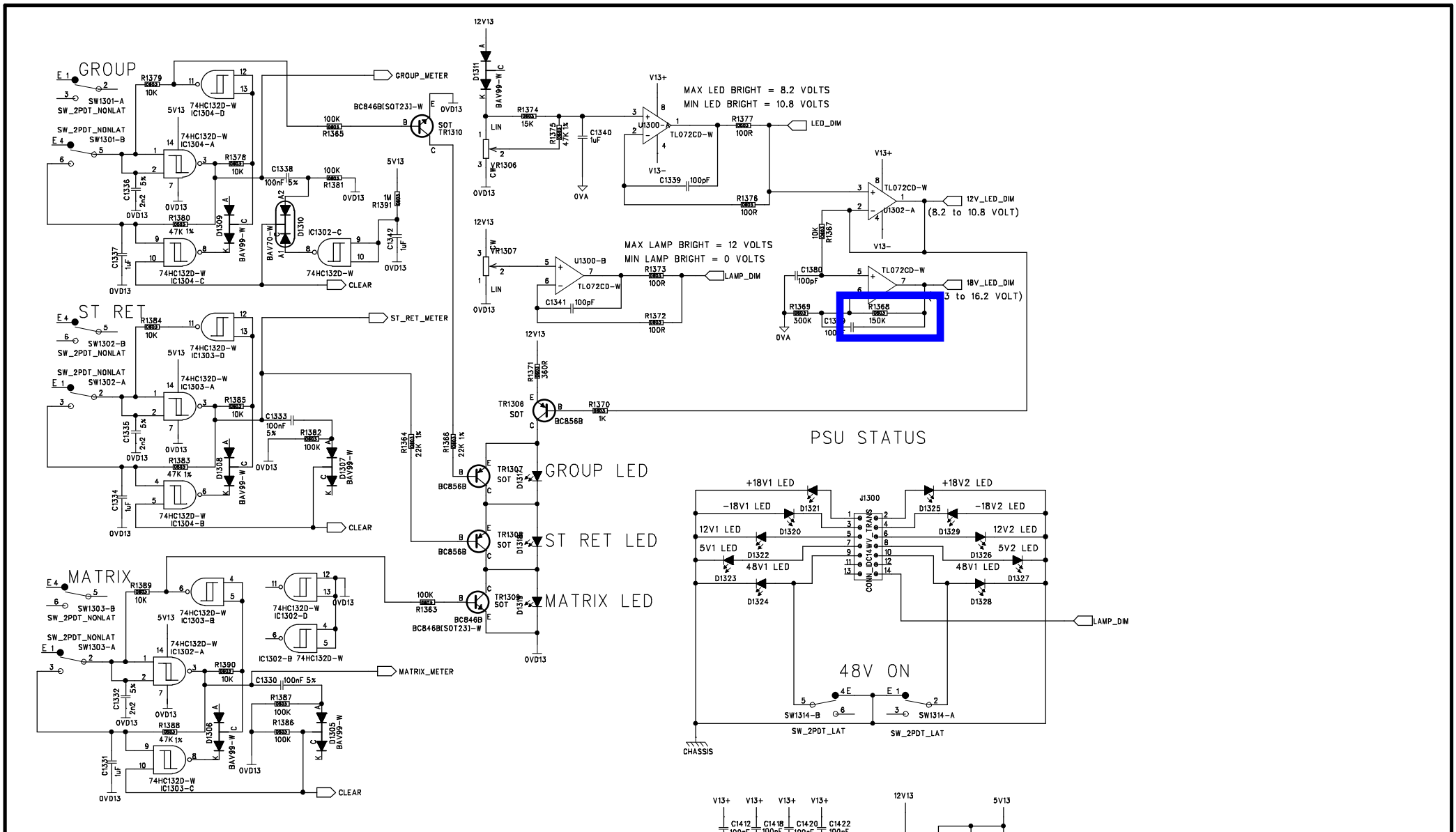

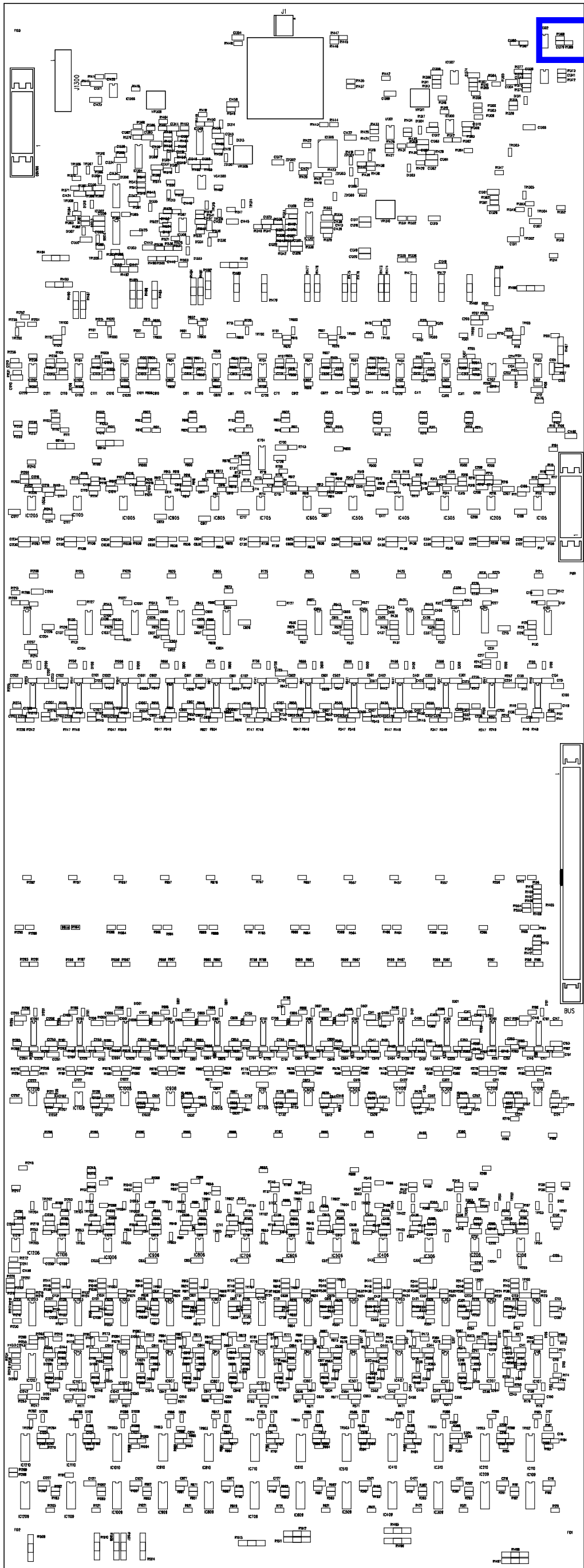

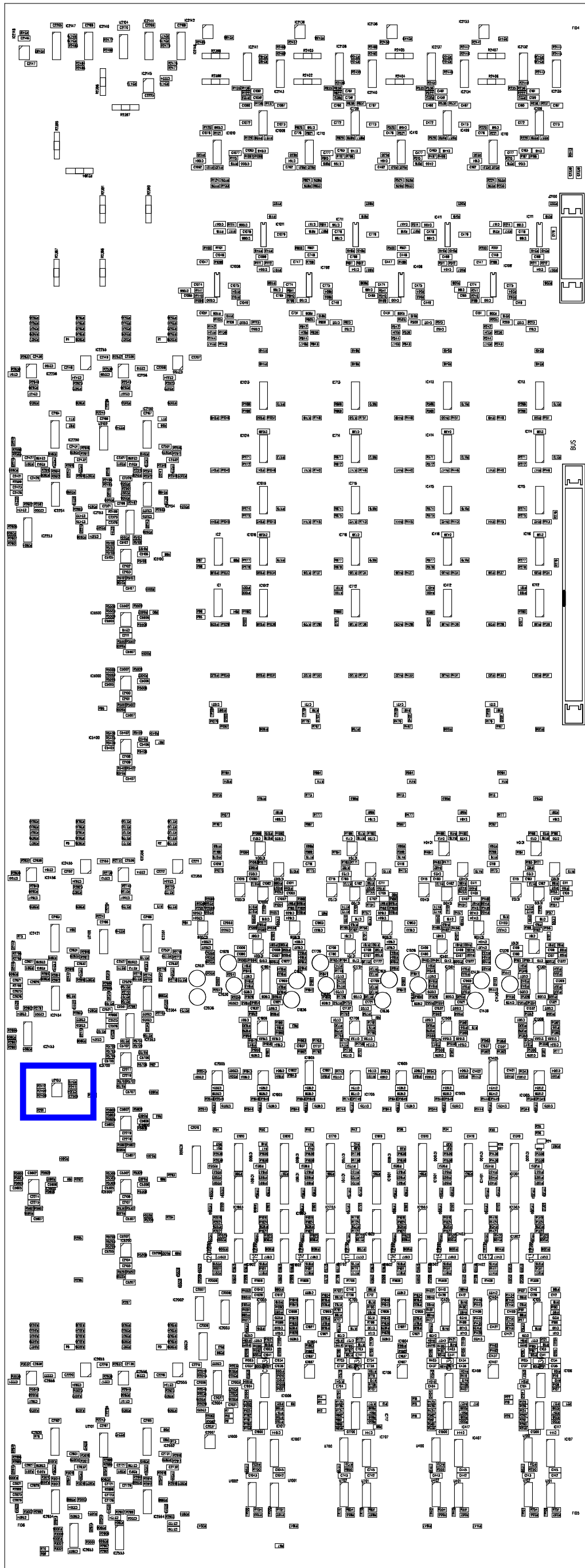

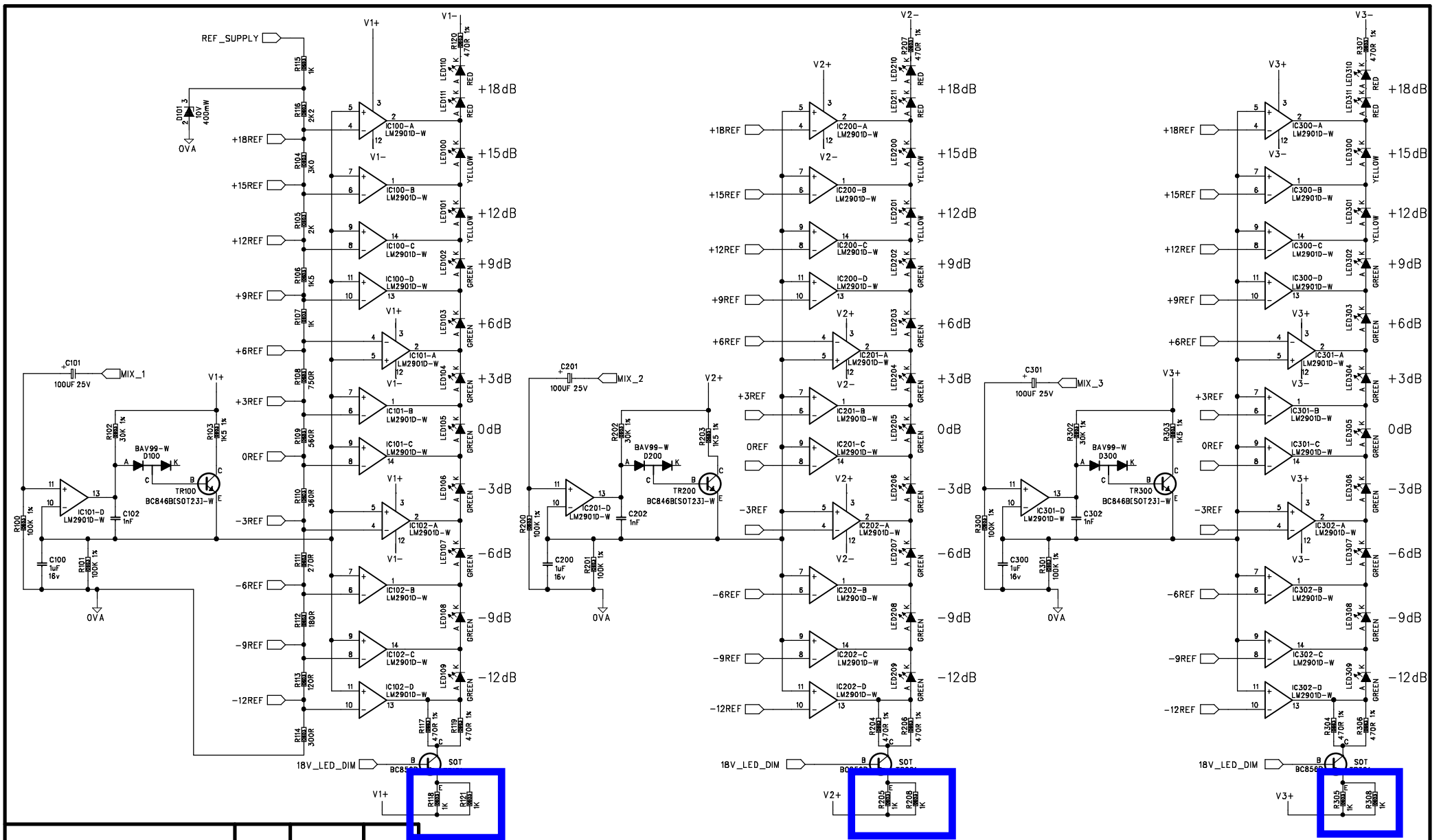

AMENDMENTS	ISS.	INIT.	DATE.

UNIT: LEGEND 3000
 TITLE: OUTPUT METERS 1-3
 BOARD No. LC311C BOARD Iss. 1

MIDAS AUDIO

DRAWN: MF/SM	DATE: 22/11/01	SHEET: 1 off 5
CHECKED:	SHEET Iss: 1	DRG No. PCX-LC311C-1

TL4

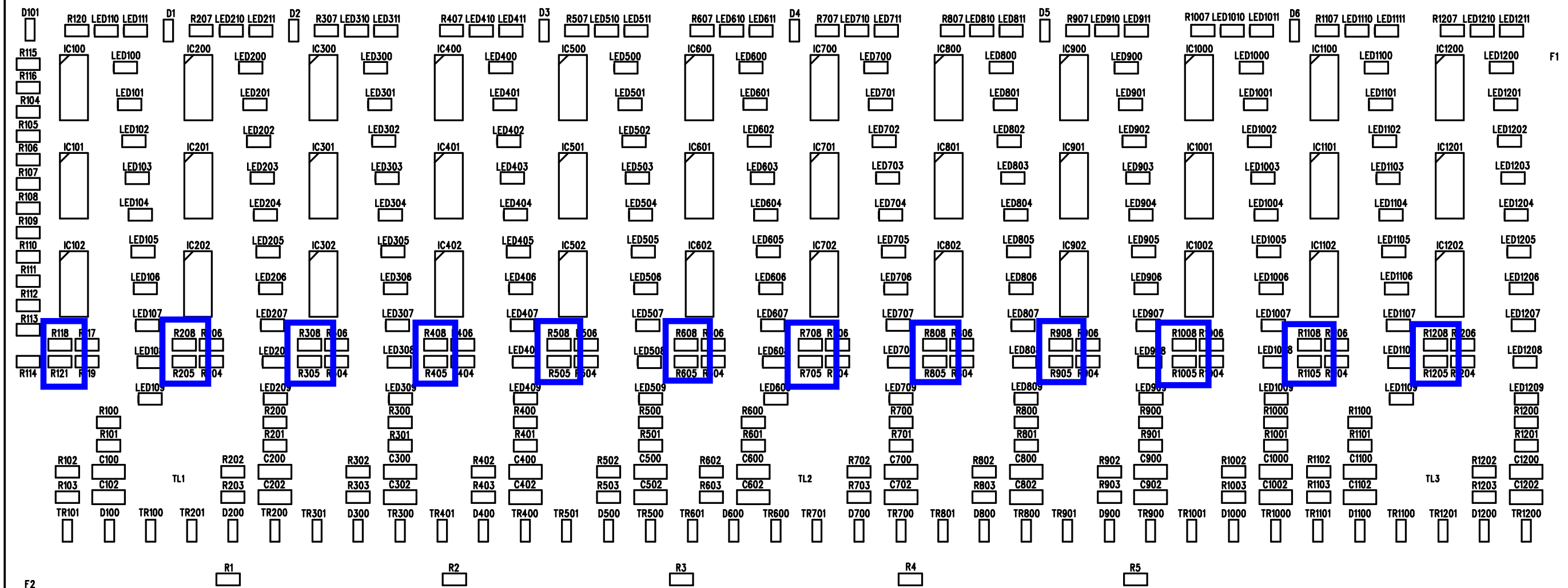

F1

F2

F3

TL5

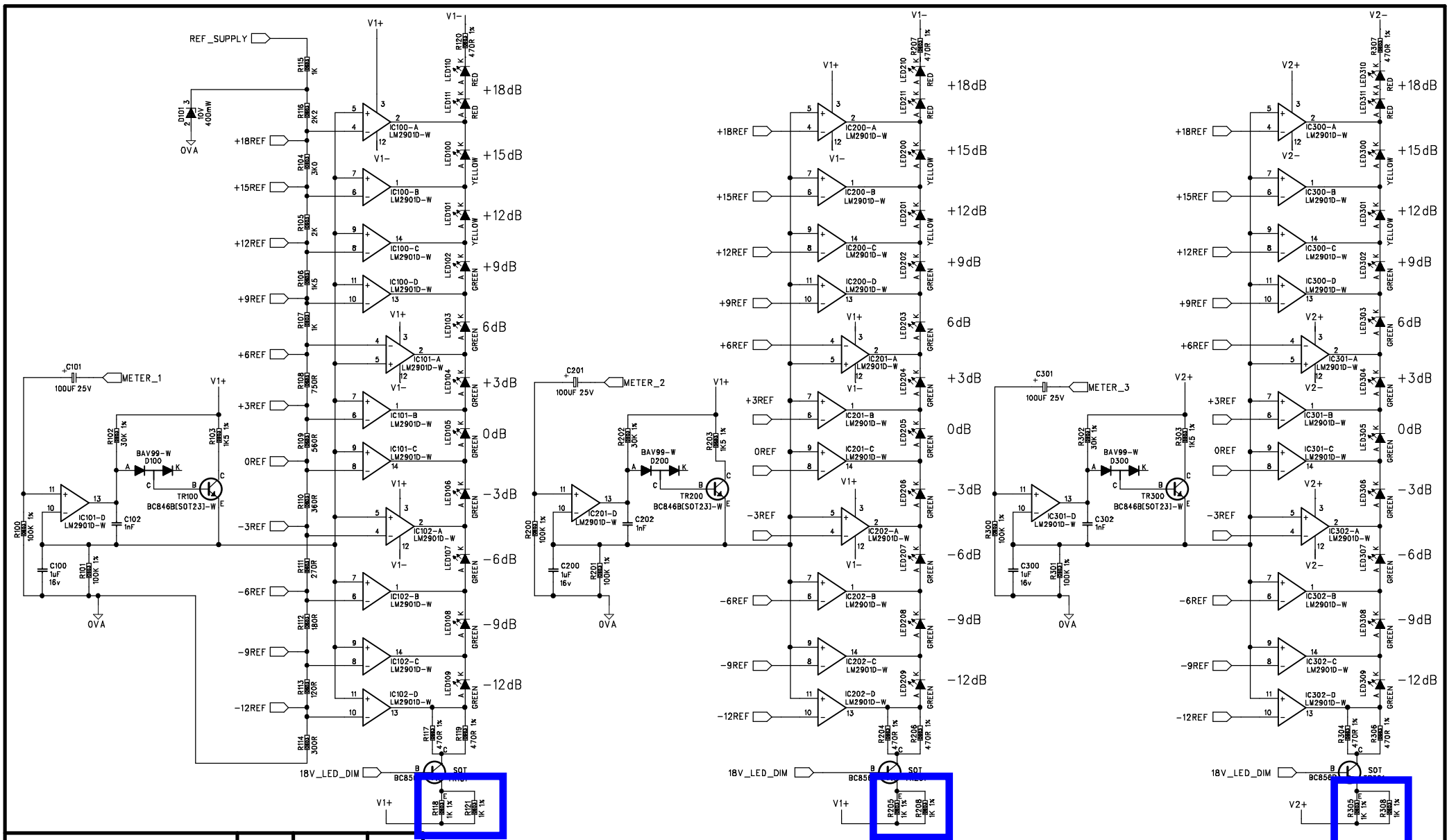

UNIT: LEGEND 3000

TITLE: MASTER METERS 1-3

BOARD No. LC321C BOARD Iss. 1

MIDAS AUDIO

DRAWN: MF/SM

DATE: 22/11/01

SHEET: 1 OFF 5

CHECKED:

SHEET Iss: 1

DRG No. PCX-LC321C-1

AMENDMENTS	ISS.	INIT.	DATE.

