

REVISIONS		DATE	APPROVED
ZONE	REV.	DESCRIPTION	
	B	CHANGED HOLE TO .688	1-13-06

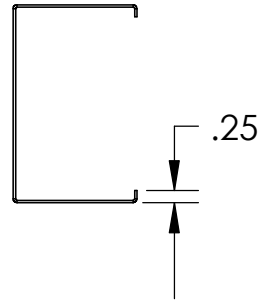

THIS UNIT TO BE ASSEMBLED WITH TWO 5F2EC END CAPS SPOT WELDED AND ENDCAP FLANGES POINTING INWARD ON CHASSIS.

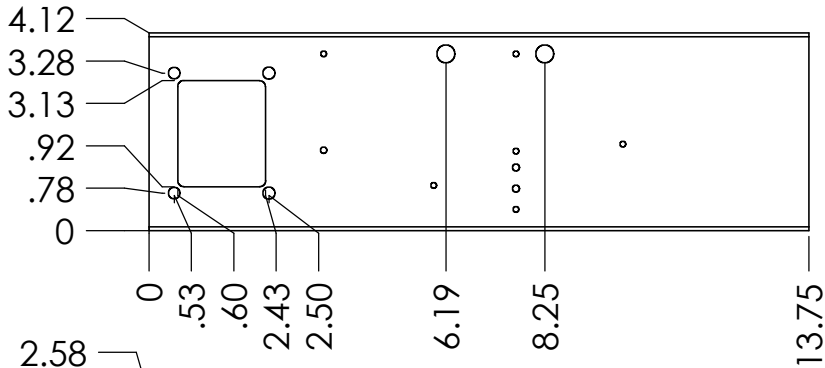
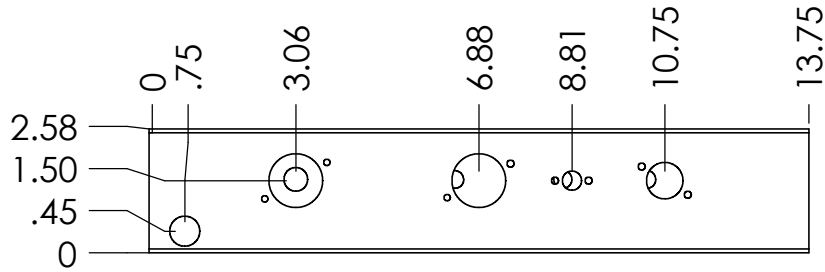
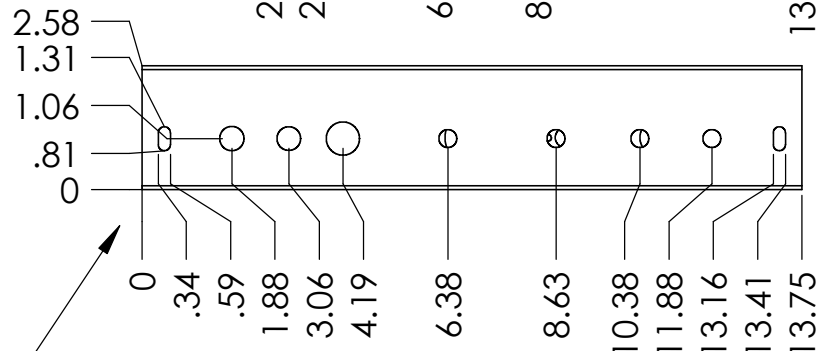
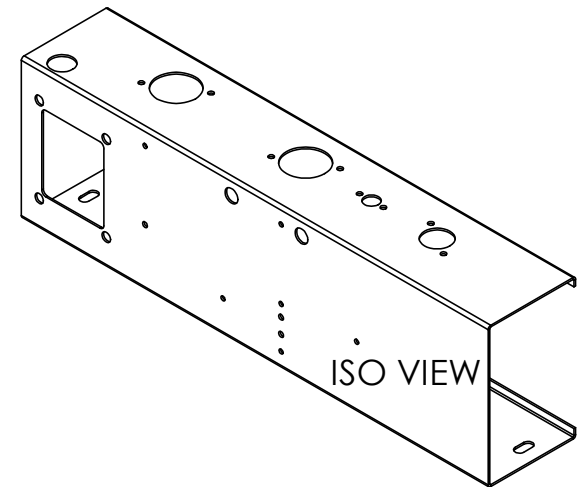

THIS FACE ON THE ASSEMBLED CHASSIS IS TO BE POLISHED TO A MIRROR FINISH BEFORE ASSEMBLY IS CHROME PLATED. FACE IS TO BE FREE OF SCRATCHES, SPOTTING, AND MISSOUTS.

PROPRIETARY AND CONFIDENTIAL
THE INFORMATION CONTAINED IN THIS DRAWING IS THE SOLE PROPERTY OF WeberVST. ANY REPRODUCTION IN PART OR AS A WHOLE WITHOUT THE WRITTEN PERMISSION OF WeberVST IS PROHIBITED.

		UNLESS OTHERWISE SPECIFIED:		NAME	DATE
		DIMENSIONS ARE IN INCHES	DRAWN	GA	1-13-06
		TOLERANCES:	CHECKED		
		FRACTIONAL ±	ENG APPR.		
		ANGULAR: ±1 BEND ±.030	MFG APPR.		
		TWO PLACE DECIMAL ±.015	Q.A.		
		THREE PLACE DECIMAL ±.010	COMMENTS:		
		INTERPRET GEOMETRIC TOLERANCING PER:			
		MATERIAL			
		18 GA CRS			
		FINISH			
		CHROME			
NEXT ASSY	USED ON				
APPLICATION	DO NOT SCALE DRAWING				

WeberVST		
TITLE:		
5F2 CHASSIS		
SIZE	DWG. NO.	REV
A	5F2CH-REVB	B
SCALE: 1:4	WEIGHT:	SHEET 1 OF 1