

June 27, 1933.

B. F. MIESSNER

1,915,858

METHOD AND APPARATUS FOR THE PRODUCTION OF MUSIC

Original Filed April 9, 1931 3 Sheets-Sheet 1

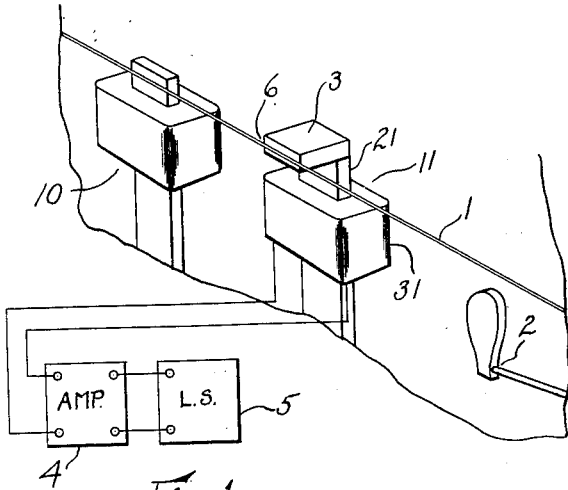

Fig. 1

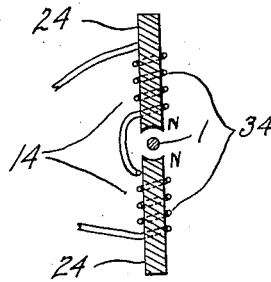

Fig. 4

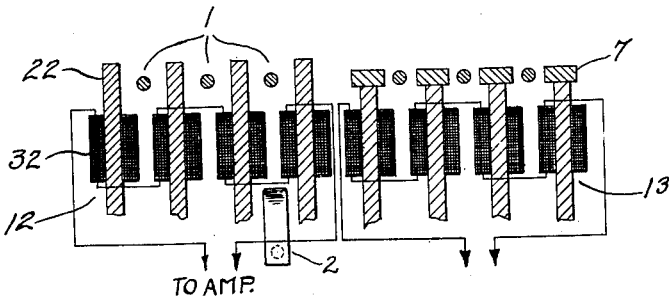

Fig. 2

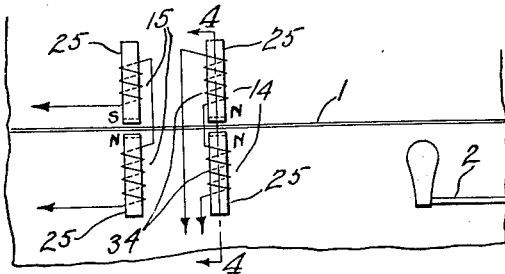

Fig. 3

Benjamin F. Miessner,
INVENTOR,

BY Charles J. Jacobs,
ATTORNEY.

June 27, 1933.

B. F. MIESSNER

1,915,858

METHOD AND APPARATUS FOR THE PRODUCTION OF MUSIC

Original Filed April 9, 1931. 3 Sheets-Sheet 2

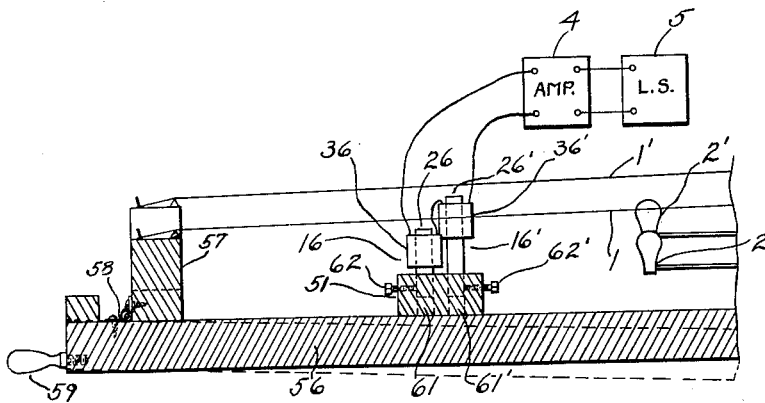

Fig. 5

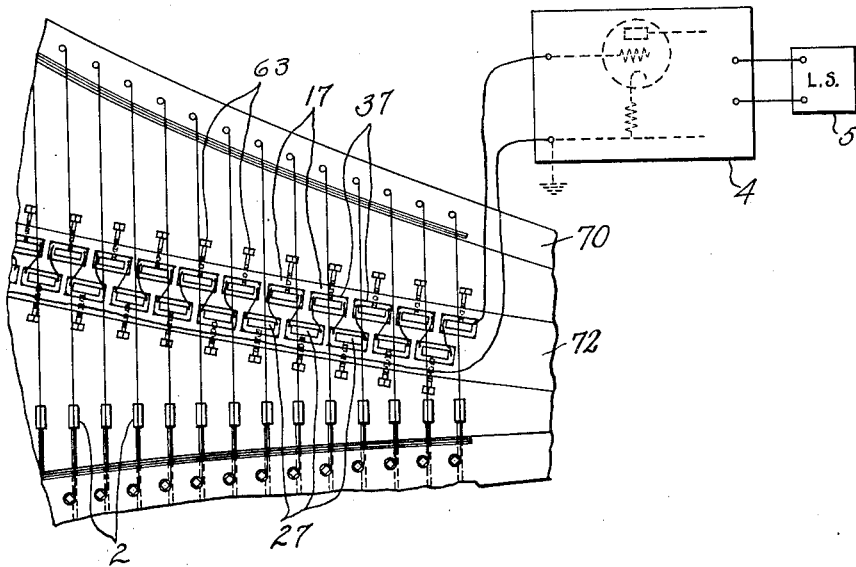

Fig. 6

Benjamin F. Miessner,
INVENTOR,

BY Charles T. Jacobs,
ATTORNEY.

June 27, 1933.

B. F. MIESSNER

1,915,858

METHOD AND APPARATUS FOR THE PRODUCTION OF MUSIC

Original Filed April 9, 1931 3 Sheets-Sheet 3

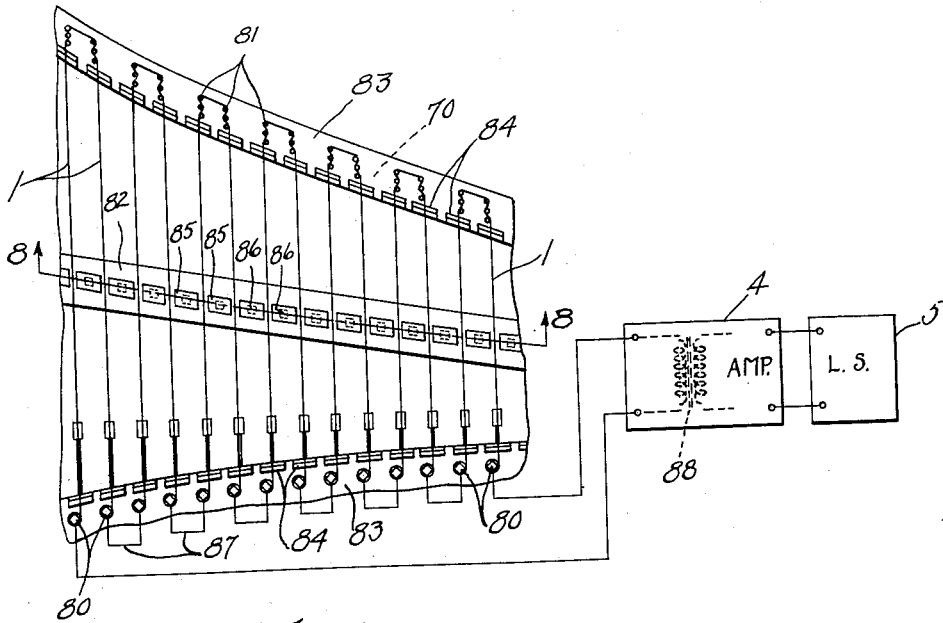

Fig. 7

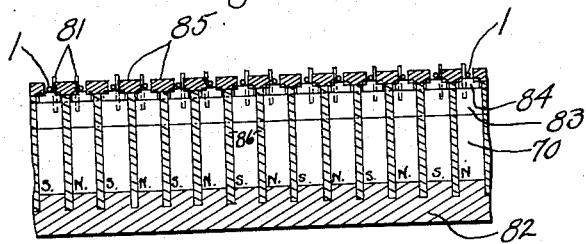

Fig. 8

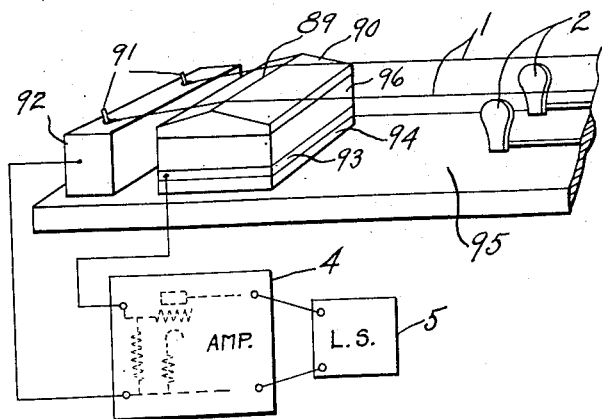

Fig. 9

Benjamin F. Miessner,
INVENTOR,

BY Charles T. Jacobs,
ATTORNEY.

UNITED STATES PATENT OFFICE

BENJAMIN F. MIESSNER, OF MILLBURN TOWNSHIP, ESSEX COUNTY, NEW JERSEY,
ASSIGNOR TO MIESSNER INVENTIONS, INC., A CORPORATION OF NEW JERSEY

METHOD AND APPARATUS FOR THE PRODUCTION OF MUSIC

Application filed April 9, 1931, Serial No. 528,750. Renewed August 5, 1932.

This invention relates to musical instruments and systems in which tuned vibrating bodies are used, their vibrations translated into electric oscillations, and such oscillations employed for the actuation of further apparatus and more specifically to mechanico-electric translating devices and their employment in such instruments and systems for translating the vibrations of the tuned bodies into electric oscillations. In my co-pending application, filed January 30, 1931, Serial Number 512,399, I have disclosed certain methods and apparatus of this nature, including several forms and uses of such translating devices. This application is in part a continuation of the above-mentioned, dealing with improvements in the electromagnetic translating devices and methods of employment therein described, as well as with alternative forms of translating device.

Although the methods and apparatus hereinafter disclosed are suitable for use with any form of tuned vibrating body, they are especially adaptable to use with strings. While the invention contemplates bodies excited into vibration in any manner, special consideration has been given to bodies excited by percussion, which excitation in instruments of the class described often entails certain peculiar problems. Prominent among these problems is that of the reduction of an undesirable rap or thud superimposed upon and occurring at the commencement of the tones produced by the individual bodies, particularly those tuned to higher vibration frequencies. Thus my invention has as a specific object the reduction or elimination of this rap and of other undesirable effects particularly likely to be encountered in the case of percussion excitation. A further specific object of my invention, equally important with any form of excitation; is the elimination of introduction of undesirable harmonics by the translating device in the oscillations therein generated.

A general object of my invention is the provision of improved devices and manner of employment thereof for translating the vibrations of tuned bodies into electric oscillations; and a further object is the provision

of improved means and methods, involving such translating devices, for adjusting the relative volume of the different tones, and for varying the volume of all the tones, produced in the output of an instrument or system of the class described. Other and allied objects will more fully appear from the following description and the appended claims.

In the detailed description of my invention hereinafter set forth, reference is had to the accompanying drawings, of which:—

Figure 1 is a perspective view of a single vibratory string provided with translating devices designed for the reduction of the rap effect abovementioned;

Figure 2 is a cross-sectional view of a group of strings provided with translating devices designed for the same purpose and for the elimination of spurious harmonic generation;

Figure 3 is a side view and Figure 4 a cross-sectional view of a string provided with translating devices designed for such spurious harmonic elimination and for the suppression of periodic oscillation amplitude variation;

Figure 5 is a side view of a plurality of strings provided with translating devices and means for manipulating the same for the control of the individual amplitude and the general amplitude of the electric oscillations generated therein;

Figure 6 is a plan view of a portion of an electrical musical instrument illustrating an alternative arrangement of translating devices;

Figure 7 is a plan view and Figure 8 a cross-sectional view of a portion of an electrical musical instrument employing a modified form of translating device; and

Figure 9 is a perspective view of a portion of a musical instrument employing a further modified form of translating device.

I have above referred to the phenomenon of rap frequently attendant upon the commencement of the tone produced by percussion excitation, particularly of strings, in an electrical musical instrument of the class described. In Figure 1 I show an arrangement of translating device with which this disturbance may be minimized. In this fig-

ure, 1 is a section of a string of magnetic material, such as the usual steel music string, which may be caused to vibrate by hammer 2, striking it from beneath. The translating device 11 is seen to consist of a bar magnet 21 having affixed thereto pole piece 3 separated from string 1 by gap 6, and carrying near such pole piece coil 31. The output terminals of coil 31, across which appears the output of the translating device, may be connected to the input terminals of an electrical amplifier 4, in the output circuit of which I show loudspeaker or other electro-acoustic translating device 5. An explanation of the reduction of rap by a translating device of this design is as follows:—

The magnet 21, the pole piece 3, the gap 6, the portion of the string near the pole piece, and the air path from such portion back to the lower end of magnet 21 in general form a magnetic circuit threading coil 31; and variations in the reluctance of this circuit, produced by variations of the gap 6, cause a voltage to be induced in coil 31, as will be understood. If the string be suddenly and appreciably moved directly toward or away from pole piece 3, a large transient voltage is set up in coil 31 and, amplified by 4 and translated into sound by 5, appears as the rap of which mention has been made. In Figure 1, however, it will be seen that the sudden and relatively large motion of string 1 which is the result of impact of hammer 2 is neither directly toward nor away from the pole piece, being parallel to its face. Thus the magnitude of the transient voltage is greatly reduced.

Should the string be caused by such impact to vibrate purely in a vertical direction, it is true that there would result poor efficiency of translation of its vibration into electric oscillation, and that such translation as occurred would be principally bicyclic. I have discovered, however, that in almost no case is it possible so to strike a string as to preclude the excitation of an appreciable component of vibration in a plane at right angles to the direction of striking—i. e., in a horizontal plane as shown in Figure 1—and that as a result the impairment of efficiency of action of the translating device is by no means as great as the reduction of the rap.

Various modifications of the design of this translating device may be made without impairing its efficacy in reducing rap. Thus, with reference to Figure 1, the magnet 21, carrying coil 31, may be mounted horizontally with its pole in the position in which the pole piece 3 is shown, the latter being omitted. Or, again, the pole piece may be omitted and the magnet raised slightly with respect to the string, so that its pole lies alongside and near to, but not pointed at, the string. This latter modification is illustrated by the translating device 10 drawn in Figure 1. Some

reduction in translating efficiency occurs with translating device 10, due to the positioning of the string in a less intense field; but the simplicity of the arrangement, particularly in an instrument employing a plurality of strings, has much to recommend it.

In Figure 2 I show a plurality of strings 1, which may if desired be parallel and in a single plane, and a plurality of the translating devices 12, comprising bar magnets 22 and coils 32 preferably connected in series. A single hammer 2 is shown, denoting a vertical striking direction; it will of course be understood that a hammer may be employed for each string if desired. In this arrangement the vibrations of each string 1 are translated by two of the devices 12, i. e., those on either side of the string. It is therefore important so to phase the coils and pole the magnets that the voltages induced by the vibration of each string in the two adjacent coils aid, and do not buck, each other; and the arrangement which I prefer for the accomplishment of this objective comprises similar poling of the magnets 22—i. e., the mounting of all with like poles up—similar placement of similarly wound coils 32 thereon, and connection of the bottom of the first coil to the bottom of the second, of the top of the second to the top of the third etc. as shown. Reversal of the polarity of any magnet, however, if accompanied by the reversal of the phase of its coil, will still not cause bucking induced voltages.

The large vertical component of the motion of any of the strings is in this case translated with even less efficiency than in that of the string shown in Figure 1, and is theoretically not translated at all if the two translating devices adjacent the string are symmetrical about it. This results from the arrangement of polarities and phases, which causes voltages induced by vertical vibration components to buck or oppose each other. Horizontal vibration components are present as before, however; and to these the arrangement shown is particularly responsive, a motion of the string toward one translating device and away from the other inducing voltages in the coils of the two devices which add. Modifications of translating devices in this arrangement may be made, one being illustrated by devices 13 in Figure 2, which differ from the devices 12 in that they are provided with pole pieces 7 which may be in the plane of the strings as shown.

The arrangement shown has the further advantage of eliminating the introduction of even harmonics by the translating device into the oscillations thereby generated. With certain translating devices motion of the string in one direction, corresponding for example with a positive electric oscillation peak, may produce a different change in reluctance and hence in oscillation peak

amplitude from the change and amplitude respectively produced by similar string motion in the opposite direction, corresponding in the same example to a negative oscillation peak. Thus the wave-form of the oscillations is rendered asymmetrical about the axis; and such asymmetry denotes, of course, the presence of even harmonics; which, since similar string motions in the two directions were assumed in the example, were not present in the string vibration. In Figure 2 the only distinction between motion of the string in the two horizontal directions is a difference in phase or sign of the oscillation peak thereby produced, the wave-form and amplitudes on each side of the mean position being symmetrical, owing to the symmetrical placement about the string of the two devices active in translating its vibration into electric oscillations.

Such benefits of spurious even harmonic elimination may be obtained in the case of strings and translating devices not specially arranged for elimination or reduction of raps. Thus in Figure 3 I show a string 1; hammer 2 arranged to excite it principally into vertical vibration, and devices 14 arranged for most efficient translation of such vertical string vibration. The devices 14 may consist of two bar magnets 24, one below and one above string 1, with similar poles of each adjacent the string. The poles are uniformly designated N by way of example. Coils 34, shown schematically, may surround magnets 24, a proper method of connection being such that the coils tend mechanically to form one continuous, similarly directed winding. Translating devices 15 are of an alternative form, wherein the phase of the upper coil 35 and the polarity of the upper magnet 25 have each been reversed. In the case of devices 15, magnets 25 may be replaced with pole pieces, and a single horse shoe magnet employed with one of its poles touching the top of the upper pole piece and the other the bottom of the lower pole piece.

It frequently happens that the vibration of strings, particularly of those not continuously excited, does not consist of, or may not be resolved into, relatively steady components at right angles to each other, such as horizontal and vertical components; but instead may be resolved into continuously varying such components, of which the vector sum is probably relatively steady. Thus the apparent plane of vibration may shift continuously, either as a continuous rotation of such plane about the mean position of the string as an axis or as a pendular oscillation of such plane back and forth about such axis. With most forms of translating device this action causes a continuous change in the amplitude of the electric oscillations produced, which may prove objectionable. I have found it desirable for the reduction or

elimination of this effect to curve or dish the pole of the magnet (or pole piece if employed) generally, though not necessarily exactly, following a section of a cylinder having the string as its axis. Thus in Figure 4 I show in cross-section string 1 and the translating devices 14 of Figure 3, the section being along line 4—4 of Figure 3. The ends of the magnets 24 of the translating devices 14 adjacent string 1 are seen to be dish or curved as described. It will be appreciated that the plane of vibration of the string may shift materially from the vertical without appreciable changing the relationship of the string at any given instant to the curved pole surfaces of the magnets 24. This curving of the pole surface may equally advantageously be employed with a single translating device such as either the lower or upper translating device 14.

Further details of my invention appear in Figure 5. In this figure 1 and 1' are sections of strings, excitable by hammers 2 and 2'. Underneath strings 1 and 1' are shown respectively translating devices 16 and 16', which may comprise magnets 26 and 26' and coils 36 and 36', the latter being preferably connected in series. While 1—2 and 1'—2' are shown respectively in different horizontal planes, 26 and 26' different in length, and 16 and 16' in different longitudinal positions, it will be understood that those differences need not exist, being incorporated in the figure for the sake of clear depiction. The translating devices 16 and 16' may be mounted in block 51, which is carried by base 56.

Base 56, although illustrated in its normal position, will also be seen to be hinged to string support 57 by hinge 58. This permits its movement away from the strings, as to the position shown in dotted lines; and handle 59 may be provided to facilitate such motion. When base 56 is so moved, block 51 and the translating devices are lowered in position away from the strings, resulting in uniformly decreased translation efficiency. Thus a general control of oscillation amplitude, or of output volume from loudspeaker 5, is provided by movement of the translating devices.

In Figure 5 I also show means for adjusting the amplitudes of the oscillations produced by the individual translating devices with base 56 in any given position and with any given amplitude of string vibration. The magnets 26 and 26' of the translating devices 16 and 16' are seen to be inserted in holes 61 and 61' in block 51; and they may be raised or lowered in such holes to any desired position and there secured by means of set screws 62 and 62'. Thus not only may inequalities in the amplitude of the oscillations produced by a given amplitude of vibration of the several strings be eliminated, but compensation may be effected for inequalities

in actuation mechanisms for the several strings and in the amplification efficiency of amplifier 2 and translation efficiency of loudspeaker 5 at different frequencies; furthermore special and unusual frequency-loudness characteristics may be thus imparted to the complete instrument if desired.

In Figure 6 I show a plan view of a staggered arrangement of translating devices. Here the strings 1 may be strung in a plane, as between the sides of a frame 70, and hammers 2 below the strings may be provided to excite the same.

To the frame 70, as to the bottom thereof, may be secured block 72, carrying a plurality of translating devices 17. These may each consist of a vertical bar magnet 27 carrying near its upper pole coil 37; and each magnet may be adjustably held in place in a hole in block 72 by a set screw 63. The magnets are preferably of wide, thin stock, and the coils are arranged in two rows, those in each row being staggered with respect to those in the other. The coils are preferably electrically connected in series so that all the translating devices produce similarly directed voltages in the common circuit for a given direction of motion of the strings, either upward or downward.

In Figure 6 I also show a preferred method of connection to an electrical amplifier 4 of a group of translating devices associated with different frequency strings. Of the input terminals of such an amplifier one is frequently effectively connected to ground either directly or through a low reactance or impedance, while the other is of relatively free potential. A typical illustration is an amplifying tube input, which is illustrated for example in dotted lines in the box of amplifier 4 in the figure, wherein one input terminal connects almost directly to the cathode system with its usual low or ground potential and the other to the grid of the tube, separated from any low potential by at least a very high value of resistance. It is highly desirable to connect to the free-potential input terminal—i. e., the grid of the tube in translating devices which is associated with the highest frequency strings; otherwise the efficiency of the instrument at such frequencies and their natural harmonics may be seriously impaired.

While in describing the foregoing embodiments of my invention I have shown electromagnetic translating devices, my invention is not peculiar thereto and I do not wish so to limit it, these embodiments being equally applicable to and useful with other forms of translating device, as will be understood.

In Figure 7 I show an alternative form of translating device in which no coils need be employed. With this form strings 1 may be used, strung from one tuning pin 80 to the

next, for example in a horizontal plane, over individual pressure bars 84 and around pins 81, respectively on and in insulating tops 83 of a frame 70. In a plane underneath that of the strings and in a line cutting across the strings may be placed bar 87 of magnetic material such as soft iron. Vertical bar magnets 86 may be fastened to bar 82, alternately poled; and to the top poles of the magnets 86 may be fastened pole pieces 85, lying in the plane of the strings. A cross sectional view of the assembly of Figure 7, taken along the line 8—8, appears as Figure 8. In this figure the letters N and S, alternately appearing by the lower poles of the magnets 86, denote their alternate polarity. The several strings are caused to form one continuous series circuit by the connections 87 appearing in Figure 7; and this circuit may be connected to the input terminals of an electrical amplifier 4, preferably including a step-up transformer 88. Loudspeaker 5, as in previous figures, is shown connected to the output terminals of amplifier 4.

Each of the strings will be seen to pass through a gap between two of the pole pieces 85. Each of these gaps contains a high flux, each gap being part of a magnetic circuit comprising the adjacent pole pieces, the magnets touching these poles, and the section of bar 82 between these magnets. Each string 1, being caused by its hammer 2 to vibrate with a large vertical component, cuts the magnetic lines in its gap and thus there is induced in the string an a. c. voltage of frequency corresponding to that of the string vibration. The a. c. voltage appearing in the string circuit as a result of the vibration of as many strings as may be simultaneously vibrating is stepped up by transformer 88, amplified by amplifier 4 and translated into sound by loudspeaker 5.

Various modifications of the arrangement illustrated in Figures 7 and 8 may of course be effected without departing from the spirit of the invention, which is intended to embrace the translation of the vibration of a tuned string into electric oscillations in the string by suitable placement of the latter in a steady magnetic field.

It will be seen that all the devices hereinabove disclosed are without moving or vibrating parts, and operate without mechanical connection to the vibrating body: they may therefore be classed as operatively stationary. In Figure 9, however, I show a translating device intended to function at the end of the active portion of a string or of each string in a group, and having an operating mechanical connection to the strings. As in prior figures, the strings and the hammers herein are respectively designated as 1 and 2. The strings are each passed over an edge 89 of electrically conductive block 90 and may be secured to pins 91 in electrically conduc-

5 tive block 92. The latter are so positioned
as to cause the strings by virtue of their ten-
sion to bear down upon the edge 89 of block
90; and this downward pressure is trans-
mitted to block 96, of piezo-electric material
such as quartz. Block 96 is thus placed in
compression between block 90 and electri-
cally conductive plate 93, which may be
mounted to and insulated from the base 95
by insulating block 94. The strings 1 are
electrically connected together and to block
92; and this may be connected to one input
terminal, preferably the ground or low
potential terminal, of electrical amplifier 4,
to the other input terminal of which may be
connected the plate 93.

This translating device makes use of the
property of the generation of voltage in, by
variation of pressure on, piezo-electric ma-
terial, the latter being in general substituted
for the bridge of the usual purely mechan-
ical and acoustical musical instrument, as
will be understood. In an instrument con-
taining a large number of strings a single
piezo-electric block for all strings, for each
group of strings, or for each string, may be
employed as desired.

It will be understood that while I have
shown and described the embodiments of my
invention in connection with strings, they
may readily be employed with other forms
of vibrators; and that various modifications
may of course be made in the choice and dis-
position of component parts without depart-
ing from the spirit or scope of my invention,
as hereinabove disclosed and in the append-
ed claims defined.

I claim:—

1. In a musical instrument, the combina-
tion of a tuned vibrator and means for pro-
ducing therefrom electric oscillations of
smooth initial amplitude rise, said means
comprising means for producing a deflection
of said vibrator, whereby the same is set into
vibration, and mechanico-electric translating
means sensitive to said vibration and rela-
tively insensitive to said initial deflection.

2. In a musical instrument, the combina-
tion of a tuned vibrator and means for pro-
ducing a sound of smooth inception there-
from, said means comprising means for ex-
citing said vibrator to initiate vibration
thereof, mechanico-electric translating means
energized by said vibrator, said translating
means being relatively insensitive to motions
of said vibrator immediately attendant upon
said excitation, and electro-acoustic translat-
ing apparatus connected to said mechanico-
electric translating means.

3. In a musical instrument, the combina-
tion of a tuned vibrator and means for pro-
ducing therefrom electric oscillations of
smooth initial amplitude rise, said means
comprising percussive means active in a given
plane for exciting said vibrator into vi-

bration, and mechanico-electric translating
means relatively unresponsive to components
of said vibration in said given plane and rela-
tively responsive to components in other
planes.

4. In a musical instrument, the combina-
tion of a tuned string and means for produc-
ing therefrom electric oscillations relatively
free of initial transients, said means compris-
ing a hammer adapted to strike said string
and mechanico-electric translating means en-
ergized by said string, said translating means
being relatively insensitive to motions of said
string immediately attendant upon such
striking.

5. In a musical instrument, the combina-
tion of a string; a hammer adapted to strike
said string; and a mechanico-electric trans-
lating device having a portion in spaced re-
lation to said string and operative in accord-
ance with vibratory variation of the spacing
between said string and the surface of said
portion, said portion being arranged without
the plane in which said hammer moves when
striking said string.

6. In a musical instrument, the combina-
tion of a string; a hammer adapted to strike
said string; and a mechanico-electric trans-
lating device having a portion in spaced re-
lation to said string and operative in accord-
ance with vibratory variation of the spacing
between said string and the surface of said
portion, said portion being arranged without
the plane in which said hammer moves when
striking said string, and said surface being
substantially parallel to said plane.

7. In a musical instrument, the combina-
tion of a succession of tuned vibratory bodies ly-
ing substantially in a plane; a mechanico-
electric translating system having portions
respectively positioned between each two
succeeding bodies and being arranged to
translate into electric oscillations components
of vibration of said bodies in said plane;
and a striker for each of said bodies movable
in a plane substantially different from said
first mentioned plane.

8. In a musical instrument, the combina-
tion of a tuned string; means for vibrating
said string; a mechanico-electric translating
device having a portion in spaced relation
to a section of said string and arranged to be
actuated by vibratory variation of such spac-
ing; and a curved surface on said portion,
said surface tending to follow a section of a
cylinder about the mean position of said
string as an axis.

9. In a musical instrument, the combina-
tion of a string; means for vibrating said
string; and a mechanico-electric translating
device having a portion arranged adjacent
and symmetrically to said string and opera-
tive in accordance with vibratory variation
of such spacing, the mid part of said portion
being recessed.

70

75

80

85

90

95

100

105

110

115

120

125

130

10. In a musical instrument, the combination of a plurality of tuned bodies; means for vibrating said bodies; mechanico-electric translating apparatus having a portion adjacent each of said bodies and being arranged to be actuated by vibratory changes in the distances between said bodies and said portions; and a single means connected to all of said portions for simultaneously and similarly adjusting the distances between said bodies and said portions.

11. A musical instrument comprising a plurality of tuned bodies; means for vibrating each of said bodies at a plurality of its partial frequencies; mechanico-electric translating apparatus for translating the vibrations of said bodies into electric oscillations, said apparatus having portions respectively adjacent said bodies and being arranged to be actuated by vibratory variation of the spacings between said bodies and said portions; electro-acoustic translating apparatus for translating said oscillations into sound; and means individually connected to the second said portions of said mechanico-electric translating apparatus for adjustably securing said portions, whereby the several said spacings may be individually adjusted.

12. The method of varying the output volume of a musical instrument of the type wherein the vibrations of tuned bodies are translated into electric oscillations by vibratory variation of the distances between said bodies and stationary translating apparatus, which consists in simultaneously and similarly varying the distances between said bodies and said apparatus.

13. The method of voicing a musical instrument of the type wherein the various partial frequency vibrations of each of a plurality tuned bodies are translated into sound by a mechanico-electro-acoustic translation process including the vibratory variation of the distances between said bodies and stationary translating apparatus, which method consists in selectively adjusting the distances between said bodies and said apparatus.

14. In a musical instrument, the combination of a tuned vibrator, two substantially similar operatively stationary mechanico-electric translating devices in substantially similar spaced relation to respectively opposite sides of a portion of said vibrator, and electrical connections between said translating devices whereby oscillations of the funda-

mental vibrational frequency of said vibrator respectively translated by said devices mutually aid.

15. In a musical instrument, the combination of a tuned vibratory body; means for maintaining a magnetic field transversely through a portion of said body between its extremities; means for vibrating said body in a plane substantially normal to said field; an electrical work circuit having two input terminals; and electrical connections between said two extremities of said body and said input terminals.

16. In a musical instrument, the combination of a plurality of tuned strings electrically connected in series to form a single circuit; means for maintaining a magnetic field transversely through each of said strings; means for vibrating each of said strings in a plane substantially normal to said field; an electrical work circuit having two input terminals; and electrical connections between the extremities of said string circuit and said input terminals.

17. In a musical instrument, the combination of a block of piezo-electric material; an electrically conductive member in contact with one face of said block; at least one tuned string exerting pressure upon a portion of said block opposite said face; means for vibrating said strings, whereby their pressure upon said block is oscillatorily varied; and means for translating into sound electric oscillations thereby generated in said block.

18. In a musical instrument, the combination of a plurality of progressively tuned vibratory bodies; means for vibrating said bodies; an electrical series of translating devices associated with said vibratory bodies, a first extremity of said series being associated with at least one of said bodies tuned to a low frequency and the second extremity with at least one of said bodies tuned to a high frequency; an electrical amplifier having an input terminal separated from ground by not more than a relatively low impedance and a second input terminal separated from ground by at least a relatively high impedance; and a connection from said first extremity of said series to said first amplifier input terminal and a connection from said second extremity to said second amplifier terminal.

BENJAMIN F. MIESSNER.

120

60

125

65

130