

Service Manual

DTR-2000/1000

CONTENTS

- 1) Structural Diagram: Page 2 -3
- 2) Circuit Diagram: Page 4-7
- 4) Test Mode: Page 8
- 5) Parts List: Page 9-12

1st Edition
Issued date: September 2nd, 2002
Issued by: KORG INC.

A

B

C

D

E

F

G

H

■製品外形寸法 単位; mm	
設計値	カタログ/取説公表寸法
481(W)x113(D)x45.5(H)	481(W)x113(D)x46(H)
■製品重量	
実測値	カタログ/取説公表寸法
1.35kg	1.4kg

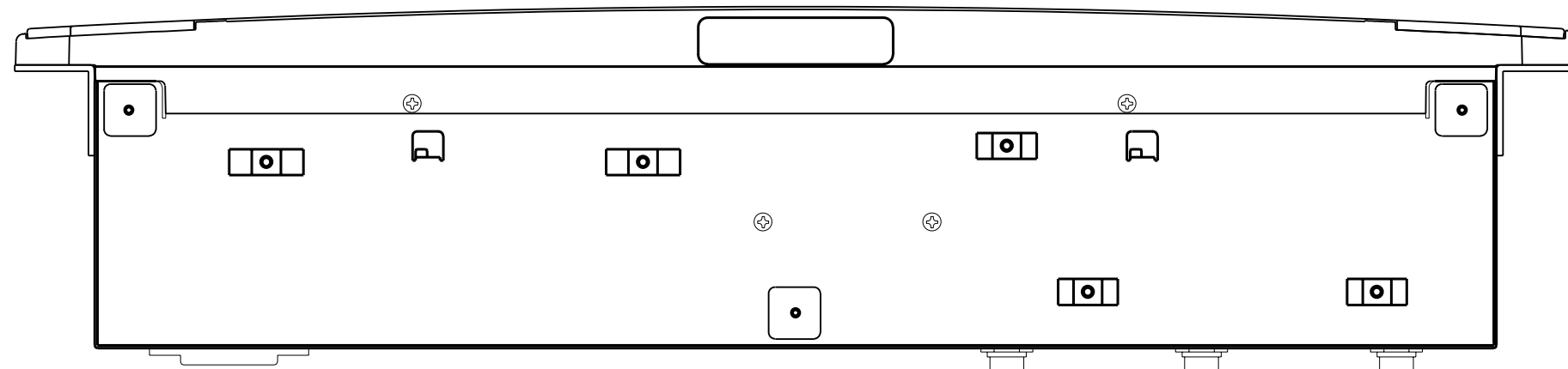
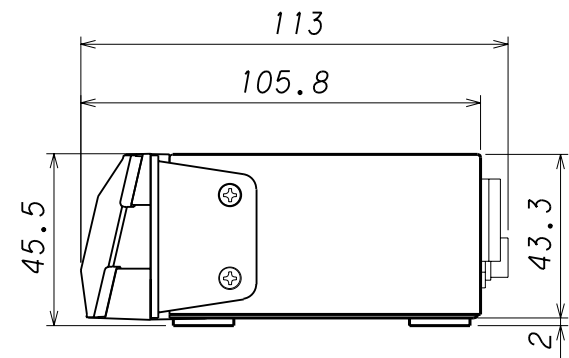
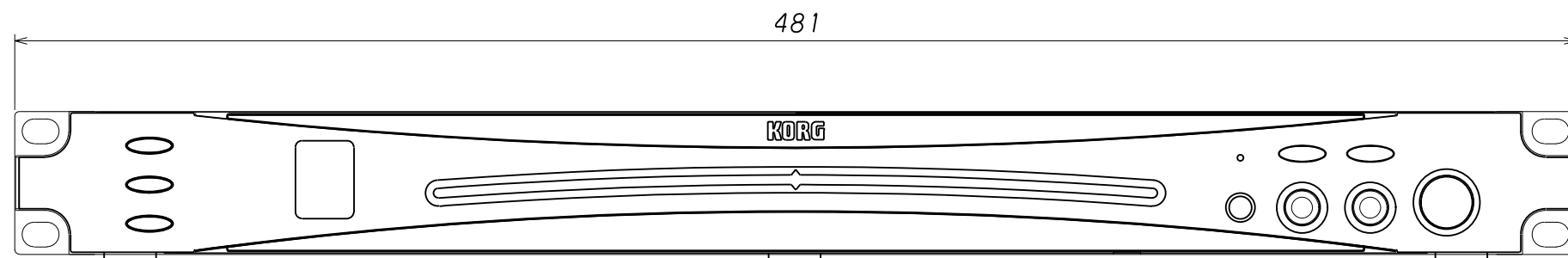
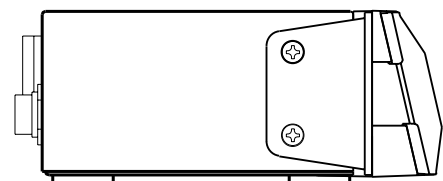
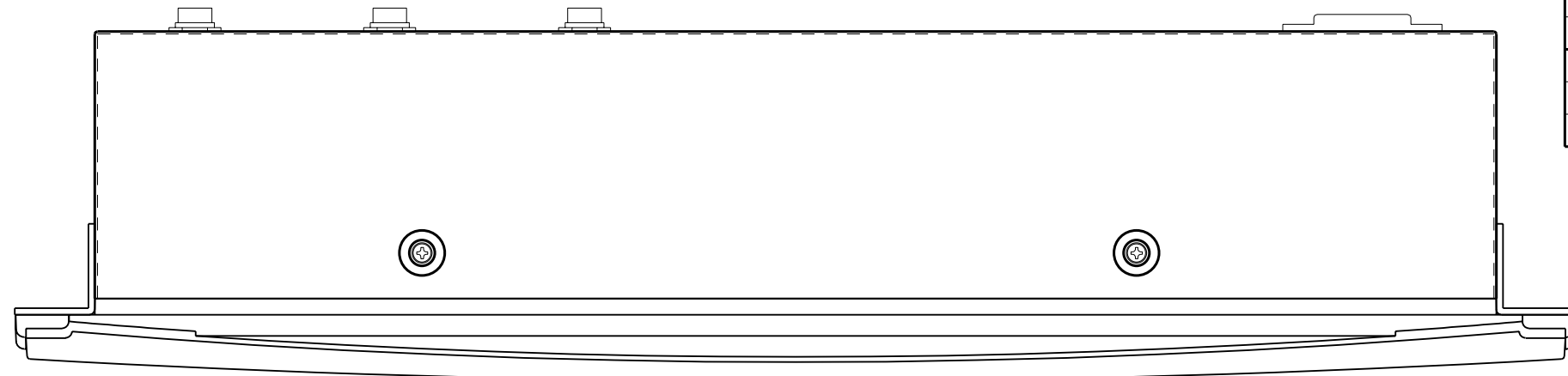

△				
△				
△				
△				
△				
△				
REVISAL MARK	REVISAL REASON	REVISAL DATE	REVISED BY	APPROVED

COMMERCIAL TOLERANCE ± mm

1	X-161L							
MODEL		SPECIFICATION			PARTS NAME		PARTS No.	
WEIGHT: *** (g)		DRAWN	CHECKED	APPROVED	TITLE DTR-2000 EXTERNAL APPEARANCE		試作図	
		S.Taguchi 2002.4.17	T.Shimokawa 2002.4.17	T.Adachi 2002.4.17	DTR-1000 外形図		金型手配図 金型発注図	
KORG KORG INC.				SCALE	DRAWING No.		量産図面	
				≠	KOC-A30156		総合製作書用図面	

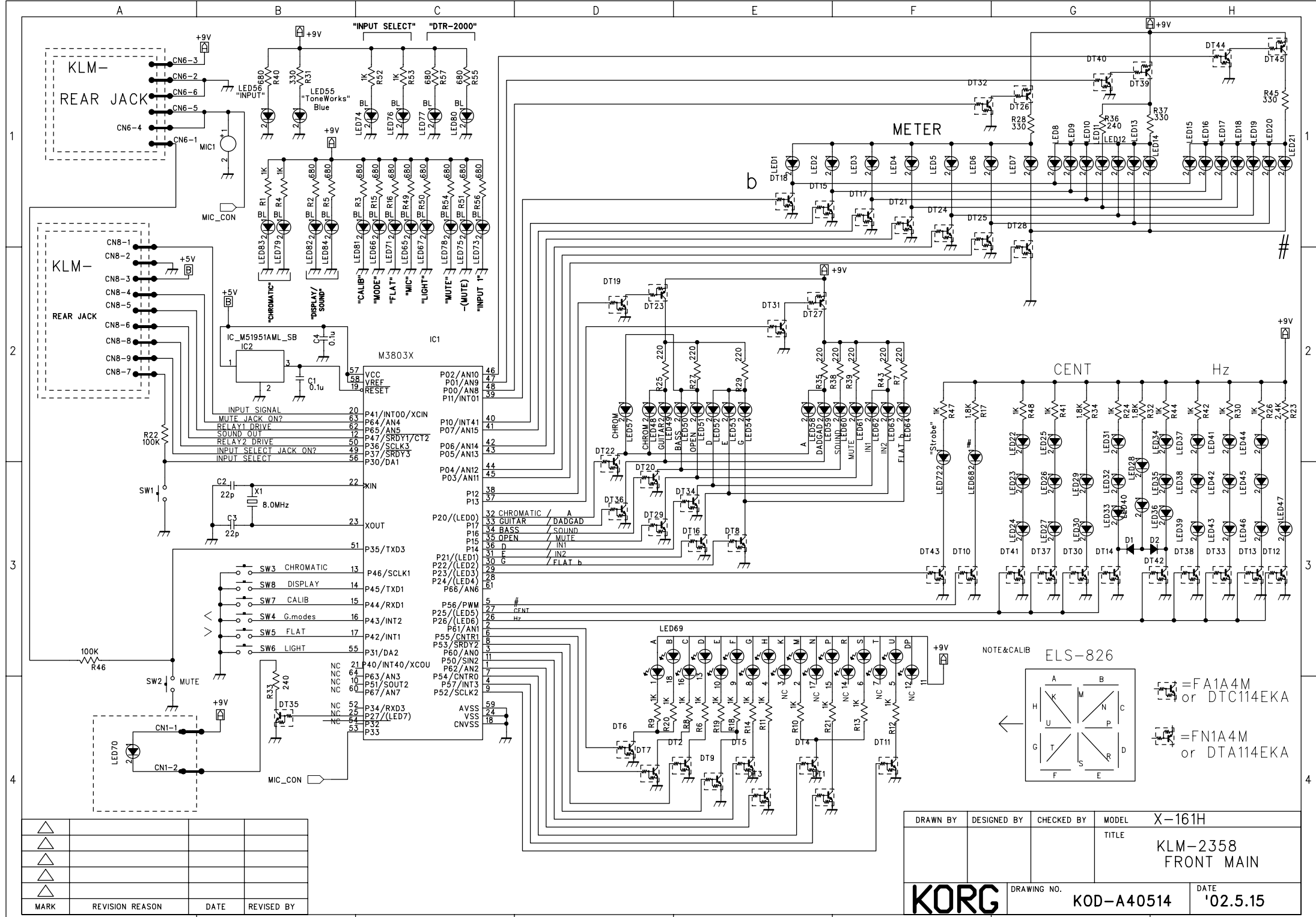

MARK	REVISION	REASON	DATE	REVISED BY
△				
△				
△				
△				

DRAWN BY	DESIGNED BY	CHECKED BY	MODEL	X-161H
			TITLE	KLM-2358 FRONT MAIN
KORG		DRAWING NO.	KOD-A40514	DATE
				'02.5.15

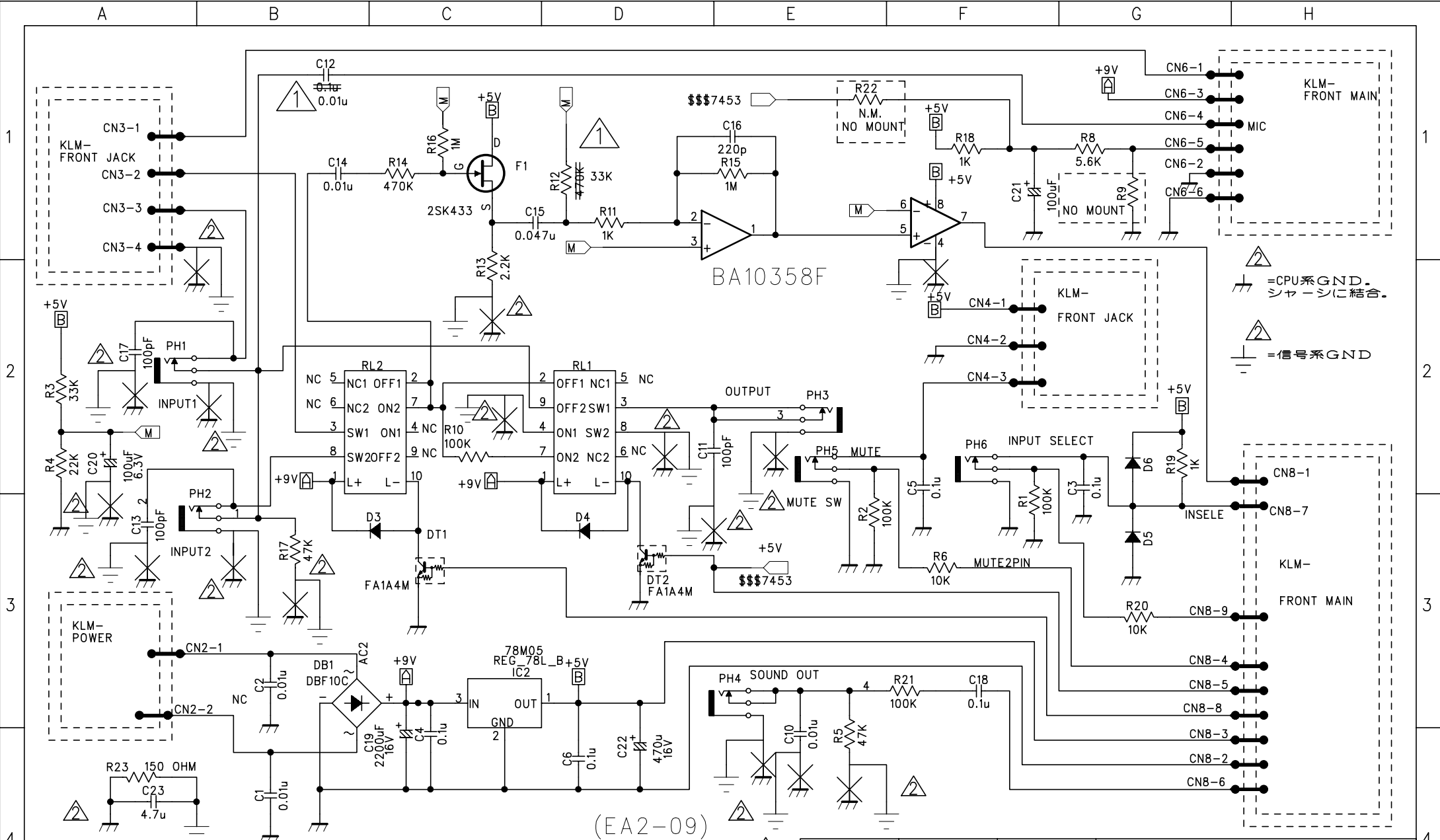

△	定数変更	'02.6.6	HIGO
△	信号GND分離(19箇所)	'02.7.19	HIGO
△			
△			
△			
MARK	REVISION REASON	DATE	REVISED BY

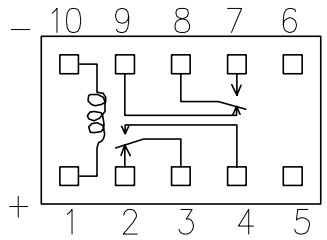

DRAWN BY	DESIGNED BY	CHECKED BY	MODEL	X-161H(DTR-2000)
			TITLE	KLM-2357_2 REAR JACK
KORG			DRAWING NO.	KOD-A40513
			DATE	'02.4.18

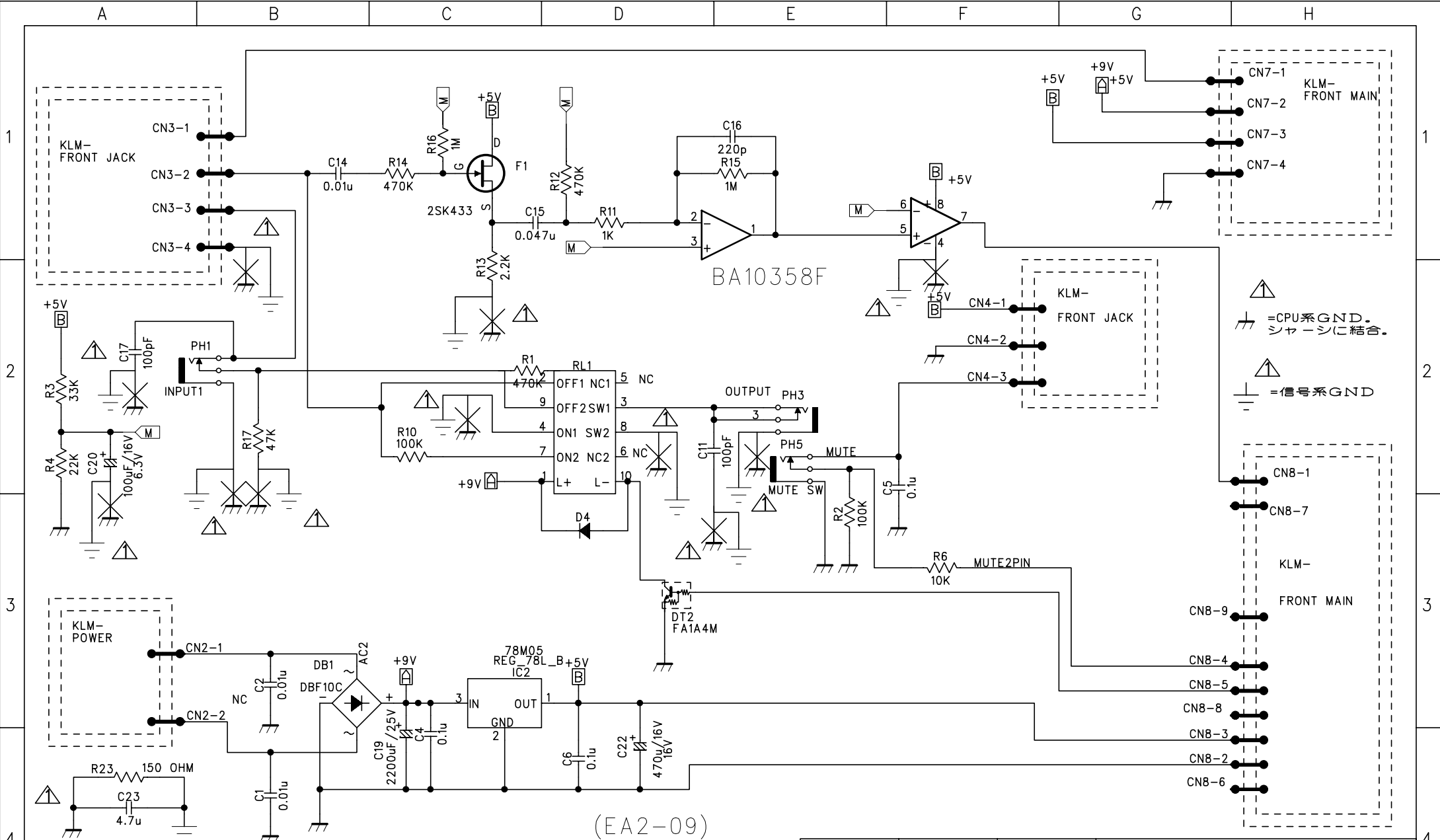

△ = CPU系GND.
 △ = シャーシに結合。
 ⊕ = 信号系GND

KLM-POWER

CN8-1
 CN8-7
 KLM-FRONT MAIN
 CN8-9
 CN8-4
 CN8-5
 CN8-8
 CN8-3
 CN8-2
 CN8-6

△	信号GND分離(14箇所)	'02.7.19	HIGO
△			
△			
△			
MARK	REVISION REASON	DATE	REVISED BY

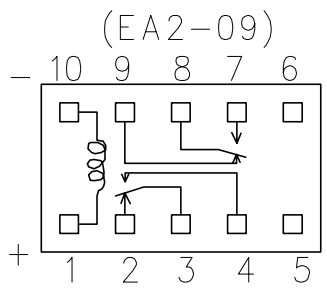

DRAWN BY	DESIGNED BY	CHECKED BY	MODEL	X-161L(DTR-1000)
			TITLE	KLM-2357_2 REAR JACK
KORG			DRAWING NO.	KOD-A40515
			DATE	'02.4.18

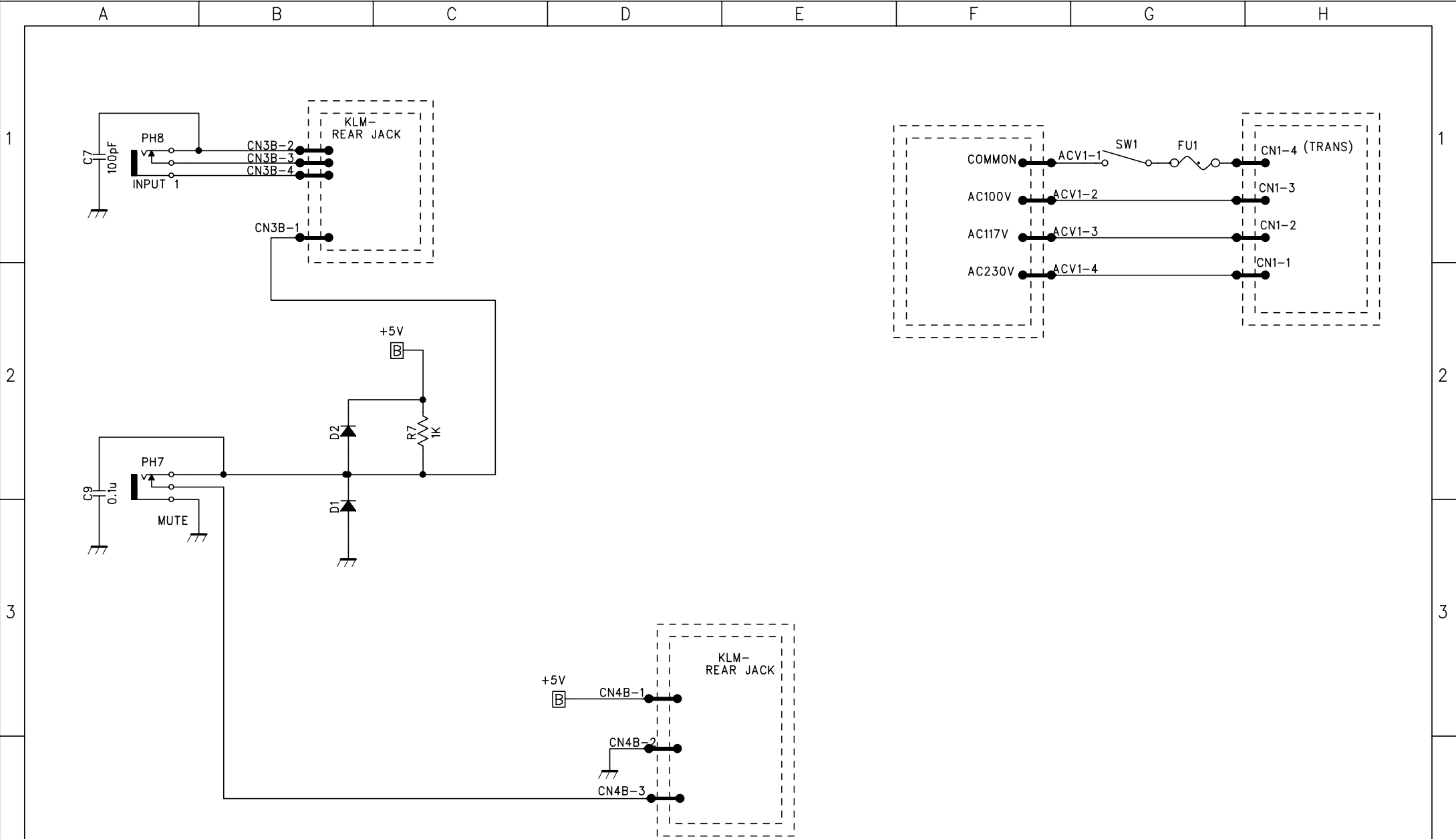

△			
△			
△			
△			
△			
MARK	REVISION REASON	DATE	REVISED BY

DRAWN BY	DESIGNED BY	CHECKED BY	MODEL X-161H/L(DTR-2000/1000)
			TITLE KLM-2356 FRONT JACK
KORG		DRAWING NO. KOD-A40518	DATE '02.4.18

DTR-1000

How to start the test mode

[DISPLAY] + [CALIB] & [POWER ON]

NOTE:

Do NOT insert any plug into the MUTE terminal while starting the test mode.

DTR-2000

How to start the test mode

[CHROMATIC] + [DISPLAY/SOUND] & [POWER ON]

NOTE:

Do NOT insert any plug into the MUTE and INPUT SELECT terminals while starting the test mode.

PART CODE	PART NAME	NOTE	Q'TY
001235600	PCB ASSY KLM-2356/57 DTR-2000	M.PART	1
001235800	PCB ASSY KLM-2358 DTR-2000	M.PART	1
304050140	DIGITAL TR DTC114EKA T146(TS)	KLM-2356/57 DT	2
304050140	DIGITAL TR DTC114EKA T146(TS)	KLM-2358 DTR-2	40
304050150	DIGITAL TR DTA114EKA T146 (TS)	KLM-2358 DTR-2	5
304060070	FET 2SK433-T12-1C (TS)	KLM-2356/57 DT	1
310011700	DIODE BRIDGE DBF10C	KLM-2356/57 DT	1
314001800	DIODE 1SS355 TE-17 (TS)	KLM-2356/57 DT	6
314001800	DIODE 1SS355 TE-17 (TS)	KLM-2358 DTR-2	2
320009062	IC NJM-78M05FA	KLM-2356/57 DT	1
320011216	IC M38034M4-297HP	KLM-2358 DTR-2	1
324011002	IC M5223FP-600C (TS)	KLM-2356/57 DT	1
324011016	IC M51951AML-600C (TS)	KLM-2358 DTR-2	1
335010600	CRYSTAL OSC HC-49US 8.00MHZ	KLM-2358 DTR-2	1
454004300	PHONE JACK YKB21-5012	KLM-2356/57 DT	6
454007900	PHONE JACK YKB21-5176 (GOLD)	KLM-2356/57 DT	2
471050201	CONNECTOR TOP B2P3-VH	KLM-2356/57 DT	1
471070200	CONNECTOR TOP B2B-PH-K-S	KLM-2358 DTR-2	1
471070300	CONNECTOR TOP B3B-PH-K-S	KLM-2356/57 DT	2
471070400	CONNECTOR TOP B4B-PH-K-S	KLM-2356/57 DT	2
471070600	CONNECTOR TOP B6B-PH-K-S	KLM-2358 DTR-2	1
471070600	CONNECTOR TOP B6B-PH-K-S	KLM-2356/57 DT	1
471070900	CONNECTOR TOP B9B-PH-K-S	KLM-2356/57 DT	1
472070900	CONNECTOR SIDE S9B-PH-K-S	KLM-2358 DTR-2	1
474022200	PIN HEADER B4P-LV-TN	KLM-2356/57 DT	1
540020200	INLET SOCKET SS-7B	M.PART	1
600003300	CORD UC-953-J01	M.PART 117CN	1
600003300	CORD UC-953-J01	M.PART 117US	1
600004700	CORD EC-652-E03	M.PART 230GE	1
600005300	CORD DC-480-J01	M.PART 100JP	1
600005800	CORD SC-111-J01	M.PART 240AU	1
*315X161H02	LED NSCW100 (WHITE)	KLM-2358 DTR-2	1
*315X161H03	LED 42-21SURC/S530-A2/TR8(RED)	KLM-2358 DTR-2	4
*315X161H04	LED ELS-826HWP DIGIT (RED)	KLM-2358 DTR-2	1
*315X161H05	LED 15-21 SRC/TR8(HT) (RED)	KLM-2358 DTR-2	76
*315X161H06	LED 15-21UBC/C470 (BLUE)	KLM-2358 DTR-2	2
*375X161H00	PSW KDC-A04-10(B)B1-G	KLM-2356/57 DT	1
*400X161H00	POWER TRANSFORMER TA-083	M.PART 117CN	1
*400X161H00	POWER TRANSFORMER TA-083	M.PART 117US	1
*400X161H00	POWER TRANSFORMER TA-083	M.PART 100JP	1
*400X161H01	POWER TRANSFORMER TB-083	M.PART 240AU	1
*400X161H01	POWER TRANSFORMER TB-083	M.PART 230GE	1
*400X161H01	POWER TRANSFORMER TB-083	M.PART 230UK	1
*403X161H00	RELAY EA2-9 NU	KLM-2356/57 DT	2
*410X161H00	CONDENCER MIC KUC2423	KLM-2358 DTR-2	1
*464X161H00	FUSE T125MA/250V	M.PART 117US	1
*464X161H00	FUSE T125MA/250V	M.PART 117CN	1

DTR-2000

PART CODE	PART NAME	NOTE	Q'TY
*464X161H00	FUSE T125MA/250V	M.PART 100JP	1
*464X161H01	FUSE T63MA/250V	M.PART 230GE	1
*464X161H01	FUSE T63MA/250V	M.PART 230UK	1
*464X161H01	FUSE T63MA/250V	M.PART 240AU	1
*471X161H00	CONNECTOR TOP B4P7-VH	KLM-2356/57 DT	1
*475X161H00	HARNESS HNS-2067	M.PART	1
*475X161H01	HARNESS HNS-2068	M.PART	1
*475X161H02	HARNESS HNS-3174	M.PART	1
*475X161H03	HARNESS HNS-2071	M.PART	1
*475X161H04	HARNESS HNS-2066	M.PART	1
*475X161H05	HARNESS HNS-3156	M.PART 100JP	1
*475X161H06	HARNESS HNS-3157	M.PART 117US	1
*475X161H06	HARNESS HNS-3157	M.PART 117CN	1
*475X161H07	HARNESS HNS-3158	M.PART 230GE	1
*475X161H07	HARNESS HNS-3158	M.PART 230UK	1
*475X161H07	HARNESS HNS-3158	M.PART 240AU	1
*500X161H00	X-161H LIGHT SW KOC-E40547	M.PART	1
*500X161H01	X-161H RUBBER SW-H-1 E30284	M.PART	1
*500X161H02	X-161H RUBBER SW-H-2 E30285	M.PART	1
*500X161H03	X-161H/L URETHANE LEG 161	M.PART	3
*500X161H04	X-161H RUBBER LEG KOC-F40957	M.PART	1
*540X161H00	X-161H/L SHIELD SHEET C41270	M.PART	1
*540X161H01	X-161H DIFFUSION SHEET 1	M.PART	1
*540X161H02	X-161H DIFFUSION SHEET 2	M.PART	1
*540X161H03	X-161H/L ISOLATION SHEET	M.PART	1
*600R36301	AC CORD KP-610 DTR-1	M.PART 230UK	1
*620X161H00	X-161H/L PSW KNOB KOC-E30287	M.PART	1
*630X161H00	X-161H WINDOW KOC-E20218	M.PART	1
*630X161H01	X-161H SHEET-H-1 KOC-F30092-1	M.PART	1
*630X161H02	X-161H SHEET-H-2 KOC-F30092-2	M.PART	1
*630X161H03	X-161H SHEER-H-3 KOC-F41005	M.PART	1
*641X161H00	X-161H/L PSW ANGLE KOC-C41257	M.PART	1
*641X161H01	X-161H/L COVER KOC-C10237	M.PART	1
*641X161H02	X-161H CHASSIS H KOC-C10238-1	M.PART	1
*641X161H03	X-161H/L ANGLE KOC-C41258	M.PART	2
*641X161H04	X-161H/L PANEL SUPPORT C41259	M.PART	2
*646X161H00	X-161H/L PANEL KOC-E10209	M.PART	1

PART CODE	PART NAME	NOTE	Q'TY
001235601	PCB ASSY KLM-2356/57 DTR-1000	M.PART	1
001235900	PCB ASSY KLM-2359 DTR-1000	M.PART	1
304050140	DIGITAL TR DTC114EKA T146(TS)	KLM-2356/57 DT	1
304050140	DIGITAL TR DTC114EKA T146(TS)	KLM-2359 DTR-1	14
304050150	DIGITAL TR DTA114EKA T146 (TS)	KLM-2359 DTR-1	3
304060070	FET 2SK433-T12-1C (TS)	KLM-2356/57 DT	1
310011700	DIODE BRIDGE DBF10C	KLM-2356/57 DT	1
314001800	DIODE 1SS355 TE-17 (TS)	KLM-2356/57 DT	3
320009062	IC NJM-78M05FA	KLM-2356/57 DT	1
320011217	IC M37540M4-178FP	KLM-2359 DTR-1	1
324011002	IC M5223FP-600C (TS)	KLM-2356/57 DT	1
324011016	IC M51951AML-600C (TS)	KLM-2359 DTR-1	1
335010600	CRYSTAL OSC HC-49US 8.00MHZ	KLM-2359 DTR-1	1
454004300	PHONE JACK YKB21-5012	KLM-2356/57 DT	5
471050201	CONNECTOR TOP B2P3-VH	KLM-2356/57 DT	1
471070300	CONNECTOR TOP B3B-PH-K-S	KLM-2356/57 DT	2
471070400	CONNECTOR TOP B4B-PH-K-S	KLM-2356/57 DT	3
471070400	CONNECTOR TOP B4B-PH-K-S	KLM-2359 DTR-1	1
471070500	CONNECTOR TOP B5B-PH-K-S	KLM-2356/57 DT	1
471070500	CONNECTOR TOP B5B-PH-K-S	KLM-2359 DTR-1	1
474022200	PIN HEADER B4P-LV-TN	KLM-2356/57 DT	1
540020200	INLET SOCKET SS-7B	M.PART	1
600003300	CORD UC-953-J01	M.PART 117CN	1
600003300	CORD UC-953-J01	M.PART 117US	1
600004700	CORD EC-652-E03	M.PART 230GE	1
600005300	CORD DC-480-J01	M.PART 100JP	1
600005800	CORD SC-111-J01	M.PART 240AU	1
*315X161H03	LED 42-21SURC/S530-A2/TR8(RED)	KLM-2359 DTR-1	4
*315X161H04	LED ELS-826HWB DIGIT (RED)	KLM-2359 DTR-1	1
*315X161H05	LED 15-21 SRC/TR8(HT) (RED)	KLM-2359 DTR-1	20
*315X161L00	LED 15-21 VGC/TR8 (GREEN)	KLM-2359 DTR-1	1
*320X161L00	IC TC4S11F	KLM-2359 DTR-1	1
*375X161H00	PSW KDC-A04-10(B)B1-G	KLM-2356/57 DT	1
*400X161L00	POWER TRANSFORMER TA-082	M.PART 100JP	1
*400X161L00	POWER TRANSFORMER TA-082	M.PART 117CN	1
*400X161L00	POWER TRANSFORMER TA-082	M.PART 117US	1
*400X161L01	POWER TRANSFORMER TB-082	M.PART 230GE	1
*400X161L01	POWER TRANSFORMER TB-082	M.PART 230UK	1
*400X161L01	POWER TRANSFORMER TB-082	M.PART 240AU	1
*403X161H00	RELAY EA2-9 NU	KLM-2356/57 DT	1
*464X161H01	FUSE T63MA/250V	M.PART 230GE	1
*464X161H01	FUSE T63MA/250V	M.PART 230UK	1
*464X161H01	FUSE T63MA/250V	M.PART 240AU	1
*464X161L00	FUSE T80MA/250V	M.PART 100JP	1
*464X161L00	FUSE T80MA/250V	M.PART 117CN	1
*464X161L00	FUSE T80MA/250V	M.PART 117US	1
*471X161H00	CONECTOR TOP B4P7-VH	KLM-2356/57 DT	1

DTR-1000

PART CODE	PART NAME	NOTE	Q'TY
*475X161H00	HARNESS HNS-2067	M.PART	1
*475X161H05	HARNESS HNS-3156	M.PART 100JP	1
*475X161H06	HARNESS HNS-3157	M.PART 117CN	1
*475X161H06	HARNESS HNS-3157	M.PART 117US	1
*475X161H07	HARNESS HNS-3158	M.PART 230GE	1
*475X161H07	HARNESS HNS-3158	M.PART 230UK	1
*475X161H07	HARNESS HNS-3158	M.PART 240AU	1
*475X161L00	HARNESS HNS-2066 DTR-1000	M.PART	1
*475X161L01	HARNESS HNS-2136	M.PART	1
*475X161L02	HARNESS HNS-2137	M.PART	1
*500X161H03	X-161H/L URETHANE LEG 161	M.PART	3
*500X161L01	X-161L RUBBER SW L-1 E30286	M.PART	1
*500X161L02	X-161L RUBBER SW L-2 E40546	M.PART	1
*540X161H00	X-161H/L SHIELD SHEET C41270	M.PART	1
*540X161H03	X-161H/L ISOLATION SHEET	M.PART	1
*600R36301	AC CORD KP-610 DTR-1	M.PART 230UK	1
*620X161H00	X-161H/L PSW KNOB KOC-E30287	M.PART	1
*630X161L00	X-161L WINDOW KOC-E20219	M.PART	1
*630X161L01	X-161L SHEET L-1 KOC-F30092-3	M.PART	1
*630X161L02	X-161L SHEET L-2 KOC-F30092-4	M.PART	1
*630X161L03	X-161L SHEET L-3 KOC-F41004	M.PART	1
*641X161H00	X-161H/L PSW ANGLE KOC-C41257	M.PART	1
*641X161H01	X-161H/L COVER KOC-C10237	M.PART	1
*641X161H03	X-161H/L ANGLE KOC-C41258	M.PART	2
*641X161H04	X-161H/L PANEL SUPPORT C41259	M.PART	2
*641X161L02	X-161L CHASSIS L KOC-C10238-2	M.PART	1
*646X161H00	X-161H/L PANEL KOC-E10209	M.PART	1