

PC2 Series

Service Manual

KURZWEIL
Music Systems

©2004 All rights reserved. Kurzweil is a product line of Young Chang Co.; Kurzweil is a trademark of Young Chang Co. All other products and brand names are trademarks or registered trademarks of their respective companies. Product features and specifications are subject to change without notice.

Part Number: 910395 Rev. A

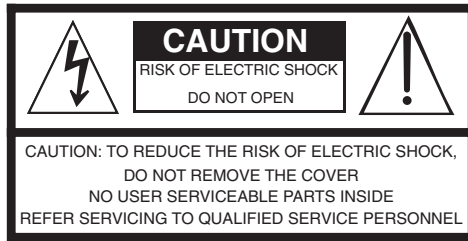

The lightning flash with the arrowhead symbol, within an equilateral triangle is intended to alert the user to the presence of uninsulated "dangerous voltage" within the product's enclosure that may be of sufficient magnitude to constitute a risk of electric shock to persons.



The exclamation point within an equilateral triangle is intended to alert the user to the presence of important operating and maintenance (servicing) instructions in the literature accompanying the product.

IMPORTANT SAFETY & INSTALLATION INSTRUCTIONS

INSTRUCTIONS PERTAINING TO THE RISK OF FIRE, ELECTRIC SHOCK, OR INJURY TO PERSONS

WARNING: When using electric products, basic precautions should always be followed, including the following:

1. Read all of the Safety and Installation Instructions and Explanation of Graphic Symbols before using the product.
2. Do not use this product near water—for example, near a bathtub, washbowl, kitchen sink, in a wet basement, or near a swimming pool, or the like.
3. This product should be used only with a stand or cart that is recommended by the manufacturer.
4. This product, either alone or in combination with an amplifier and speakers or headphones, may be capable of producing sound levels that could cause permanent hearing loss. Do not operate for a long period of time at a high volume level or at a level that is uncomfortable. If you experience any hearing loss or ringing in the ears, you should consult an audiologist.
5. The product should be located so that its location or position does not interfere with its proper ventilation.
6. The product should be located away from heat sources such as radiators, heat registers, or other products that produce heat.
7. The product should be connected to a power supply only of the type described in the operating instructions or as marked on the product.
8. This product may be equipped with a polarized line plug (one blade wider than the other). This is a safety feature. If you are unable to insert the plug into the outlet, contact an electrician to replace your obsolete outlet. Do not defeat the safety purpose of the plug.
9. The power supply cord of the product should be unplugged from the outlet when left unused for a long period of time. When unplugging the power supply cord, do not pull on the cord, but grasp it by the plug.
10. Care should be taken so that objects do not fall and liquids are not spilled into the enclosure through openings.
11. The product should be serviced by qualified service personnel when:
 - A. The power supply cord or the plug has been damaged;
 - B. Objects have fallen onto, or liquid has been spilled into the product;
 - C. The product has been exposed to rain;
 - D. The product does not appear to be operating normally or exhibits a marked change in performance;
 - E. The product has been dropped, or the enclosure damaged.
12. Do not attempt to service the product beyond that described in the user maintenance instructions. All other servicing should be referred to qualified service personnel.
13. **WARNING:** Do not place objects on the product's power supply cord, or place the product in a position where anyone could trip over, walk on, or roll anything over cords of any type. Do not allow the product to rest on or be installed over cords of any type. Improper installations of this type create the possibility of a fire hazard and/or personal injury.

RADIO AND TELEVISION INTERFERENCE

WARNING: Changes or modifications to this instrument not expressly approved by Young Chang could void your authority to operate the instrument.

IMPORTANT: When connecting this product to accessories and/or other equipment use only high quality shielded cables.

NOTE: This instrument has been tested and found to comply with the limits for a Class A digital device, pursuant to Part 15 of the FCC Rules. These limits are designed to provide reasonable protection against harmful interference when the instrument is used in a commercial environment. This instrument generates, uses, and can radiate radio frequency energy and, if not installed and used in accordance with the instruction manual, may cause harmful interference to radio communications. Operation of this instrument in a residential area is likely to cause harmful interference, in which case the user will be required to correct the interference at his or her own expense.

Changes and modifications not expressly approved by the manufacturer

or registrant of this instrument can void the user's authority to operate this instrument under Federal Communications Commission rules.

In order to maintain compliance with FCC regulations, shielded cables must be used with this instrument. Operation with unapproved equipment or unshielded cables is likely to result in harmful interference to radio and television reception.

NOTICE

This apparatus does not exceed the Class A limits for radio noise emissions from digital apparatus set out in the Radio Interference Regulations of the Canadian Department of Communications.

AVIS

Le présent appareil numérique n'émet pas de bruits radioélectriques dépassant les limites applicables aux appareils numériques de la class A prescrites dans le Règlement sur le brouillage radioélectrique édicté par le ministère des Communications du Canada.

SAVE THESE INSTRUCTIONS

Young Chang Distributors

Contact the nearest Young Chang office listed below to locate your local Young Chang/Kurzweil representative.

A N D Music Corp.

P.O. Box 99995

Lakewood, WA 98499-0995

Tel: (253) 589-3200

Fax: (253) 984-0245

Young Chang Akki Co., Ltd.

178-55 Gajwa-Dong

Seo-Ku, Inchon

Korea 404-250

Tel: 011-82-32-570-1380

Fax: 011-82-32-570-1218

Young Chang America, Inc. (Canadian Division)

P.O. Box 61515

9350 Yonge Street

Richmond Hill, Ontario

Canada L4C 3N0

Tel: (905) 508-0531

Fax: (905) 508 1308

Contents

Young Chang Distributors	iii
--------------------------------	-----

Chapter 1 Introduction

Models	1-1
Notes, Cautions, Warnings	1-1
PC2/PC2X	1-2
PC2/PC2X Rear Panel	1-2
Rear Panel Features.....	1-2
PC2/PC2X Front Panel.....	1-3
Front Panel Features	1-3
PC2R.....	1-6
PC2R Rear Panel.....	1-6
Rear Panel Features.....	1-6
PC2R Front Panel	1-6
Front Panel Features	1-7

Chapter 2 Diagnostics

Diagnostic Tests	2-1
Entering Diagnostics.....	2-2
Diagnostic Test Modes.....	2-2
Run One Test.....	2-2
Run Burn-in.....	2-3
Test Results.....	2-3
Description of Tests.....	2-4
ROM.....	2-4
Read-write.....	2-4
RAM.....	2-4
MABEL	2-4
LISA	2-4
Sound ROM	2-4
ZRAM	2-5
MIDI.....	2-5
LED.....	2-5
PCX-1 ROM.....	2-5
PCX-1 RW.....	2-5
PCX-1 RAM.....	2-5
PCX-1 MABEL	2-6
PCX-1 SROM.....	2-6

Chapter 3 PC2R Disassembly/Assembly

Introduction	3-1
Cables, Connectors.....	3-1
Flat Ribbon Cables.....	3-1
Cable Routing.....	3-1
Required Tools and Materials.....	3-1
Opening the PC2R.....	3-2

Contents

Removing the Top Cover	3-2
Replacing the Top Cover	3-2
Removing the Connector Board	3-3
Replacing the Connector Board	3-4
Removing the Polyphony Expansion Board (PCX-1)	3-5
Replacing the Polyphony Expansion Board (PCX-1)	3-5
Removing the Engine Board	3-6
Replacing the Engine Board	3-6
Front Panel Assembly	3-8
Removing the Front Panel Assembly	3-8
Replacing the Front Panel Assembly	3-8
Removing the Front Panel Faceplate	3-9
Replacing the Front Panel Faceplate	3-9
Front Panel Boards	3-9
Removing the Right Front Panel Board	3-10
Replacing the Right Front Panel Board	3-11
Removing the LCD Board	3-11
Replacing the LCD Board	3-12
Removing the Left Front Panel Board	3-12
Replacing the Left Front Panel Board	3-13
Removing the Headphone/Volume/Power Switch Board	3-14
Replacing the Headphone/Volume/Power Switch Board	3-14

Chapter 4 PC2/PC2X Disassembly/Assembly

Introduction	4-1
Notes, Cautions, Warnings	4-1
Cables, Connectors	4-1
Flat Ribbon Cables	4-1
Cable Routing	4-1
Required Tools and Materials	4-1
Opening the PC2/PC2X	4-2
PC2 Bottom	4-2
PC2X Bottom	4-3
Removing the Top Enclosure	4-4
Replacing the Top Enclosure	4-6
Closing the PC2/PC2X	4-6
Top Enclosure	4-7
Removing the Enclosure Support Walls	4-8
Left Enclosure Support Wall	4-8
Right Enclosure Support Wall	4-8
Replacing the Enclosure Support Walls	4-8
Left Enclosure Support Wall	4-8
Right Enclosure Support Wall	4-8
Removing the Connector Board	4-8
Replacing the Connector Board	4-10
Removing the Front Panel Board	4-10
Replacing the Front Panel Board	4-12
Removing the LCD Board	4-13
Replacing the LCD Board	4-13
Removing the Polyphony Expansion Board (PCX-1)	4-13
Replacing the Polyphony Expansion Board (PCX-1)	4-14

Removing the Slider Board.....	4-14
Replacing the Slider Board	4-15
Removing the Engine Board.....	4-15
Replacing the Engine Board	4-17
Removing the Mod Wheel Assembly.....	4-17
Replacing the Mod Wheel Assembly	4-18
PC2 Keyboard Assembly.....	4-19
Removing the PC2 Keyboard Assembly.....	4-19
Replacing the PC2 Keyboard Assembly	4-20
Disconnecting the PC2 Keyboard	4-21
Connecting the Keyboard	4-21
Removing Keys	4-22
Natural/White Key	4-22
Natural/White Keys.....	4-23
Sharp/Black Keys	4-23
Replacing a Key.....	4-24
Servicing the Keyboard Contact Boards	4-24
Removing the Treble Contact Board	4-24
Replacing the Treble Contact Board	4-24
Removing the Bass Contact Board	4-24
Replacing the Bass Contact Board	4-24
Removing the Keyboard Contact Strips	4-25
Replacing the Keyboard Contact Strips	4-25
PC2X Keyboard Assembly.....	4-26
Removing the PC2X Keyboard Assembly.....	4-26
Replacing the PC2X Keyboard Assembly.....	4-27
Removing Keys	4-27
Natural/White Key	4-28
Natural/White Keys.....	4-28
Sharp/Black Keys	4-29
Replacing a Key.....	4-30
Servicing the Keyboard Contact Boards	4-30
Removing the Treble Contact Board	4-30
Replacing the Treble Contact Board	4-30
Removing the Bass Contact Board	4-30
Replacing the Bass Contact Board	4-31
Removing the Keyboard Contact Strips	4-31
Replacing the Keyboard Contact Strips	4-32
Removing a Key Weight.....	4-32
Replacing a Key Weight	4-33

Chapter 5 Troubleshooting

Introduction	5-1
Cables, Connectors.....	5-1
Flat Ribbon Cables.....	5-1
Cable Routing.....	5-1
Surface-Mount Devices	5-1
Saving User Data.....	5-1
Boot Block.....	5-2
Entering the Boot Block.....	5-2
Resets.....	5-2

Contents

Hard Reset.....	5-2
Soft Reset.....	5-2
Software Updates.....	5-3
File Formats.....	5-3
Installing the Operating System or Setups.....	5-3
Installing a New Boot Block.....	5-4
Installing Sound ROM Options.....	5-4
Replacing the Battery.....	5-5
PC2 Keyboard Models.....	5-5
Accessing the Battery.....	5-5
Removing the Battery.....	5-5
Installing the Battery.....	5-5
PC2R Rack Models.....	5-6
Accessing the Battery.....	5-6
Removing the Battery.....	5-6
Installing the Battery.....	5-6
Scanner Tests.....	5-7
PC2R Rack Models.....	5-7
Front Panel Buttons.....	5-7
Alpha Wheel.....	5-7
Front Panel Knobs.....	5-7
PC2 Keyboard Models.....	5-8
Front Panel Buttons.....	5-8
Alpha Wheel.....	5-8
Front Panel Sliders.....	5-8
Wheels.....	5-9
Keyboard.....	5-9
Switch Pedals 1, 2, and 3.....	5-9
Continuous Pedals 1 and 2.....	5-9
Power Problems.....	5-10
Dead.....	5-10
Audio Problems.....	5-10
No Audio.....	5-10
Front Panel Problems.....	5-11
LCD not lit.....	5-11
Buttons, Sliders or Controllers not working.....	5-11
Keyboard Problems.....	5-12
Dead Keyboard.....	5-12
Dead Note(s).....	5-12
One or More in a Section.....	5-12
Mechanical Noise.....	5-12
PC2R Interconnect Diagram.....	5-13
PC2 Interconnect Diagram.....	5-14

Chapter 6 Parts Lists

Introduction.....	6-1
PC2/PC2X Printed Circuit Boards and Assemblies.....	6-1
PC2R Printed Circuit Boards and Assemblies.....	6-2
PC2R/PC2/PC2X.....	6-3
Engine Board, N012300051.....	6-3
PC2/PC2X.....	6-5

Front Panel Board, N012400052	6-5
Connector Board, N012300061	6-6
LCD Board, N012103800	6-8
Pitch & Mod Wheel Assembly, N012300053	6-8
Slider Board, N012400051	6-9
PC2	6-9
Final Assembly, N012000150	6-9
Keyboard Assembly, N215040311	6-10
PC2X.....	6-11
Final Assembly N012000151	6-11
Keyboard Assembly, N215040413.....	6-12
PC2R.....	6-13
Connector Board, N01230004	6-13
Front Panel Assembly, N012300070	6-14
Left Front Panel Board, N012300080	6-14
Right Front Panel Board, N012300090.....	6-15
Headphone/Volume/Power Switch Board, N012700019	6-15
LCD Board, N012103802	6-15
Final Assembly, N012000153	6-16

Chapter 7 Schematics

Engine Board–Microprocessor (page 1 of 5).....	7-3
Engine Board–Master/Slave Mabels (page 2 of 5)	7-4
Engine Board–Lisa F/X 128Ch Option, Clocks (page 3 of 5).....	7-5
Engine Board–Sound ROM, Uart, Glue, Decoupling (page 4 of 5).....	7-6
Engine Board–Audio Channel, Muting Control (page 5 of 5)	7-7
Front Panel and IBBB Board (keyboard models)–FP Buttons and LEDs (page 1 of 2).....	7-8
Front Panel and IBBB Board (keyboard models)–IBBB Buttons and LEDs (page 2 of 2)	7-9
Connector Board (keyboard models)–Scanner (page 1 of 3).....	7-10
Connector Board (keyboard models)–Digital Interface (page 2 of 3)	7-11
Connector Board (keyboard models)–Power Supply / Audio (page 3 of 3).....	7-12
Slider Board (keyboard models)–Sliders	7-13
Right Front Panel Board (rack models)–FP Buttons and LEDs (page 1 of 2)	7-14
Left Front Panel Board (rack models)–Controllers, FP Buttons and LEDs (page 2 of 2)	7-15
Connector Board (rack models)–Scanner (page 1 of 3).....	7-16
Connector Board (rack models)–Digital Interface (page 2 of 3)	7-17
Connector Board (rack models)–Power Supply / Audio (page 3 of 3).....	7-18
Power/Volume/Headphone Board (rack models)	7-19

Contents

Chapter 1

Introduction

This chapter provides the service technician with a layout of the front and rear panel features, as well as a brief explanation of their functions. For in-depth descriptions of the many features the PC2 Series instruments include, consult the *Musician's Guide*.

This chapter also includes a description of the models available in the PC2 Series and a description of the symbols used throughout this manual.



Note: If possible, all user programs and setups should be saved prior to opening the unit, entering the Boot Block to run diagnostics or to perform a hard reset. For instructions to save all user programs and setups, see *Saving User Data* in Chapter 5, page 5-1.

Models

There are three models in the PC2 series. The available models are listed below.

- PC2, 76-note keyboard
- PC2X, 88-note keyboard
- PC2R, rack-mount

Notes, Cautions, Warnings

Please pay special attention to all Notes, Cautions, and Warnings used throughout this manual as they not only point out specific instructions, but also alert you to differences between the PC2R rack units, the 76-note PC2 keyboard, and the 88-note PC2X keyboard. Certain chapters and sections are solely for the rack or keyboard units. Other chapters combine both the rack and keyboard units.

A brief description of these symbols follows:



Note: Provides additional information, indicates differences between models, and emphasizes specific instructions.



Caution: Instructs you to proceed cautiously so that damage does not occur to the unit or individual components.



Warning: Alerts you so that damage does not occur to yourself, others, or external devices.

PC2/PC2X

PC2/PC2X Rear Panel

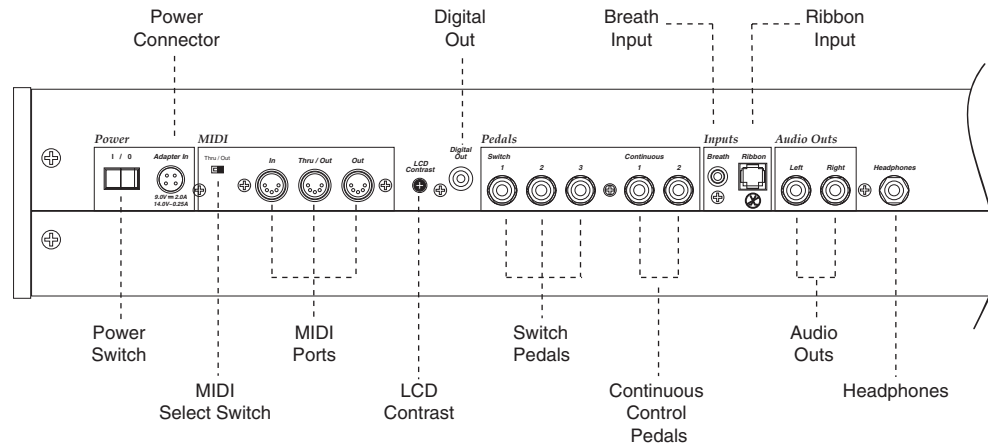

Figure 1-1 PC2 rear panel features

Rear Panel Features

Power Switch—Rocker switch to turn the power on and off.

Power Connector—Keyed four-pin connector to attach the Kurzweil 9VDC power adapter.

MIDI Select Switch—Slide switch to select the operation of the MIDI Thru/Out port. This switch is recessed into the rear panel so that it cannot be accidentally changed.

MIDI Ports—In, Thru/Out, and Out ports to connect the PC2 to other MIDI devices to receive, pass, and send MIDI data.

LCD Contrast—Rotary potentiometer to adjust the LCD for the best visibility.

Digital Out—RCA jack to connect to digital recorders and mixers.

Switch Pedals—Three 1/4" jacks to connect switch pedals that can be assigned to control operations such as sustain, sostenuto, etc. (use 1/4" tip/sleeve).

Continuous Control Pedals—Two 1/4" jacks to connect pedals that can be assigned to control operations such as volume, expression, etc. (use 10K Ω linear taper potentiometer, 1/4" tip/ring/sleeve).

Breath Input—A 3.5mm jack to connect a standard breath controller.

Ribbon Input—Modular jack to connect the Kurzweil Ribbon Controller option.

Audio Outs—Balanced 1/4" left and right audio output jacks to connect to an amplifier, mixer or sound system.

Headphones—Standard 1/4" jack to connect headphones.

PC2/PC2X Front Panel

Figure 1-2 is an illustration of the front panel for the PC2 and the PC2X. Enlargements of sections of this illustration follow, as well as a brief description of the front panel features.

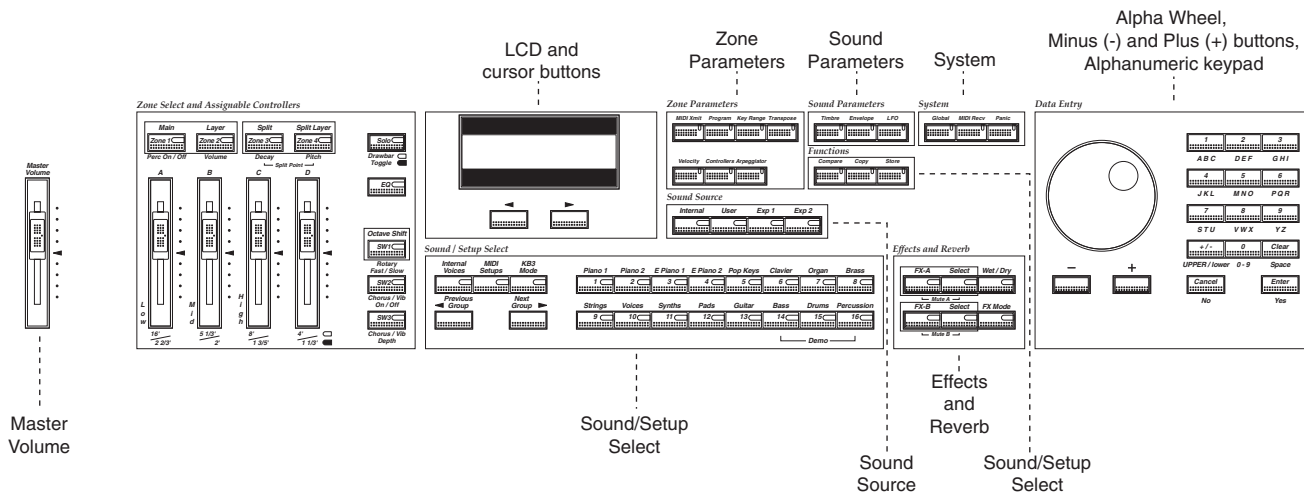

Figure 1-2 PC2/PC2X Front Panel layout

Front Panel Features

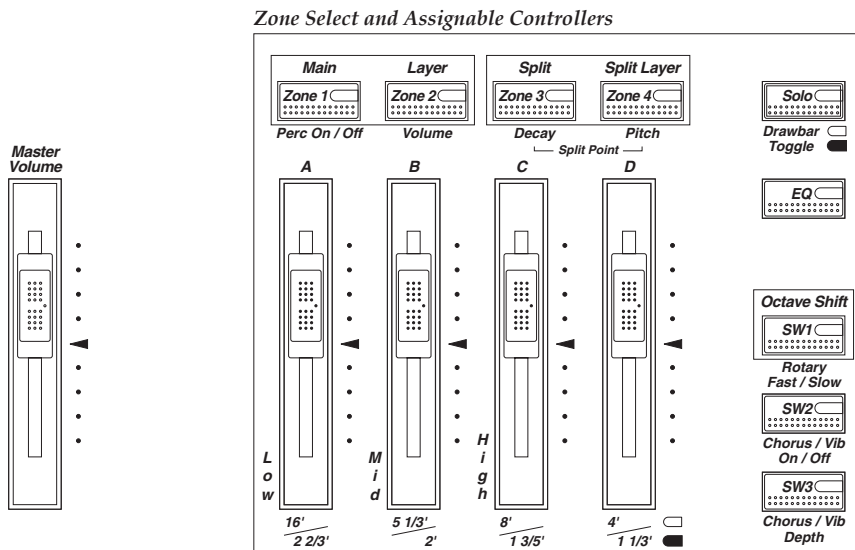

Figure 1-3 Master Volume, Zone Select and Assignable Controllers section

Master Volume—Slidepot to adjust the overall volume.

Zone Select and Assignable Controllers—The operation of the buttons and sliders in this section depends on which of the three performance modes is active. Their labelling is color-coded to identify their function in each of the performance modes. They are labelled as follows: white—Internal Voices mode, blue—MIDI Setups mode, and orange—KB3 mode.

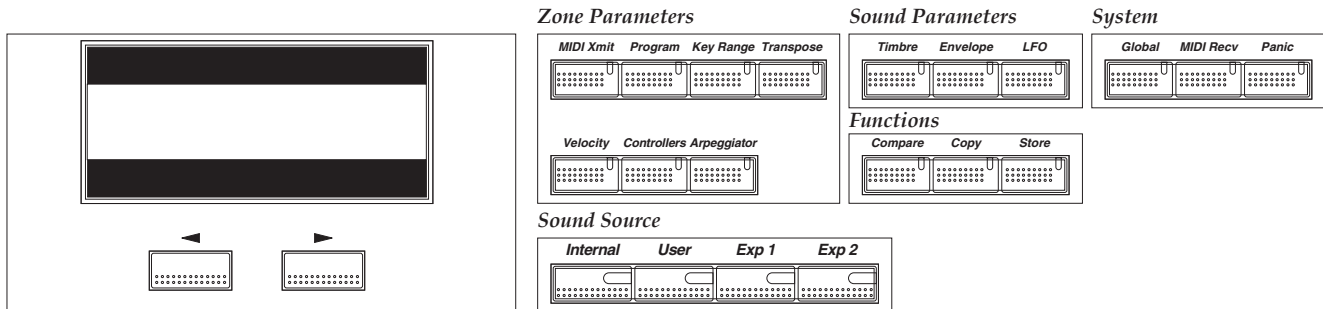

Figure 1-4 PC2 Front Panel, center section

LCD—Forty-character, two-line liquid crystal display.

Cursor buttons—These buttons move the cursor bar in the LCD. Generally, they select bank and program ID parameters and some KB3 settings.

Zone Parameters—Each button in this section represents a menu of available parameters for use while editing setups.

Sound Source—Each button in this section selects a bank of programs or setups for each of the performance modes.

Sound Parameters—Each button in this section represents a menu of available parameters for use while editing programs in the Internal Voices and KB3 modes.

Functions—Use the buttons in this section while editing programs or settings to compare between an original and a modified setup or program, copy sections from one setup to another, and begin the process to store the changes.

System—The three buttons in this section select parameters that affect the entire unit. The **Global** button opens a menu of parameters such as: checking the version of the operating system, available memory, performing a reset, dumping all objects, and running MIDIScope. The **MIDI Receive** button opens a menu to configure individual MIDI channels. The **Panic** button sends an All Notes Off message to the PC2 and the MIDI Out port. On power up, the **Panic** button is also used to enter the boot block to perform diagnostics, operating system updates, etc.

Sound / Setup Select

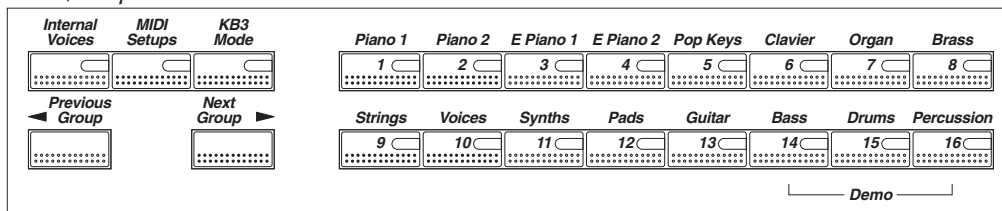

Effects and Reverb

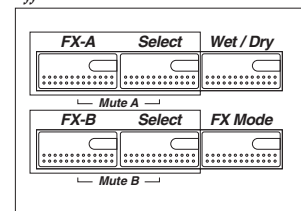

Figure 1-5 Sound/Setup Select and Effects and Reverb sections

Sound/Setup Select—Three groups of buttons are included in this section. Use the buttons in the first group to select one of the three performance modes: **Internal Voices**, **MIDI Setups**, or **KB3 Mode**. The second group, **Previous Group** and **Next Group**, is for use in the Internal Voices and MIDI Setups modes only. Depending on which mode you're in, they select the previous or next group of programs or setups. Use the buttons in the third group, labelled **1–16**, to select a category of Internal Voice programs or MIDI setups. In KB3 Mode, use these buttons to select one of the 16 KB3 programs.

Effects and Reverb—Use the buttons in this section to select from two blocks of effects to apply effects and reverb to programs and setups.

Data Entry

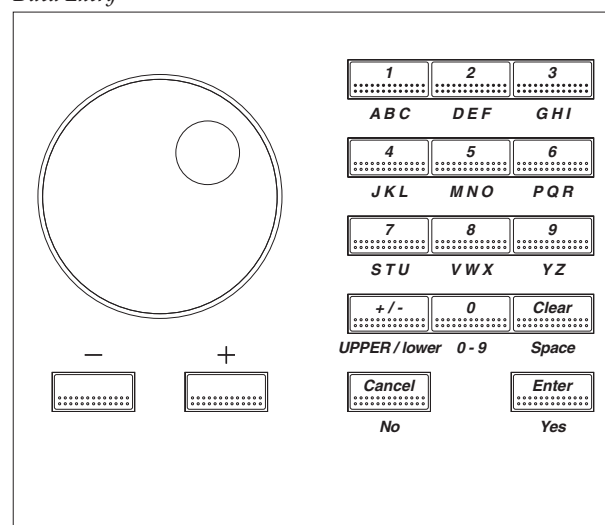

Figure 1-6 Data Entry section

Data Entry—This section contains the Alpha Wheel, **Minus (-)** and **Plus (+)** buttons, and the Alphanumeric keypad. Use the Alpha Wheel or the **Minus (-)** and **Plus (+)** buttons to increase or decrease a value. Use the buttons in the Alphanumeric keypad to enter text, numbers, spaces, etc. This section also includes the **Cancel (No)** and **Enter (Yes)** buttons.

Mod/Pitch Wheel Assembly (not shown)—Use the two wheels to vary modulation and pitch. Also included on the assembly is the **SW4** and **SW5** switches for use in the Internal Voices and MIDI Setups modes.

PC2R

PC2R Rear Panel

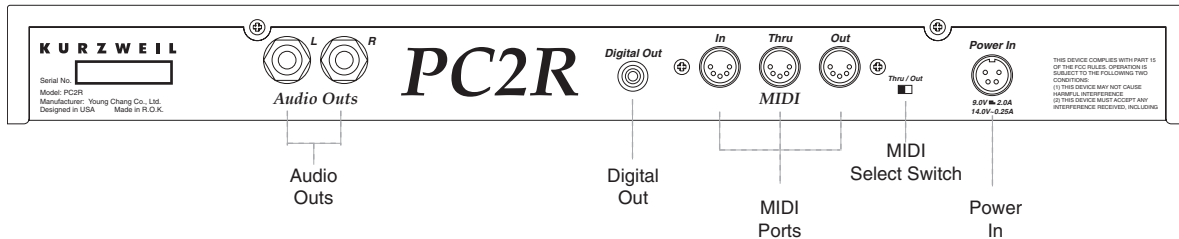

Figure 1-7 PC2R rear panel

Rear Panel Features

Audio Outs—Balanced 1/4" left and right audio output jacks to connect to an amplifier, mixer or sound system.

Digital Out—RCA jack to connect to digital recorders and mixers.

MIDI Ports—In, Thru/Out, and Out ports to connect the PC2 to other MIDI devices to receive, pass, and send MIDI data.

MIDI Select Switch—Slide switch to select the operation of the MIDI Thru/Out port.

Power In—Keyed four-pin connector to attach the Kurzweil 9VDC power adapter.

PC2R Front Panel

Figure 1-8 is an illustration of the front panel for the PC2R. Enlargements of sections of this illustration follow, as well as a brief description of the front panel features.

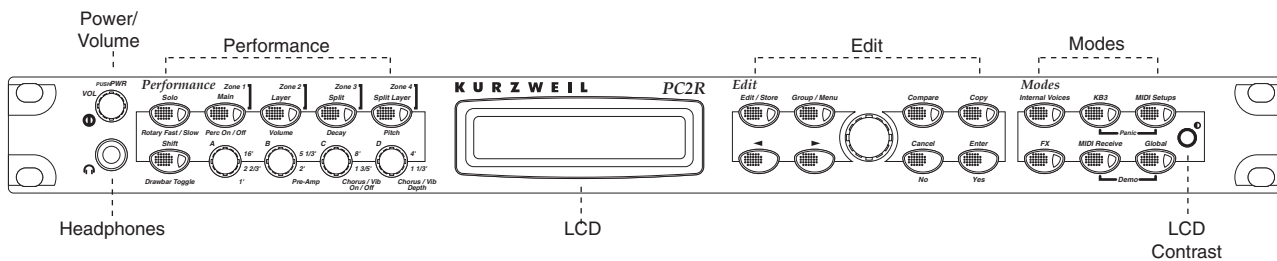

Figure 1-8 PC2R Front Panel

Front Panel Features

Power/Volume—Push to turn the power on/off and turn it to adjust the volume.

Headphones—Standard 1/4" jack to connect headphones.

Performance section—The buttons and knobs in this section are multi-function and their operation depends on which performance mode is active (Internal Voices, KB3, or MIDI Setups). Their labelling is color-coded to identify their operation for each of the performance modes. They are labelled as follows: white—Internal Voices mode, blue—MIDI Setups mode, and orange—KB3 mode.

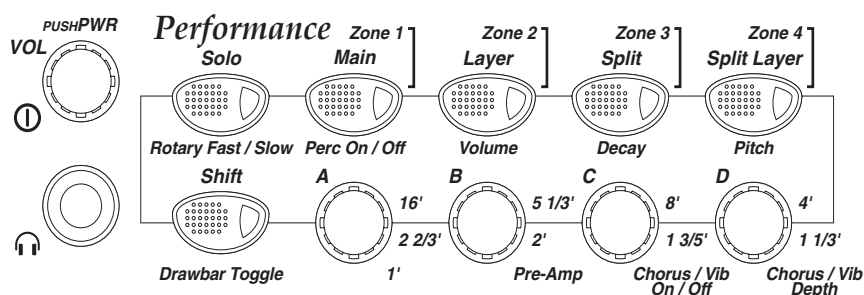

Figure 1-9 Power/Volume, Headphones and Performance section

The top row of buttons are for use in each of the three performance modes. The button LEDs are tri-colored: Red, Green, and Amber. The function of a button depends on which performance mode is active and the LED color. In the Internal Voices mode, use these buttons to enter AutoSplit mode to add layers and splits. In MIDI Setups mode, use these buttons to solo a zone or select a zone for viewing or editing. In KB3 mode, these buttons control the effects for the current KB3 program. Figure 1-9 is an enlargement of the Performance section. An example of the operation of the **Split** button in each performance mode follows:

Internal Voices mode, selecting the **Split** button switches to AutoSplit mode and adds a new sound below a preset split point.

MIDI Setups mode (Zone 3), selecting the **Split** button selects Zone 3.

KB3 mode (Decay), selecting the **Split** button switches between fast and slow decay for the percussion effect.

The bottom row includes the **Shift** button and **Knobs A–D**. The **Shift** button controls the operation of **Knobs A–D**. The **Shift** button LED is also tri-colored (green, amber, and red). The function of **Knobs A–D** depends on which performance mode is active and the LED color. In Internal Voices or MIDI Setups mode, **Knobs A–D** control parameters and settings. In KB3 Mode, **Knobs A–D** control such functions as drawbar lengths, etc.

Edit section—Use the eight buttons and the Alpha Wheel in this section to select programs and setups, and editing functions. Turn the Alpha Wheel to scroll through menus and categories to select a program or parameter. In Internal Voices and KB3 mode, use the **Left** and **Right** cursor buttons to select bank and program ID parameters, as well as some KB3 settings. While editing use these buttons to make selections.

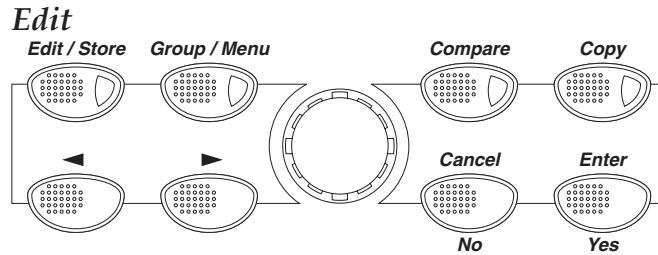

Figure 1-10 Edit section

Select the **Edit/Store** button to enter the edit mode for the current performance mode to edit programs, setups, etc. To save the changes, press the **Edit/Store** button again to enter the save dialog. In a performance mode, press the **Group/Menu** button to select a category of programs or setups. In edit mode, press the **Group/Menu** button to view the menu of parameters.

When editing, the **Compare** button lets you hear the difference between an original and a modified setup or program. The **Copy** button allows you to copy sections from one setup to another. The **Cancel (No)** button exits an edit mode or answers no. In a performance mode, the **Enter (Yes)** button selects a program or setup and answers yes. In an edit mode, press **Enter** to enter menus for editing.

Modes section—Use the buttons in this section to select one of the three performance modes: **Internal Voices**, **KB3**, or **MIDI Setups**. Three special mode buttons (**FX**, **MIDI Receive**, and **Global**) are also included in this section. The special mode buttons perform as follows: press the **FX** button to enter the effect edit mode, press the **MIDI Receive** button to configure individual MIDI channels, and press the **Global** button to select parameters that change the entire PC2R. Many helpful parameters are included in the Global menu such as: the operating system version, available memory, reset, dumping all objects, and MIDIScope.

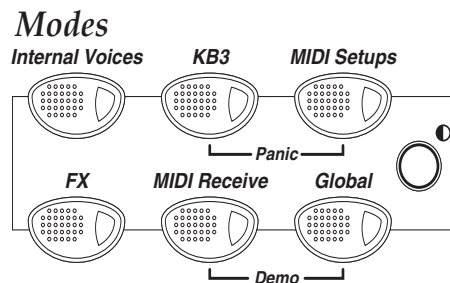

Figure 1-11 Modes section and LCD Contrast

The Modes section also contains buttons to select the **Panic** function and **Demo** mode. These buttons are not individual buttons. They are selected by simultaneously pressing two buttons. To select the Panic function to send an All Notes Off message, simultaneously press the **KB3** and the **MIDI Setups** buttons. To enter the **Demo** mode, simultaneously press the **MIDI Receive** and the **Global** buttons. Flashing LEDs in the Performance section indicate the location of the stored demos.

LCD Contrast—Rotary potentiometer to adjust the LCD for the best visibility.

Chapter 2

Diagnostics

Diagnostic Tests

The following lists the diagnostic tests available for the PC2 Series.

- ROM
- Read-write
- RAM
- MABEL
- LISA
- Sound ROM
- ZRAM
- MIDI
- LED

If a PCX-1 Board is installed, the following tests are also available:

- PCX-1 ROM
- PCX-1 RW
- PCX-1 RAM
- PCX-1 MABEL
- PCX-1 SRAM



Warning: Some diagnostic tests erase user programs and setups. If possible, be sure to save all user programs and setups, before entering diagnostics. For instructions, refer to *Saving User Data* in Chapter 5, page 5-1.

Entering Diagnostics

1. Apply power to the unit. When the **Please wait...** message appears in the LCD, quickly press and release the **Panic** button for PC2 keyboard units or the **Edit** button for PC2R rack units. The LCD should display the following:

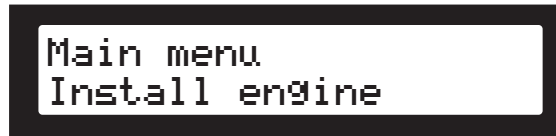

Figure 2-1 LCD example, entering diagnostics

2. Press either the **Left** or **Right** cursor button until **Run diagnostics** appears in the LCD.
3. Press the **Enter** button.
4. The LCD displays the following:

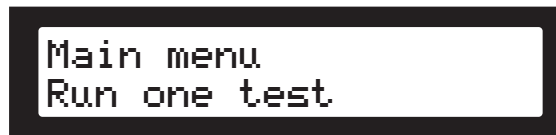

Figure 2-2 LCD example, diagnostic main menu

5. Press **Enter** to select the run one test mode. To select the run burn-in test mode, press either the **Left** or **Right** cursor button then press the **Enter** button to begin the tests.

Diagnostic Test Modes

Run One Test

Run One Test allows you to select an individual test, or to step through and run each available test. To step through the different tests, use the **Left** or **Right** cursor button. Press the **Enter** button to select the test.

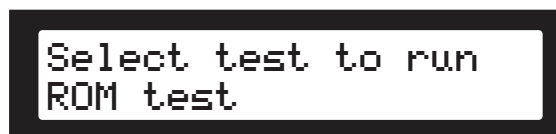

Figure 2-3 LCD example, Run One Test

At the completion of a test, whether pass or fail, press the **Cancel** button to exit the test. Press either the **Left** or **Right** cursor button to advance to the next test or another test in the sequence.

At the completion of a test, press the **Cancel** button to return to the test menu. To exit diagnostics, turn the power off and on to return to normal operation.

Run Burn-in

Burn-in continuously runs the following sequence of tests.

- ROM
- Read-write
- Sound ROM
- ZRAM
- MIDI

If a PCX-1 Board is installed, the sequence of tests is as follows:

- ROM
- Read-write
- MIDI
- PCX-1 ROM
- PCX-1 read

The LCD displays the test results at the completion of each test. To stop the burn-in process and view the test results for each test run, press the **Cancel** button. Use the **Left** or **Right** cursor button to scroll through the results of each test.

To exit Run Burn-in and return to the main menu, press the **Cancel** button. To exit diagnostics, turn the power off and on to return to normal operation.



Note: If a PCX-1 Board is installed, you must cycle the power after running the SROM or PCX-1 SROM tests. If you do not cycle the power, some tests may not run properly.

Test Results

The top line of the LCD displays the test name to the left and test result to the right. Additional information, if any, is displayed on the bottom line of the LCD.

At the completion of an individual test, the LCD displays the test results. An expected result is Pass, Fail, or Not Run.

If a failure occurs, the LCD displays Fail. To the right of Fail, two characters can be displayed in parenthesis. These characters indicate the type of failure. If the test fails a (t) is displayed. If a hardware error occurs an (H) is displayed.

Description of Tests

ROM

This test checks the software data (engine, boot, and setups) stored in FlashROM on the Engine Board.

A failure of this test may indicate a problem with the Flash ROM chip (U5 on the Engine Board), associated circuitry, or the Engine Board.

Read-write

This test is a combination of the RAM, MABEL and LISA tests. The Read-write test writes data to RAM and the MABEL and LISA registers then confirms that the data written can be read back successfully.

A failure of this test indicates a problem with the Engine Board.

RAM

The RAM test writes to the microprocessor RAM space and verifies that the write was successful.

A failure of this test may indicate a problem with the RAM or related circuitry on the Engine Board.

MABEL

This test performs a read-write of the MABEL registers and verifies that the data written can be read back successfully.

A failure of this test may indicate a problem with a MABEL, related circuitry or the Engine Board.

LISA

This test confirms that the Lisa chip (U15) is properly installed and successfully interfacing with the microprocessor.

A failure of this test indicates a problem with Lisa, related circuitry or the Engine Board.

Sound ROM

This test confirms that the Sound ROMs can be read by the MABELs by performing a checksum of the Sound ROMs. The computed checksum is then compared to the stored checksum.

A failure of this test may indicate a problem with a Sound ROM (U19 or U20), or the Engine Board.

ZRAM

This test performs a quick read-write of the internal RAM and verifies that the data was successfully written and retained.

A failure of this test may indicate a problem with the RAM or the Engine Board.

MIDI

The MIDI test performs a loop-back of the serial port by sending a 23-byte pattern over the external MIDI link. This test requires a MIDI loop (a MIDI cable that connects two MIDI jacks). The test will fail if a MIDI cable is not connected between two MIDI jacks. Be sure to run this test with MIDI cables connected as follows:



Note: Be sure to use a known working MIDI cable!

1. Connect a MIDI cable to the MIDI In and MIDI out jacks and run the test.
2. Connect a MIDI cable to the MIDI In and MIDI Out/Thru jack and set the Out/Thru switch on the rear panel to Out. Run the test.

A failure of this test could be caused by failure of the serial port, other MIDI circuitry, or a problem on the Connector Board or the Engine Board.

LED

This test lights all the front panel LEDs. To complete the test and obtain the test result, press the **Cancel** button. When the **Cancel** button is pressed the LEDs shut off and the test result is shown.

A failure of this test may indicate a problem with the Front Panel Board(s), related circuitry or the Connector Board.

PCX-1 ROM

This test checks the software data (engine, boot, and setups) stored in FlashROM on the PCX-1 Board.

Failure of this test may indicate a problem with the Flash ROM chip (U5 on the PCX-1 Board), associated circuitry, or the PCX-1 Board.

PCX-1 RW

This test is a combination of the RAM, MABEL and LISA tests. This test writes data to RAM and the MABEL and LISA registers then confirms that the data written can be read back successfully.

A failure of this test indicates a problem with the PCX-1 Board.

PCX-1 RAM

The PCX-1 RAM test writes to the microprocessor RAM space and verifies that the write was successful.

A failure of this test may indicate a problem with the RAM or related circuitry on the PCX-1 Board.

PCX-1 MABEL

This test performs a read-write of the MABEL registers and verifies that the data written can be read back successfully.

A failure of this test may indicate a problem with a MABEL, associated circuitry or the PCX-1 Board.

PCX-1 SROM

The PCX-1 SROM test verifies that the PCX-1 MABELs can read the Sound ROMs by performing a checksum of the Sound ROMs. The computed checksum is then compared to the stored checksum.

A failure of this test indicates a problem with a Sound ROM (U15 or U16) or the PCX-1 Board.

Chapter 3

PC2R Disassembly/Assembly

Introduction

This chapter contains all the procedures for the disassembly and reassembly for the PC2R—as well as instruments with factory-installed or after-market options.



Warning: If possible, save all user programs and setups before disassembly. For instructions, refer to *Saving User Data* in Chapter 5, page 5-1.

Cables, Connectors

Flat Ribbon Cables

All flat ribbon cables with connectors are keyed, and therefore cannot be reversed. Most flat ribbon cables have locking cable clips. Be sure to reapply the clips when connecting cables. Flat ribbon cables that connect to picoflex connectors do not have locking cable clips.

Some flat ribbon cables have exposed wires that insert directly into a wire trap connector. When disconnecting and connecting these cables, you must look for the marking on the edge of the cable denoting Pin 1 and be sure that you match it correctly with Pin 1 on the board.

Cable Routing

In some cases, tape secures cable connections or fastens cables to the bottom enclosure. Always peel back the tape from one side when disconnecting cables so that the tape remains properly positioned.

Required Tools and Materials

- No. 1 Phillips head screwdriver
- No. 2 Phillips head screwdriver
- Small flat screwdriver
- Needle-nose pliers

Opening the PC2R

Removing the Top Cover

Before you begin disassembly, please be sure that the power is off, and that the AC power adapter and all other cables are disconnected.

The top cover is secured to the PC2R with seven screws: three on the top, one on each side, and two on the rear. See Figure 3-1.

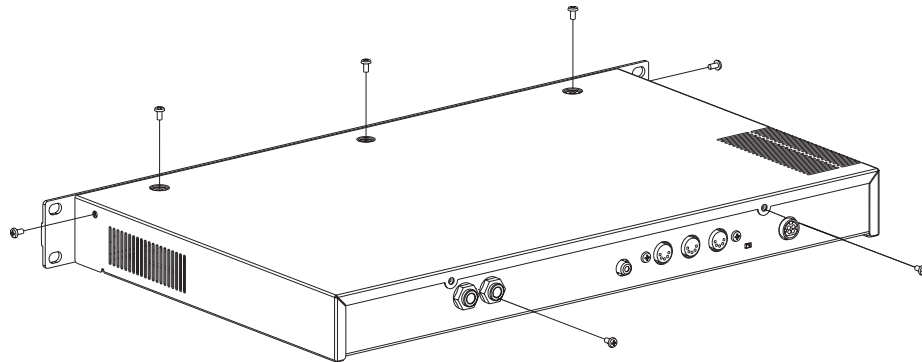

Figure 3-1 PC2R top cover

1. Remove the seven screws that secure the top cover.

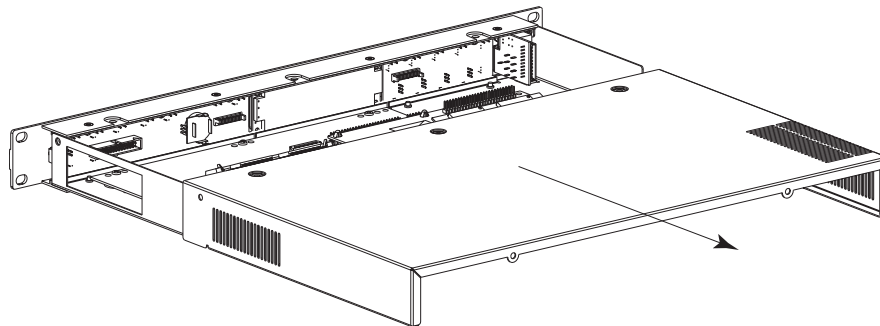

Figure 3-2 Removing the top cover

2. Refer to Figure 3-2. Slide the top cover back from the Front Panel Assembly to release the top cover from the bottom enclosure, and place the top cover safely aside to avoid damage.

Replacing the Top Cover

1. Place the top cover in position and slide it toward the Front Panel Assembly.
2. Install the seven screws that secure the top cover. See Figure 3-1.

Removing the Connector Board

1. Following Steps 2– 5, disconnect the cables listed in Table 3-1.

Ref.	Name	Cable Type	Destination
J301	PC2 Power	stranded wire	Engine Board
J302	PC2R Audio In	flat ribbon	Engine Board
J303	MIDI/CPU	flat ribbon	Engine Board
J304	Front Panel	flat ribbon	Right Front Panel Board
J322	FP/Vol/Pwr/Hp	stranded wire	Headphone/Vol/Pwr Sw Board

Table 3-1 Connector Board cables

2. Disconnect the stranded wire cable from J301 on the Connector Board.
3. Remove the cable locking clip and disconnect the flat ribbon cable from J304. Be sure to set the cable locking clip safely aside so that you can install it when you reconnect the cable.
4. Disconnect the stranded wire cable from J322.
5. The flat ribbon cables connected to J302 and J303 use wire trap connectors. The shielding has been removed from these cables to expose the wires. The wires are directly inserted into these connectors.

Lift up the sides of each connector. This unlocks the trap to free the cable wires. Gently pull each cable up out of the connector. Note the marking (red or black) on each cable that indicates the connection to Pin 1; you'll need to reconnect the marked edge of the cable to Pin 1 when you replace the Connector Board.

6. Remove the two screws that secure the MIDI jacks to the rear panel.
7. Remove the two nuts that secure the 1/4" audio out jacks to the rear panel.
8. Remove the three screws that secure the Connector Board to the bottom enclosure.



Caution: VR1 on the Connector Board is attached to the heat sink. When you remove the Connector Board and heat sink, be sure to keep the board and heat sink stable so that you do not damage VR1 or its connection.

9. Remove the four screws that secure the heat sink to the bottom enclosure.
10. Slide the Connector Board and heat sink away from the rear panel and toward the Front Panel Assembly. This will free the jacks and MIDI switch from their positions on the rear panel.
11. Tilt up the rear panel edge of the Connector Board and heat sink. Carefully lift the board and heat sink out of the PC2R, and place them on a flat protected surface.

Replacing the Connector Board

1. Tilt down the inner edge (closest to the Front Panel Assembly) of the Connector Board and heat sink, and place it flat on to the bottom enclosure.
2. Slide the Connector Board and heat sink toward the rear panel so that the jacks and MIDI switch are positioned through their openings in the rear panel.
3. Install the four screws that secure the heat sink to the bottom enclosure.
4. Install the three screws that secure the Connector Board to the bottom enclosure.
5. Install the two screws that secure the MIDI jacks to the rear panel.
6. Install the two nuts that secure the 1/4" audio out jacks to the rear panel.
7. Connect the wire trap flat ribbon cables in the following order.



Caution: Be sure to look for the marking on the edge of the cable denoting Pin 1 and that you match it correctly with Pin 1 on the board. Make certain that the wires are straight prior to inserting them into the connector and that each wire is correctly inserted into its respective position.



Note: Be sure the sides of the connector are lifted. Insert the flat ribbon cables into the wire trap connectors and push down the sides of each connector to lock the cable into the connector. Gently pull each cable to verify that it is locked into its connector.

Insert the five-wire flat ribbon cable from the Engine Board into the wire trap connector at J302 on the Connector Board.

Insert the ten-wire flat ribbon cable from the Engine Board into the wire trap connector at J303 on the Connector Board.

8. Connect the stranded wire cable from the Headphone/Volume/Power Switch Board to J322.
9. Connect the flat ribbon cable from the Right Front Panel Board to J304. Be sure to install the cable locking clip.
10. Connect the stranded wire cable from the Engine Board to J301.

Removing the Polyphony Expansion Board (PCX-1)

The Polyphony Expansion Board is mounted onto the Engine Board and held in place with four nylon PC board standoffs and a 24-pin female connector on the underside of the board. It is also secured to the bottom enclosure with two screws.

1. Remove the two screws that secure the PCX-1 Board to the bottom enclosure.
2. Squeeze the top of one of the four nylon PC board standoffs, and lift the corner of the board until it clears that standoff. Repeat for the other three standoffs.
3. When the board is free of the standoffs, lift the board straight up to disconnect the 24-pin connector from the Engine Board.

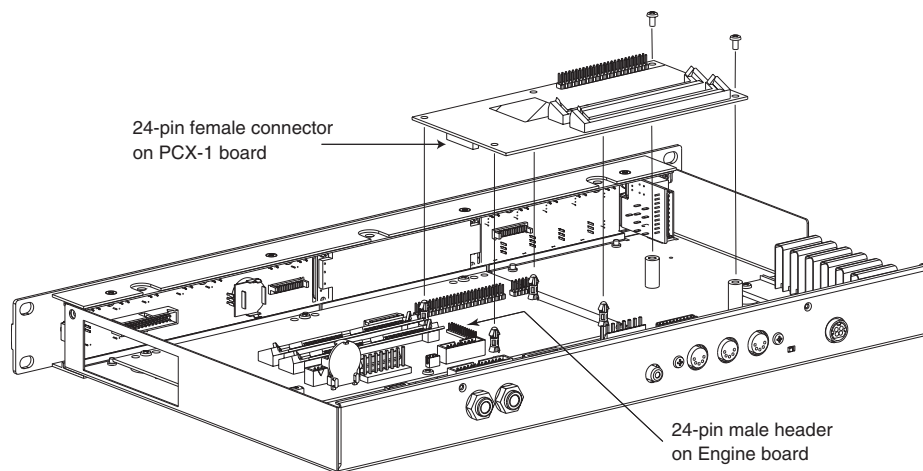

Figure 3-3 Removing the Polyphony Expansion Board (PCX-1)

Replacing the Polyphony Expansion Board (PCX-1)

There are two cables routed underneath the PCX-1 Board: a flat ribbon cable from the LCD to the Engine Board, and a stranded wire cable from the Headphone/Volume/Power Switch Board to the Connector Board. Before you replace the PCX-1 Board, be certain that these cables are properly positioned.

1. Place the PCX-1 Board over the four standoffs. This should properly position the 24-pin connector over the 24-pin header on the Engine Board.
2. Press the PCX-1 Board down, securing the 24-pin connector, and snapping the board onto the standoffs.



Note: If you are installing a new PCX-1 Board, check the old board for Sound ROM options. If the unit has Sound ROM options, be sure to install them on the new board.

3. Install the two screws that secure the PCX-1 Board to the bottom enclosure.

Removing the Engine Board

1. If the PC2R you are servicing has a PCX-1 Board installed, remove it following the procedure described on page 3-5.
2. Following Steps 3–6, disconnect the cables listed in Table 3-2.

Ref.	Name	Cable Type	Destination
J304	Front Panel	flat ribbon	Right Front Panel to Connector
J402	PC2 Power	stranded wire	Connector Board
J403	MIDI/CPU	flat ribbon	Connector Board
J405	Backlight	stranded wire	LCD Board
J406	LCD	flat ribbon	LCD Board
J412	PC2 Audio Out	flat ribbon	Connector Board

Table 3-2 Engine Board cables

3. Remove the cable locking clip and disconnect the flat ribbon cable from J304 on the Connector Board. Be sure to set the cable locking clip safely aside so that you can install it when you reconnect the cable.
4. The flat ribbon cables connected to J403 and J412 use wire trap connectors. The shielding has been removed from these cables to expose the wires. The wires are directly inserted into these connectors.

Lift up the sides of each connector. This unlocks the trap to free the cable wires. Gently pull each cable up out of the connector. Note the marking (red or black) on each cable that indicates the connection to Pin 1; you'll need to reconnect the marked edge of the cable to Pin 1 when you replace the Engine Board.

5. Remove the cable locking clip and disconnect the flat ribbon cable from location J406 on the Engine Board. Be sure to set the cable locking clip safely aside so that you can install it when you reconnect the cable.
6. Disconnect the stranded wire cables from locations J402 and J405 on the Engine Board.
7. Remove the five screws that secure the Engine Board to the bottom enclosure and remove the Engine Board.

Replacing the Engine Board

1. Place the Engine Board on the bottom enclosure.
2. Install the five screws that secure the Engine Board to the bottom enclosure.
3. Connect the stranded wire cable from the Connector Board to J402.
4. Connect the stranded wire cable from the LCD Board to J405.
5. Connect the flat ribbon cable from the LCD Board to J406. Be sure to install the cable locking clip.
6. Connect the wire trap flat ribbon cables in the following order.



Caution: Be sure to look for the marking on the edge of the cable denoting Pin 1 and that you match it correctly with Pin 1 on the board. Make certain that the wires are straight prior to inserting them into the connector and that each wire is correctly inserted into its respective position.



Note: Be sure the sides of the connector are lifted. Insert the flat ribbon cables into the wire trap connectors and push down the sides of each connector to lock the cable into the connector. Gently pull each cable to verify that it is locked into its connector.

Insert the five-wire flat ribbon cable from the Connector Board into the wire trap connector at J412 on the Engine Board.

Insert the ten-wire flat ribbon cable from the Connector Board into the wire trap connector at J403 on the Engine Board.

7. Connect the flat ribbon cable from the Right Front Panel Board to J304 on the Connector Board. Be sure to install the cable locking clip.
8. If you removed a PCX-1 Board, install it following the procedure on page 3-5.

Front Panel Assembly

The Front Panel Assembly consists of the front panel faceplate, a mounting bracket for the front panel boards, and four printed circuit boards. The boards mounted on the Front Panel Assembly are the Right Front Panel, LCD, Left Front Panel, and Headphone/Volume/Power Switch.

Removing the Front Panel Assembly

Refer to Figure 3-4. The bottom edge of the Front Panel Assembly and front edge of the bottom enclosure connect to form a lip.

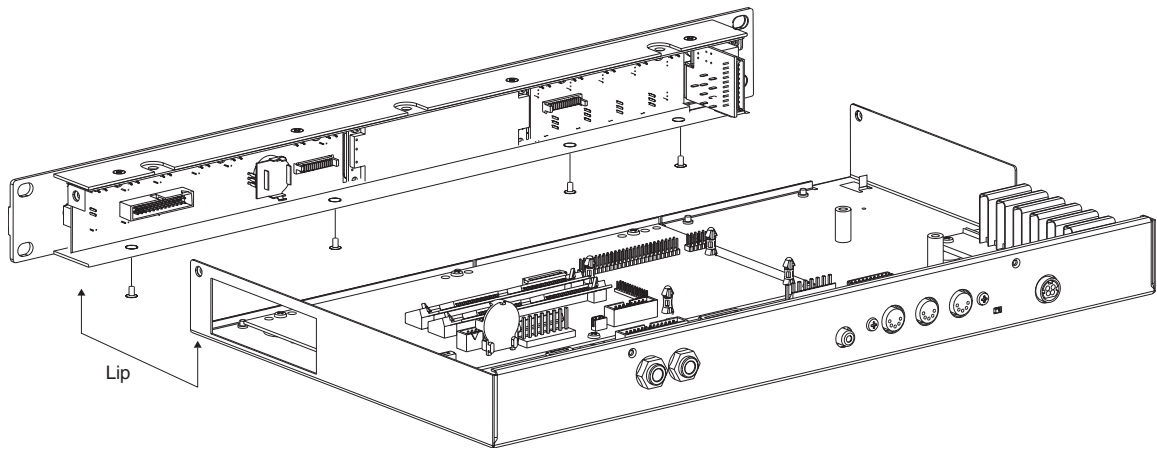

Figure 3-4 Front Panel Assembly and bottom enclosure

1. Tilt up the front edge of the PC2R.
2. Using a #1 screwdriver, remove the four screws that secure the Front Panel Assembly to the bottom enclosure.



Note: Before continuing, be sure that you have a soft surface to rest the Front Panel Assembly on so that the front panel switches, jacks, and rotary potentiometers are not damaged.

3. Slide the Front Panel Assembly forward and away from the bottom enclosure.



Caution: There are four cables connected to the Front Panel Assembly. You do not need to disconnect these cables.

Replacing the Front Panel Assembly

1. Position the Front Panel Assembly so that its bottom edge is under the front edge of the bottom enclosure.
2. Tilt up the front edge of the PC2R and install the four black flat head machine screws.

Removing the Front Panel Faceplate



Note: If the service you are performing only requires that you have access to the front panel boards for component testing, component replacement or installing a replacement board, it is not necessary to remove the front panel faceplate. Refer to the procedure for the front panel board you need to remove and follow the steps described.

1. Follow the procedure to remove the Front Panel Assembly.
2. Refer to Figure 3-5 on page 3-10. Four flat head machine screws secure the front panel faceplate to the Front Panel Assembly. These screws are located along the top of the Front Panel Assembly.

Using a #1 screwdriver, remove the four screws.

3. Place the front panel faceplate safely aside to avoid accidental damage.

Replacing the Front Panel Faceplate

1. Position the front panel faceplate onto the Front Panel Assembly.



Note: Verify that the rotary potentiometers, jacks, and switch button caps are correctly positioned through their openings in the front panel faceplate. Turn the rotary potentiometers to be sure that they move freely; and push the switch button caps to be sure that their corresponding switches click.

2. Install the four flat head machine screws that secure the front panel faceplate to the Front Panel Assembly.

Front Panel Boards

The front panel boards are secured to a mounting bracket. This bracket is secured to the front panel faceplate.

If the service you are performing only requires that you have access to the front panel boards for component testing, component replacement or installing a replacement board, it is not necessary to remove the front panel faceplate or remove the boards from the mounting bracket.

Figure 3-5 shows the position of the boards on the Front Panel Assembly and the placement of the front panel faceplate screws located above the boards. Refer to the procedure for the front panel board you need to remove and follow the steps described.

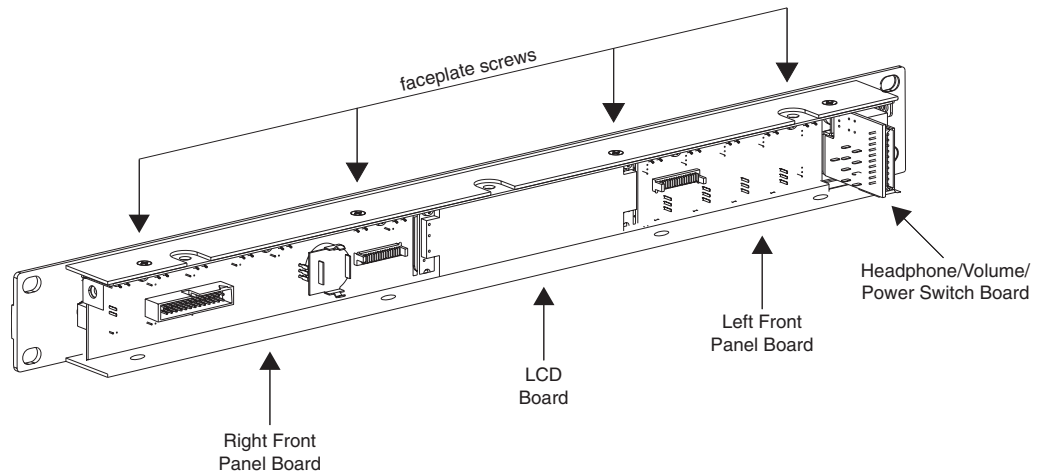

Figure 3-5 Front panel faceplate screw locations

Removing the Right Front Panel Board

1. Remove the Front Panel Assembly, as described on page 3-8. It is not necessary to disconnect all the cables that connect the Front Panel Assembly boards to boards located on the bottom enclosure.
2. Remove the cable locking clip and disconnect the flat ribbon cable from J601 on the Right Front Panel Board.
3. Disconnect the flat ribbon cable from J602. This cable uses a picoflex molex connector. To disconnect it, grip the connector and pull it out straight.



Caution: Do not wiggle the connector back and forth. Doing so, could cause damage to the header.



Note: Be aware of the marking (red or black) on the cable that indicates the connection to Pin 1; you'll need to reconnect the marked edge of the cable to Pin 1 when you replace the board.

4. It is not necessary to remove the front panel faceplate to remove the Right Front Panel Board. Two of the screws that secure the front panel faceplate to the Front Panel Assembly are located above the Right Front Panel Board. Refer to Figure 3-5 and remove the two screws.
5. Remove the three screws that secure the Right Front Panel Board to the mounting bracket, and remove the Right Front Panel Board.

Replacing the Right Front Panel Board

1. Place the Right Front Panel Board in position on the mounting bracket and line up the screw holes.



Note: Verify that the rotary potentiometers and switch button caps are correctly positioned through their openings in the front panel faceplate. Turn the rotary potentiometers to be sure that they move freely; and push the switch button caps to be sure that their corresponding switches click.

2. Install the three screws that secure the board to the mounting bracket.
3. Install the two screws that secure the front panel faceplate.
4. Connect the flat ribbon cable from the Connector Board to Right Front Panel Board, location J601. Be sure to install the cable locking clip.
5. Connect the flat ribbon cable from the Left Front Panel Board to the Right Front Panel Board, location J602.



Caution: The side walls of the picoflex header are different. The Pin 1 side is slightly wider than the other side; and the corresponding sides of the connector incorporate the differences. When you connect the cable, be sure to orient the marking (red or black) on the cable that indicates the connection to Pin 1 on the board to prevent damage to the header or a failure caused by an improper connection.

6. Follow the procedure on page 3-8 to install the Front Panel Assembly.

Removing the LCD Board

1. Remove the Front Panel Assembly, as described on page 3-8. It is not necessary to disconnect all the cables that connect the Front Panel Assembly boards to boards located on the bottom enclosure.
2. Disconnect the stranded wire cable soldered to the LCD Board from location J405 on the Engine Board.
3. Remove the locking cable clip and disconnect the flat ribbon cable soldered to the LCD Board from location J406 on the Engine Board. If the unit you are servicing has a PCX-1 Board installed, this cable is routed underneath the PCX-1 Board.

After you disconnect the cable, carefully slide it so that it is positioned close to the left edge of the PCX-1 Board (left edge as viewed standing at the front panel). Gently pull the cable toward the Front Panel Assembly to completely free it from underneath the PCX-1 Board.

4. It is not necessary to remove the front panel faceplate to remove the LCD Board. One screw that secures the faceplate to the Front Panel Assembly is located above the LCD Board. Refer to Figure 3-5 and remove the screw.
5. Remove the two screws that secure the LCD Board to the mounting bracket, and remove the LCD.

Replacing the LCD Board

1. Place the LCD Board in position over the mounting standoffs on the mounting bracket.
2. Install the two screws that secure the LCD Board to the mounting bracket.
3. Install the screw that secures the front panel faceplate to the Front Panel Assembly.
4. Connect the stranded wire cable from the LCD Board to location J405 on the Engine Board.
5. If the unit you are servicing has a PCX-1 Board installed, route the flat ribbon cable beneath the board and connect it to location J406 on the Engine Board. Be sure to install the cable locking clip.
6. Follow the procedure on page 3-8 to install the Front Panel Assembly.

Removing the Left Front Panel Board

1. Remove the Front Panel Assembly, as described on page 3-8. It is not necessary to disconnect all the cables that connect the Front Panel Assembly boards to boards located on the bottom enclosure.
2. Disconnect the flat ribbon cable from J603. This cable uses a picoflex molex connector. To disconnect it, grip the connector and pull it out straight.



Caution: Do not wiggle the connector back and forth. Doing so, could cause damage to the header.



Note: Be aware of the marking (red or black) on the cable that indicates the connection to Pin 1; you'll need to reconnect the marked edge of the cable to Pin 1 when you replace the board.

3. It is not necessary to remove the front panel faceplate to remove the Left Front Panel Board. One screw that secures the front panel faceplate to the Front Panel Assembly is located above the Left Front Panel Board. Refer to Figure 3-5 and remove the screw.
4. Remove the two screws that secure the Left Front Panel Board to the mounting bracket.
5. Refer to Figure 3-6. This illustration shows the location of a soldered connection between the Left Front Panel and Headphone/Volume/Power Switch Boards. To remove the board, desolder this connection from the Left Front Panel Board.



Note: This illustration shows the Headphone/Volume/Power Switch Board lying flat to indicate the connection between it and the Left Front Panel Board. In its normal position, it is perpendicular to the Left Front Panel Board.

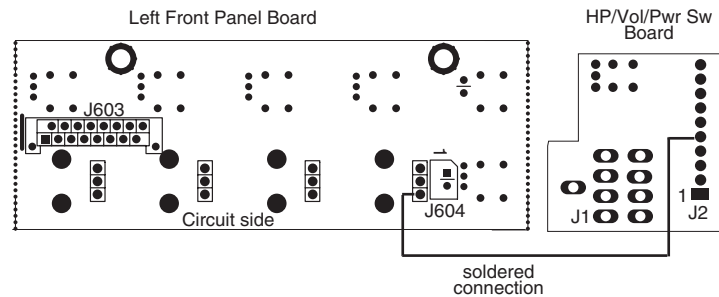

Figure 3-6 Left Front Panel and Headphone/Volume/Power Switch Board connection

6. Remove the Left Front Panel Board.

Replacing the Left Front Panel Board

1. Place the Left Front Panel Board in position on the mounting bracket and line up the screw holes.
2. Install the two screws that secure the board to the mounting bracket.



Note: Verify that the rotary potentiometers and switch button caps are correctly positioned through their openings in the front panel faceplate. Turn the rotary potentiometers to be sure that they move freely; and push the switch button caps to be sure that their corresponding switches click.

3. Install the screw that secures the front panel faceplate.
4. Connect the flat ribbon cable from the Right Front Panel Board to the Left Front Panel Board, location J603.



Caution: The side walls of the picoflex header are different. The Pin 1 side is slightly wider than the other side; and the corresponding sides of the connector incorporate the differences. When you connect the cable, be sure to orient the marking (red or black) on the cable that indicates the connection to Pin 1 on the board to prevent damage to the header, connector or a failure caused by an improper connection.

5. Refer to Figure 3-6. Solder the wire connection from the Headphone/Volume/Power Switch Board to the location indicated on the Left Front Panel Board.
6. Follow the procedure on page 3-8 to install the Front Panel Assembly.

Removing the Headphone/Volume/Power Switch Board

1. Remove the Front Panel Assembly, as described on page 3-8. It is not necessary to disconnect all the cables that connect the Front Panel Assembly boards to boards located on the bottom enclosure.
2. Follow the procedure on page 3-9 to remove the front panel faceplate.
3. Disconnect the stranded wire cable that connects the Headphone/Volume/Power Switch Board to the Connector Board.
4. Remove the nut and flat washer that secure the headphone jack to the front panel mounting plate.
5. Remove the volume knob.
6. Remove the nut and flat washer that secure the volume/power switch to the front panel mounting plate.
7. Refer to Figure 3-6. This illustration shows the location of a soldered connection between the Left Front Panel and Headphone/Volume/Power Switch Boards. To remove the board, desolder this connection from the Headphone/Volume/Power Switch Board.



Note: This illustration shows the Headphone/Volume/Power Switch Board lying flat to indicate the connection between it and the Left Front Panel Board. In its normal position, it is perpendicular to the Left Front Panel Board.

8. Remove the Headphone/Volume/Power Switch Board.

Replacing the Headphone/Volume/Power Switch Board

1. Position the Headphone/Volume/Power Switch Board on the mounting bracket.
2. Install the nut and washer that secure the headphone jack to the mounting bracket.
3. Install the nut and washer that secure the volume/power switch to the mounting bracket.
4. Install the volume knob.
5. Refer to Figure 3-6. Solder the wire connection from the Left Front Panel Board to Pin 5 of J2 on the Headphone/Volume/Power Switch Board.
6. Follow the procedure on page 3-9 to install the front panel faceplate.



Note: Be sure that the Volume/Power Switch moves freely.

7. Follow the procedure on page 3-8 to install the Front Panel Assembly.

Chapter 4

PC2/PC2X Disassembly/Assembly

Introduction

This chapter contains all the procedures for the disassembly and reassembly of both the 76-note PC2 and the 88-note PC2X—as well as instruments with factory-installed or after-market options. There are five main sections: *Opening the PC2/PC2X, Top Enclosure, PC2 Keyboard Assembly, and PC2X Keyboard Assembly.*



Warning: If possible, save all user programs and setups before disassembly. For instructions, refer to *Saving User Data* in Chapter 5, page 5-1.

Notes, Cautions, Warnings

Please pay special attention to all Notes, Cautions, and Warnings as they not only point out specific instructions, but also alert you to differences between the 76-note PC2 keyboard and the 88-note PC2X keyboard.

Cables, Connectors

Flat Ribbon Cables

All flat ribbon cables with connectors are keyed, and therefore cannot be reversed. Most flat ribbon cables have locking cable clips. Be sure to reapply the clips when connecting cables.

Some flat ribbon cables have exposed wires that insert directly into a wire trap connector. When disconnecting and connecting these cables, you must look for the marking on the edge of the cable denoting Pin 1 and be sure that you match it correctly with Pin 1 on the board.

Cable Routing

In some cases, tape secures cable connections or fastens cables to the bottom enclosure. Always peel back the tape from one side when disconnecting cables so that the tape remains properly positioned.

Required Tools and Materials

- No. 1 Phillips head screwdriver
- No. 2 Phillips head screwdriver
- Small flat screwdriver
- Dowel (3mm diameter)
- Needle-nose pliers
- Small blunt-end tool (Q-Tip, toothpick, etc.)
- Foam blocks

Opening the PC2/PC2X

PC2 Bottom

Refer to Figure 4-1. Arrows indicate the locations of the enclosure support wall, endcap and rear panel screws.

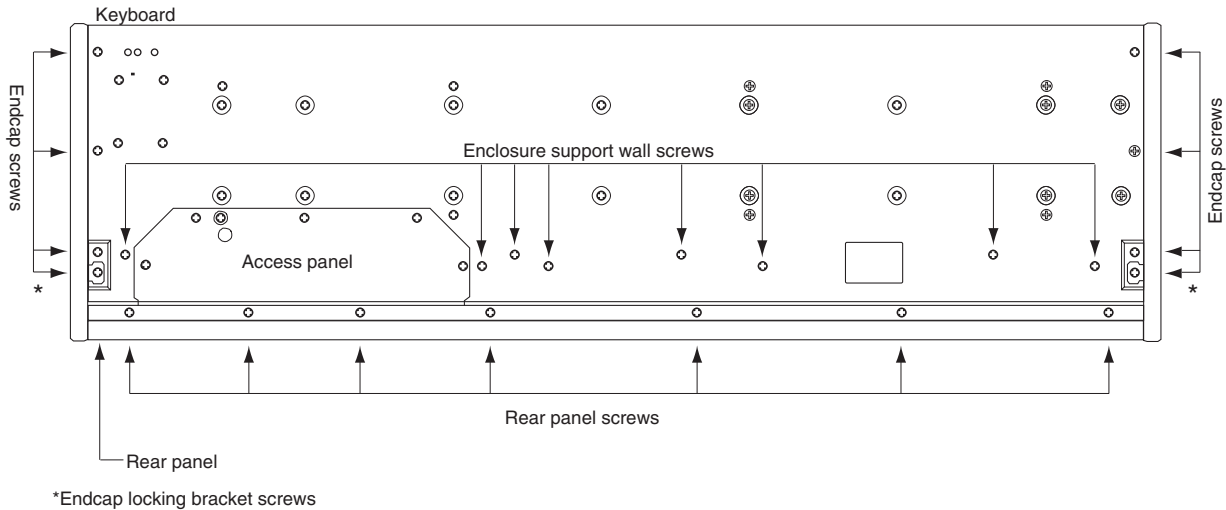

Figure 4-1 PC2 bottom enclosure



Caution: Do not remove the endcap or rear panel screws at this point of the procedure.

1. Tilt the PC2 up and remove the eight enclosure support wall screws.
2. Place the unit flat on your work surface.
3. Move the unit so that the rear panel portion of the unit hangs over the edge of your work surface. This gives you access to the seven screws that secure the rear panel portion of the top enclosure to the bottom enclosure. Remove the seven screws.



Note: Two of the rear panel screws also secure the rear panel portion of the access panel. It is not necessary to remove the five remaining access panel screws.

4. Slide the unit back onto the work surface.

PC2X Bottom

Refer to Figure 4-2. Arrows indicate the locations of the enclosure support wall, endcap and rear panel screws.

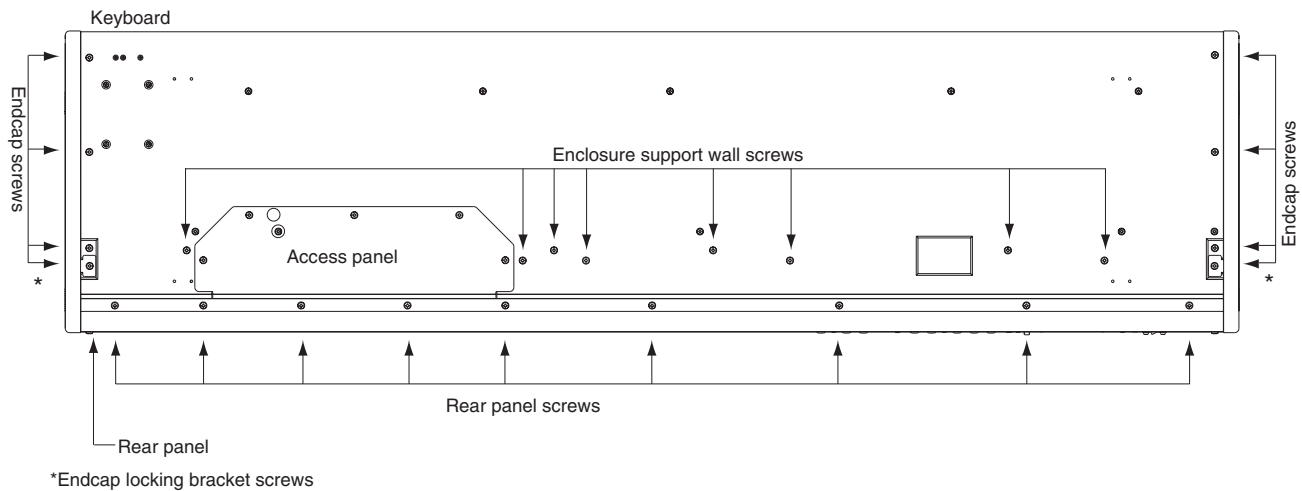

Figure 4-2 PC2X bottom enclosure



Caution: Do not remove the endcap or rear panel screws at this point of the procedure.

1. Tilt the PC2X up and remove the eight enclosure support wall screws.
2. Place the unit flat on your work surface.
3. Move the unit so that the rear panel portion of the unit hangs over the edge of your work surface. This gives you access to the nine screws that secure the rear panel portion of the top enclosure to the bottom enclosure. Remove the nine screws.



Note: Two of the rear panel screws also secure the rear panel edge of the access panel. It is not necessary to remove the five remaining access panel screws.

4. Slide the unit back onto the work surface.

Removing the Top Enclosure

1. Depending on the unit you are servicing, follow the procedures described on page 4-2 for the PC2 bottom or page 4-3 for the PC2X bottom.
2. Refer to Figure 4-3.



Note: Figure 4-3 is an illustration of the PC2 rear panel. An illustration of the PC2X has not been included because the difference between the two is minimal. The quantity and position of the endcap screws is identical.

3. Remove the four screws that secure the endcaps to the rear panel.

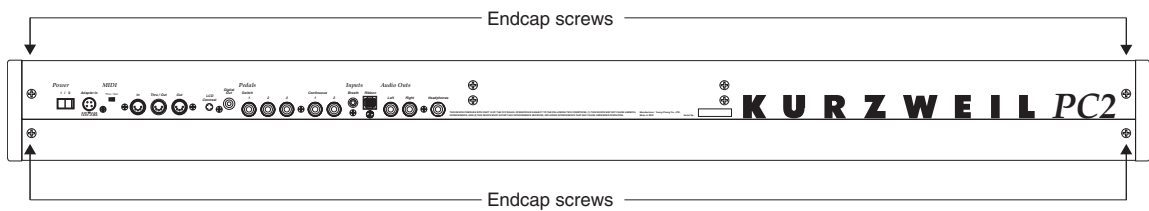

Figure 4-3 PC2 rear panel



Caution: The following steps describe removing the left and right endcaps. To avoid damage to the endcaps, be sure to hold onto each endcap when removing the screws. When the endcap screws are removed, the endcap is free of the unit.

4. Refer to Figure 4-1 for the PC2 or Figure 4-2 for the PC2X. Move the unit so that one end hangs over the edge of your work surface. Remove the four endcap screws from the bottom enclosure. One of these screws secures the endcap locking bracket. When you remove the endcap locking bracket screw, the bracket remains loosely in the endcap assembly. Set the endcap safely aside. Repeat for the other endcap.
5. Refer to Figure 4-4. The bottom edge of the rear panel and back edge of the bottom enclosure connect to form a lip. The rear panel screws secure the lip.



Note: Figure 4-4 is an illustration of the PC2. An illustration of the PC2X has not been included because the difference between the two is minimal. The only difference is the spacing and quantity of the rear panel screws. If you are servicing a PC2, there are seven screws securing the rear panel portion of the top enclosure to the bottom enclosure. If you are servicing a PC2X, there are nine screws.

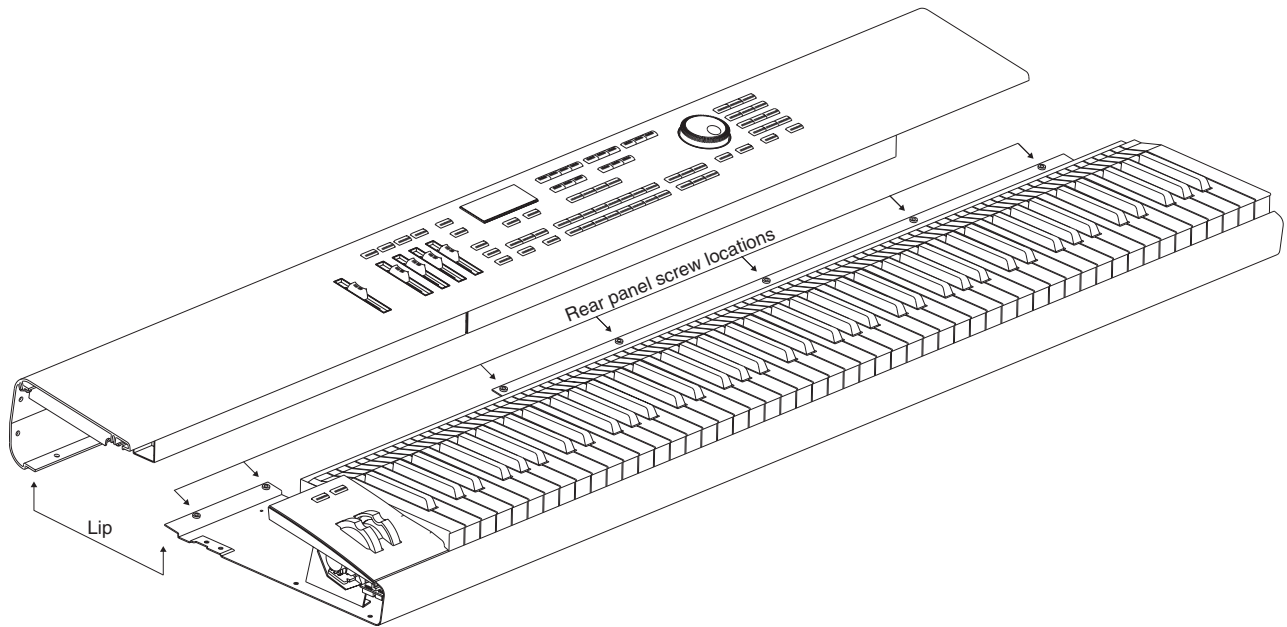
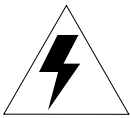

Figure 4-4 Top cover and bottom enclosure



Warning: Be sure to have your work surface prepared. This includes placing foam blocks behind the unit. When the top enclosure is removed, place it on the foam blocks to avoid damaging the Alpha Wheel, control panel buttons, and sliders. The following procedure requires enough room behind the rear of the unit to place the top enclosure face down on your work surface.

6. Grip each end of the top enclosure and rotate it back approximately two inches. This separates the bottom edges of the top enclosure and bottom enclosure.
7. Lift the top enclosure straight up.
8. Turn the top enclosure over and place it face down onto your work surface.



Caution: Table 4-1 lists the cables, by board location, from the top enclosure to the assembly they connect to on the bottom enclosure. You do not need to disconnect these cables.

Top cover Assembly	Bottom Enclosure
Connector Board	Keyboard Assembly
Connector Board	Keyboard Assembly
FP Board	Button Board/Wheel Assembly
Connector Board	Mod Wheel Assembly

Table 4-1 Top cover and bottom enclosure cables

Replacing the Top Enclosure

1. Position the top enclosure behind the bottom enclosure.
2. Move the top enclosure so that the bottom edge of the rear panel is positioned under the bottom enclosure edge. See Figure 4-4 on page 4-5.



Note: Verify that the cables listed in Table 4-1 are lying flat on the bottom enclosure. Be sure that all other cables are tucked between the top enclosure and the enclosure support walls.

3. Hold the top enclosure safely in place and move the unit so that one end of the rear panel edge hangs over the edge of your work surface and install the rear panel screw at that end. Slide the unit back onto your work surface. Repeat for other end. Refer to Figure 4-1 for the PC2 or Figure 4-2 for the PC2X.



Warning: Perform Steps 3 and 4 separately. Combining these steps could cause the top enclosure to flip away from the bottom enclosure or off of your work surface.

4. Move the unit so that the rear panel edge of the unit hangs over the edge of your work surface and install the remaining screws.



Note: If you are servicing a PC2, there are five remaining rear panel screws to install. If you are servicing a PC2X, there are seven remaining screws.

Closing the PC2/PC2X



Warning: The following procedure assumes that you have completed Steps 3 and 4 in *Replacing the Top Enclosure*. If you have not completed these steps, do so before continuing.

1. Refer to Figure 4-1 for the PC2 or Figure 4-2 for the PC2X. Tilt the unit up and install the eight enclosure support wall screws.
2. Slide one side of the unit off of your work surface and hold the appropriate endcap in position. Install the four endcap screws in the bottom enclosure. Repeat for the other endcap.
3. Refer to Figure 4-3. Install the four endcap screws in the rear panel.

Top Enclosure

The top enclosure includes five boards: Connector, Front Panel, LCD, Slider, and Engine. The Right and Left Enclosure Support Walls are also included on the top enclosure. Figure 4-5 shows the placement of the enclosure support walls. Figure 4-6 shows the placement of the boards.

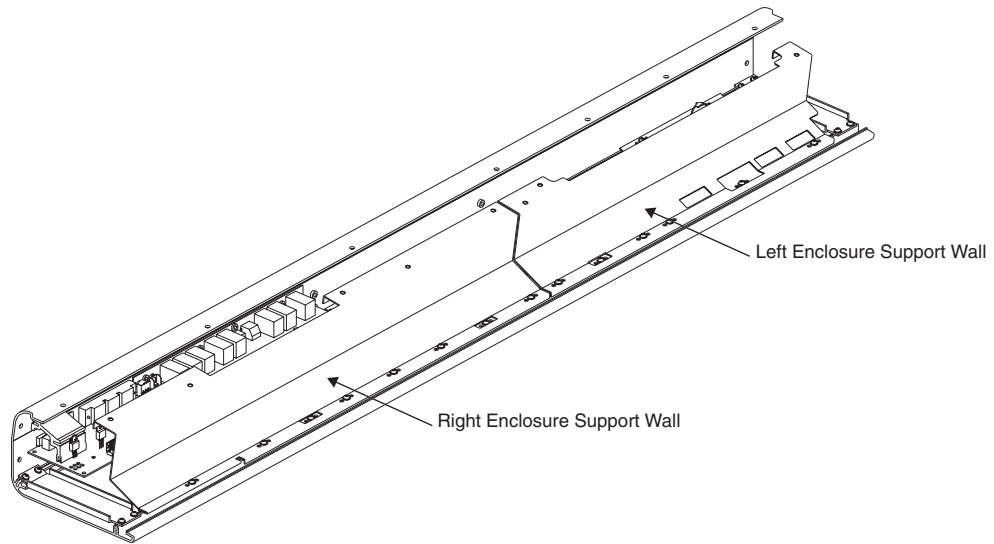

Figure 4-5 Top enclosure, enclosure support walls

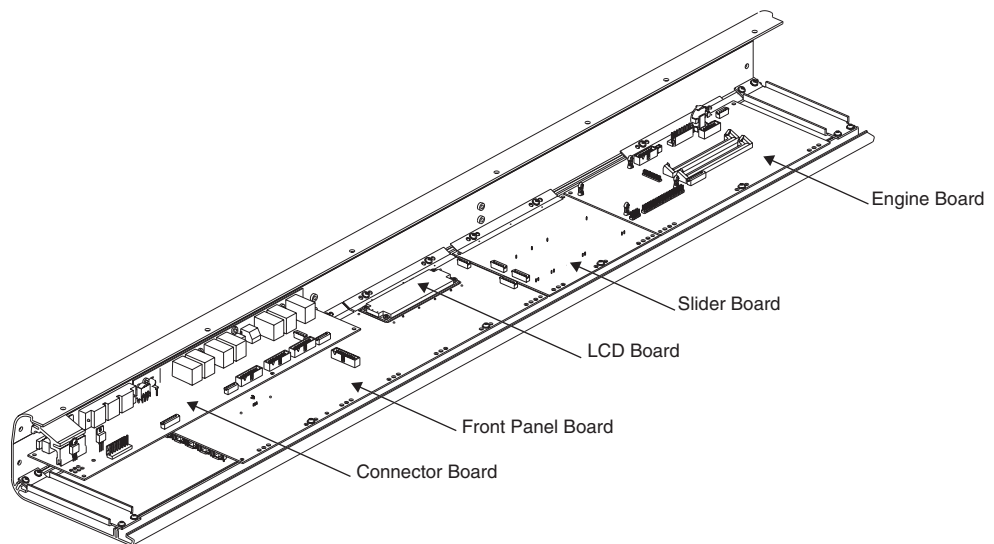

Figure 4-6 Top enclosure, board locations

Removing the Enclosure Support Walls

Left Enclosure Support Wall

1. Remove the four screws that secure the left enclosure support wall to the top enclosure, and remove the left enclosure support wall.

Right Enclosure Support Wall

1. Remove the six screws that secure the right enclosure support wall to the top enclosure, and remove the right enclosure support wall.

Replacing the Enclosure Support Walls

Left Enclosure Support Wall

1. Align the center screw holes of the three-hole groupings in the left enclosure support wall with the thread marks in the extrusion.
2. Install the four screws that secure the left enclosure support wall to the top enclosure.

Right Enclosure Support Wall

1. Align the center screw holes of the three-hole groupings in the right enclosure support wall with the thread marks in the extrusion.
2. Install the six screws that secure the right enclosure support wall to the top enclosure.

Removing the Connector Board

1. Follow the procedure described on page 4-8 to remove the right enclosure support wall.
2. Following Steps 3–5, disconnect the cables listed in Table 4-2.

Ref.	Name	Cable Type	Destination
J301	PC2 Power	stranded wire	Engine Board
J302	Audio	flat ribbon	Engine Board
J303	MIDI/CPU	flat ribbon	Engine Board
J304	Front Panel	flat ribbon	Front Panel Board
J305	Slider	flat ribbon	Slider Board
J306	Treble	flat ribbon	Keyboard Assembly
J307	Bass	flat ribbon	Keyboard Assembly
J308	Wheels	flat ribbon	Mod Wheel Assembly

Table 4-2 Connector Board cables

3. Disconnect the stranded wire cable from J301 on the Connector Board.

- Remove the cable locking clips and disconnect the flat ribbon cables from J304, J306, and J307. Be sure to set the cable locking clips safely aside so that you can install them when you reconnect the cables.



Note: The cables used throughout the PC2/PC2X are bundled and routed so that their locations and destinations seem obvious. However, to avoid reversing the Bass and Treble cables when reconnecting, mark one or both cables designating B for Bass and T for Treble.

- The flat ribbon cables connected to J302, J303, J305, and J308 use wire trap connectors. The shielding has been removed from the end of these cables to expose the wires. The wires are directly inserted into these connectors.

Lift up the sides of each connector. This unlocks the trap to free the cable wires. Gently pull each cable up out of the connector. Note the marking (red or black) on each cable that indicates the connection to Pin 1; you'll need to reconnect the marked edge of the cable to Pin 1 when you replace the Connector Board.

- Remove the five screws that secure the Connector Board to the rear panel. Two of these screws are longer than the others and have spacers located between the screw and the rear panel. See Figure 4-7 for the locations of the screws and spacers.



Note: Do not remove any other hardware from this portion of the rear panel.

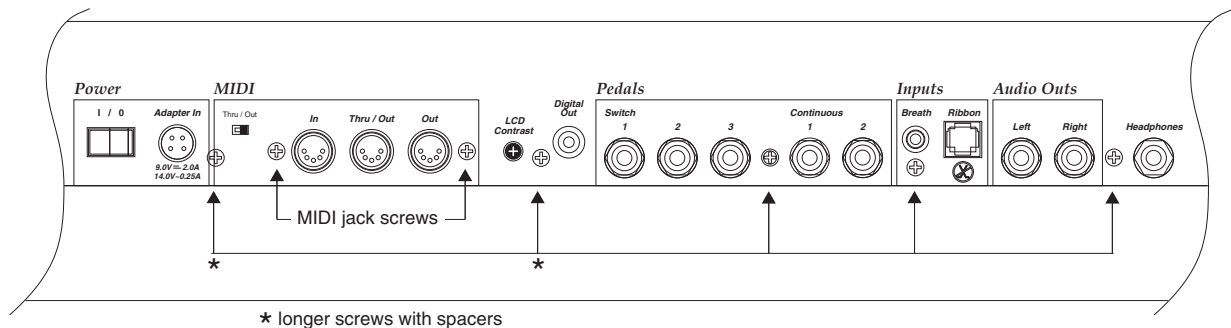

Figure 4-7 Rear panel hardware locations

- Remove the two screws that secure the MIDI jacks to the rear panel. See Figure 4-7.
- Remove the Connector Board.

Replacing the Connector Board

1. Hold the Connector Board and position it so that the power switch, LCD Contrast potentiometer, and the rear panel jacks are correctly positioned through the rear panel portion of the top enclosure.
2. Install the two screws that secure the MIDI jacks to the rear panel. See Figure 4-7.
3. Install the five screws that secure the Connector Board to the rear panel. Be sure to place a spacer and use one of the longer screws at the locations noted in Figure 4-7.
4. Connect the wire trap flat ribbon cables in the following order.



Caution: Be sure to look for the marking on the edge of the cable denoting Pin 1 and that you match it correctly with Pin 1 on the board. Make certain that the wires are straight prior to inserting them into the connector and that each wire is correctly inserted into its respective position.



Note: Be sure the sides of the connector are lifted. Insert the flat ribbon cables into the wire trap connectors and push down the sides of each connector to lock the cable into the connector. Gently pull each cable to verify that it is locked into its connector.

Insert the five-wire flat ribbon cable from the Engine Board into the wire trap connector at J302 on the Connector Board.

Insert the seven-wire flat ribbon cable from the Slider Board into the wire trap connector at J305 on the Connector Board.

Insert the six-wire flat ribbon cable from the Mod Wheel Assembly into the wire trap connector at J308 on the Connector Board.

Insert the ten-wire flat ribbon cable from the Engine Board into the wire trap connector at J303 on the Connector Board.

5. Connect the flat ribbon cables from the Keyboard Assembly to J306 and J307. Be sure to install a cable locking clip on each connector.
6. Connect the flat ribbon cable from the Front Panel Board to J304 on the Connector Board. Be sure to install a cable locking clip on the connector.
7. Connect the stranded wire cable from the Engine Board to J301 on the Connector Board.
8. Follow the procedure on page 4-8 to install the right enclosure support wall.

Removing the Front Panel Board

1. Follow the procedure described on page 4-8 to remove the right enclosure support wall.
2. Follow the procedure described on page 4-8 to remove the Connector Board.
3. Following Steps 4 and 5, disconnect the cables listed in Table 4-3.

Ref.	Name	Cable Type	Destination
J601	IBBB	flat ribbon	Button Board/Wheel Assembly
J602	FP Bridge	flat ribbon	Slider Board

Table 4-3 Front Panel Board cables

- The flat ribbon cables connected to J601 and J602 use wire trap connectors. The shielding has been removed from the end of these cables to expose the wires. The wires are directly inserted into these connectors.

Lift up the sides of each connector. This unlocks the trap to free the cable wires. Gently pull each cable up out of the connector. Note the marking (red or black) on each cable that indicates the connection to Pin 1; you'll need to reconnect the marked edge of the cable to Pin 1 when you replace the Front Panel Board.

- Remove the cable locking clip and disconnect the flat ribbon cable at J604 on the Front Panel Board. Be sure to set the cable locking clip safely aside so that you can install it when you reconnect the cable.



Note: The flat ribbon cable at location J604 was disconnected following the procedure to remove the Connector Board. It is not necessary to disconnect it from the Front Panel Board. However, if you are replacing the Front Panel Board with a replacement board, be sure to disconnect the cable and connect it to the replacement board.

- Five of the screws that secure the right enclosure support wall also secure the front panel edge of the Front Panel Board. You have already removed the enclosure support wall, but two screws remain securing this edge of the board. See Figure 4-8, and remove the two remaining screws.

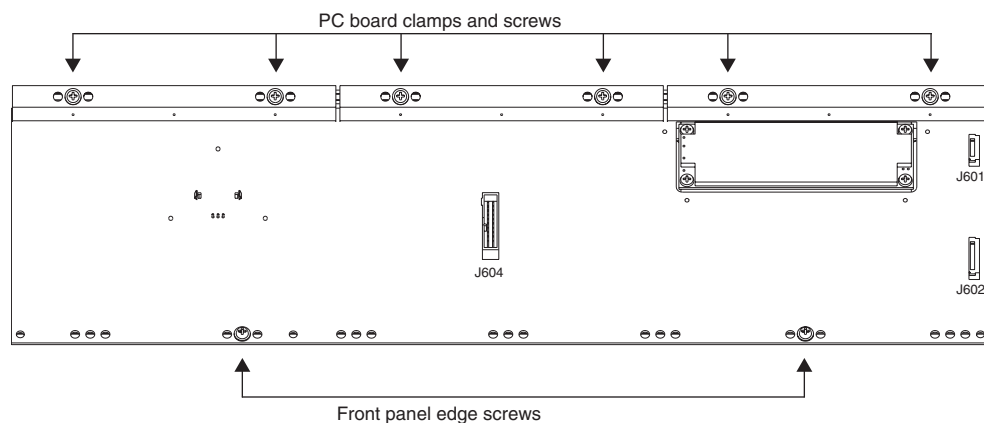

Figure 4-8 Front Panel Board, screw locations

- Remove the six screws that secure the three PC board clamps (two screws per clamp). These screws also secure the rear panel edge of the Front Panel Board.

The LCD is mounted onto a bezel that is secured to the Front Panel Board with small pegs that snap into holes on the Front Panel Board. Removing the LCD requires cutting the tie wraps that bundle the LCD cables to cable mounts positioned along the rear panel. It is not necessary to remove the LCD from the unit. Remove the four screws that secure the LCD to the front panel bezel. Lift the LCD up from the bezel and fold it over so that the circuit side of the LCD is positioned above the Slider Board. For protection, place a piece of anti-static material between the LCD and Slider Boards.

8. Lift the Front Panel Board up from the top enclosure. The spinknob and switch button caps should remain in place.



Caution: Each switch button cap uses a set of small pegs to mount the cap to the Front Panel Board. The button caps are mounted individually or in clusters. If a cap becomes separated from the board, be careful that a peg is not inadvertently broken.

Replacing the Front Panel Board

1. Position the Front Panel Board onto the top enclosure, then raise the top enclosure up slightly to verify that the spinknob and switch button caps are correctly positioned through their openings in the top enclosure.
2. Align the center screw holes of the three-hole groupings on the front panel edge of the board with the thread marks in the extrusion and install the two screws that secure the front panel edge. See Figure 4-8.
3. Place a PC board clamp in position. Align the center screw holes of the clamp with the thread marks in the extrusion and install the two screws that secure the clamp. Repeat for the other two clamps.
4. Position the LCD onto the front panel bezel and install the four screws that secure it to the bezel.
5. Connect the wire trap flat ribbon cables in the following order.



Caution: Be sure to look for the marking on the edge of the cable denoting Pin 1 and that you match it correctly with Pin 1 on the board. Make certain that the wires are straight prior to inserting them into the connector and that each wire is correctly inserted into its respective position.



Note: Be sure the sides of the connector are lifted. Insert the flat ribbon cables into the wire trap connectors and push down the sides of each connector to lock the cable into the connector. Gently pull each cable to verify that it is locked into its connector.

Insert the five-wire flat ribbon cable from the Button Board into the wire trap connector at J601 on the Front Panel Board.

Insert the eight-wire flat ribbon cable from the Slider Board into the wire trap connector at J602 on the Front Panel Board.

6. If you have disconnected the flat ribbon cable from J604, reconnect it. Be sure to install the cable locking clip.
7. Follow the procedure on page 4-10 to install the Connector Board.
8. Follow the procedure on page 4-8 to install the right enclosure support wall.

Removing the LCD Board

1. Follow the procedure described on page 4-8 to remove the right enclosure support wall.
2. Disconnect the stranded wire from location J405 on the Engine Board.
3. Remove the cable locking clip and disconnect the flat ribbon cable from J406 on the Engine Board. Be sure to set the cable locking clip safely aside so that you can install it when you reconnect the cable.
4. Removing the LCD Board requires cutting the tie wraps that bundle the LCD cables to cable mounts positioned along the rear panel. Cut the tie wraps at the cable mounts that the two LCD cables pass through.
5. Remove the four screws that secure the LCD to the front panel bezel.
6. Lift the LCD Board up and remove it.



Caution: Be sure that the LCD cables are not tangled with other cables routed along the rear panel.

Replacing the LCD Board

1. Place the LCD Board in position face down onto the front panel bezel.
2. Install the four screws that secure it to the front panel bezel.
3. Connect the stranded wire cable to J405 on the Engine Board.
4. Connect the flat ribbon cable to J406 on the Engine Board. Be sure to install the cable locking clip.
5. Position the LCD cables at the cable mounts on the rear panel and install new tie wraps through the cable mounts to bundle the cables.



Caution: Be sure that you have bundled the LCD cables with the other cables positioned at the cable mounts.

6. Follow the procedure on page 4-8 to install the right enclosure support wall.

Removing the Polyphony Expansion Board (PCX-1)

The Polyphony Expansion Board is mounted on to the Engine Board and held in place with four nylon PC board standoffs and a 24-pin female header on the underside of the board.

1. Follow the procedure described on page 4-8 to remove the left enclosure support wall.
2. Squeeze the top of one of the four nylon PC board standoffs, and lift the corner of the board until it clears that standoff. Repeat for the other three standoffs.
3. When the board is free of the standoffs, lift the board straight up to disconnect the 24-pin connector from the Engine Board.

Replacing the Polyphony Expansion Board (PCX-1)

1. Place the PCX-1 Board over the four standoffs. This should properly position the 24-pin connector over the 24-pin header on the Engine Board.
2. Press the PCX-1 Board down, securing the 24-pin connector, and snapping the board onto the standoffs.



Note: If you are installing a new PCX-1 Board, check the old board for Sound ROM options. If the unit has Sound ROM options, be sure to install them on the new board.

3. Follow the procedure described on page 4-8 to install the left enclosure support wall.

Removing the Slider Board

1. Follow the procedure described on page 4-8 to remove the left enclosure support wall.
2. If the unit you are servicing has a PCX-1 Board installed, follow the procedure on page 4-13 to remove it.
3. The flat ribbon cables connected to J101 and J102 use wire trap connectors. The shielding has been removed from the end of these cables to expose the wires. The wires are inserted directly into these connectors.

Lift up the sides of each connector. This unlocks the trap to free the cable wires. Gently pull each cable up out of the connector. Note the marking (red or black) on each cable that indicates the connection to Pin 1; you'll need to reconnect the marked edge of the cable to Pin 1 when you replace the Slider Board.

4. Two of the screws that secure the left enclosure support wall also secure the front panel edge of the Slider Board. You have already removed the enclosure support wall, but one screw remains securing this edge of the board. See Figure 4-9, and remove the remaining screw.

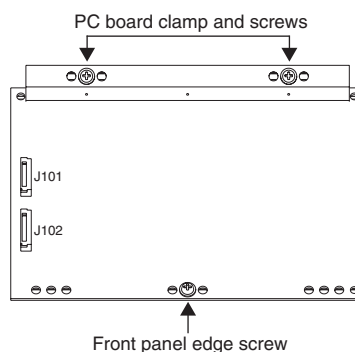

Figure 4-9 Slider Board, screw locations

5. Remove the two screws that secure the PC board clamp and rear panel edge of the Slider Board to the top enclosure.
6. Remove the Slider Board. The slider knobs, slider bezels, and switch button caps should remain in place.



Caution: Each switch button cap uses a set of small pegs to mount the cap to the Slider Board. The button caps are mounted individually or in clusters. If a cap becomes separated from the board, be careful that a peg is not inadvertently broken.

Replacing the Slider Board

1. Position the Slider Board onto the top enclosure. Raise the top enclosure up slightly to verify that the slider knobs and switch button caps are correctly positioned through their openings in the top enclosure.
2. Align the center screw hole on front panel edge with the thread marks in the extrusion and install the screw that secures the front panel edge of the Slider Board. See Figure 4-9.
3. Place the PC board clamp in position. Align the center screw holes of the PC board clamp with the thread marks in the extrusion and install the two screws that secure the PC board clamp.
4. Connect the wire trap flat ribbon cables in the following order.



Caution: Be sure to look for the marking on the edge of the cable denoting Pin 1 and that you match it correctly with Pin 1 on the board. Make certain that the wires are straight prior to inserting them into the connector and that each wire is correctly inserted into its respective position.



Note: Be sure the sides of the connector are lifted. Insert the flat ribbon cables into the wire trap connectors and push down the sides of each connector to lock the cable into the connector. Gently pull each cable to verify that it is locked into its connector.

Insert the seven-wire flat ribbon cable from the Connector Board into the wire trap connector at J101 on the Slider Board.

Insert the eight-wire flat ribbon cable from the Front Panel Board into the wire trap connector at J102 on the Slider Board.

5. If the unit you are servicing has a PCX-1 Board, follow the procedure on page 4-13 to install it.
6. Follow the procedure on page 4-8 to install the left enclosure support wall.

Removing the Engine Board

1. Follow the procedure described on page 4-8 to remove the left enclosure support wall.
2. If the unit you are servicing has a PCX-1 Board installed, remove it following the procedure described on page 4-13.
3. Following Steps 4–6, disconnect the cables listed in Table 4-4.

Ref.	Name	Cable Type	Destination
J402	PC2 PWR	stranded wire	Connector Board
J403	MIDI & CPU	flat ribbon	Connector Board
J405	Backlight	stranded wire	LCD Board
J406	LCD	flat ribbon	LCD Board
J412	PC2 Audio Out	flat ribbon	Connector Board

Table 4-4 Engine Board cables

- The flat ribbon cables connected to J403 and J412 use wire trap connectors. The shielding has been removed from the end of these cables to expose the wires. The wires are inserted directly into these connectors.

Lift up the sides of each connector. This unlocks the trap to free the cable wires. Gently pull each cable up out of the connector. Note the marking (red or black) on each cable that indicates the connection to Pin 1; you'll need to reconnect the marked edge of the cable to Pin 1 when you replace the Engine Board.

- Disconnect the stranded wire cables from J402 and J405.
- Remove the cable locking clip and disconnect the flat ribbon cable from J406. Be sure to set the cable locking clip safely aside so that you can install it when you reconnect the cable.
- Two of the screws that secure the left enclosure support wall also secure the front panel edge of the Engine Board. You have already removed the enclosure support wall, but one screw remains securing this edge of the board. See Figure 4-10, and remove the remaining screw.

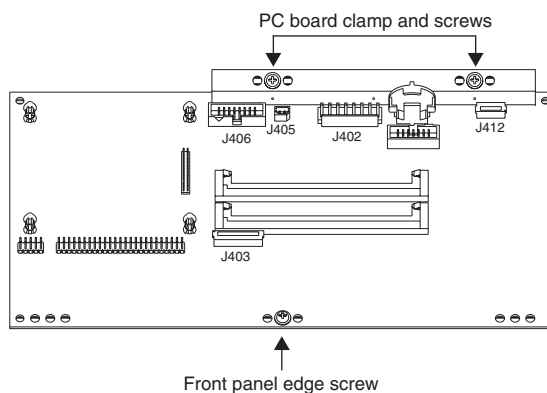

Figure 4-10 Engine Board, screw locations

- Remove the two screws that secure the PC board clamp and rear panel edge of the Engine Board to the top enclosure.
- Remove the Engine Board.

Replacing the Engine Board

1. Place the Engine Board in position on the top enclosure.
2. Align the center screw hole on the front panel edge with the thread marks in the extrusion and install the screw that secures the front panel edge. See Figure 4-10.
3. Place the PC board clamp in position. Align the center screw holes of the PC board clamp with the thread marks in the extrusion and install the two screws that secure the PC board clamp.
4. Connect the flat ribbon cable from the LCD to J406 on the Engine Board. Be sure to install the cable locking clip.
5. Connect the stranded wire cable from the LCD to J405 on the Engine Board.
6. Connect the stranded wire cable from the Connector Board to J402 on the Engine Board.
7. Connect the wire trap flat ribbon cables in the following order.



Caution: Be sure to look for the marking on the edge of the cable denoting Pin 1 and that you match it correctly with Pin 1 on the board. Make certain that the wires are straight prior to inserting them into the connector and that each wire is correctly inserted into its respective position.



Note: Be sure the sides of the connector are lifted. Insert the flat ribbon cables into the wire trap connectors and push down the sides of each connector to lock the cable into the connector. Gently pull each cable to verify that it is locked into its connector.

Insert the ten-wire flat ribbon cable from the Connector Board into the wire trap connector at J403 on the Engine Board.

Insert the five-wire flat ribbon cable from the Connector Board into the wire trap connector at J412 on the Engine Board.

8. If the unit you are servicing has a PCX-1 Board, follow the procedure on page 4-13 to install it.
9. Follow the procedure on page 4-8 to install the left enclosure support wall.

Removing the Mod Wheel Assembly

1. Refer to Figure 4-11 on page 4-19. Slide the left side of the unit forward off of your work surface so that you can access the four screws and washers securing the assembly to the bottom enclosure. Remove the four screws and washers.
2. Slide the unit back onto your work surface.
3. Lift the Mod Wheel Assembly up, approximately two inches. Nylon reinforced tape secures the Aftertouch flex cable(s) to the bottom enclosure. Peel back the tape from one side and disconnect the cable(s).



Note: If you are servicing a PC2, one flat flex cable attaches to the Mod Wheel Assembly, location J202. If you are servicing a PC2X, two flat flex cables attach to the Mod Wheel Assembly, locations J202 and J203.

4. The flat ribbon cables connected to the two boards on the Mod Wheel Assembly use wire trap connectors. The shielding has been removed from the end of these cables to expose the wires. The wires are inserted directly into these connectors.

From the Mod Wheel Assembly, disconnect the flat ribbon cable from J201 on the Wheels Board. This cable connects to J308 on the Connector Board.

From the Mod Wheel Assembly, disconnect the flat ribbon cable from J701 on the IBBB Board. This cable connects to J601 on the Front Panel Board.

Lift up the sides of each connector. This unlocks the trap to free the cable wires. Gently pull each cable up out of the connector. Note the marking (red or black) on each cable that indicates the connection to Pin 1; you'll need to reconnect the marked edge of the cable to Pin 1 when you replace the Mod Wheel Assembly.

5. Remove the Mod Wheel Assembly.

Replacing the Mod Wheel Assembly

1. Hold the Mod Wheel Assembly in position over the bottom enclosure.
2. Connect the wire trap flat ribbon cables in the following order.



Caution: Be sure to look for the marking on the edge of the cable denoting Pin 1 and that you match it correctly with Pin 1 on the board. Make certain that the wires are straight prior to inserting them into the connector and that each wire is correctly inserted into its respective position.



Note: Be sure the sides of the connector are lifted. Insert the flat ribbon cables into the wire trap connectors and push down the sides of each connector to lock the cable into the connector. Gently pull each cable to verify that it is locked into its connector.

Insert the six-wire flat ribbon cable from the Connector Board into the wire trap connector at J201 on the Wheels Board.

Insert the five-wire flat ribbon cable from the Front Panel Board into the wire trap connector at J701 on the IBBB Board.

3. Connect the flat flex cable(s).



Note: If you are servicing a PC2, connect the flat flex cable to location J202 on the Mod Wheel Assembly. If you are servicing a PC2X, connect the two flat flex cables to locations J202 and J203 on the Mod Wheel Assembly.

4. Reapply the nylon reinforced tape to the flat flex cable(s).
5. Lower the Mod Wheel Assembly into position.
6. Slide the unit forward and install the four screws and washers to secure the Mod Wheel Assembly to the bottom enclosure.

PC2 Keyboard Assembly

This section describes the removal and replacement of the PC2 (76-note) Keyboard Assembly. See page 4-26 for the corresponding procedures for the PC2X (88-note) Keyboard Assembly.

Removing the PC2 Keyboard Assembly

The following procedure assumes that the PC2 is open and that you have followed the instructions on page 4-4 to remove the top enclosure.

The PC2 keyboard is mounted onto a wooden spacer and is secured to the wooden spacer with 16 screws. The Keyboard Assembly refers to the keyboard and the wooden spacer. The assembly is secured to the bottom enclosure with eight screws.



Note: The following steps describe the procedure to remove the keyboard from the PC2 and the wooden spacer to gain access to the keys, contacts, contact boards, and key weights. If you need to gain access to the keys only (i.e. key replacement), you can do so by following the procedure described on page 4-21, *Disconnecting the PC2 Keyboard*.

1. Refer to Figure 4-11. This illustration shows the locations of the keyboard and keyboard wooden spacer screws. Both sets of screws are accessible from the bottom enclosure.

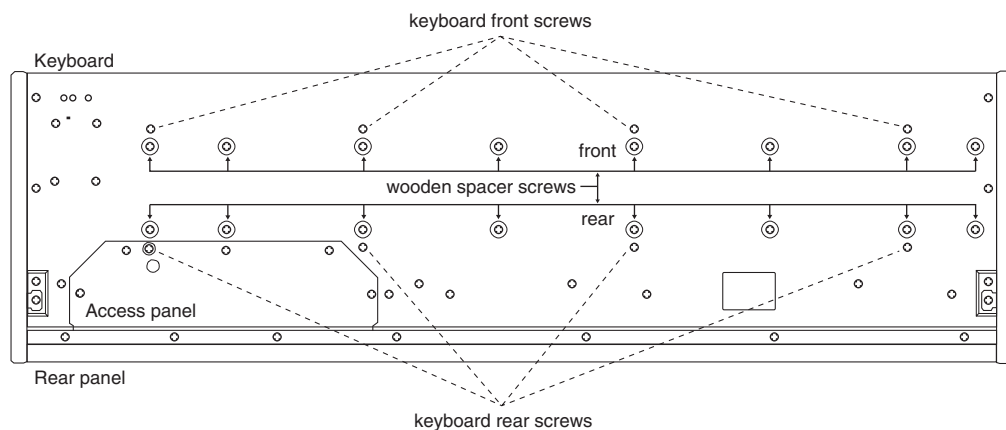

Figure 4-11 PC2 76-note keyboard bottom

2. Tilt the PC2 up and remove the four keyboard rear screws, then lay the PC2 flat on your work surface.
3. Move the PC2 forward so that the front hangs over the edge of your work surface, giving you access to the remaining screws.
4. Remove the four keyboard front screws.
5. Remove the four Mod Wheel screws and washers. At this point the keyboard is loose in the bottom enclosure, but it has cables connected to the Mod Wheel Assembly, the Connector Board, and the Front Panel Board.
6. Slide the PC2 back onto your work surface.

7. Lift the Mod Wheel Assembly and disconnect the Aftertouch flex cable. This cable has nylon reinforced tape securing it to the bottom enclosure. Peel back the tape from one side to free the cable.
8. Place the Mod Wheel Assembly in its position on the bottom enclosure.
9. Remove the cable locking clips and disconnect the flat ribbon cables from locations J306 (Treble) and J307 (Bass) on the Connector Board. These cables are also secured to the bottom enclosure with nylon reinforced tape. Peel back the tape from one side to free the cables.
10. Remove the Keyboard Assembly.
11. The keyboard is mounted onto a wooden spacer. Sixteen screws secure the spacer to the keyboard.
12. Lay the Keyboard Assembly upside down on a flat protected surface and remove the 16 screws and remove the spacer. You can now access the components of the Keyboard Assembly.

Replacing the PC2 Keyboard Assembly



Note: If you have disconnected the Bass and Treble ends of the flat ribbon cables from the keyboard contact boards during service, be sure that you have reconnected them and reapplied the tape to secure the connectors.

1. Place the keyboard upside down on a flat protected surface and position the wooden spacer over the keyboard. Install the 16 screws that secure the wooden spacer to the keyboard.
2. Place the Keyboard Assembly on the bottom enclosure. Be sure that the flat ribbon cables from the keyboard are correctly positioned.
3. Connect the flat ribbon cables to the Connector Board and reapply the cable locking clips. Be sure to reapply the nylon reinforced tape that secures the flat ribbon cable to the bottom enclosure.
4. Lift the Mod Wheel Assembly and connect the Aftertouch flex cable. Be sure to reapply the nylon reinforced tape that secures the flex cable to the bottom enclosure. Place the Mod Wheel Assembly in its position on the bottom enclosure.
5. Move the PC2 forward so that the front hangs over the edge of your work surface, and install the four keyboard front screws.
6. Install the four Mod Wheel Assembly screws and washers.
7. Slide the PC2 back onto your work surface.
8. Tilt the PC2 up and install the four keyboard rear screws.

Disconnecting the PC2 Keyboard

Follow this procedure if you are merely replacing one or more keys.

1. Refer to Figure 4-11.
2. Tilt the PC2 up and remove the four keyboard rear screws, then lay the PC2 flat on your work surface.
3. Move the PC2 forward so that the front hangs over the edge of your work surface, giving you access to the remaining screws.
4. Remove the four keyboard front screws.



Caution: The keyboard Aftertouch flex cable from the keyboard is connected to the Mod Wheel Assembly and is secured to the bottom enclosure with reinforced tape. When following the instructions below, be certain that you only slightly lift or move the Keyboard Assembly to avoid damage to the flex cable.

5. The 16 screws that secure the keyboard to the wooden spacer rest in holes provided for them on the bottom enclosure. To move the keyboard, lift the keyboard up slightly to free the 16 screws from their positions on the bottom enclosure.
6. Lift the keyboard up and move it approximately one inch to the right (as viewed standing at the keyboard).
7. You can now move the keyboard back approximately one inch toward the rear so that you can remove keys for replacement. See page 4-22 for the procedure to remove and replace keys.

Connecting the Keyboard

1. Position the keyboard so that the 16 screws that secure the wooden spacer to the keyboard are resting in the holes provided for them on the bottom enclosure.



Caution: Be certain that the Aftertouch flex cable is correctly positioned and that the nylon reinforced tape securing it to the bottom enclosure is still properly applied.

2. Refer to Figure 4-11.
3. Move the PC2 forward so that the front hangs over the edge of your work surface, and install the four keyboard front screws.
4. Slide the PC2 back onto your work surface.
5. Tilt the PC2 up and install the four keyboard rear screws.

Removing Keys

The following procedure assumes you have removed the top enclosure from the PC2.

1. Follow the procedure for removing the keyboard (page 4-19) or disconnecting the keyboard (page 4-21).
2. The following diagrams illustrate the outlines of the natural and sharp keys and the locations and functions of the components described in the following procedures.

Natural/White Key

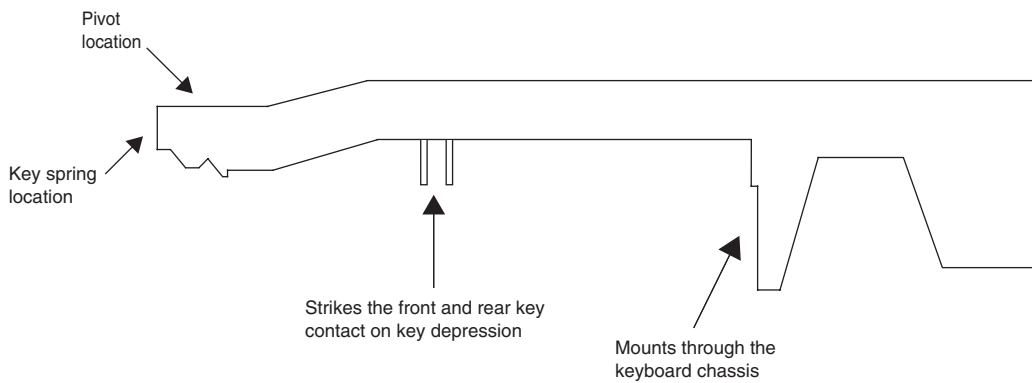

Figure 4-12 Natural/White key, 76-note keyboard

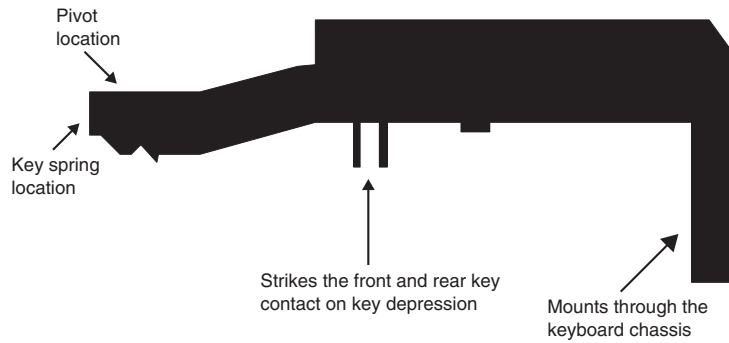

Figure 4-13 Sharp/Black key, 76-note keyboard

Natural/White Keys

1. Each key has a spring located at the rear of the key. Using needle-nose pliers, slightly pull up the top portion of the spring to release it from the key.



Caution: Be careful not to pull up too much, which could damage the spring.

2. Unlock the key from the pivot anchoring the key to the keyboard chassis. To do this, insert a small flat screwdriver at the back end of the pivot and press toward the front edge of the keyboard. While doing so, lift the back end of the key (where the spring was positioned).

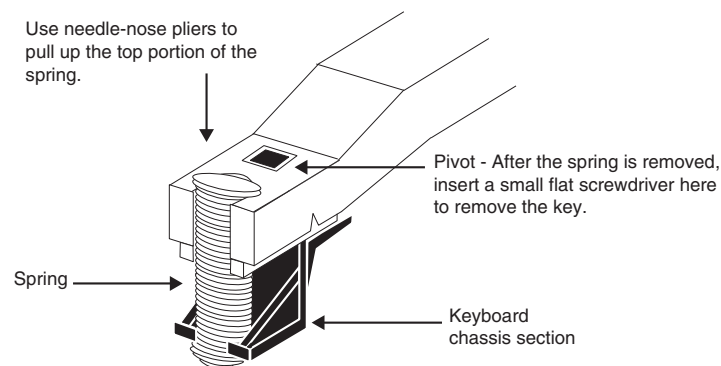

Figure 4-14 Key spring location, 76-note keyboard

3. The key should now be free of the pivot. Remove the screwdriver.
4. Lift the key up slightly, then forward. You should be able to feel when the key is free of the pivot. A portion of the key hooks onto the keyboard chassis (see Figure 4-12). Lifting the back end of the key forward unhooks the key from the keyboard chassis.

Sharp/Black Keys

1. To remove a sharp key, first remove the adjacent natural keys, as described in the previous procedure.
2. Each key has a spring located at the rear of the key. Using needle-nose pliers, slightly pull up the top portion of the spring to release from the key.



Caution: Be careful not to pull up too much, which could damage the spring.

3. Unlock the key from the pivot anchoring the key to the keyboard chassis. To do this, insert a small flat screwdriver at the back end of the pivot and press toward the front edge of the keyboard. While doing so, lift the back end of the key (where the spring was positioned).
4. The key should now be free of the pivot. Remove the screwdriver.
5. Lift the key up slightly, then forward. You should be able to feel when the key is free of the pivot. A portion of the key hooks onto the keyboard chassis (see Figure 4-13). Lifting the back end of the key forward unhooks the key from the keyboard chassis.

Replacing a Key

The following instructions apply to both natural and sharp keys.



Note: Always replace a sharp key before replacing the adjacent natural keys.

1. Place the key on the keyboard chassis and lower the key into position.
2. Align the pivot with the hole at the rear of the key. Push down on the key. It should snap into position on the pivot.
3. Install the spring.

Servicing the Keyboard Contact Boards

Follow the procedure on page 4-19 to remove the Keyboard Assembly.

1. Place the keyboard upside down on a flat soft surface. Be sure that the keys are resting on a soft surface to avoid scratching or other damage. The Treble and Bass Contact Boards are now visible.

Removing the Treble Contact Board

1. Peel back the nylon tape securing the connector, and disconnect the flat ribbon cable from the Treble Contact Board.
2. Remove the 24 screws that secure the Treble Contact Board to the keyboard chassis, and remove the Treble Contact Board.

Replacing the Treble Contact Board

1. Position the Treble Contact Board on the keyboard chassis. Be sure that the rubber key contacts line up properly through the holes in the keyboard chassis.
2. Install the 24 screws that secure the board to the keyboard chassis.
3. Connect the treble end of the flat ribbon cable and reapply the nylon tape to the connector.

Removing the Bass Contact Board

1. Peel back the nylon tape securing the connector, and disconnect the flat ribbon cable from the Bass Contact Board.
2. Remove the 18 screws that secure the board to the keyboard chassis, and remove the Bass Contact Board.

Replacing the Bass Contact Board

1. Position the Bass Contact Board on the keyboard chassis. Be sure that the rubber key contacts line up properly through the holes in the keyboard chassis.
2. Install the 18 screws that secure the board to the keyboard chassis.
3. Connect the bass end of the flat ribbon cable and reapply the nylon tape to the connector.

Removing the Keyboard Contact Strips

1. Place the keyboard upside down on a flat soft surface. Be sure that the keys are resting on a soft surface to avoid scratching or other damage.
2. Follow the procedure for removing the Bass and Treble Keyboard Contact Boards on page 4-24.
3. Examine the keyboard contact strips and look at the design of an individual contact. The top portion of the contact has two indentations. One indentation is deeper than the other. When replacing the keyboard contact strips, the deeper indentation is always positioned toward the rear of the key.
4. The keyboard contact strips have mounting pegs that secure the contact strips to the keyboard contact boards.
5. To remove a keyboard contact strip, gently lift and free the strip from its position. Be careful not to rip or damage any contact in the process.

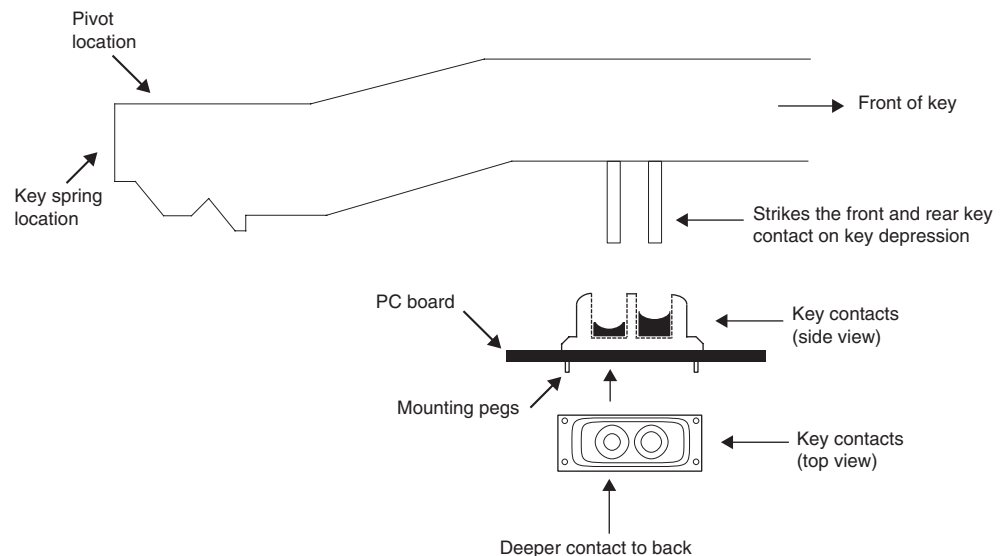

Figure 4-15 Side view of the natural/white key, 76-note keyboard

Replacing the Keyboard Contact Strips

1. Position the contact strip on the keyboard contact board.



Note: Be sure that the deeper indentation is positioned toward the rear of the key.

2. Line up the contact strip mounting pegs with their respective mounting holes on the keyboard contact board.
3. Using a small blunt-end tool (Q-Tip, toothpick, etc.), gently push the mounting pegs through the holes. Do not use too much force or use a tool that can poke a hole through the mounting pegs. However, be sure that the mounting pegs are installed through the holes.

PC2X Keyboard Assembly

Removing the PC2X Keyboard Assembly

The following procedure assumes that the PC2X is open and that you have followed the instructions to remove the top enclosure.

1. The keyboard is secured to the bottom enclosure using ten screws. Refer to Figure 4-16 for the position of the screws. Arrows identify the locations of the ten screws.
2. Tilt the PC2X up and remove the five keyboard rear screws, then lay the PC2X flat on your work surface.
3. Move the PC2X forward so that the front hangs over the edge of your work surface to access the remaining screws, and remove the five keyboard front screws.
4. Remove the four Mod Wheel screws and washers. At this point the keyboard is loose in the bottom enclosure, but it has cables connected to the Mod Wheel Assembly and the Connector Board.

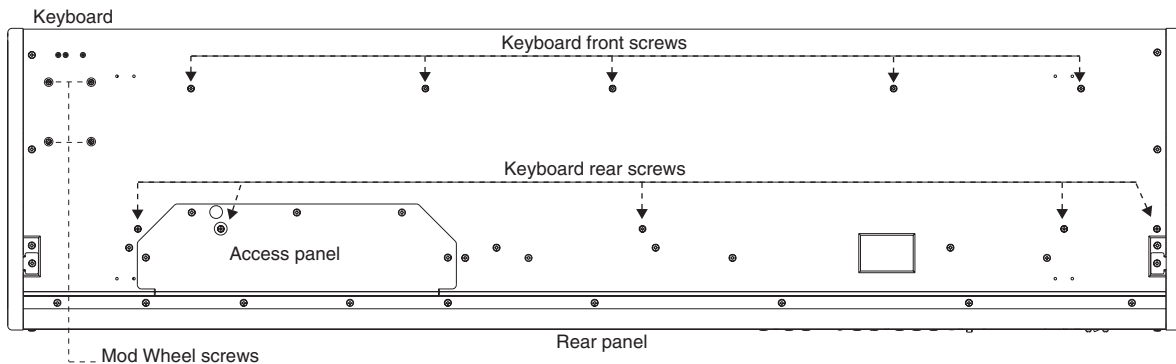

Figure 4-16 PC2X 88-note keyboard bottom

5. Slide the PC2X back onto your work surface.
6. Lift the Mod Wheel Assembly and disconnect the Aftertouch flex cables. These cables have nylon reinforced tape securing them to the bottom enclosure. Peel back the tape from one side to free the cables.
7. Place the Mod Wheel Assembly in its position on the bottom enclosure.
8. Remove the cable locking clips and disconnect the flat ribbon cables from locations J306 and J307 on the Connector Board. These cables are also secured to the bottom enclosure with nylon reinforced tape. Peel back the tape from one side to free the cables.



Note: If you are merely replacing one or more keys, it is not necessary to entirely remove the Keyboard Assembly from the PC2X. Follow the procedure on page 4-27.

9. Remove the Keyboard Assembly.

Replacing the PC2X Keyboard Assembly

1. Place the keyboard on the bottom enclosure. Be sure that the flat ribbon cables from the keyboard are correctly positioned to connect them to the Connector Board.



Note: If you have disconnected the Bass and Treble ends of the flat ribbon cables from the keyboard contact boards during service, be sure that you have reconnected them and secured them with tape. Be sure that the small ribbon cable connecting the Bass and Treble Contact Boards is connected.

2. Connect the flat ribbon cables to J306 and J307 on the Connector Board and reapply the cable locking clips.
3. Secure the flat ribbon cables to the bottom enclosure. Be sure to reapply the nylon reinforced tape that secures the cables to the bottom enclosure.
4. Lift the Mod Wheel Assembly and connect the Aftertouch flex cables. Be sure to reapply the nylon reinforced tape that secures the flex cables to the bottom enclosure.
5. Slide the PC2X forward so that you can install the five keyboard front screws.
6. Install the four Mod Wheel Assembly screws and washers.
7. Slide the PC2X back on to your work surface.
8. Tilt the PC2X up and install the five keyboard rear screws.

Removing Keys

The following procedure assumes you have removed the top enclosure from the PC2X.

1. Follow the procedure for removing the keyboard.



Note: If you are merely replacing one or more keys, it is not necessary to entirely remove the keyboard from the PC2X. Once the keyboard is loose, you can slide it toward the rear panel to give you enough access to remove keys.

2. The following diagrams illustrate the outlines of the natural and sharp keys and the location and functions of the components described in the following procedures.

Natural/White Key

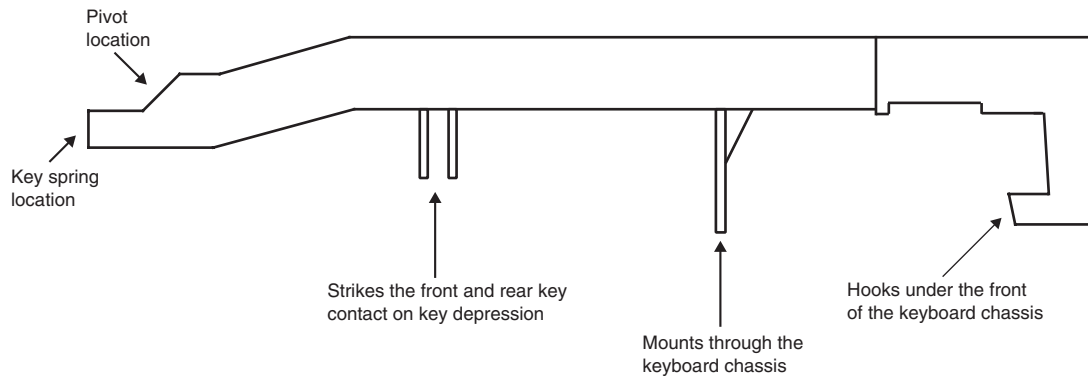

Figure 4-17 Natural/white key, 88-note keyboard

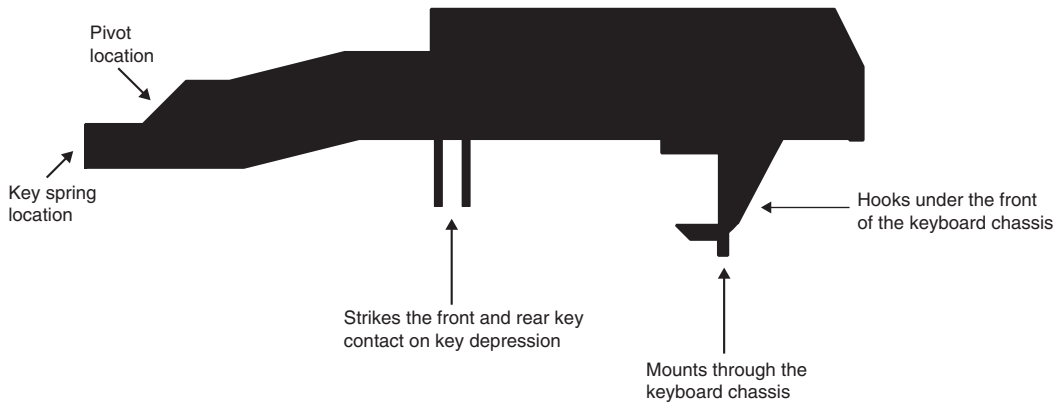

Figure 4-18 Sharp/black key, 88-note keyboard

Natural/White Keys

1. Remove the silver key spring located at the rear of the key. You will notice that the bottom of the spring is secured to the keyboard chassis by a hook.

You can remove the spring by inserting a dowel (3mm diameter) into the spring, and pushing down on it slightly. Then pull the top of the dowel toward the front of the keyboard. This will unhook the spring from the keyboard chassis.

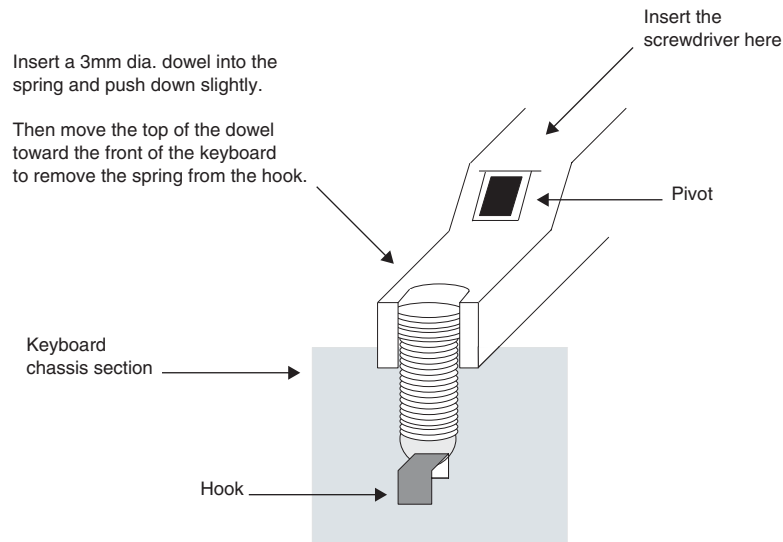

Figure 4-19 Key spring

2. Unlock the key from the pivot anchoring the key to the keyboard chassis. To do this, insert a small flat screwdriver at the back end of the pivot and press toward the front edge of the keyboard. While doing so, lift the back end of the key (where the spring was positioned).
3. The key should now be free of the pivot. Remove the screwdriver.
4. Lift the key up slightly, then forward. You should be able to feel when the key is free of the pivot. The front edge of each key hooks under the keyboard chassis. Be sure the key is not hooked under the keyboard chassis prior to lifting the key off.

Sharp/Black Keys

1. To remove a sharp key, first remove the adjacent natural keys, as described in the previous procedure.
2. Remove the gold key spring located at the rear of the sharp key. You will notice that the bottom of the spring is secured to the keyboard chassis by a hook.

Refer to Figure 4-19. You can remove the spring by inserting a dowel (3mm diameter) into the spring, and pushing down on it slightly. Then pull the top of the dowel toward the front of the keyboard. This will unhook the spring from the keyboard chassis.

3. Unlock the key from the pivot anchoring the key to the keyboard chassis. To do this, insert a small flat screwdriver at the bottom of the pivot and press toward the front edge of the keyboard. While doing so, lift the back end of the key (where the spring was positioned).
4. The key should now be free of the pivot. Remove the screwdriver.
5. Lift the key up slightly, then forward. You should be able to feel when the key is free of the pivot. The front edge of each key hooks under the keyboard chassis. Be sure the key is not hooked under the keyboard chassis prior to lifting the key completely off.

Replacing a Key

1. The following instructions apply to both natural and sharp keys.



Note: Always replace a sharp key before replacing the adjacent natural keys.

2. Hook the front end of the key under the keyboard chassis.
3. Check that the mounting peg is correctly positioned.
4. Lower the key into position. Align the pivot with the hole at the rear of the key.
5. Push down on the key. It should snap into position onto the pivot.
6. Install the spring.

Servicing the Keyboard Contact Boards

1. Place the keyboard upside down on a flat soft surface. Be sure that the keys are resting on a soft surface to avoid scratching or other damage. The Treble and Bass Contact Boards are now visible.

Removing the Treble Contact Board

1. Disconnect the flat ribbon cable that connects the Treble Contact Board to the Connector Board. The connector is secured with tape. Peel back the tape to free the cable.
2. Disconnect the small ribbon cable that connects the Treble and Bass Contact Boards.
3. Remove the 26 screws that secure the Treble Contact Board to the keyboard chassis, and remove the Treble Contact Board.

Replacing the Treble Contact Board

1. Position the Treble Contact Board on the keyboard chassis. Be sure that the rubber key contacts line up properly through the holes in the keyboard chassis.
2. Install the 26 screws that secure the board to the keyboard chassis.
3. Connect the small ribbon cable that connects the Treble to the Bass Contact Board.
4. Connect the flat ribbon cable that connects the Treble Contact Board to the Connector Board. Be sure to reapply the tape to secure the connector.

Removing the Bass Contact Board

1. Disconnect the flat ribbon cable that connects the Bass Contact Board to the Connector Board. The connector is secured with tape. Peel back the tape to free the cable.
2. Disconnect the small ribbon cable that connects the Bass and Treble Contact Boards.
3. Remove the 22 screws that secure the board to the keyboard chassis, and remove the Bass Contact Board.

Replacing the Bass Contact Board

1. Position the Bass Contact Board on the keyboard chassis. Be sure that the rubber key contacts line up properly through the holes in the keyboard chassis.
2. Install the 22 screws that secure the board to the keyboard chassis.
3. Connect the small ribbon cable that connects the Bass to the Treble Contact Board.
4. Connect the flat ribbon cable that connects the Bass Contact Board to the Connector Board. Be sure to reapply the tape to secure the connector.

Removing the Keyboard Contact Strips

1. Place the keyboard upside down on a flat soft surface. Be sure that the keys are resting on a soft surface to avoid scratching or other damage.
2. Follow the procedure to remove the Bass and Treble Keyboard Contact Boards.
3. Examine the keyboard contact strips and look at the design of an individual contact. The top portion of the contact has two indentations. One indentation is deeper than the other. When replacing the keyboard contact strips, the deeper indentation is always positioned toward the rear of the key.
4. The keyboard contact strips have mounting pegs that secure the contact strips to the keyboard contact boards.
5. To remove a keyboard contact strip, gently lift and free the strip from its position. Be careful not to rip or damage any contact in the process.

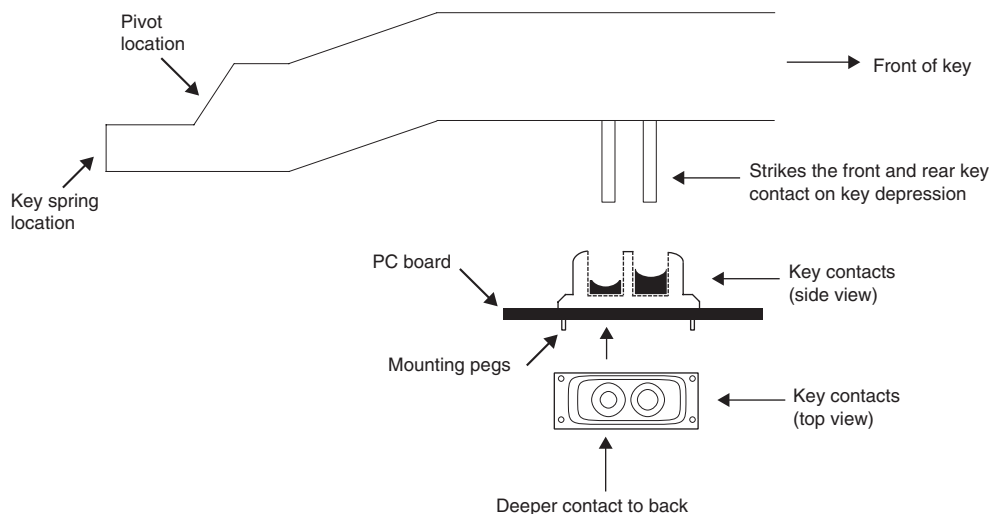

Figure 4-20 Side view of the natural/white key, 88-note keyboard

Replacing the Keyboard Contact Strips

1. Position the contact strip on the Keyboard Contact Board that you are servicing.



Note: Be sure that the deeper indentation is positioned toward the rear of the key.

2. Line up the contact strip mounting pegs with their respective mounting holes on the keyboard contact board.
3. Using a small blunt-end tool (Q-Tip, toothpick, etc.), gently push the mounting pegs through the holes. Do not use too much force or use a tool that can poke a hole through the mounting pegs. However, be sure that the mounting pegs are installed through the holes.

Removing a Key Weight

1. The main components of the weighted-key action consist of the following: the 88 keys, two rods, 88 key weights, and support brackets for the key weights and rods. There are seven 12-position brackets and one 4-position bracket.



Note: Key weights are attached to one of the two rods that span the length of the keyboard. The first rod is referred to as the bass rod and the second rod is referred to as the treble rod. The first rod (the bass rod) begins at low A and extends to G# above Middle C. The second rod (the treble rod) begins at A above Middle C and extends to High C.

2. To replace a key weight, identify the section with the broken key weight and remove all the keys from that section. The key weights, rods, and support brackets are now visible.
3. There is a locking clip at each end of the keyboard. To remove the locking clips, use a standard screwdriver to pry the locking clips off.
4. Pry the rod up from the support bracket. The key weights remain attached to the rod.
5. To remove the key weights from the rod, move the key weight side to side and pull it away from the rod. The key weight should easily pop off the rod.



Note: The natural and sharp key weights are physically different. The sharp key weights are smaller. When you remove multiple key weights, do so in a way that you will be able to place the new natural and sharp key weights in their correct positions.

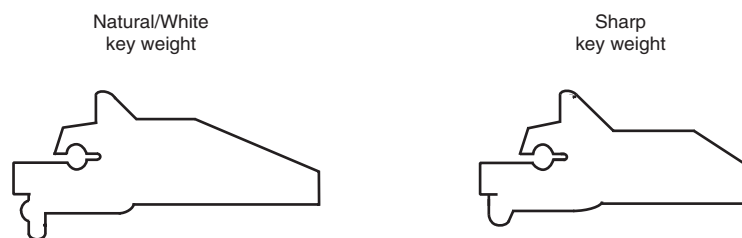

Figure 4-21 Natural/White and Sharp/Black key weights

6. Remove the broken key weight(s) and inspect the other key weights for reliability.

Replacing a Key Weight

1. Each key weight has a strip of red felt attached with pliable adhesive. Be sure the red felt extends onto the upper surface of the top of the key weight.
2. Place the key weight in position against the rod and snap it onto the rod with slight pressure.



Note: Be sure to place the sharp key weights in the correct positions.

3. Place the rod and key weights into position over the support brackets and snap the rod into the support brackets. Be certain that the rod is pressed securely into the support brackets.
4. Prior to replacing the keys, check that each key weight moves freely. To do this, position a screwdriver at the back end of the key weight (on the red felt), press down and remove the screwdriver. The key weight should move up and down freely.
5. Install the keys and key springs.

Chapter 5

Troubleshooting

Introduction

Cables, Connectors

Flat Ribbon Cables

All flat ribbon cables with connectors are keyed, and therefore cannot be reversed. Most flat ribbon cables have locking cable clips. Be sure to reapply the clips when connecting cables. Flat ribbon cables that connect to picoflex connectors do not have locking cable clips.

Some flat ribbon cables have exposed wires that insert directly into a wire trap connector. When disconnecting and connecting these cables, you must look for the marking on the edge of the cable denoting Pin 1 and be sure that you match it correctly with Pin 1 on the board.

Cable Routing

In some cases, tape secures cable connections or fastens cables to the bottom enclosure. Always peel back the tape from one side when disconnecting cables so that the tape remains properly positioned.

Surface-Mount Devices

The removal and replacement of surface-mount devices requires training and the proper equipment. If you do not have the training or equipment to remove or replace surface-mount devices, contact the service department to order a board replacement. International service technicians should contact their appropriate Young Chang Distributor.

Saving User Data

1. Set up a MIDI recording device.
 2. Connect the a MIDI cable to the MIDI Out port of the PC2 to the MIDI In port on the external device.
 3. Press the **Global** button on the PC2. Press the **Right** cursor button until the LCD displays **Dump all Objects?**
 4. Begin recording on the MIDI recording device.
 5. Press **Enter** on the PC2. The LCD shows the objects being saved. When all objects are saved, **Dump all Objects?** will appear in the LCD.
 6. To reload the saved objects, connect a MIDI cable from the MIDI Out port of the recording device to the PC2's MIDI In port.
 7. From the external device, begin the playback of the file.
-

Boot Block

Use the PC2's Boot Loader to enter Diagnostics or perform a Hard Reset to the unit. You can also install operating system updates and ROM objects into Flash ROM.

Entering the Boot Block

Apply power to the unit. When the **Please wait...** message appears in the LCD, quickly press and release the **Panic** button for PC2 keyboard units or **Edit** button for PC2R rack units.

The LCD displays the main menu of the Boot Loader and the first available option. Use the **Left** or **Right** cursor button to advance to the next option. The menu options are as follows:

Install Engine—Installs new operating system software upgrades.

Install ROM option—Loads Sound ROM presets after installing a Sound ROM option.

Update boot block—Installs boot block updates.

Run diagnostics—Enters the diagnostic test menu. For a complete list of tests and the procedure to execute the diagnostic tests, refer to Chapter 2, *Diagnostics*.

Run engine—Exits the boot block and returns the unit to normal operation.

Hard RESET—Clears the memory to factory default settings.

Resets

Hard Reset

There are two ways to perform a Hard Reset to the PC2.

1. Press the **Global** button and press the **Right** cursor button to step through the Global parameters to **Reset PC2?** and press the **Enter/Yes** button. The LCD displays an **Are you sure?** message. Press the **Enter/Yes** button to continue or the **Cancel/No**.
2. Enter the Boot Loader and press either the **Left** or **Right** cursor button to scroll through the menu. Press **Enter** to select Hard Reset. The LCD displays an Erase RAM objects? message. Press the **Right** button to execute the hard reset. Press the **Left** button to cancel.

Soft Reset

The Soft Reset does not erase user programs and setups and is equivalent to turning the power off and on. To Soft Reset a PC2R, simultaneously press the **FX**, **MIDI Receive** and **Global** buttons. To Soft Reset a PC2, simultaneously press the **+/-**, **0** and **Clear** buttons.

Software Updates

A computer with a MIDI interface and sequencer is necessary to transfer software to your PC2 units MIDI Sysex.

File Formats

Software upgrades are stored as standard MIDI files. Filenames are in the format **PC2XVV.MID**, where **X** is the software block and **VVV** is the version number (**V.VV**). The following lists the possible values for **X**. Never install files with names that don't conform to this format; it won't work.

bk—boot block for keyboard models

br—boot block for rack models

bp—boot block for Polyphony Expansion (PCX-1) option (keyboard and rack units)

k—operating system software for keyboard models

r—operating system software for rack models

p—operating system for Polyphony Expansion (PCX-1) option (keyboard and rack models)

s—soundware data for keyboard and rack models

sp—soundware data for Polyphony Expansion (PCX-1) option (keyboard and rack models)

Installing the Operating System or Setups



Warning: This procedure requires performing a hard reset. All user programs and setups will be erased. Before continuing, be sure to save all user programs and setups.

1. Connect a MIDI cable from the MIDI Out port of the computer interface or sequencer to the MIDI In port on the PC2.
2. Open the first **.MID** file using the sequencer program.
3. Turn on the PC2 and follow the procedure to enter the Boot Block.
4. Press the **Enter** button to select **Install engine**.
5. Press the **Enter** button to select **via MIDI**.
6. The LCD shows **Waiting for MIDI**. Start playing the MIDI file from the sequencer. While a file is loading, the bottom line of the display shows the progress. If the display continues to show **Waiting for MIDI** after starting the sequencer, stop and restart the sequence.
7. After the file is loaded, the display will show **done**.
8. If you have additional files to load, open the file from the sequencer and begin playing it.
9. Press the **Cancel** button twice to return to the main menu. Scroll to Hard Reset and select **Yes**.

Installing a New Boot Block



Warning: This procedure performs a hard reset. All user programs and setups will be erased. Before continuing, be sure to save all user programs and setups.

1. Connect a MIDI cable from the MIDI Out port of the computer interface or sequencer to the MIDI In port on the PC2.
2. Using the sequencer program, open the first **.MID** file.
3. Turn on the PC2 and follow the procedure to enter the Boot Block.
4. Press the **Enter** button to select **Update boot block**.
5. Press the **Enter** button to select **via MIDI**.
6. The LCD shows **Waiting for MIDI**. Start playing the MIDI file from the sequencer. While a file is loading, the bottom line of the display shows the progress. If the display continues to show **Waiting for MIDI** after starting the sequencer, stop and restart the sequence.
7. After the file is loaded, the unit will reset.

Installing Sound ROM Options

After installing a Sound ROM option, the presets need to be transferred into Flash ROM.



Warning: This procedure requires performing a hard reset. All user programs and setups will be erased. Before continuing, be sure to save all user programs and setups.

1. Turn on the PC2 and follow the procedure to enter the Boot Block.
2. Use the **Left** or **Right** cursor button to scroll to **Install ROM option**, and press the **Enter** button.
3. Use the **Left** or **Right** cursor button to select the appropriate option for the card you are installing, **card 1** or **card 2**.
4. Press the **Enter** button. The LCD indicates **Installing** as the presets transfer into Flash ROM.

Note: If you are installing a second ROM option repeat Steps 3 and 4.



5. Use the **Left** or **Right** cursor button to scroll to **Hard Reset**, and press the **Enter** button.
6. Select **Yes** to hard reset the unit. The unit now has the additional ROM option setups installed.

Replacing the Battery

The PC2 uses a flat three volt Lithium coincell battery. When the battery voltage runs low, the unit boots up with a low battery message.



Note: The battery voltage can be checked at anytime using the Scanner Diagnostics. See page 5-7 for more information.

PC2 Keyboard Models

Accessing the Battery

1. Place the PC2 upside down on a flat protected surface.
2. Remove the seven screws that secure the access panel and set it safely aside.
3. If the unit has Sound ROM options installed, remove them.

Removing the Battery

The battery (CR2032) in the PC2 keyboard is mounted into a holder on the Engine Board and is accessible when the access panel is removed.

1. Insert a flat plastic tool (plastic knife, pen cap, etc.) into one of the openings between the battery and the holder to lift the battery.

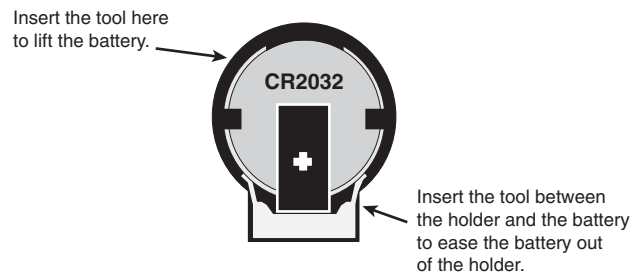

Figure 5-1 Battery and holder

2. Ease the battery out of the holder. If necessary, insert the plastic tool at the bottom of the holder (closest to the Engine Board) to remove the battery.

Installing the Battery

1. Position the battery over the holder so that the positive terminal is pointing to the Engine Board.
2. Slide the battery into the holder and apply slight pressure until it snaps into place.
3. If the unit has Sound ROM options, install them.
4. Install the seven screws to secure the access panel.

PC2R Rack Models

Accessing the Battery

1. Remove the seven screws that secure the top cover.
2. Slide the top cover back from the Front Panel Assembly to release the top cover from the bottom enclosure, and place the top cover safely aside to avoid damage.
3. If the unit has Sound ROM options installed, remove them.

Removing the Battery

The battery (CR2032) in the PC2 keyboard is mounted into a holder on the Engine Board and is accessible when the access panel is removed.

1. Refer to Figure 5-1. Insert a flat plastic tool (plastic knife, pen cap, etc.) into one of the openings between the battery and the holder to lift the battery.
2. Ease the battery out of the holder. If necessary, insert the plastic tool at the bottom of the holder (closest to the Engine Board) to remove the battery.

Installing the Battery

1. Position the battery over the holder so that the positive terminal is pointing to the Engine Board.
2. Slide the battery into the holder and apply slight pressure until it snaps into place.
3. If the unit has Sound ROM options, install them.
4. Place the top cover in position and slide it toward the Front Panel Assembly.
5. Install the seven screws that secure the top cover.

Scanner Tests

PC2R Rack Models

The Scanner Tests for the PC2R rack model include separate tests for the front panel buttons and LEDs, rotary potentiometers including Knobs A–D and Volume, and the Alpha Wheel.

To enter the Scanner Tests, first turn on the PC2R. Once the PC2R is on and ready to play, simultaneously hold down the three buttons located in the top row of the Modes section (**Internal Voices**, **KB3** and **MIDI Setups**). All front panel LEDs will light in a sequence and the LCD will display the following:

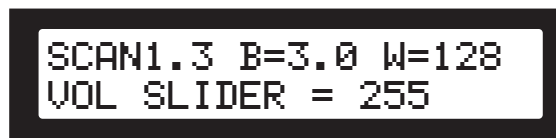

Figure 5-2 LCD example, PC2R scanner tests

The first line of the display shows the scanner software version, the battery voltage and the current value for the Mod Wheel position. Disregard the Mod Wheel value; it is applicable only to keyboard units. The second line shows the results of the current test. Figure 5-2 shows the result of the volume potentiometer test.

To exit the Scanner Tests and return to normal operation, simultaneously press the **Cancel** and **Enter** buttons.

Front Panel Buttons

To test a button, press any front panel button.

An example of the expected test result for the **Solo** button follows: **BUTTON Solo**

Alpha Wheel

To test the Alpha Wheel, turn it to increase or decrease the value by one. The expected test result when the **Alpha Wheel** is turned is one of four values—0, 1, 2, or 3:

SPINKNOB = 3

Front Panel Knobs

To test Knobs A–D or the Volume potentiometer, turn a knob to check its value at the bottom (zero, far left) and at the top (far right).

An example of the normal test results for the **Knob A** follows (your results may vary slightly):

At zero (far left): **SLIDER 1 = 0**

At top (far right): **SLIDER 1 = 255**

PC2 Keyboard Models

The Scanner Tests for the PC2 keyboard models include separate tests for the front panel buttons and LEDs, front panel sliders including the Master Volume slider, the Alpha Wheel, the Mod and Pitch wheels, the keyboard, and the pedals.

To enter the Scanner Tests, first turn on the PC2. Once the PC2 is on and ready to play, simultaneously hold down the 4, 5 and 6 buttons. All front panel LEDs will flash and the LCD will display the following:

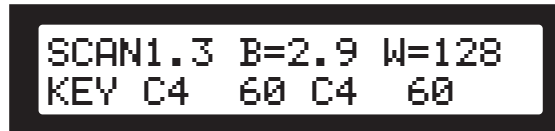

Figure 5-3 LCD example, PC2 scanner tests

The first line of the display shows the scanner software version, as well as the battery voltage and the current value for the Mod Wheel position. The second line shows the results of the current test. Figure 5-3 shows the result of a key test—in this case striking the key C4 on the keyboard.

To exit the Scanner Tests and return to normal operation, simultaneously press the **Cancel** and **Enter** buttons.

Front Panel Buttons

To test a button, press any front panel button. An example of the expected test result for the **Solo** button follows:

```
BUTTON Solo
```

Alpha Wheel

To test the Alpha Wheel, turn it to increase or decrease the value by one. The expected test result when the **Alpha Wheel** is turned is one of four values—0, 1, 2, or 3:

```
SPINKNOB = 3
```

Front Panel Sliders

To test the front panel sliders, move a slider to check its value at the bottom, center, and top. An example of the normal test results for the **Slider A** follows (your results may vary slightly):

```
At bottom: SLIDER 1 = 0
```

```
At center: SLIDER 1 = 128
```

```
At top: SLIDER 1 = 255
```

Wheels

To test the pitch and mod wheels, move the wheel up and down. An example of the expected test results for the pitch wheel follows (your results may vary slightly):

At bottom: PITCH WHEEL = 0

At center: PITCH WHEEL = 128

At top: PITCH WHEEL = 255

Keyboard

To test the keyboard, press any key. The key name and number will be displayed twice in the LCD. The first set of name and number is the test result for the front key contact switch and the second is for the rear switch. An example of the expected test result for the Middle C key follows:

KEY C4 60 C4 60

Pressing harder the display will change and show the pressure value.

PRESSURE = 255

Switch Pedals 1, 2, and 3

To test a switch pedal, press the pedal. An example of the expected test result for the switch pedal 1 follows:

Full depression: PEDAL 1

Continuous Pedals 1 and 2

To test the continuous control pedal, press the pedal. An example of the expected test result for the continuous control pedal follows:

No depression: CTRL PEDAL = 255

Full depression: CTRL PEDAL = 0

Power Problems

Dead

1. Before opening the unit, verify the following:
 - The AC outlet is supplying power.
 - The AC adapter is properly connected to the unit.
2. Check the power switch, power jack and AC adapter.
3. Refer to the Interconnect Diagram. See page 5-13 for rack models or page 5-14 for keyboard models. Check all related connections.
4. Refer to the Connector Board schematics and check all supply voltages.

Audio Problems

No Audio



Note: If you are diagnosing a PC2R rack unit, you can check for audio without having a controller connected. Connect a pair of headphones, turn the power on. When the unit is on and ready to play, simultaneously press the **MIDI Receive** and **Global** buttons to play one of the stored demos. Flashing LEDs in the Performance section indicate the locations of the stored demos. Select one to play to check the audio. Press the **Cancel** button to exit.

1. Run the Scanner Diagnostics to check the volume slider operation.
2. Refer to the Interconnect Diagram. See page 5-13 for rack models or page 5-14 for keyboard models.
3. Check the flat ribbon cable from J412 on the Engine Board to J302 on the Connector Board.
4. Check the solder connections at the connectors.
5. Refer to the Engine Board schematics and check the signal activity on the DAC, U23.
6. Trace the signal path.

Front Panel Problems

LCD not lit

1. Check the LCD contrast potentiometer. Turn the pot to see if there is any change.



Note: If you are servicing a PC2R rack unit, the LCD Contrast is located on the front panel. If you are servicing a PC2 keyboard, it is located on the rear panel.

2. Check the stranded wire cable from the LCD Board to J405 on the Engine Board. Disconnect and reseal the cable.
3. Check the flat ribbon cable from the LCD Board to J406 on the Engine Board. Disconnect and reseal the cable.
4. Check the solder connections on the LCD and Engine Boards.
5. Refer to the Engine Board schematics and check the signal path.

Buttons, Sliders or Controllers not working

1. Run the Scanner Tests.



Note: If you are servicing a PC2R rack unit, simultaneously press the **Internal Voices**, **KB3** and **MIDI Setups** buttons located in the top row of the Modes section. If you are servicing a PC2 keyboard, simultaneously press the **4**, **5** and **6** buttons.

2. Refer to the Interconnect Diagram. See page 5-13 for rack models or page 5-14 for keyboard models.
3. Check all related cables.
4. Disconnect and reseal the cables.
5. Check the solder connections at the connectors.
6. Check front panel ribbon cable(s).
7. Refer to the Connector Board schematics and check U1, IC Scanner 37451, for signal activity.

Keyboard Problems

Dead Keyboard

1. Check the flat ribbon cables connecting the keyboard Bass and Treble Contact Boards to the Connector Board, locations J306 and J307. Be certain that the cables are not loose or damaged.
2. Disconnect and reseal the cables.
3. Refer to the Connector Board schematics.
4. Check U1, IC Scanner 37451 on the Connector Board for keyboard signals.
5. Trace signal path.
6. Find and replace bad component(s) or order a board replacement.

Dead Note(s)

One or More in a Section

1. Remove related contact board.
2. Check contact strip for dirt, damage or wearing. Clean dirty contacts with denatured alcohol. Replace damaged or worn contact strip.
3. Install contact strip.
4. If section is still dead, remove strip and check contact board for shorts, cold solder joints, etc.
5. Find and replace bad component(s) or order replacement board.

Mechanical Noise

1. Check keyboard for broken key weights, support brackets, or ripped contacts.

PC2R Interconnect Diagram

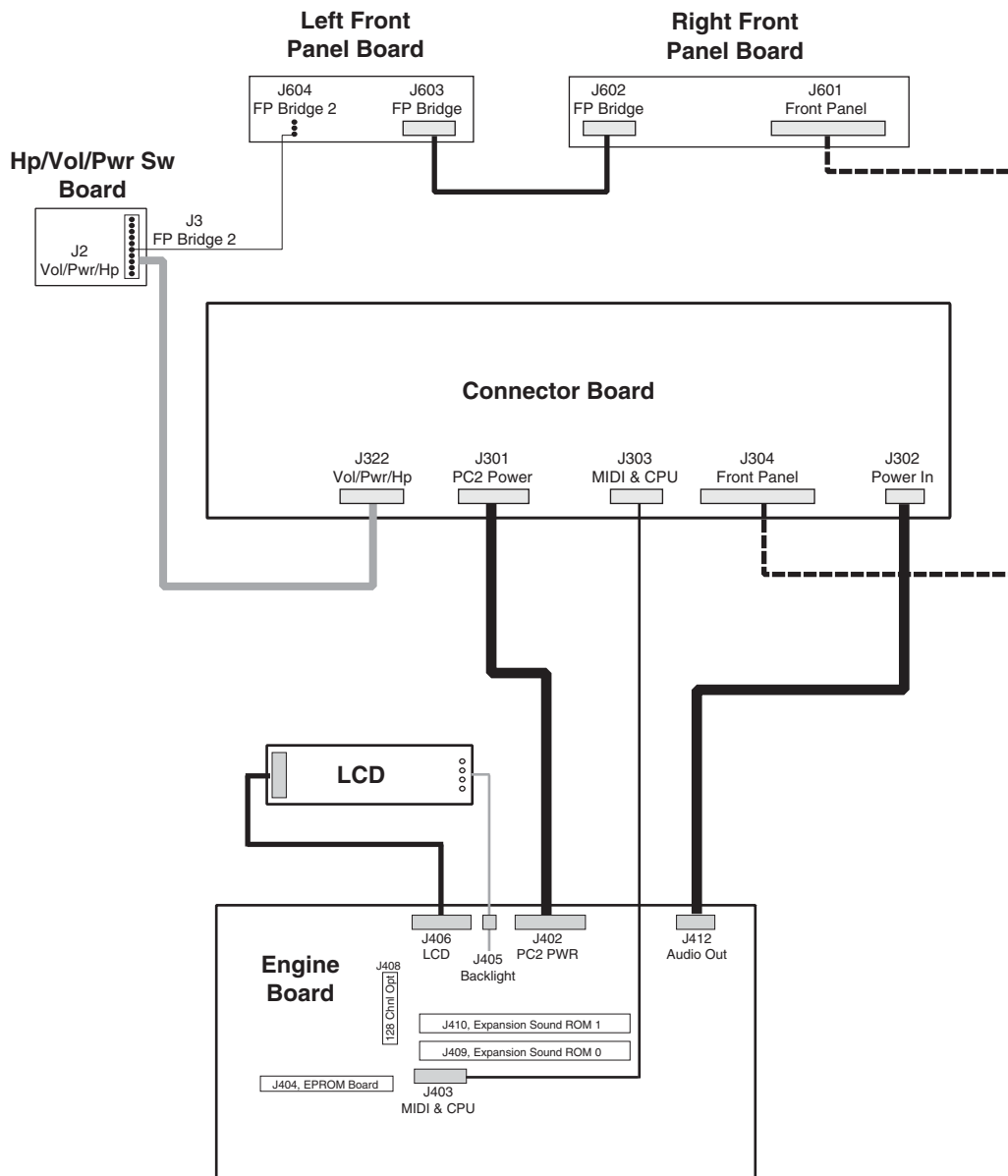

PC2 Interconnect Diagram

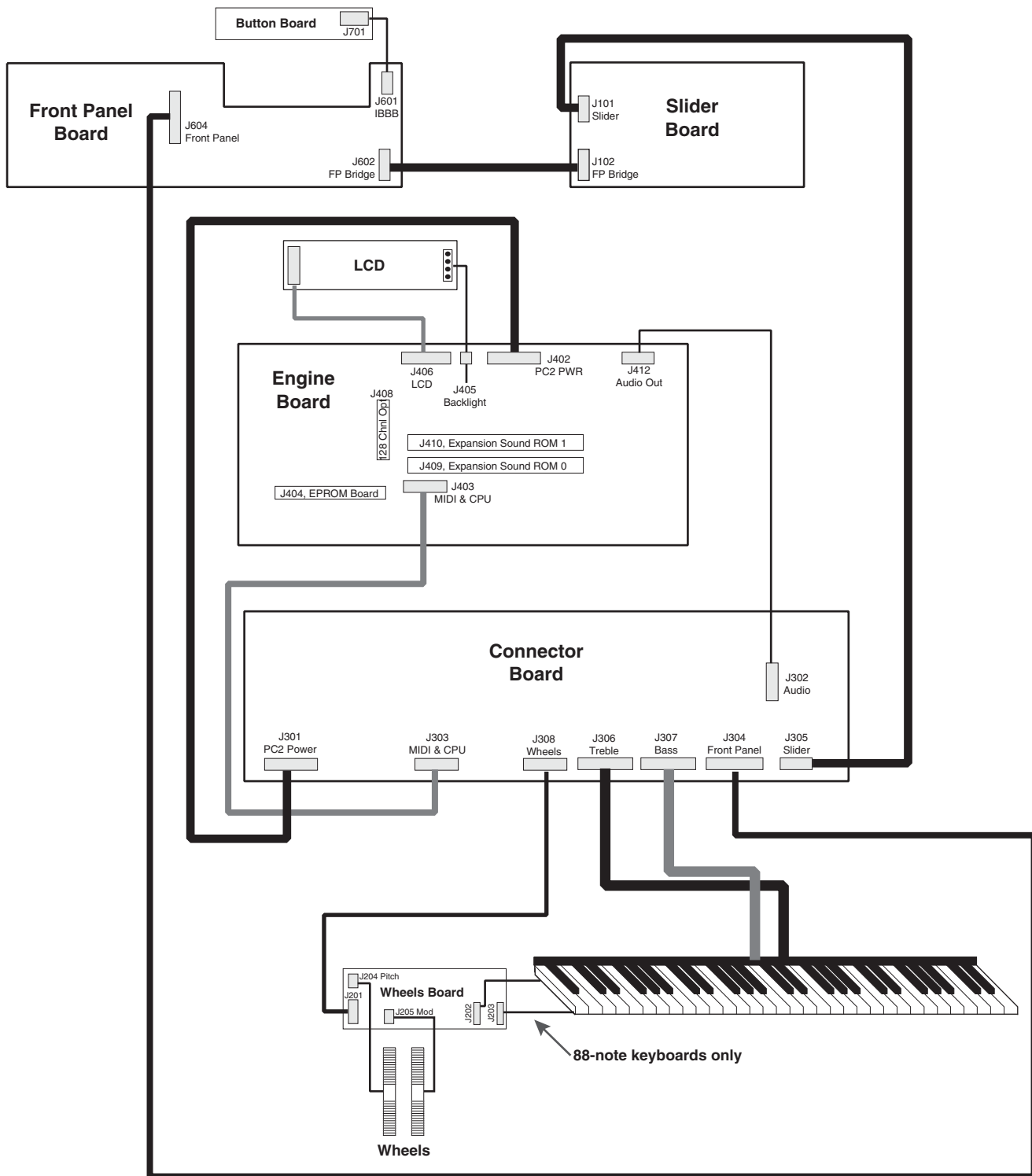

Chapter 6

Parts Lists

Introduction

The parts lists included in this chapter cover all models of the PC2 series. Some printed circuit boards and assemblies are used in more than one model. Therefore, the parts lists on the following pages are listed under these headings:

PC2R/PC2/PC2X	All Models
PC2/PC2X	Keyboard Models
PC2R	Rack Model

The following two tables list the printed circuit boards and assemblies by model.



Note: The PC2 and PC2X have been combined as these two models share most printed circuit boards and assemblies in common. The exceptions are the parts lists for the Final and Keyboard Assemblies.

PC2/PC2X Printed Circuit Boards and Assemblies

Part No.	Description	Page
N012000150	Final Assembly, PC2	page 6-9
N012000151	Final Assembly, PC2X	page 6-11
N012103800	LCD Board	page 6-8
N012300051	Engine Board	page 6-3
N012300053	Pitch & Mod Wheel Assembly	page 6-8
N012300061	Connector Board	page 6-6
N012400051	Slider Board	page 6-9
N012400052	Front Panel Board	page 6-5
N215040311	Keyboard TP-8R AFT 76 Note	page 6-10
N215040413	Keyboard TP-10MDF AFT 88 Note	page 6-12

PC2R Printed Circuit Boards and Assemblies

Part No.	Description	Page
N012000153	Final Assembly	page 6-16
N012103802	LCD Board	page 6-15
N012300040	Connector Board	page 6-13
N012300051	Engine Board	page 6-3
N012300070	Front Panel Assembly	page 6-14
N012300080	Left Front Panel Board	page 6-14
N012300090	Right Front Panel Board	page 6-15
N012700019	Headphone/Volume/Power Switch Board	page 6-15

PC2R/PC2/PC2X

Engine Board, N012300051

Part No.	Description	Qty.	Reference Designation
N035040201	BATTERY HOLDER TOSHIBA (BV-32) PC-88	1	J411
N041010401	SHUNTS JUMPER 2mm DIGI-KEY SPE1302-ND	1	@JP1
N041021264	SOCKET SIMM 22.5D TIN 64P LEFT METAL	2	J409, 410
N041025308	HEADER .156" SP 8P (09-65-2088)	1	J402
N041030040	HEADER 2mm SQR 3P R/A SAMTEC	1	JP1
N041030124	HEADER DUAL 2.0mm 24P MOLEX 87089-2416	1	J408
N041030150	HEADER DUAL 0.1" SQR 50POS DIGIKEY	1	J404
N041031210	CONN .1" SP DUAL ROW 14P (057-014-153)	1	J406
N041032305	CONN WIRE TRAP 2.00mmSP 5P (52147-0510)	1	J412
N041032310	CONN WIRE TRAP 2.00mmSP 10P (52147-1010)	1	J403
N041034002	HEADER .098" SP 2P (22-03-5025)	1	J405
N042005422	JUMPER WIRE 2.5MM	1	JP2 PINS 1 & 2
N051102103	RELAY 5V DPDT (G6H-2-DC5)	2	RY1-2
N064003502	IC LINEAR +5V LM78M05 500mA TO-220	1	VR1
N051064004	RES TF 47Ω 5% 1/16W 0603 T&R	4	R1, 26, 27, 39
N051064010	RES TF 100Ω 5% 1/16W 0603 T&R	1	R38
N051064011	RES TF 110Ω 5% 1/16W 0603 T&R	1	R28
N051064015	RES TF 1.5KΩ 5% 1/16W 0603	2	R64, 65
N051064025	RES TF 330Ω 5% 1/16W 0603	1	R32
N051064100	RES TF 1KΩ 5% 1/16W 0603 T&R	4	R5, 8, 34, 68
N051064109	RES TF 1MΩ 5% 1/16W 0603 T&R	2	R15, 16
N051064110	RES TF 10KΩ 5% 1/16W 0603 T&R	10	R7, 14, 17-18, 23-25, 29, 36-37
N051064130	RES TF 1.3KΩ 5% 1/16W 0603 T&R	1	R4
N051064220	RES TF 2.2KΩ 5% 1/16W 0603 T&	2	R6, 9
N051064470	RES TF 4.7KΩ 5% 1/16W 0603 T&R	3	R2, 10, 30
N051064472	RES TF 470Ω 5% 1/16W 0603	2	R31, 33
N051064820	RES TF 820Ω 5% 1/16W 0603	1	R3
N051066124	RES TF 1.24KΩ 1% 1/16W 0603	4	R60, 61, 66, 67
N051066453	RES TF 453Ω 1% 1/16W 0603	4	R56, 57, 62, 63
N051066464	RES TF 464Ω 1% 1/16W 0603	4	R48-51
N051066475	RES TF 475Ω 1% 1/16W 0603	4	R52-55
N051066487	RES TF 487Ω 1% 1/16W 0603	4	R40-43
N051066499	RES TF 499Ω 1% 1/16W 0603	4	R44-47
N051100010	RES NET QUAD ISO 10KΩ 5% 1/16W	11	RP1-4, 6-12
N051100047	RES NET QUAD ISO 47Ω 5% 1/16W	9	RP13-21
N051101701	RES TF 36Ω 5% 1/8W 1206	1	R35
N051101706	RES CF 47Ω 5% 1/8W 1206	1	R70
N051130082	RES TF 8.2Ω 5% 1/4W 1210	1	R13
N051130220	RES TF 220Ω 5% 1/4W 1210	2	R19, 21
N051130330	RES TF 330Ω 5% 1/4W 1210	2	R20, 22
N052007006	CAP CER NPO 6.8PF 50V 5% 1206	2	C11, 13

Parts Lists

PC2R/PC2/PC2X

Part No.	Description	Qty.	Reference Designation
N052007406	CAP CER N90 2200PF 50V 5% 1206	4	C71, 72, 75, 76
N052007503	CAP CER X7R 0.1UF 50V 10% 1206	46	C5, 615-38, 41-43, 47, 60-63, 69, 70, 73, 74, 77-81, 86, 87, 91
N052007809	CAP CER NPO 100PF 50V 5% 0603	1	C1
N052007833	CAP CER NPO 33PF 50V 5% 0603	4	C9, 10, 12, 14
N052080010	CAP CER NPO 1000PF 50V 5% 0805	2	C2, 7
N052900747	CAP ELE GP 47UF 35V SZE SMT	5	C48-51, 68
N052901610	CAP ELECT GP 10UF 16V 20% SZB SMT	8	C39, 44-46, 64-67
N052901622	CAP ELCCT GP 220UF 10V 20% SZE SMT	1	C3
N052902522	CAP ELECT GP 22UF 35V 20% SZD SMT	1	C40
N053000703	DIODE RECT GP SMT 1A S1A SMA 1N4001 1206	1	D5
N053000802	DIODE SWITCH 1N4148 SMT DL-35	2	D2, 3
N054000102	TRANSISTOR KST3904 SOT-23	1	Q1
N054000802	TRANSISTOR MMBT2222L SOT-23	1	Q2
N054002906	TRANSISTOR MMBT2907L SOT-23	2	Q3, 4
N055001505	IND FE BD 2.5-TURN SMT	2	L1, 2
N055001509	IND FE BD SMT 200mA 600Ω 100MHZ 0805	2	R11, 12
N059010060	XTL 20.0000MHz +/-50PPM FND PAR 18PF SMT	1	Y1
N059010061	XTL 24.576MHz +/-50PPM FND FAR 18PF SMT	1	Y2
N061000802	IC LOGIC FAIRCHILD (TI) SN74AHC1G08DBVR	3	U3, 4, 18
N061000912	IC LOGIC INV TINY UHS UNBUF SOT23-5	2	U12, 13
N061007139	IC LOGIC 74VHC139 SOP16	1	U10
N061007144	IC LOGIC 74VHC14 SOP14-150	1	U1
N061011008	IC LOGIC 74AC08 SOP14-150	2	U6, 14
N061011245	IC LOGIC 74HC245 SOP20	1	U8
N062004905	IC IF UART ST16C550 W/FIFO'S PLCC 44P	1	U22
N062004913	IC IF DAC AK4393VF DL 24B DS +5VS VSOP28	1	U23
N062005525	IC MEM FLSH ROM 1MX16 70nS SSOP56-525 5V	1	U5
N062005704	IC GAL 16V8A-15QJ SMT PLCC20	1	U21
N062100410	IC MEM SRAM 256kX16 55nS TSOP44-400 LO\ PWR	1	U7
N062100416	IC MEMORY DRAM 1MX16 70nS(max) SOJ42	2	U16, 17
N064003508	IC ANA OPAMP DL BIP LO-NOIS NE5532A	4	U24-27
N083016001	IC MASKROM PC2 BASE HI 830160-001	1	U19
N083016101	IC MASKROM PC2 BASE LO 830161-001	1	U20
N252007456	CAP CER NPO 5600PF 50V 5% 1206	8	C52-59
N253000702	DIODE SHTKY SIG 5NS LO-C SL BAS40 SOT-23	2	D1, 4
N262001301	IC MC 68331CPV25 MOTOROLA	1	U2
N266000412	IC CUSTOM MABEL-2	2	U9, 11
N266000801	IC LISA VY06514 PLCC84	1	U15
N035040105	BATTERY COINCELL 3V 195mah CR2032 TOSHIBA	1	

PC2/PC2X

Front Panel Board, N012400052

Part No.	Description	Qty.	Reference Designation
N032009401	FRONT PANEL PCB SUPPORT BRACKET PC-88	1	
N035026011	BUTTON SM W/LED (3GANG)	5	
N035026012	BUTTON SM W/LED RED PC2/X	1	
N035026101	BUTTON LG W/LED PC-88	13	
N035026141	BUTTON LG W/LED (1,2,3,4) PC2/X	1	
N035026142	BUTTON LG W/LED (5,6,7,8) PC2/X	1	
N035026143	BUTTON LG W/LED (9,10,11,12) PC2/X	1	
N035026144	BUTTON LG W/LED (13,14,15,16) PC2/X	1	
N035026145	BUTTON LG NO LED(3) (1,2,3) PC2/X	1	
N035026146	BUTTON LG NO LED(3) (4,5,6) PC2/X	1	
N035026147	BUTTON LG NO LED(3) (7,8,9) PC2/X	1	
N035026148	BUTTON LG NO LED(3) (+/-,0,CLEAR)	1	
N035026149	BUTTON LG NO LED(1) (CANCEL) PC2/X	1	
N035026150	BUTTON LG NO LED(1) (ENTER) PC2/X	1	
N035026151	BUTTON LG W/LED (SOLO) PC2/X	1	
N035026152	BUTTON LG W/LED (EQ) PC2/X	1	
N035026153	BUTTON LG W/LED (SW1) PC2/X	1	
N035026154	BUTTON LG W/LED (SW2) PC2/X	1	
N035026155	BUTTON LG W/LED (SW3) PC2/X	1	
N035026156	BUTTON LG W/LED (SW4) PC2/X	1	
N035026157	BUTTON LG W/LED (SW5) PC2/X	1	
N035026217	BUTTON LG NO LED	6	
N035026611	LCD SUPPORT BEZEL	1	
N035026711	SPIN KNOB BEZEL	1	
N041031220	HEADER .1" SP DUAL ROW 20P	1	J604
N041032205	CONN WIRE TRAP 2.00mmSP 5P R/A	1	J701
N041032305	CONN WIRE TRAP 2.00mmSP 5P R/A	1	J601
N041032308	CONN WIRE TRAP 2.00mmSP 8P	1	J602
N043003703	SWITCH TACT SPST 6mmX6mm 160GF	72	S1-72
N044010501	ENCODER 36 STEP 2BIT	1	SP1
N045010111	LED T1 RED HI EFF DIFFUSED LTL-422	49	D1-7, 9-12, 14-16, 20-24, 26-29, 32, 34-38, 40, 42-44, 48, 50-53, 55-60, 63, 66-69
N045010612	LED MINI GREEN DIFUSED T1	3	D33, 41, 49
N051005010	RES CF 1Ω 5% 1/8W	1	R8
N051100102	RES CF 15Ω 5% 1/8W	7	R1-7

Parts Lists

PC2/PC2X

Part No.	Description	Qty.	Reference Designation
N051100157	RES CF 10K Ω 5% 1/8W	18	R9-26
N052001204	CAP CER MONO Z5U .1UF 50V 20% .3AX	3	C2-4
N054000801	TRANSISTOR PN2222 TO-92	7	Q1-7
N054001201	TRANSISTOR PNP KTA1271(KSA643CY) TO-9	10	Q8-17
N061000301	IC LOGIC 74LS145 DIP16-300	1	U2
N061014001	IC LOGIC 74HC541 DIP20	1	U1
N061020501	IC LOGIC 74HC373 DIP20	1	U3
N252003102	CAP ELECT ECE-BOJU471 470UF 6.3V VERT AX	2	C1, 6

Connector Board, N012300061

Part No.	Description	Qty.	Reference Designation
	RES TF 7.5K Ω 5% 1/8W 1206	1	R19
N025224508	TAPPING SCREW-2 BH 3.5X8 WHITE W/WASHER	3	
N025323308	MACHINE SCREW BH M3X8 BLK	1	
N032038811	BRACKET SUPPORT I/O PCB PC2/X	1	
N032038816	BRACKET SUPPORT POWER JACK PC2/X	1	
N032064801	EXTRUSION HEAT TRANSFER	1	
N041006503	CONN PWR JACK 4P W/SHIELD UNITOP	1	J321
N041021903	JACK PHONE RCA TYPE TA PCMT	1	J300
N041025308	HEADER .156" SP 8P (09-65-2088)	1	J301
N041030033	MODULAR JACK 6P R/A AMP 555163-1	1	J316
N041030310	CONN MIDI JACK 3-GANG YKF 51-5041(JALCO)	1	J320
N041031220	HEADER .1" SP DUAL ROW 20P (057-020-153)	3	J304, 306, 307
N041032305	CONN WIRE TRAP 2.00mmSP 5P (52147-0510)	1	J302
N041032306	CONN WIRE TRAP 2.00mmSP 6P (52147-0610)	1	J308
N041032307	CONN WIRE TRAP 2.00mmSP 7P (52147-0710)	1	J305
N041032310	CONN WIRE TRAP 2.00mmSP 10P (52147-1010)	1	J303
N041034401	PHONE JACK MONO 1/4" RA49C-12A MONO	3	J317-319
N041034411	CONN STEREO 1/8" W/SWITCH UNITOP	1	J315
N041034501	PHONE JACK STEREO 1/4" RA49C-14B	5	J310-314
N043003702	SWITCH POWER DPDT NKK M2022TXW30-DA	1	S2
N043010510	SWITCH SLIDER R/A 2.5mmSP SPDT	1	S1
N051064005	RES TF 56 Ω 5% 1/16W 0603	4	R93, 96, 99, 102
N051064011	RES TF 110 Ω 5% 1/16W 0603	12	R17, 20, 65, 68, 69, 73-75, 94, 95, 97, 98
N051064015	RES TF 1.5K Ω 5% 1/16W 0603	1	R22
N051064022	RES TF 220 Ω 5% 1/16W 0603	4	R100, 101, 126, 128
N051064110	RES TF 10K Ω 5% 1/16W 0603	21	R1-3, 9, 10, 12-14, 24, 70, 77, 84-86, 108, 109, 121, 144, 146, 147, 149
N051064150	RES TF 150 Ω 5% 1/16W 0603	1	R81
N051064470	RES TF 470 Ω 5% 1/16W 0603	1	R118
N051100010	RES NET QUAD ISO 10K Ω 5% 1/16W 3.2mmX1.6mm	5	RP9-13
N051100011	RES NET QUAD ISO 100 Ω 5% 1/16W	8	RP1-8
N051101706	RES CF 47 Ω 5% 1/8W 1206	2	R134, 137
N051101708	RES TF 56 Ω 5% 1/8W 1206	2	R4, 5

Part No.	Description	Qty.	Reference Designation
N051101721	RES CF 270Ω 5% 1/8W 1206	2	R6, 83
N051101724	RES 470 5% 1/8W 1206	2	R18, 117
N051101730	RES CF 1.0KΩ 5% 1/8W 1206	3	R87, 120, 148
N051101734	RES TF 1.5KΩ 5% 1/8W 1206	1	R82
N051101738	RES CF 2.2KΩ 5% 1/8W 1206	2	R8, 66
N051101760	RES CF 20KΩ 5% 1/8W 1206	1	R80
N051101768	RES TF 680KΩ 5% 1/8W 1206	3	R76, 78, 79
N051101780	RES CF 100KΩ 5% 1/8W 1206	7	R7, 15, 88-91, 150
N051101783	RES TF 200KΩ 5% 1/8W 1206	1	R145
N051101790	RES CF 1.0MΩ 5% 1/8W 1206	5	R11, 16, 71, 72, 119
N051101794	RES CF 1.5MΩ 5% 1/8W 1206	1	R63
N051102302	POT R/A 10K 12RV03 (JUNG POONG)	1	R107
N051103073	RES CF 165KΩ 1% 1/8W 1206	1	R64
N051103121	RES TF 121KΩ 1% 1/8W 1206	1	R67
N051103151	RES TF 15.00KΩ 1% 1/8W 1206	8	R122, 123, 132, 133, 135, 136, 138, 142
N051120030	RES TF 3.0KΩ 5% 1/8W 1206	3	R106, 127, 129
N051125201	RES TF 200Ω 1% 1/4W 1210	4	R124, 130, 139, 141
N052001223	CAP CER MONO 0.22UF 50V 20% AX	1	C39
N052001712	CAP ELECT 1000UF 25V RAD	1	C30
N052002412	CAP ELECT 470UF 25V 20% .2SP	1	C31
N052007401	CAP CER NPO 100PF 50V 5% 1206	2	C46, 55
N052007503	CAP CER X7R 0.1UF 50V 10% 1206	21	C12, 13, 23, 24, 29, 32, 33, 35, 38, 41, 42, 44, 45, 48-54, 56
N052007810	CAP CER X7R 1000PF 50V 10% 0603	21	C1-3, 6, 8-11, 14-22, 25-27, 47
N052007833	CAP CER NPO 33PF 50V 5% 0603	2	C4, 5
N052901601	CAP ELECT GP 100UF 16V 20% SZC SMT	4	C28, 34, 36, 37
N052901602	CAP ELECT GP 0.197" SP RAD 1000UF 16V 20%	1	C40
N052901610	CAP ELECT GP 10UF 16V 20% SZB SMT	1	C7
N053000703	DIODE RECT GP SMT 1A S1A SMA 1N4001 1206	5	D12, 14, 15, 17, 22
N053000802	DIODE SWITCH 1N4148 SMT DL-35	14	D1-11, 13, 16, 21
N054000802	TRANSISTOR MMBT2222L SOT-23	4	Q2, 7, 9, 18
N054002906	TRANSISTOR MMBT2907L SOT-23	6	Q1, 3, 4, 8, 12, 13
N054010301	TRANSISTOR NPN KSC2331-Y	2	Q14, 15
N055001505	IND FE BD 2.5-TURN SMT	2	L3, 4
N055001509	IND FE BD SMT 200mA 600Ω 100MHz 0805	2	L1, 2
N059010010	XTL 12.2880MHz +/-50PPM FND PAR 18PF SMT	1	Y1
N061010302	IC LOGIC 74HCU04 SOP14	1	U5
N061014002	IC LOGIC 74HC4051 SOP16-200	1	U11
N061014003	IC LOGIC MC74HC541DW SOP-20	1	U2
N063002302	IC OPT COUPLER PC410	1	U7
N064001602	IC LINEAR OPAMP TL072 SOP8-160	1	U3
N064003508	IC ANA OPAMP DL BIP LO-NOIS NE5532A	1	U9
N064010031	IC COMPARATOR QUAD LM339 SOIC14/14W	1	U4
N064010804	IC LINEAR -12V LM79L12 SOP8	1	VR3
N064010805	IC LINEAR +5V KA78T05 5V 3A TO-220	1	VR1
N064010806	IC LINEAR +12V LM78M12 TO-220	1	VR2
N215000105	SCHOTT TRANSFORMER 67129600	1	L5
N262100608	IC MICROCONTROLLER M37451M8-731FP	1	U1

Parts Lists

PC2/PC2X

LCD Board, N012103800

Part No.	Description	Qty.	Reference Designation
N013040112	CABLE ENGINE TO LCD 14P RIBBON	1	
N013042601	CABLE ENGINE TO LCD BACKLIGHT 2P PC2/X	1	
N045010302	LCD UC-20212BLANO SAMSUNG PC-88/MX	1	

Pitch & Mod Wheel Assembly, N012300053

Part No.	Description	Qty.	Reference Designation
N013040122	CABLE POT TO WHEEL BD 3P #26 AWG 4	2	
N041030007	HEADER 0.1" SP 4P (22-03-2041)	2	J202, 203
N041032306	CONN WIRE TRAP 2.00mmSP 6P (52147-0610)	1	J201
N051100118	RES CF 220Ω 5% 1/8W	2	R18, 19
N051100132	RES CF 1KΩ 5% 1/8W	1	R17
N051100310	RES MF 1KΩ 1% 1/8W	1	R12
N051100316	RES MF 1.5KΩ 1% 1/8W	1	R13
N051100336	RES MF 4.99KΩ 1% 1/8W	2	R16, 20
N051100354	RES MF 10KΩ 1% 1/8W	2	R9, 10
N051100379	RES 110K 1/8W 1%	2	R6, 7
N051100439	RES MF 30.1KΩ 1% 1/8W	3	R4, 5, 8
N051100850	RES MF 2.49KΩ 1% 1/8W	1	R11
N051101401	RES POT 100K 3/4 TURN	2	R14, 15
N051101410	RES TRIMPOT 50K 3/4 TURN	1	R3
N051102301	POT ROTARY 10K (K2000)	2	R1, 2
N052001204	CAP CER MONO Z5U .1UF 50V 20% .3AX	6	C1-6
N064001903	IC LINEAR OPAMP TLC2272CP DIP8	3	U1-3
N025223410	TAPPING SCREW-2 BH 3X10 BLK	1	
N025224414	TAPPING SCREW-2 BH 3X14 BLK	2	
N031053800	BRACKET MOUNTING PITCH & MOD WHEEL PC2	1	
N032021811	BUSHING 8.0X26 K2000	1	
N032021911	SPRING TORSION MUSIC WIRE	1	
N035020311	PITCH & MOD WHEEL 35	2	
N035027013	PITCH & MOD WHEEL CHEEK	1	

Slider Board, N012400051

Part No.	Description	Qty.	Reference Designation
N035026158	BUTTON LG W/LED (ZONE1,3,4) PC2	4	
N035026321	SLIDER KNOB PC-88	5	
N035026411	SLIDER BEZEL PC-88	5	
N039000701	SLIDE VOLUME FELT 0.3TX12X70	5	
N041032307	CONN WIRE TRAP 2.00mmSP 7P (52147-0710)	1	J101
N041032308	CONN WIRE TRAP 2.00mmSP 8P (52147-0810)	1	J102
N043003703	SW TACT SPST 6mmX6mm 160GF ALPS SKHWAC	4	S1-4
N045010610	LED MINI RED/GREEN DIFUSSED T1 DKL-30RGM	4	D1-4
N051101502	SLIDER VOLUME SINGLE 10KB-LIN 45mm	5	R1-5
N053000801	DIODE 1N4148 DO-35	4	D5-8

PC2

Final Assembly, N012000150

Part No.	Description	Qty.	Reference Designation
E207407181	DOUBLE SIDE TAPE 3M (5MMX50M) #467	0.01	
N013030951	CABLE TIE	13	
N013041601	CABLE SLIDER TO FRONT PANEL 8P PC2/X	1	
N013041701	CABLE SLIDER TO CONN BD 7P PC2/X	1	
N013041801	CABLE ENGINE TO CONN BD 10P PC2/X	1	
N013041901	CABLE ENGINE TO CONN BD 5P PC2/X	1	
N013042001	CABLE WHEEL TO CONN BD 6P PC2/X	1	
N013042101	CABLE BUTTON BD TO FRONT PANEL 5P PC2/X	1	
N013042201	CABLE ENGINE TO CONN BD POWER PC2/X	1	
N013042301	CABLE KEYBOARD BASS & TREBLE PC2/X	1	
N013042302	CABLE KEYBOARD BASS PC2	1	
N013042401	CABLE FRONT PANEL TO CONN BD PC2/X	1	
N015048232	FELT 2TX20X1200 BLK KEYBOARD K2500/S	1	
N022002703	SPACER PUSH LOCKING 8.0MM TALL	4	
N022003714	CABLE CLAMP 14P	1	
N022003720	CABLE CLAMP 20P	4	
N025153512	TAPPING SCREW-1 TH 3.5X12 BLK	8	
N025153520	TAPPING SCREW-1 TH 3.5X20 BLK	16	
N025224508	TAPPING SCREW-2 BH 3.5X8 WHITE W/WASHER	35	
N025323408	MACHINE SCREW BH M4X8 BLK	35	
N025323410	MACHINE SCREW BH M4X10 BLK	4	
N025323414	MACHINE SCREW BH 4X14 BLK	2	
N025328310	MACHINE SCREW BH 3X10 BLK W/WASHER	4	
N032033632	BOTTOM PC2	1	
N032037732	LEFT SUPPORT WALL PC2/X	1	
N032037822	RIGHT SUPPORT WALL PC2/X	1	

Parts Lists

PC2

Part No.	Description	Qty.	Reference Designation
N032038813	CLAMP PCB PC2/X	5	
N032038814	BRACKET CLAMPING ENCLOSURE TOP PC2/X	2	
N032038815	BRACKET LOCKING ENDCAP PC2/X	2	
N032038950	SPACER (BLK)	2	
N032059011	PLATE COVER PCB PC2/X	1	
N035020711	KNOB ENCODER 52	1	
N035026511	LCD DISPLAY LENS PC-88	1	
N039004322	CABLE MOUNT BASE (DAMD-10)	9	
N125223408	TAPPING SCREW-2 BH 3X8 BLK (PLASTIC)	4	
N125223410	TAPPING SCREW-2 BH 3X10 AN (PLASTIC)	2	
N032033521	TOP COVER PC2	1	
N039040004	BUMPON 3M	4	
N052001022	ADAPTER	1	
N035027013	CHECK PITCH & MOD WHEEL	1	
N032033713	ENDCAP LEFT	1	
N032033813	ENDCAP RIGHT	1	
N125223408	TAPPING SCREW-2 BH 3X8 BLK (PLASTIC)	14	FOR ENDCAPS
N215040311	KEYBOARD TP-8R AFT STRIP 76 NOTE	1	

Keyboard Assembly, N215040311

Part No.	Description	Qty.	Reference Designation
	PCB KEY CONTACT LOW		
	PCB KEY CONTACT HIGH		
	KEY CONTACT STRIP (12 NOTE)		
	BRACKET ROD/KEY WEIGHT SUPPORT 12 PO		
	KEY PIVOT		
	BRACKET ROD/KEY WEIGHT SUPPORT 4 POS		
	KEY NATURAL A		
	KEY NATURAL B		
	KEY NATURAL C		
	KEY NATURAL D		
	KEY NATURAL E		
	KEY NATURAL F		
	KEY NATURAL G		
	KEY NATURAL LOW A		
	KEY NATURAL HIGH C		
	KEY SHARP		
	KEY WEIGHT NATURAL		
	KEY WEIGHT SHARP		
	FELT RED		
	AFTER TOUCH STRIP		

PC2X

Final Assembly N012000151

Part No.	Description	Qty.	Reference Designation
E207407181	DOUBLE SIDE TAPE 3M(5MMX50M)#4670.01		
N013030951	CABLE TIE	13	
N013041601	CABLE SLIDER TO FRONT PANEL 8P PC2/X	1	
N013041701	CABLE SLIDER TO CONNECTOR BD 7P PC2/X	1	
N013041801	CABLE ENGINE TO CONNECTOR BD 10P PC2/X	1	
N013041901	CABLE ENGINE TO CONNECTOR BD 5P PC2/X	1	
N013042001	CABLE WHEEL TO CONNECTOR BD 6P PC2/X	1	
N013042101	CABLE BUTTON BD TO FRONT PANEL 5P PC2/X	1	
N013042201	CABLE ENGINE TO CONN BD POWER PC2/X	1	
N013042301	CABLE KEYBOARD BASS & TREBLE PC2/X	1	
N013042303	CABLE KEYBOARD BASS PC2X	1	
N013042401	CABLE FRONT PANEL TO CONNECTOR B/D PC2/X	1	
N015047014	FELT (W/ ONE SIDE ADHESIVE) 1TX10X1000 BLK	2	
N015048236	FELT 2TX17X1300 BLK KRYBOARD K2500X/XS/AES	1	
N022002703	SPACER PUSH LOCKING 8.0MM TALL	4	
N022003714	CABLE CLAMP 14P	1	
N022003720	CABLE CLAMP 20P	4	
N025224508	TAPPING SCREW-2 BH 3.5X8 WHITE W/WASHER	35	
N025226508	TAPPING SCREW-2 BH 3.5X8 BLK W/WASHER	2	
N025323312	MACHINE SCREW BH 3X12 BLK	1	
N025323408	MACHINE SCREW BH M4X8 BLK	35	
N025323410	MACHINE SCREW BH M4X10 BLK	4	
N025323414	MACHINE SCREW BH 4X14 BLK	2	
N025328310	MACHINE SCREW BH 3X10 BLK W/WASHER	4	
N025328610	MACHINE SCREW BH 4X10 W/SFWASHER BLK	8	
N032033633	BOTTOM PC2X	1	
N032037732	LEFT SUPPORT WALL PC2/X	1	
N032037822	RIGHT SUPPORT WALL PC2/X	1	
N032038813	CLAMP PCB PC2/X	5	
N032038814	BRACKET CLAMPING ENCLOSURE TOP PC2/X	2	
N032038815	BRACKET LOCKING ENDCAP PC2/X	2	
N032038950	SPACER (BLK)	2	
N032059011	PLATE COVER PCB PC2/X	1	
N035020711	KNOB ENCODER	1	
N035026511	LCD DISPLAY LENS PC-88	1	
N039004322	CABLE MOUNT BASE (DAMD-10)	9	
N125223408	TAPPING SCREW-2 BH 3X8 BLK (PLASTIC)	4	
N032033522	TOP COVER PC2X	1	

Parts Lists

PC2X

Part No.	Description	Qty.	Reference Designation
N039040004	BUMPON 3M	4	
N052001022	ADAPTER	1	
N035027013	CHECK PITCH & MOD WHEEL	1	
N032033713	ENDCAP LEFT	1	
N032033813	ENDCAP RIGHT	1	
N125223408	TAPPING SCREW-2 BH 3X8 BLK (PLASTIC)	14	FOR ENDCAPS
N125223410	TAPPING SCREW-2 BH 3X10 AN (PLASTIC)	2	
N215040413	KEYBOARD TP-10MDF AFT (ABS)	1	

Keyboard Assembly, N215040413

Part No.	Description	Qty.	Reference Designation
	PCB KEY CONTACT LOW		
	PCB KEY CONTACT HIGH		
	KEY CONTACT STRIP (12 NOTE)		
	BRACKET ROD/KEY WEIGHT SUPPORT 12 POS		
	KEY PIVOT		
	BRACKET ROD/KEY WEIGHT SUPPORT 4 POS		
	KEY NATURAL A		
	KEY NATURAL B		
	KEY NATURAL C		
	KEY NATURAL D		
	KEY NATURAL E		
	KEY NATURAL F		
	KEY NATURAL G		
	KEY NATURAL LOW A		
	KEY NATURAL HIGH C		
	KEY SHARP		
	KEY WEIGHT NATURAL		
	KEY WEIGHT SHARP		
	FELT RED		
	AFTER TOUCH STRIP		

PC2R

Connector Board, N01230004

Part No.	Description	Qty.	Reference Designation
	RES TF 7.5K Ω 5% 1/8W 1206	1	R19
N041006503	CONN PWR JACK 4P W/SHIELD UNITOP	1	J321
N041021903	JACK PHONE RCA TYPE TA PCMT	1	J300
N041025308	HEADER .156" SP 8P (09-65-2088)	1	J301
N041030326	HEADER .1" SP DUAL ROW 26P (057-026-153)	1	J304
N041031104	JACK 1/4" STEREO (EPJ-BBB-P) BELTON	2	J311-312
N041032305	CONN WIRE TRAP 2.00mm SP 5P (52147-0510)	1	J302
N041032310	CONN WIRE TRAP 2.00mmSP 10P (52147-1010)	1	J303
N041034010	HEADER .098" SP 10P (22-03-5105)	1	J322
N041034031	CONN MIDI TRIPLE R/A PCMT (YKF51-5046)	1	J320
N043010510	SWITCH SLIDER R/A 2.5mmSP SPDT	1	S1
N051064005	RES TF 56 Ω 5% 1/16W 0603 T&R	4	R93, 96, 99, 102
N051064011	RES TF 110 Ω 5% 1/16W 0603 T&R	6	R17, 20, 94-95, 97-98
N051064016	RES TF 1.6K Ω 5% 1/16W 0603	1	R118
N051064022	RES TF 220 Ω 5% 1/16W 0603	2	R100-101
N051064110	RES TF 10 Ω 5% 1/16W 0603 T&R	13	R1-3, 12, 14, 24, 108-109, 121, 126, 128, 144, 147
N051100010	RES NET QUAD ISO 10K Ω 5% 1/16W	4	RP9-12
N051100011	RES NET QUAD ISO 100 Ω 5% 1/16W	3	RP6-8
N051101706	RES CF 47 Ω 5% 1/8W 1206	2	R134, 137
N051101708	RES CF 56 Ω 5% 1/8W 1206	2	R4-5
N051101721	RES CF 270 Ω 5% 1/8W 1206	1	R6
N051101724	RES 470 5% THICK FILM 1206	2	R18, 117
N051101730	RES CF 1.0K Ω 5% 1/8W 1206	2	R120, 148
N051101734	RES TF 1.5K Ω 5% 1/8W 1206	1	R22
N051101780	RES CF 100K Ω 5% 1/8W 1206	1	R15
N051101790	RES CF 1.0M Ω 5% 1/8W 1206	3	R11, 16, 119
N051102103	RELAY 5V DPDT (G6H-2-DC5)	1	RY1
N051103151	RES TF 15.00K Ω 1% 1/8W 1206	8	R122-123, 132-133, 135-136, 138, 142
N051120030	RES TF 3.0K Ω 5% 1/8W 1206	3	R106, 127, 129
N051120056	RES TF 5.6K Ω 5% 1/8W 1206	1	R8
N051125201	RES TF 200 Ω 5% 1/4W 1210	4	R124, 130, 139, 141
N052001204	CAP CER MONO Z5U 0.1UF 50V 20% 3AX	3	C1-3
N052001223	CAP CER MONO 0.22UF 50V 20% AX	1	C39
N052001711	CAP ELECT 100UF 25V 20% RAD	4	C28, 34, 36, 37
N052001712	CAP ELECT 1000UF 25V RAD	1	C30
N052002412	CAP ELECT 470UF 25V 20% .2SP	1	C31
N052007401	CAP CER NPO 100PF 50V 5% 1206	2	C46, 55
N052007503	CAP CER X7R 0.1UF 50V 10% 1206	16	C29, 32-33, 35, 38, 41-42, 44-45, 49-54, 56
N052007810	CAP CER X7R 1000PF 50V 10% 0603	10	C17-22, 25-27, 47
N052007833	CAP CER NPO 33PF 50V 5% 0603	2	C4-5
N052901602	CAP ELECT GP 0.197" SP RAD 1000UF 16V 20%	1	C40

Parts Lists

PC2R

Part No.	Description	Qty.	Reference Designation
N053000703	DIODE RECT GP SMT 1A S1A SMA 1N4001 1206	4	D14-15, 17, 22
N053000802	DIODE SWITCH 1N4148 SMT DL-35	2	D13, 21
N054000802	TRANSISTOR MMBT2222L SOT-23	3	Q7, 9, 18
N054002906	TRANSISTOR MMBT2907L SOT-23	4	Q4, 8, 12-13
N054010301	TRANSISTOR NPN KSC2331-Y	2	Q14-15
N055001505	IND FE BD 2.5 TURN SMT	4	L1-4
N059010010	XTL 12.2880MHz +/-50PPM FND PAR 18PF SMT	1	Y1
N061010302	IC LOGIC 74HCU04 SOP14	1	U5
N061014002	IC LOGIC 74HC4051 SOP16-200	1	U11
N063002302	IC OPT COUPLER PC410 SOP6-170	1	U7
N064003508	IC ANA OPAMP DL BIP LO-NOIS NE5532A	1	U9
N064010804	IC LINEAR -12V LM79L12 SOP8	1	VR3
N064010805	IC LINEAR +5V KA78T05 5V 3A TO-220	1	VR1
N064010806	IC LINEAR +12V LM78M12 TO-220	1	VR2
N215000105	SCHOTT TRANSFORMER 67129600	1	L5
N262100608	IC MICROCONTROLLER M37451M8-731FP	1	U1

Front Panel Assembly, N012300070

Part No.	Description	Qty.	Reference Designation
N025323306	MACHINE SCREW BH 3X6 BLK	7	BRACKET CLAMPING PCB & FRONT LEFT & RIGHT
N025383306	MACHINE SCREW FH M3X6 (SMALL)	4	FRONT PANEL & BRACKET CLAMPING PCB
N031063100	BRACKET CLAMPING PCB PC2R	1	
N035033900	LCD DISPLAY LEN PC2R	1	
N032027426	FRONT PANEL PC2R	1	

Left Front Panel Board, N012300080

Part No.	Description	Qty.	Reference Designation
N013035412	CABLE FRONT PANEL PC2R 200mm	1	
N041030036	HEADER 16P PICO FLEX MOLEX 90325-0016	1	J603
N041034002	HEADER .098" SP 2P (22-03-5025)	1	J604
N043003704	SW TACT SPST 6mmX6mm 160gf ALPS SKHHDA	6	S15-20
N045010111	LED T1 RED HI EFF DIFFUSED LTL-4221	1	D10
N045010610	LED MINI RED/GREEN DIFUSED T1 DKL-30RGM	5	D11, 13, 15, 17, 19
N035033800	KEYCAP W/LED PC2R	6	@15-20
N051102304	POT 10K 15mmLx6mmD FLAT ELEC	4	R19-22
N035025813	POWER SWITCH VOLUME KNOB PC2R	4	@R19-22
N051101702	RES CF 15Ω 5% 1/8W 1206	2	R17, 18
N052007503	CAP CER X7R 0.1UF 50V 10% 1206	1	C7
N053000802	DIODE SWITCH 1N4148 SMT DL-35	4	D12, 14, 16, 18
N054000802	TRANSISTOR MMBT2222L SOT-23	2	Q9-10

Right Front Panel Board, N012300090

Part No.	Description	Qty.	Reference Designation
N041030036	HEADER 16P PICOFLEX MOLEX 90325-0016	1	J602
N041030326	HEADER .1" SP DUAL ROW 26P (057-026-153)	1	J601
N043003704	SW TACT SPST 6mmX6mm 160gf ALPS SKHHDA	14	S1-14
N045010111	LED T1 RED HI EFF DIFFUSED LTL-4221	8	D1-8
N045010610	LED MINI RED/GREEN DIFUSED T1 DKL-30RGM	1	D9
N051004710	POT 36STEP 2BIT GRAY	1	SP1
N051102303	POT 10K 20mmLX6mmD KNURLED ELEC	1	R1
N052002422	CAP ELECT 470UF 6.3V 3.5mm SP.11mm	2	C1-2
N035033800	KEYCAP W/LED PC2R	9	@S3-8, 10, 11, 12
N035033600	KEYCAP NO LED PC2R	5	@S1, 2, 9, 13, 14
N035034000	KNOB ENCODER PC2R	1	@SP1
N051101702	RES CF 15Ω 5% 1/8W 1206	2	R9, 10
N051101703	RES CF 1Ω 5% 1/8W 1206	1	R2
N051101757	RES CF 10KΩ 5% 1/8W 1206	12	R3-8, 11-16
N052007503	CAP CER X7R 0.1UF 50V 10% 1206	7	C3-6, 8-10
N054000802	TRANSISTOR MMBT2222L SOT-23	2	Q1, 2
N054002906	TRANSISTOR MMBT2907L SOT-23	6	Q3-8
N061000302	IC LOGIC 74LS145 SOP16	1	U1
N061014003	IC LOGIC MC74HC541DW SOP-20	1	U3
N061020502	IC 74HC373A OCTAL LATCH SOIC20	1	U2

Headphone/Volume/Power Switch Board, N012700019

Part No.	Description	Qty.	Reference Designation
N041021007	HEADPHONE JACK (HTJ-064-05) MARK-XXX	1	J1
N041034110	HEADER 10P 1 ROW .098" SP R/A	1	J2
N251102305	POT 10K LIN PUSH SW PC2R	1	R1

LCD Board, N012103802

Part No.	Description	Qty.	Reference Designation
N013042502	CABLE ENG TO LCD 14P PC2R 330mm	1	
N013042603	CABLE ENG TO LCD BACKLIGHT 2P PC2R	1	
N245010320	LCD DISPLAY 20X2 Tinama (TM202JFF6)	1	

Parts Lists

PC2R

Final Assembly, N012000153

Part No.	Description	Qty.	Reference Designation
N013041802	CABLE ENG TO CONN BD 10P PC2R 160mm	1	
N013042202	CABLE ENG TO CONN BD POWER PC2R 200mm	1	
N032062700	FRONT PANEL	1	
N039040001	BUMPON (BLACK) 3M SJ-5508	4	
N052001021	ADAPTER (YCA) PC2	1	
N013042801	CABLE CONN TO HEADPHONE PC2R 270mm	1	
N013042901	CABLE CONN TO FRONT PANEL 26P PC2R 320mm	1	
N013043001	CABLE CONN TO ENG AUDIO 5P PC2R 105mm	1	
N022002703	BUTTON SUPPORT DONG-A DABS 8R	4	
N025223306	TAPPING SCREW-2 BH 3X6 BLK	13	
N025224508	TAPPING SCREW-2 BH 3.5X8 WHITE W/WASHER	1	
N025323306	MACHINE SCREW BH 3X6 BLK	7	
N025383306	MACHINE SCREW FH M3X6 (SMALL)	4	
N032062301	ENCLOSURE BOTTOM PC2R	1	
N032062500	ENCLOSURE TOP PC2R	1	
N032064900	HEAT SINK PC2R	1	
N125223408	TAPPING SCREW-2 BH 3X8 BLK (PLASTIC)	2	
N039020700	PRESSURE STRIP BOTTOM EDGE PCB PC2R	1	

Chapter 7

Schematics

Description	Page No.
Engine Board–Microprocessor (page 1 of 5)	page 7-3
Engine Board–Master/Slave Mabels (page 2 of 5)	page 7-4
Engine Board–Lisa F/X 128Ch Option, Clocks (page 3 of 5)	page 7-5
Engine Board–Sound ROM, Uart, Glue, Decoupling (page 4 of 5)	page 7-6
Engine Board–Audio Channel, Muting Control (page 5 of 5)	page 7-7
Front Panel and IBBB Board (keyboard models)–FP Buttons and LEDs (page 1 of 2)	page 7-8
Front Panel and IBBB Board (keyboard models)–IBBB Buttons and LEDs (page 2 of 2)	page 7-9
Connector Board (keyboard models)–Scanner (page 1 of 3)	page 7-10
Connector Board (keyboard models)–Digital Interface (page 2 of 3)	page 7-11
Connector Board (keyboard models)–Power Supply/Audio (page 3 of 3)	page 7-12
Slider Board (keyboard models)–Sliders	page 7-13
Right Front Panel Board (rack models)–FP Buttons and LEDs (page 1 of 2)	page 7-14
Left Front Panel Board (rack models)–Controllers, FP Buttons and LEDs (page 2 of 2)	page 7-15
Connector Board (rack models)–Scanner (page 1 of 3)	page 7-16
Connector Board (rack models)–Digital Interface (page 2 of 3)	page 7-17
Connector Board (rack models)–Power Supply/Audio (page 3 of 3)	page 7-18
Power/Volume/Headphone Board (rack models)	page 7-19

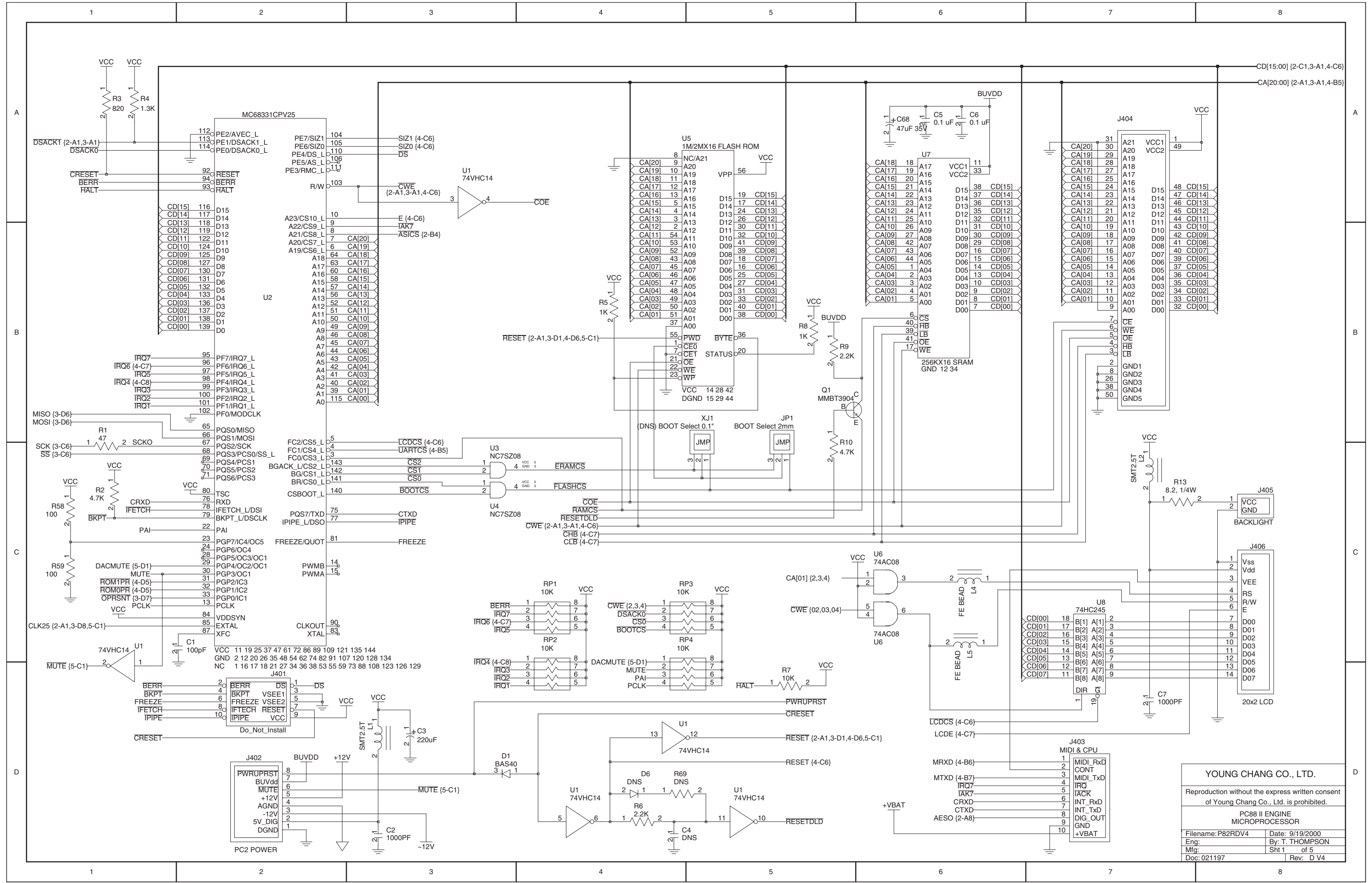

YOUNG CHANG CO., LTD.
 Reproduction without the express written consent
 of Young Chang Co., Ltd. is prohibited.
**PC88 II ENGINE
 MICROPROCESSOR**
 Filename: P82RDV4 Date: 9/19/2000
 Eng: By: T. THOMPSON
 Mfg: Sht 1 of 5
 Doc: 021197 Rev: D V4

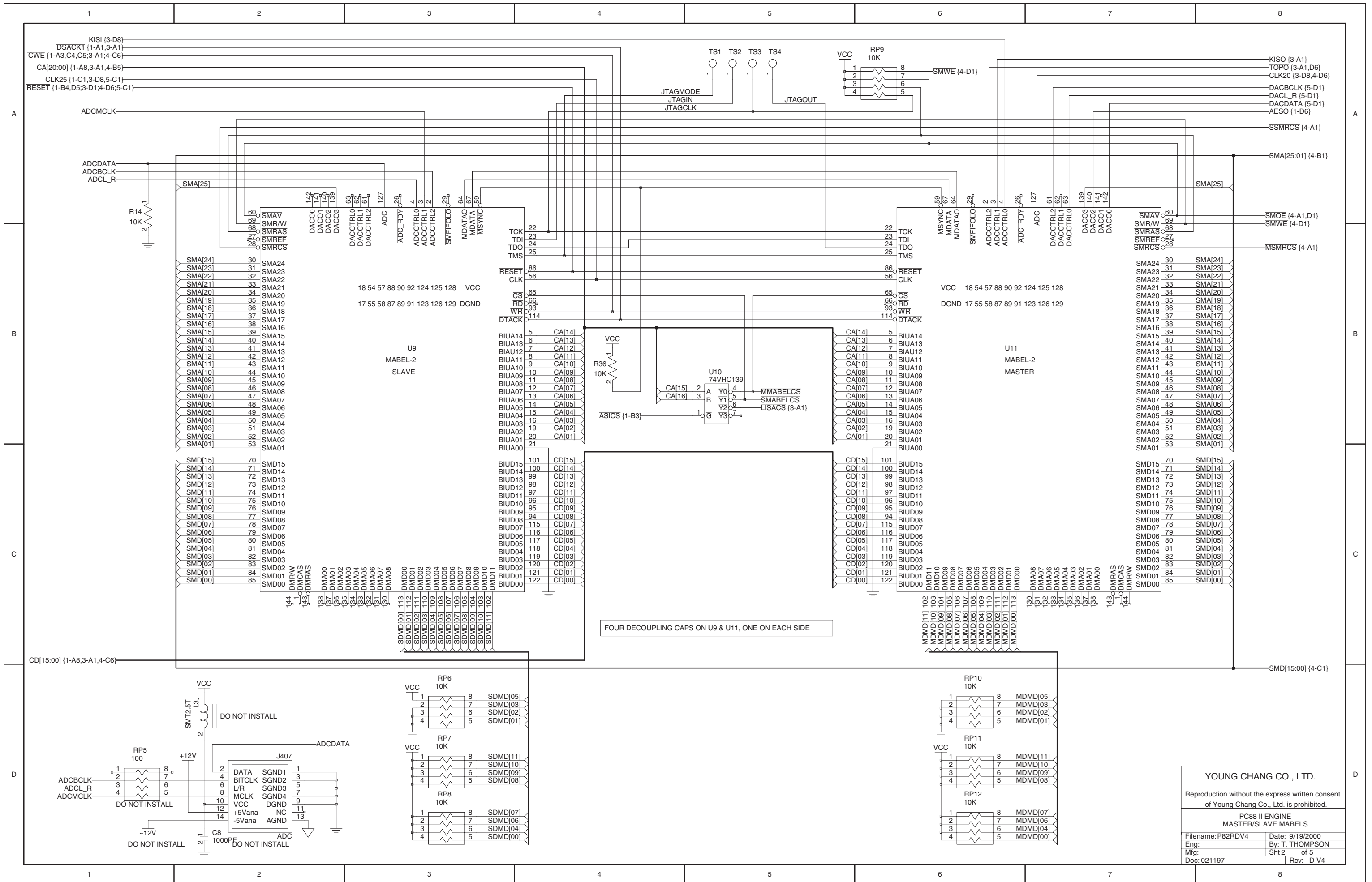

YOUNG CHANG CO., LTD.
 Reproduction without the express written consent of Young Chang Co., Ltd. is prohibited.
 PC88 II ENGINE MASTER/SLAVE LABELS
 Filename: P82RDV4 Date: 9/19/2000
 Eng: By: T. THOMPSON
 Mfg: Sht 2 of 5
 Doc: 021197 Rev: D V4

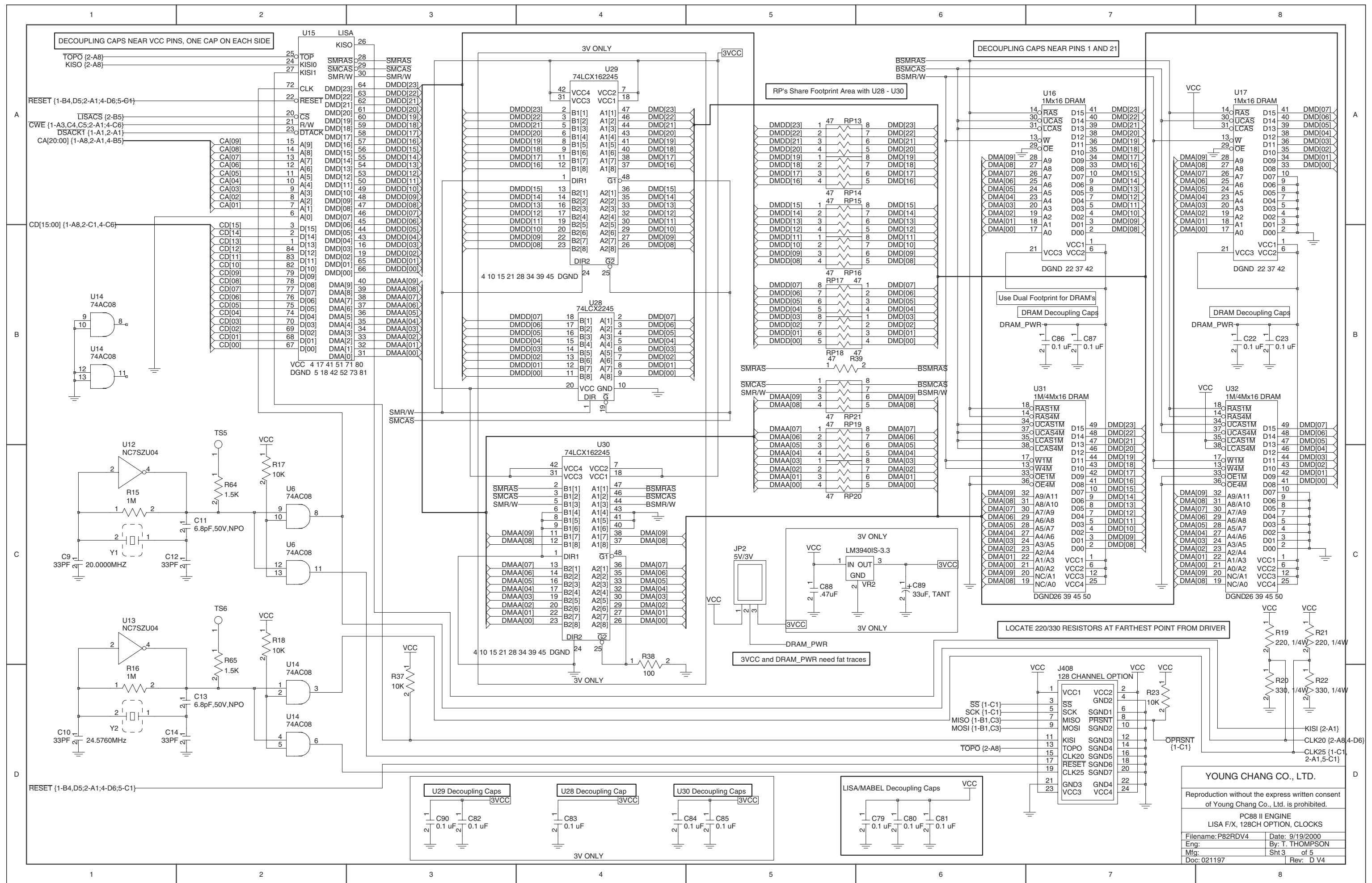

YOUNG CHANG CO., LTD.
 Reproduction without the express written consent of Young Chang Co., Ltd. is prohibited.
 PC88 II ENGINE
 LISA FX, 128CH OPTION, CLOCKS
 Filename: P82RDV4 Date: 9/19/2000
 Eng: By: T. THOMPSON
 Mfg: Sht 3 of 5
 Doc: 021197 Rev: D V4

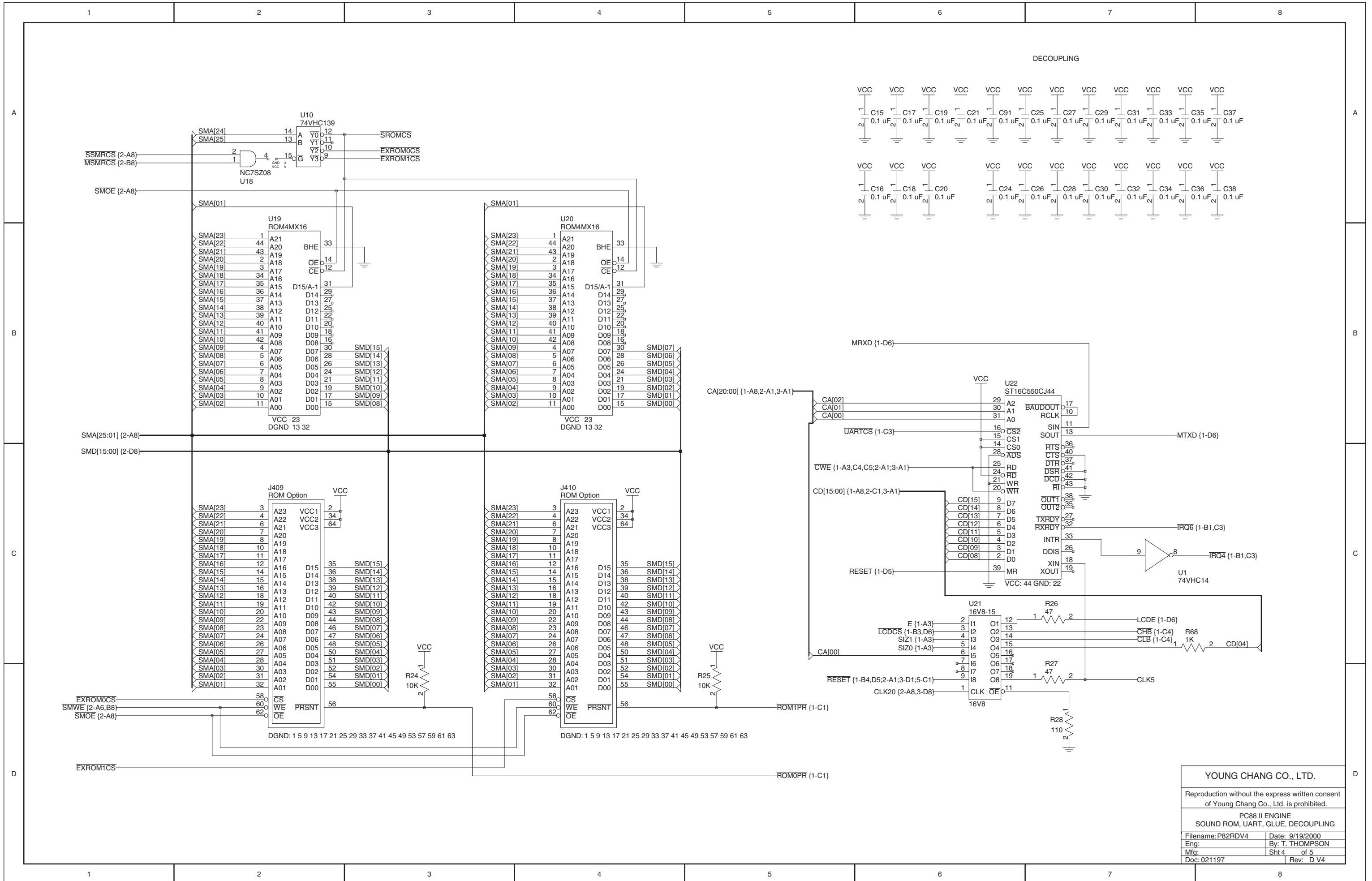

YOUNG CHANG CO., LTD.
 Reproduction without the express written consent of Young Chang Co., Ltd. is prohibited.
 PC88 II ENGINE
 SOUND ROM, UART, GLUE, DECOUPLING
 Filename: P82RDV4 Date: 9/19/2000
 Eng: By: T. THOMPSON
 Mfg: Sht 4 of 5
 Doc: 021197 Rev: D V4

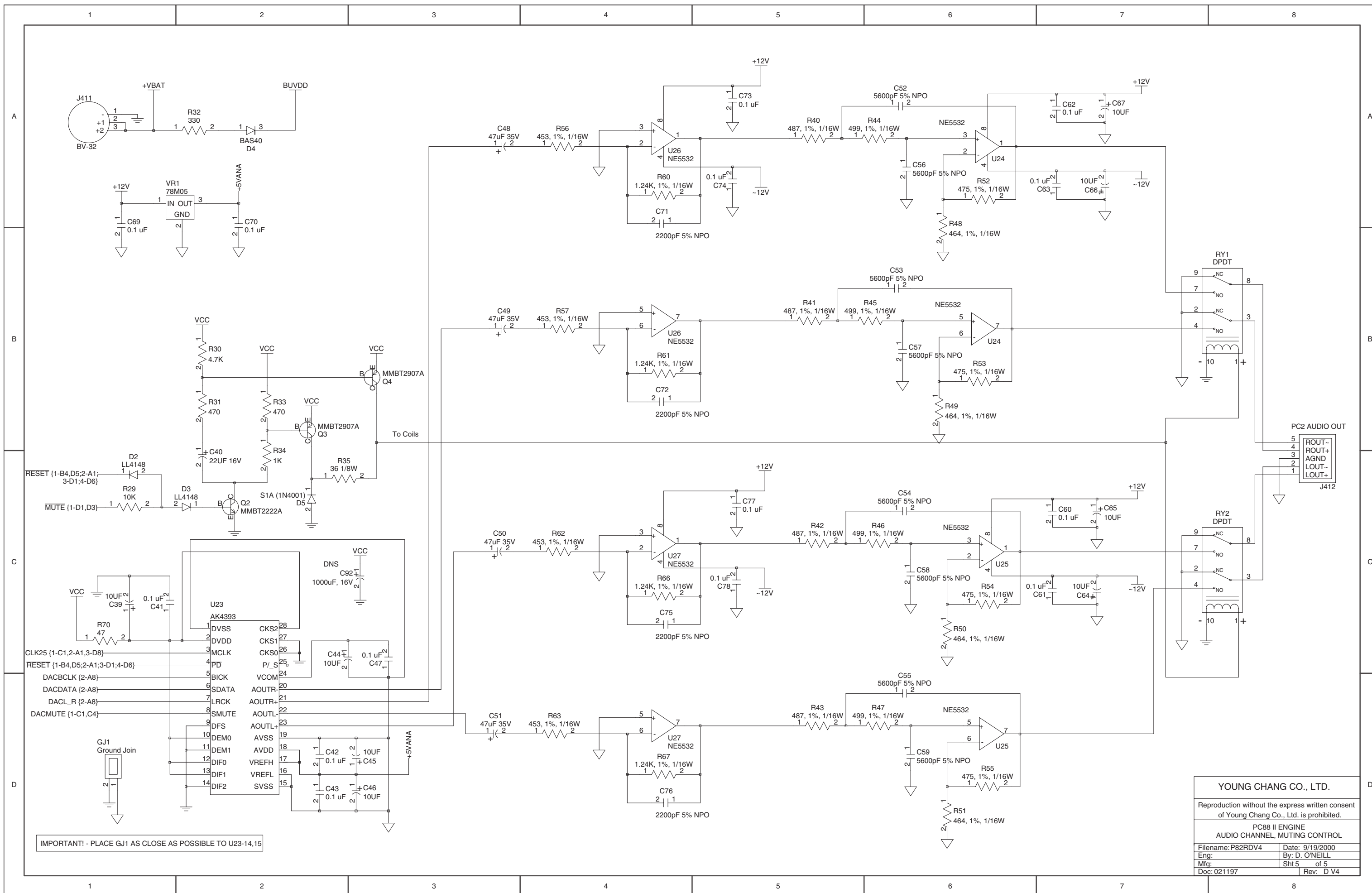

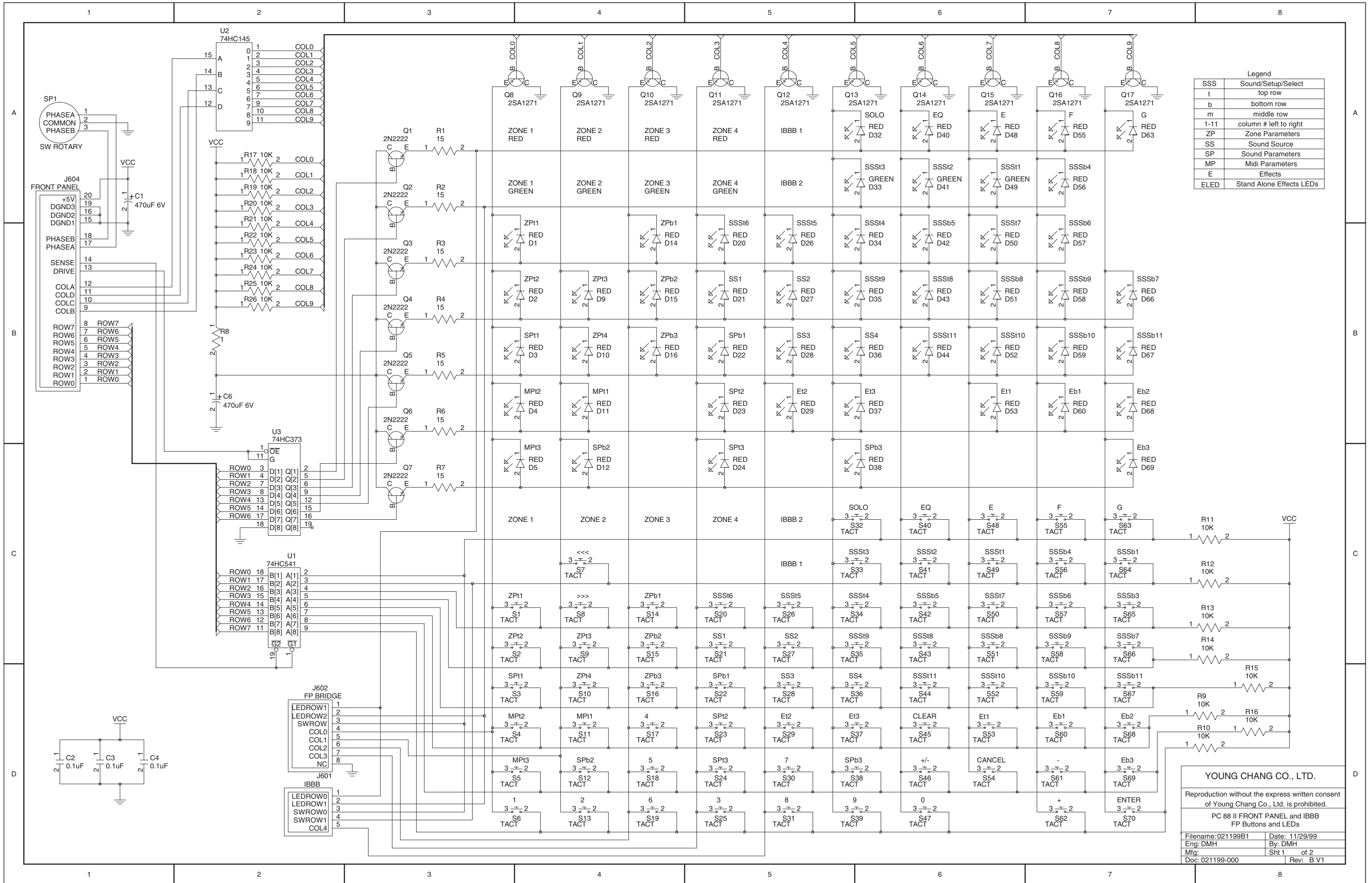

Legend

SSS	Sound/Setup/Select
t	top row
b	bottom row
m	middle row
1-11	column # left to right
ZP	Zone Parameters
SS	Sound Source
SP	Sound Parameters
MP	Midi Parameters
E	Effects
ELED	Stand Alone Effects LEDs

YOUNG CHANG CO., LTD.

Reproduction without the express written consent of Young Chang Co., Ltd. is prohibited.

PC 88 II FRONT PANEL and IBBB FP Buttons and LEDs

Filename: 021199B1	Date: 11/29/99
Eng: DMH	By: DMH
Mfg:	Sht 1 of 2
Doc: 021199-000	Rev: B V1

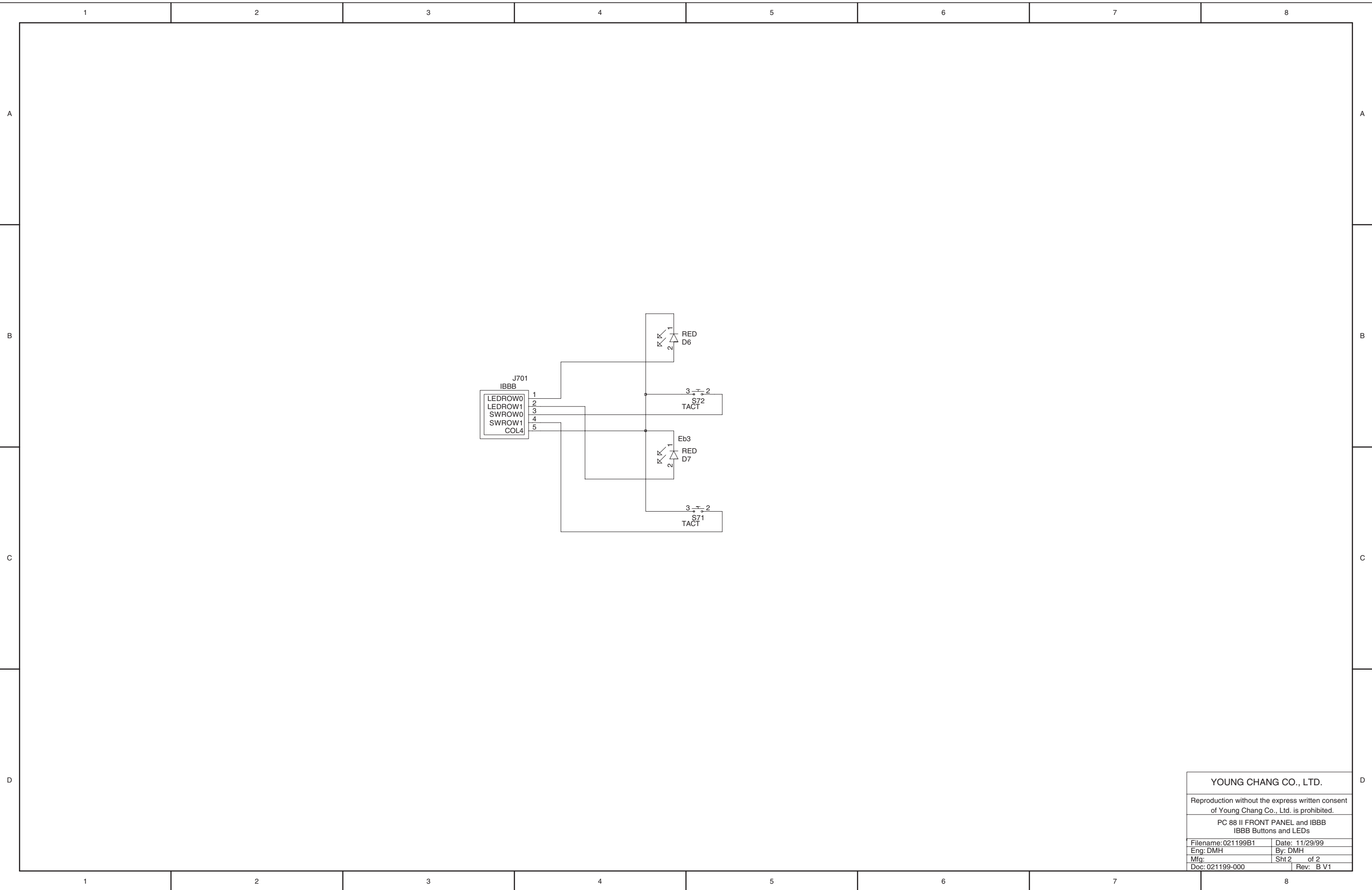

YOUNG CHANG CO., LTD.	
Reproduction without the express written consent of Young Chang Co., Ltd. is prohibited.	
PC 88 II FRONT PANEL and IBBB IBBB Buttons and LEDs	
Filename: 021199B1	Date: 11/29/99
Eng: DMH	By: DMH
Mfg:	Sht 2 of 2
Doc: 021199-000	Rev: B V1

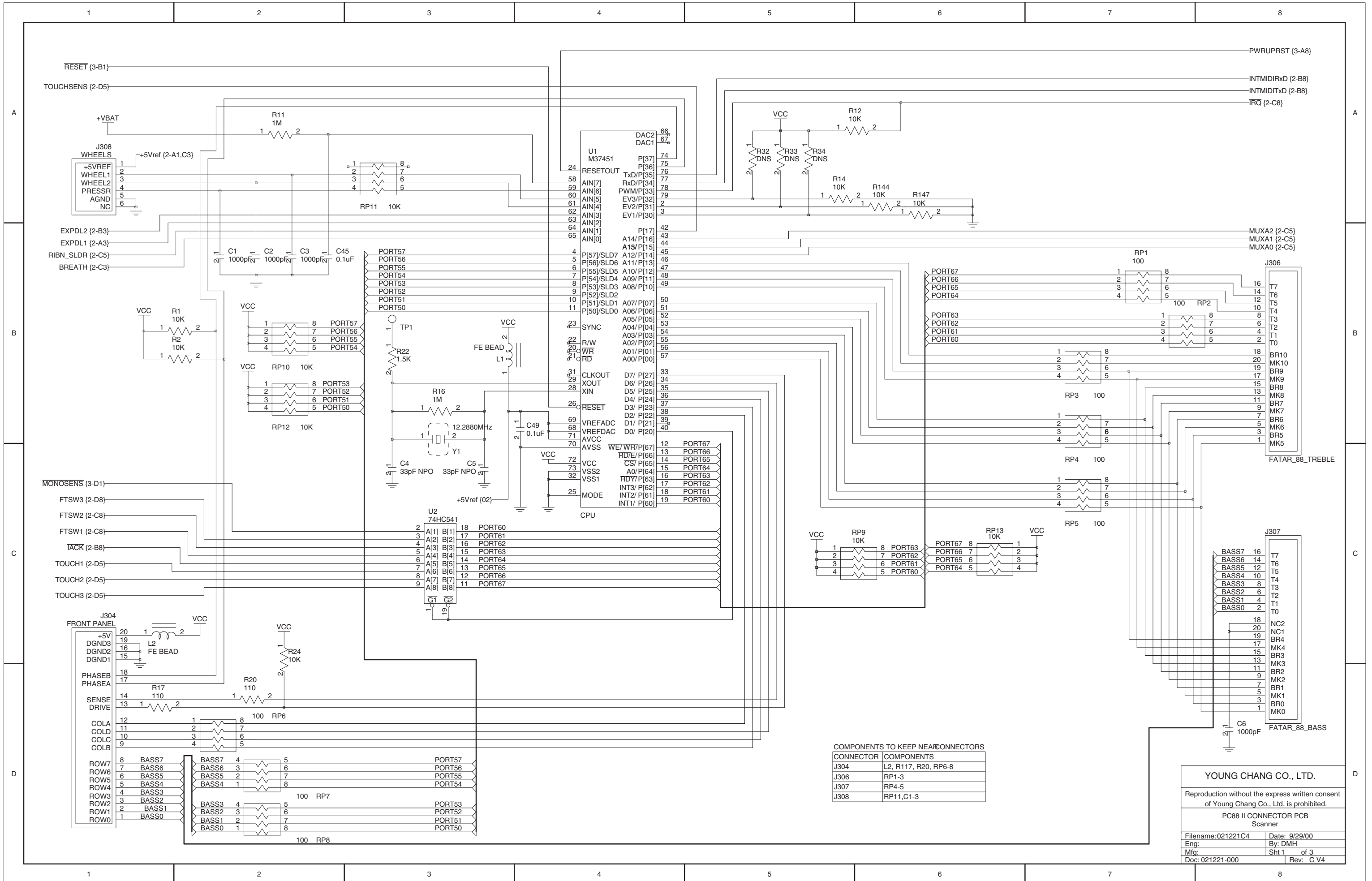

COMPONENTS TO KEEP NEAR CONNECTORS

CONNECTOR	COMPONENTS
J304	L2, R117, R20, RP6-8
J306	RP1-3
J307	RP4-5
J308	RP11, C1-3

YOUNG CHANG CO., LTD.

Reproduction without the express written consent of Young Chang Co., Ltd. is prohibited.

PC88 II CONNECTOR PCB
Scanner

Filename: 021221C4	Date: 9/29/00
Eng:	By: DMH
Mfg:	Sht 1 of 3
Doc: 021221-000	Rev: C V4

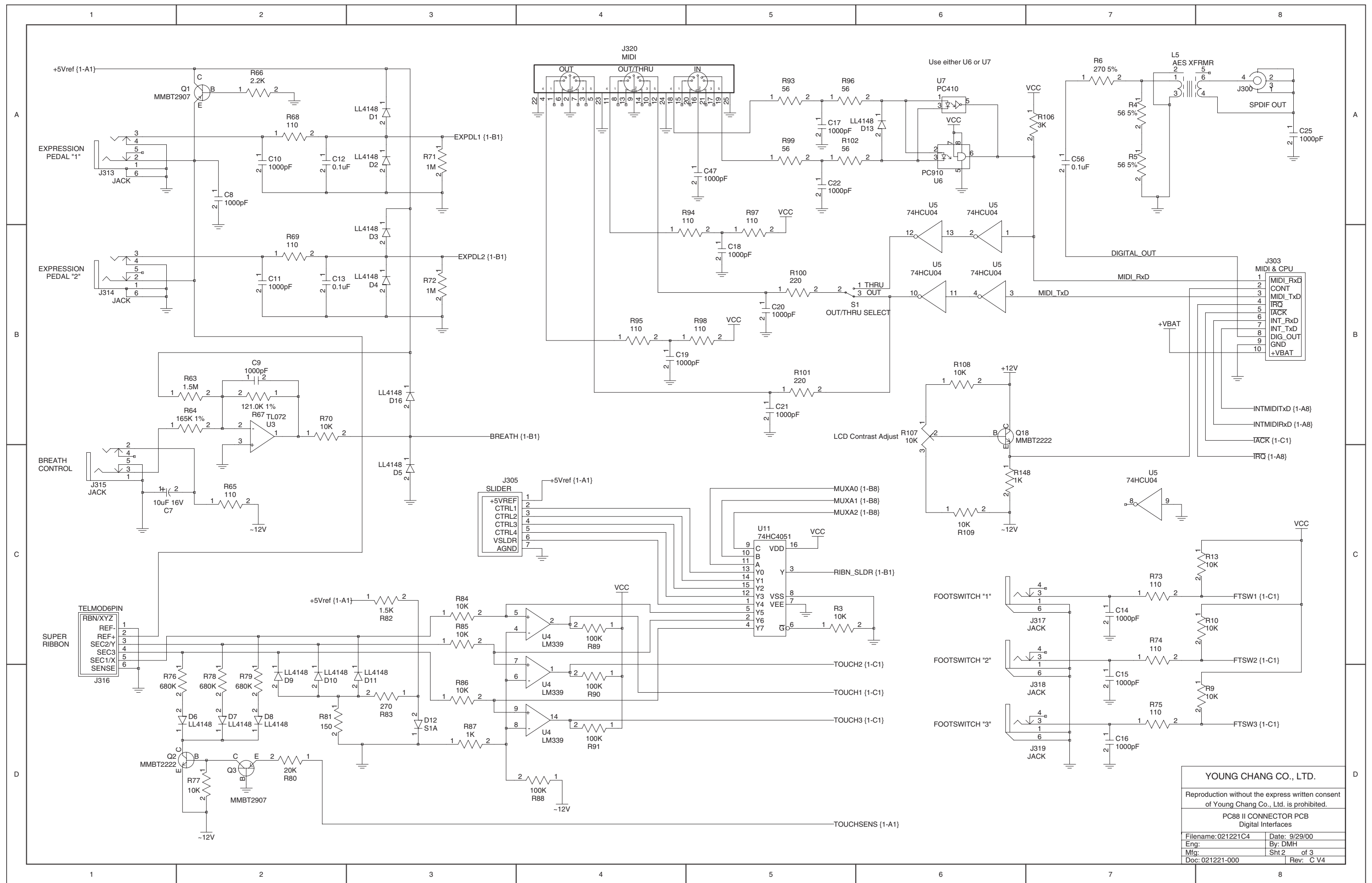

YOUNG CHANG CO., LTD.
 Reproduction without the express written consent of Young Chang Co., Ltd. is prohibited.
PC88 II CONNECTOR PCB
 Digital Interfaces
 Filename: 021221C4 Date: 9/29/00
 Eng: By: DMH
 Mfg: Sht 2 of 3
 Doc: 021221-000 Rev: C V4

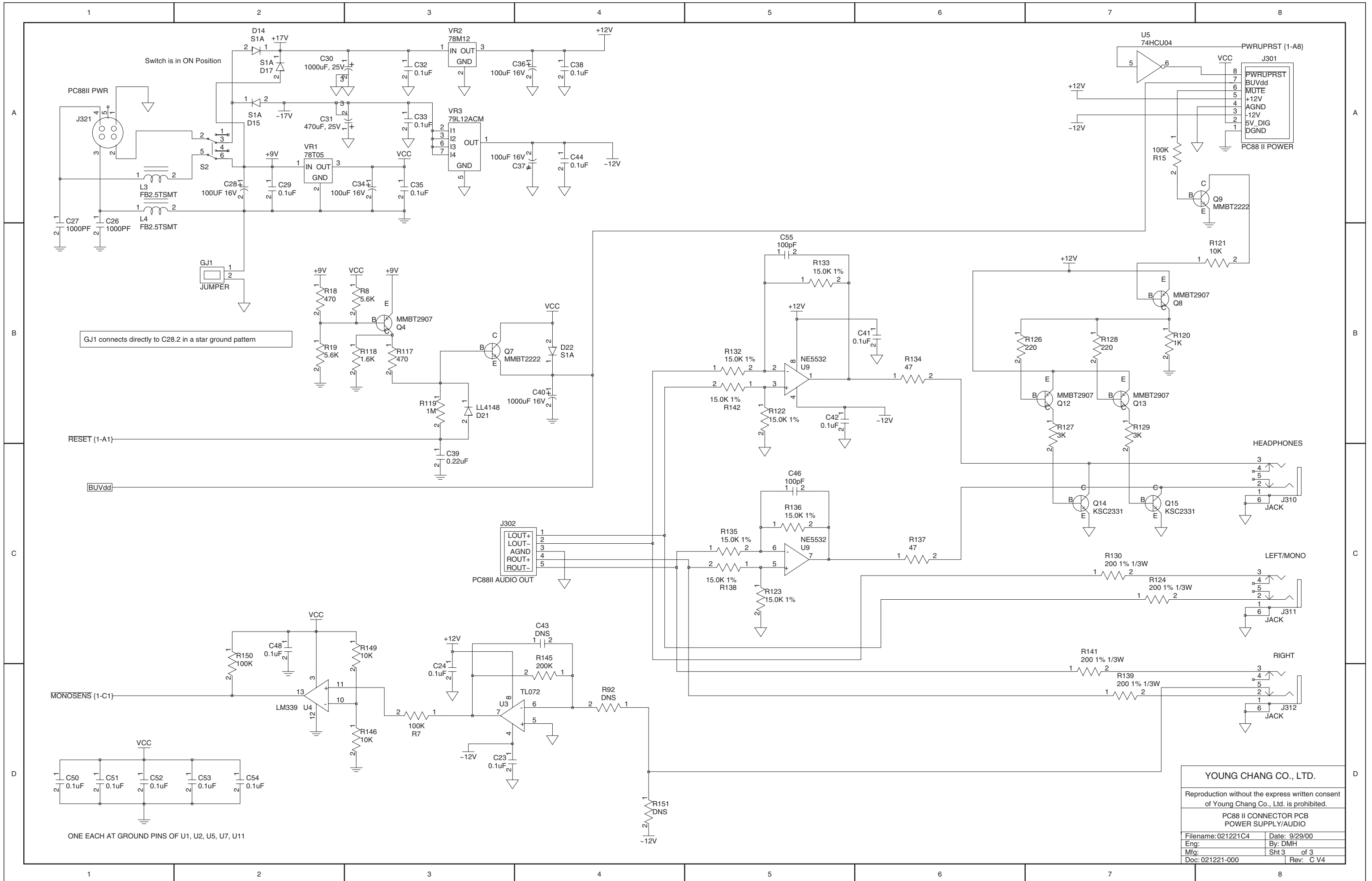

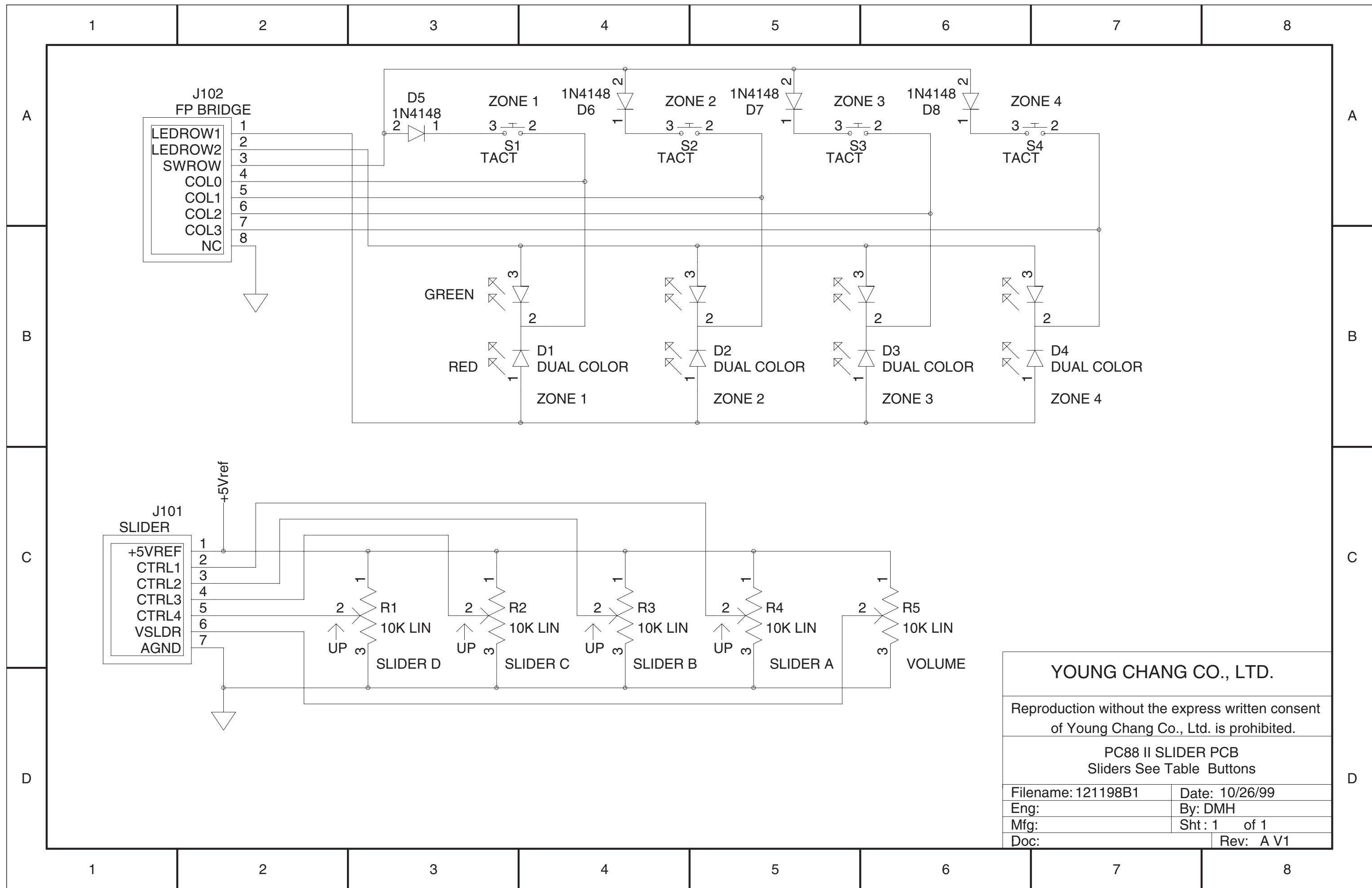

YOUNG CHANG CO., LTD.

Reproduction without the express written consent
of Young Chang Co., Ltd. is prohibited.

PC88 II SLIDER PCB
Sliders See Table Buttons

Filename: 121198B1	Date: 10/26/99
Eng:	By: DMH
Mfg:	Sht: 1 of 1
Doc:	Rev: A V1

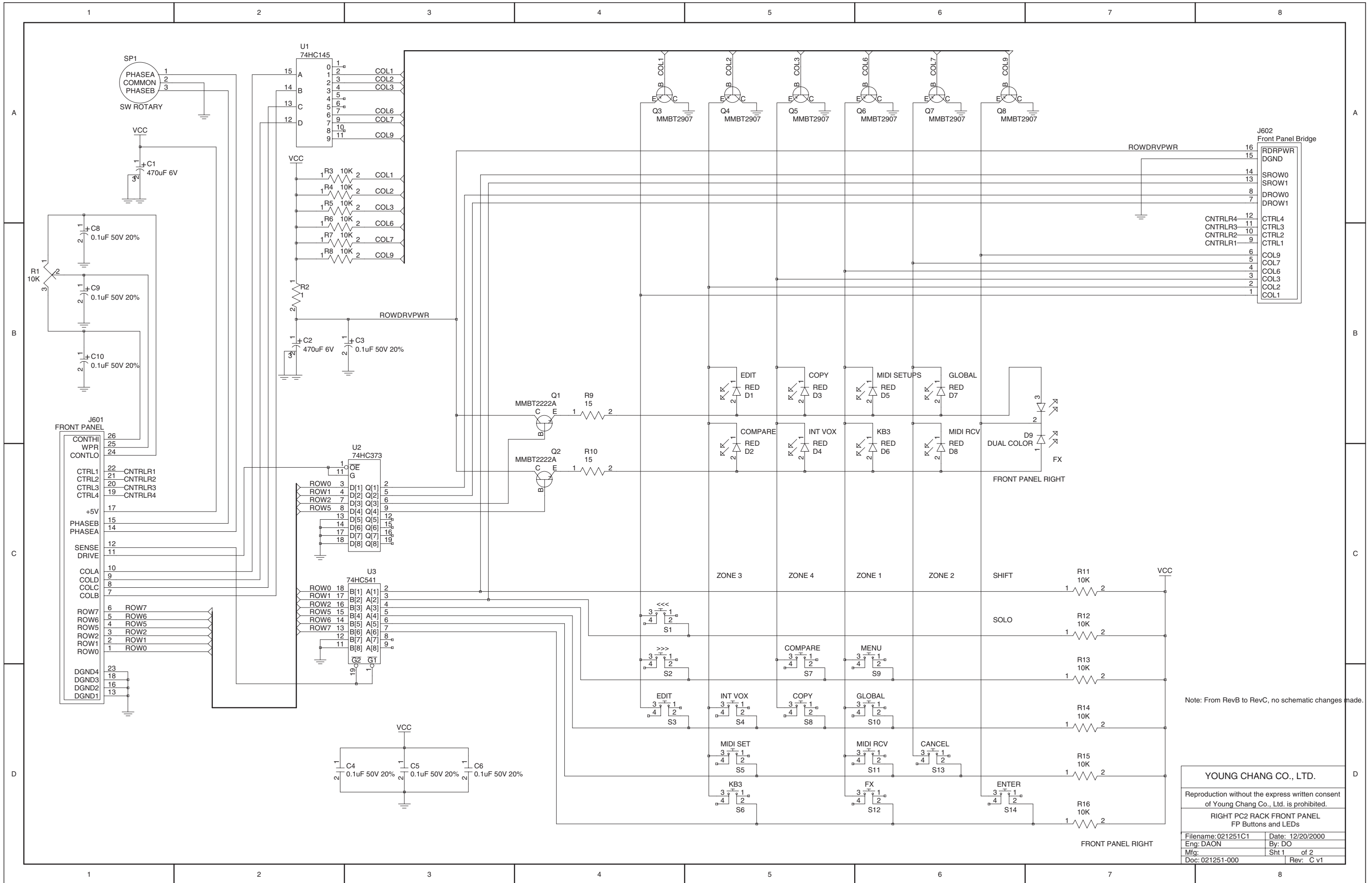

Note: From RevB to RevC, no schematic changes made.

YOUNG CHANG CO., LTD.	
Reproduction without the express written consent of Young Chang Co., Ltd. is prohibited.	
RIGHT PC2 RACK FRONT PANEL FP Buttons and LEDs	
Filename: 021251C1	Date: 12/20/2000
Eng: DAON	By: DO
Mfg:	Sht 1 of 2
Doc: 021251-000	Rev: C v1

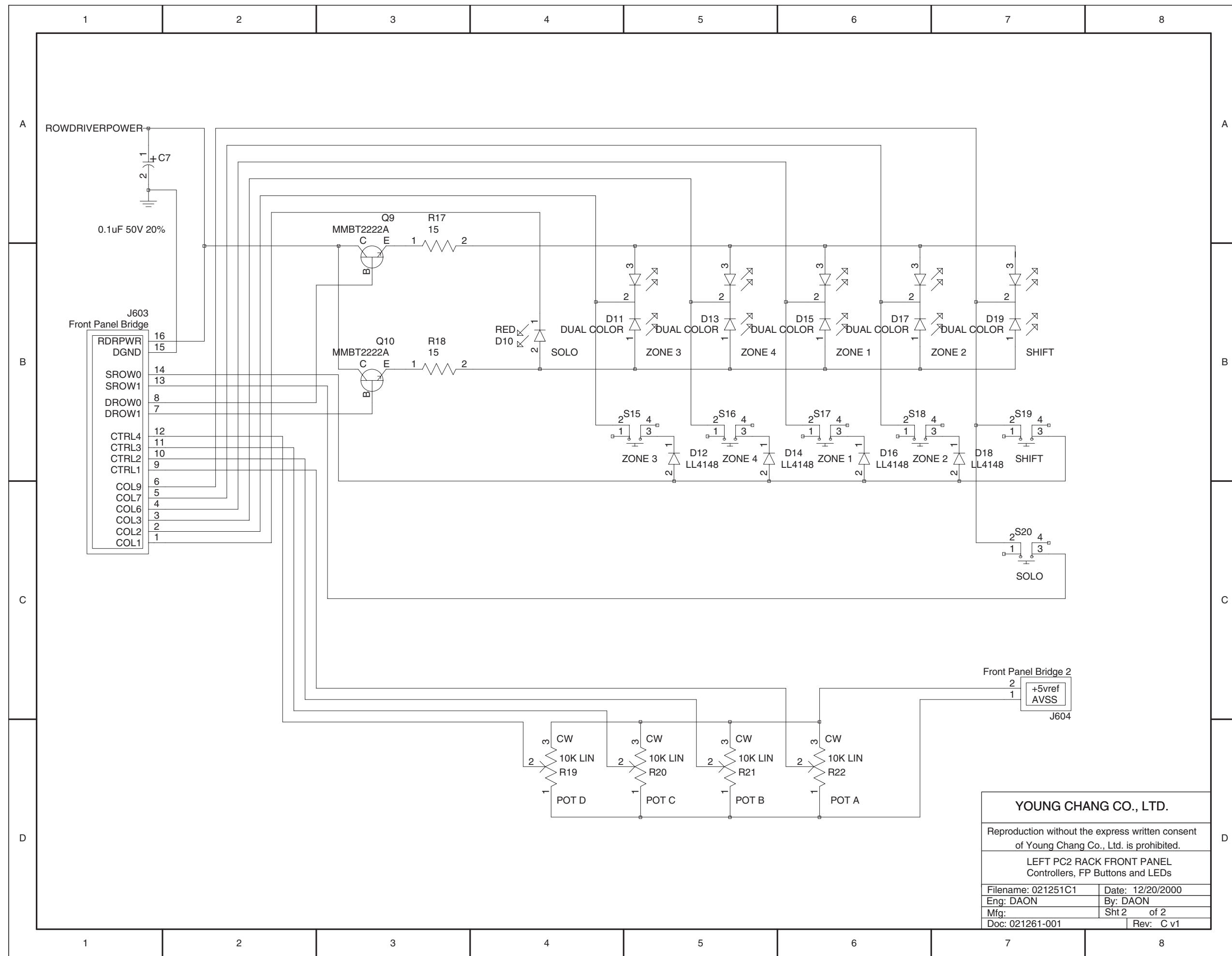

YOUNG CHANG CO., LTD.
 Reproduction without the express written consent of Young Chang Co., Ltd. is prohibited.
 LEFT PC2 RACK FRONT PANEL
 Controllers, FP Buttons and LEDs

Filename: 021251C1	Date: 12/20/2000
Eng: DAON	By: DAON
Mfg:	Sht 2 of 2
Doc: 021261-001	Rev: C v1

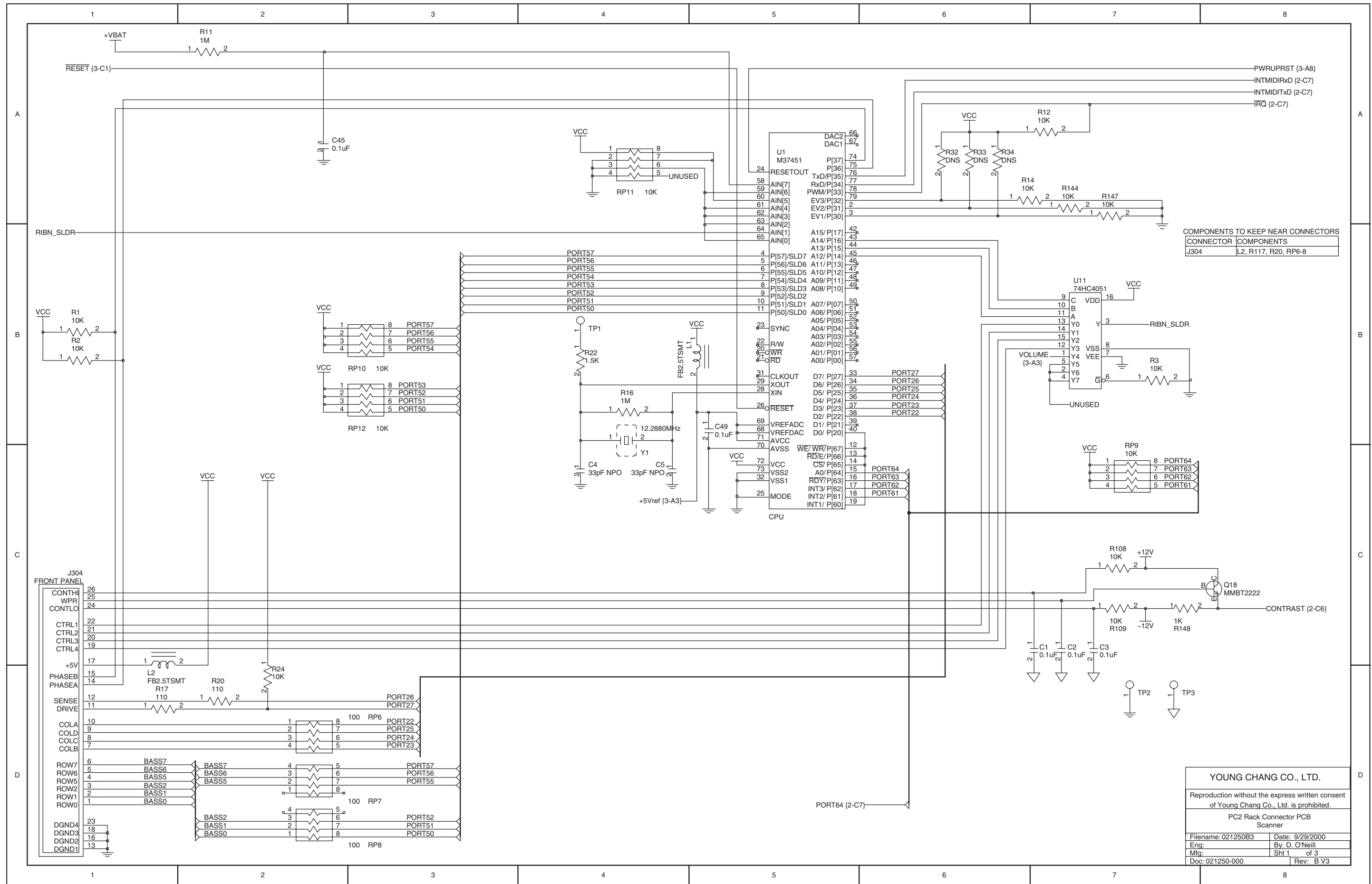

YOUNG CHANG CO., LTD.
 Reproduction without the express written consent of Young Chang Co., Ltd. is prohibited.
 PC2 Rack Connector PCB Scanner
 Filename: 021250B3 Date: 9/29/2000
 Eng: By: D. O'Neill
 Mfg: Sht 1 of 3
 Doc: 021250-000 Rev: B V3

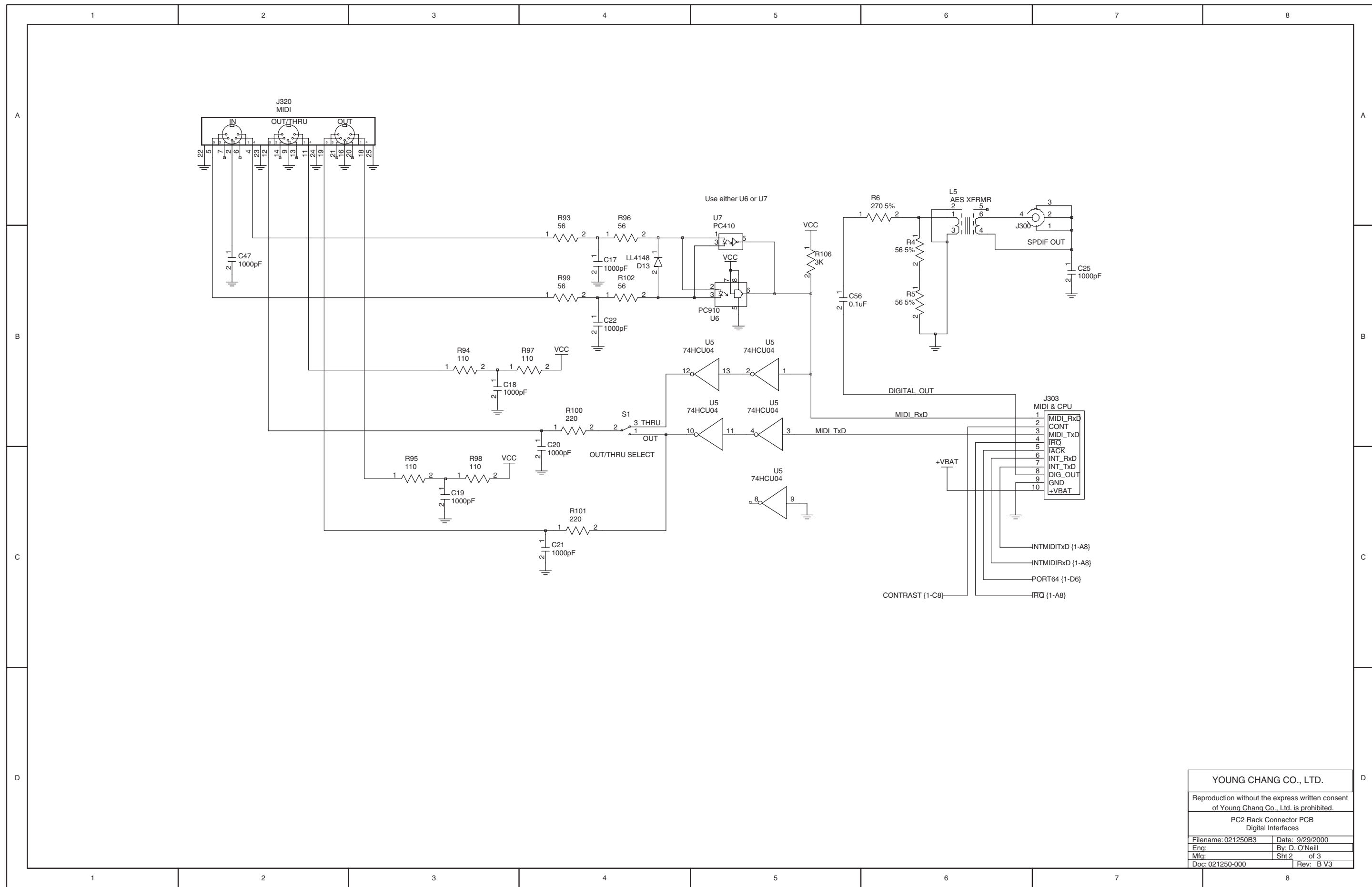

YOUNG CHANG CO., LTD.	
Reproduction without the express written consent of Young Chang Co., Ltd. is prohibited.	
PC2 Rack Connector PCB Digital Interfaces	
Filename: 021250B3	Date: 9/29/2000
Eng:	By: D. O'Neill
Mfg:	Sht 2 of 3
Doc: 021250-000	Rev: B V3

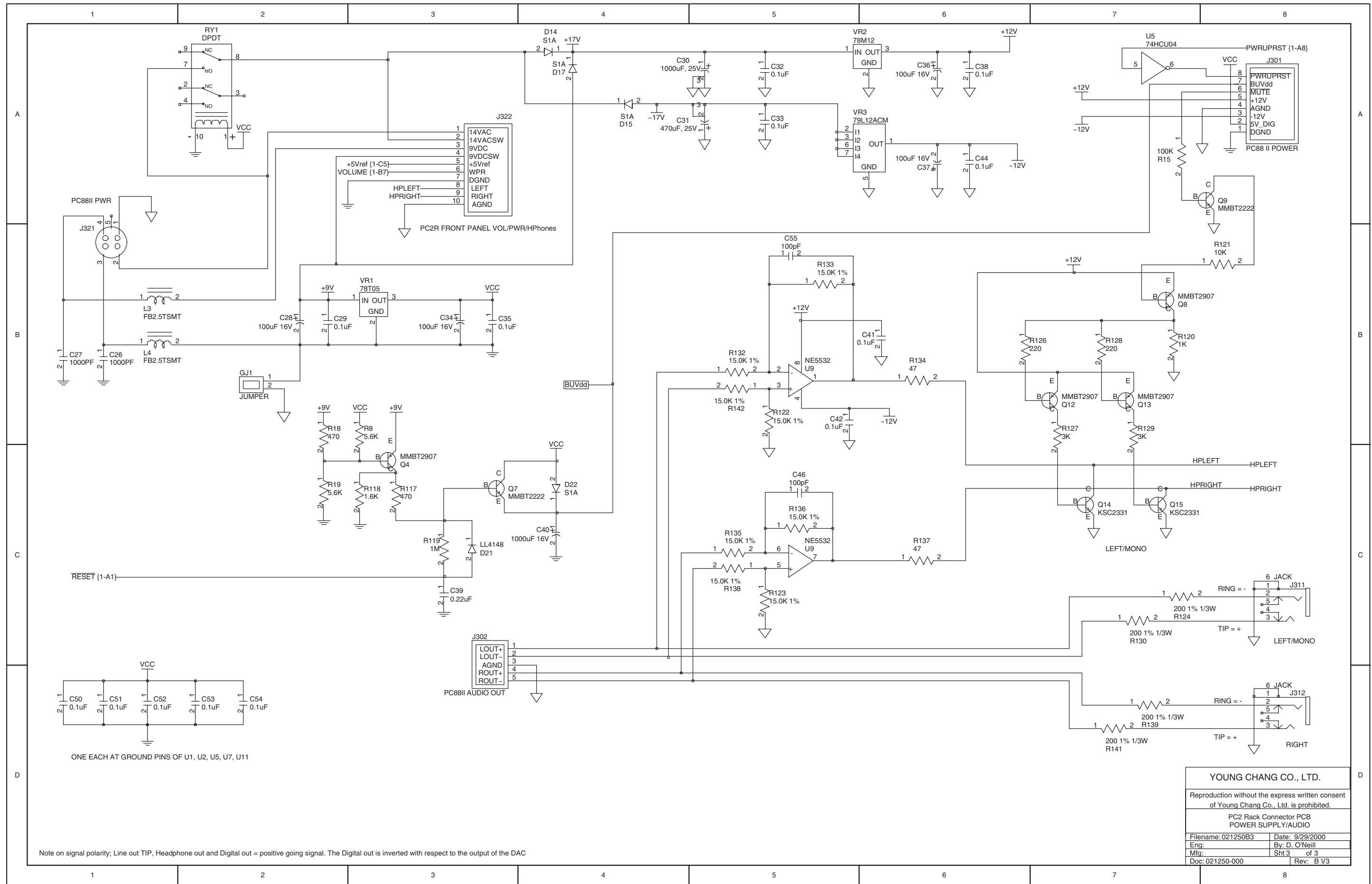

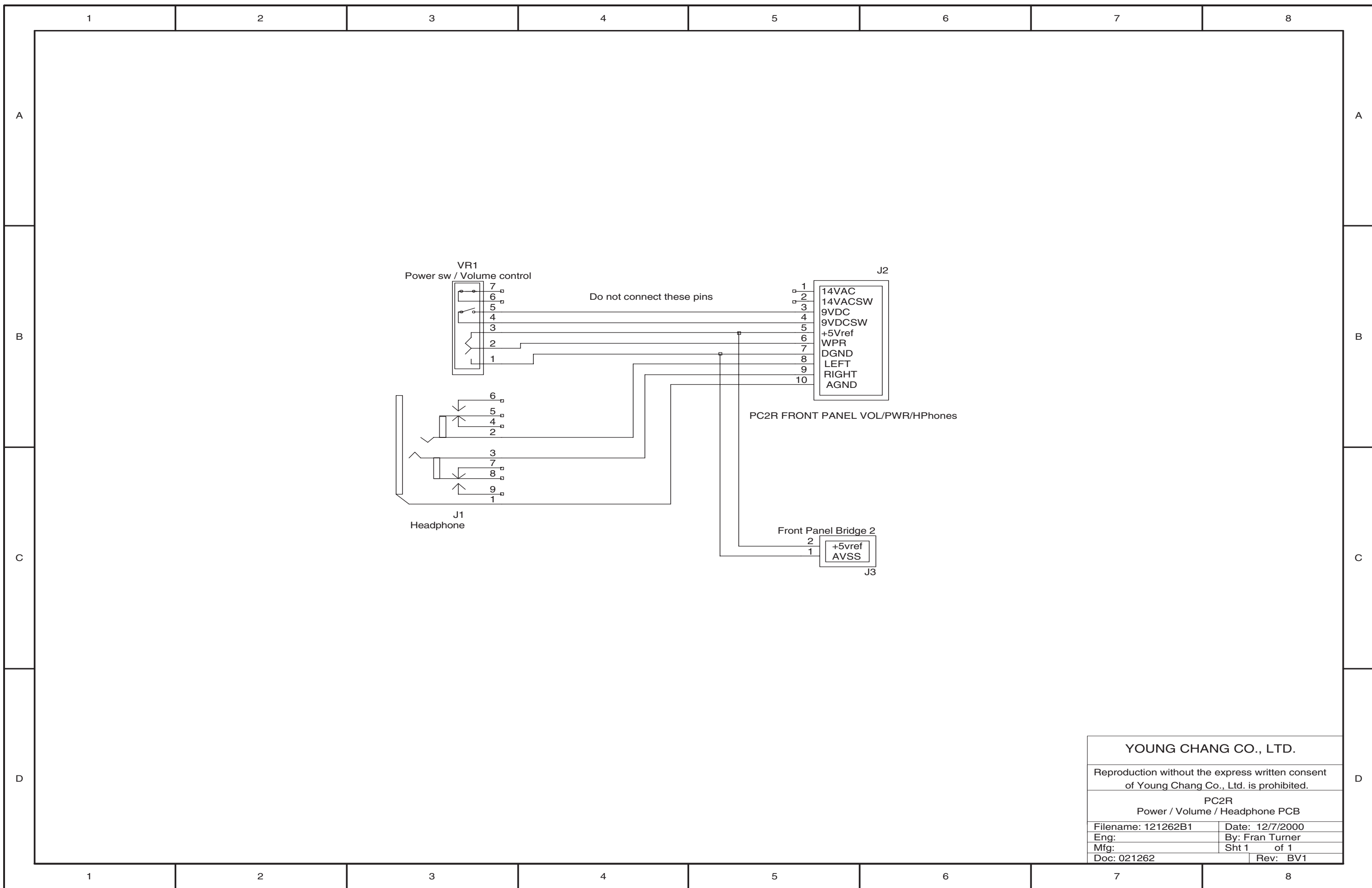

YOUNG CHANG CO., LTD.	
Reproduction without the express written consent of Young Chang Co., Ltd. is prohibited.	
PC2R Power / Volume / Headphone PCB	
Filename: 121262B1	Date: 12/7/2000
Eng:	By: Fran Turner
Mfg:	Sht 1 of 1
Doc: 021262	Rev: BV1

A

- Alpha Wheel Test
 - scanner tests, PC2 5-8
 - scanner tests, PC2R 5-7
- Assembly instructions, 76-note Keyboard Assembly
 - connecting the keyboard 4-21
 - contact boards 4-24
 - replacing contact strips 4-25
 - replacing keys 4-24
 - replacing the keyboard 4-20
- Assembly instructions, 88-note Keyboard Assembly
 - contact boards 4-30, 4-31
 - removing a key weight 4-33
 - replacing contact strips 4-32
 - replacing keys 4-30
 - replacing the keyboard 4-27
- Assembly instructions, keyboard models
 - bottom enclosure 4-6
 - Connector Board 4-10
 - Enclosure Support Walls 4-8
 - Engine Board 4-17
 - Front Panel Board 4-12
 - LCD Board 4-13
 - Mod Wheel Assembly 4-18
 - Polyphony Expansion Board (PCX-1) 4-14
 - Slider Board 4-15
 - top enclosure 4-6
- Assembly instructions, rack models
 - Connector Board 3-4
 - Engine Board 3-6
 - Headphone/Volume/Power Switch Board 3-14
 - LCD Board 3-12
 - Left Front Panel Board 3-13
 - Polyphony Expansion Board (PCX-1) 3-5
 - removing the front panel faceplate 3-9
 - replacing the front panel faceplate 3-8
 - Right Front Panel Board 3-11
 - Top Cover 3-2

B

- Battery
 - removing, PC2 5-5
 - removing, PC2R 5-6
 - replacing, PC2 5-5
 - replacing, PC2R 5-6
- Boot Block
 - entering 5-2
 - installing 5-4
- Boot block
 - installing the Sound ROM Option 5-4
- Bottom Enclosure
 - closing, keyboard models 4-6
 - diagram 76-note keyboard 4-2, 4-19
 - diagram 88-note keyboard 4-3, 4-26
 - opening, 76-note keyboard 4-2
 - opening, 88-note keyboard 4-3
- Burn-in Tests
 - diagnostics 2-3
- Button Test
 - scanner tests, PC2 5-8
 - scanner tests, PC2R 5-7

C

- Cables, keyboard models
 - Connector Board 4-8
 - Engine Board 4-16
 - Front Panel Board 4-11
- Cables, rack models
 - Connector Board 3-3
 - Engine Board 3-6
- Connector Board
 - cables, keyboard models 4-8
 - cables, rack models 3-3
 - diagram, hardware 4-9
 - parts list, keyboard models 6-6
 - parts list, rack models 6-13
 - removing, keyboard models 4-8
 - removing, rack models 3-3
 - replacing, keyboard models 4-10
 - replacing, rack models 3-4
- Contact Boards
 - removing, 76-note keyboard models 4-24
 - removing, 88-note keyboard models 4-30
 - replacing, 76-note keyboard models 4-24
 - replacing, 88-note keyboard models 4-30, 4-31
- Contacts
 - troubleshooting 5-12

D

- Diagnostic Test Modes: description 2-2
- Diagnostic Tests
 - LED 2-5
 - LISA 2-4
 - MABEL 2-4
 - MIDI 2-5
 - PCX-1 MABEL 2-6
 - PCX-1 RAM 2-5
 - PCX-1 ROM 2-5
 - PCX-1 RW 2-5
 - PCX-1 SROM 2-6
 - RAM 2-4
 - Read-write 2-4
 - ROM 2-4
 - Sound ROM 2-4
 - ZRAM 2-5
- Diagnostics
 - Burn-in Tests 2-3
 - entering tests 2-2
 - list of tests 2-1
 - test results 2-3
- Diagram, keyboard models
 - bottom enclosure 76-note keyboard 4-2, 4-19
 - bottom enclosure 88-note keyboard 4-3, 4-26
 - Connector Board hardware 4-9
 - Engine Board 4-16
 - Front Panel Board 4-11
 - front panel layout 1-3, 1-4, 1-5
 - Interconnect 5-14
 - key spring, 76-note keyboard 4-23
 - key spring, 88-note keyboard 4-29
 - key weights 88-note keyboard models 4-32
 - rear panel 1-2, 4-4
 - Slider Board 4-14

- top cover and bottom enclosure 4-5
- top enclosure, board locations 4-7
- top enclosure, enclosure support wall locations 4-7
- Diagram, rack models
 - front panel 1-6, 1-7, 1-8
 - front panel assembly 3-8
 - front panel faceplate 3-10
 - Headphone/Vol/Pwr Sw Board connection 3-13
 - Interconnect 5-13
 - rear panel 1-6
 - removing the Polyphony Expansion Board (PCX-1) 3-5
 - removing the top cover 3-2
- Disassembly instructions, 76-note Keyboard Assembly
 - contact boards 4-24
 - disconnecting the keyboard 4-21
 - removing contact strips 4-25
 - removing keys 4-22
 - removing the keyboard 4-19
- Disassembly instructions, 88-note Keyboard Assembly
 - contact boards 4-30
 - removing a key weight 4-32
 - removing contact strips 4-31
 - removing keys 4-27
 - removing the keyboard 4-26
- Disassembly instructions, keyboard models
 - bottom enclosure 76-note keyboard 4-2
 - bottom enclosure 88-note keyboard 4-3
 - Connector Board 4-8
 - Enclosure Support Walls 4-8
 - Engine Board 4-15
 - Front Panel Board 4-10
 - LCD Board 4-13
 - Mod Wheel Assembly 4-17
 - Polyphony Expansion Board (PCX-1) 4-13
 - Slider Board 4-14
 - top enclosure 4-4
- Disassembly instructions, rack models
 - Connector Board 3-3
 - Engine Board 3-6
 - Headphone/Volume/Power Switch Board 3-14
 - LCD Board 3-11
 - Left Front Panel Board 3-12
 - Polyphony Expansion Board (PCX-1) 3-5
 - removing the front panel assembly 3-8
 - removing the front panel faceplate 3-9
 - Right Front Panel Board 3-10
 - Top Cover 3-2

E

- Enclosure Support Walls
 - removing, keyboard models 4-8
 - replacing, keyboard models 4-8
- Engine Board
 - cables, keyboard models 4-16
 - cables, rack models 3-6
 - diagram, keyboard models 4-16
 - parts list 6-3
 - removing, keyboard models 4-15
 - removing, rack models 3-6
 - replacing, keyboard models 4-17
 - replacing, rack models 3-6
- Entering Diagnostic Tests 2-2

F

- Final Assembly
 - parts list, 76-note keyboard models 6-9
 - parts list, 88-note keyboard models 6-11
 - parts list, rack models 6-16
- Front Panel
 - diagram, keyboard models 1-3, 1-4, 1-5
 - diagram, rack models 1-6, 1-7, 1-8
 - features, keyboard models 1-3
 - features, rack models 1-7
- Front Panel Assembly, rack models
 - description, front panel boards 3-9
 - diagram 3-8
 - diagram, front panel faceplate 3-10
 - diagram, Headphone/Vol/Pwr Sw Board connection 3-13
 - parts list 6-14
 - removing the front panel assembly 3-8
 - removing the front panel faceplate 3-9
 - replacing the front panel assembly 3-8
 - replacing the front panel faceplate 3-9
- Front Panel Board
 - cables, keyboard models 4-11
 - diagram, keyboard models 4-11
 - parts list 6-5
 - removing, keyboard models 4-10
 - replacing, keyboard models 4-12
- Front Panel Knobs Test
 - scanner tests, PC2R 5-7

H

- Headphone & Power Switch Assembly
 - parts list 6-15
- Headphone/Volume/Power Switch Board
 - removing, rack models 3-14
 - replacing, rack models 3-14

K

- Keyboard
 - Dead 5-12
 - Dead Note(s) 5-12
 - noise 5-12
 - scanner tests PC2 5-9
- Keyboard Assembly
 - parts list, 76-note keyboard models 6-10
 - parts list, 88-note keyboard models 6-12
- Keyboard Assembly, 76-note keyboard models
 - connecting the keyboard 4-21
 - contact boards 4-24
 - disconnecting the keyboard 4-21
 - key spring, diagram 4-23
 - natural/white keys description 4-23
 - removing contact strips 4-25
 - removing keys 4-22
 - removing the keyboard 4-19
 - replacing contact strips 4-25
 - replacing keys 4-24
 - replacing the keyboard 4-20
 - sharp/black keys description 4-23
- Keyboard Assembly, 88-note keyboard models
 - contact boards 4-30, 4-31

diagram, key weights 4-32
 key spring, diagram 4-29
 natural/white keys description 4-28
 removing a key weight 4-32
 removing contact strips 4-31
 removing keys 4-27
 removing the keyboard 4-26
 replacing a key weight 4-33
 replacing contact strips 4-32
 replacing keys 4-30
 replacing the keyboard 4-27
 sharp/black keys description 4-29

L

LCD Board
 parts list, keyboard models 6-8
 parts list, rack models 6-15
 removing, keyboard models 4-13
 removing, rack models 3-11
 replacing, keyboard models 4-13
 replacing, rack models 3-12
LED: diagnostic test 2-5
Left Front Panel Board
 parts list 6-14
 removing, rack models 3-12
 replacing, rack models 3-13
LISA: diagnostic test 2-4

M

MABEL: diagnostic test 2-4
MIDI: diagnostic test 2-5
Mod Wheel
 scanner tests, PC2 5-9
Mod Wheel Assembly
 parts list 6-8
 removing, keyboard models 4-17
 replacing, keyboard models 4-18

P

PCX-1 MABEL: diagnostic test 2-6
PCX-1 RAM: diagnostic test 2-5
PCX-1 ROM: diagnostic test 2-5
PCX-1 RW: diagnostic test 2-5
PCX-1 SROM: diagnostic test 2-6
Pedals
 continuous, scanner tests, PC2 5-9
 switch, scanner tests, PC2 5-9
Polyphony Expansion Board (PCX-1)
 diagram 3-5
 removing, keyboard models 4-13
 removing, rack models 3-5
 replacing, keyboard models 4-14
 replacing, rack models 3-5

R

RAM: diagnostic test 2-4
Read-write: diagnostic test 2-4
Rear Panel

diagram, keyboard models 1-2, 4-4
 diagram, rack models 1-6
 features, keyboard models 1-2
 features, rack models 1-6

Resets

Hard Reset 5-2
 Soft Reset 5-2

Right Front Panel Board

parts list 6-15
 removing, rack models 3-10
 replacing, rack models 3-11

ROM: diagnostic test 2-4

S

Scanner Tests, PC2

Alpha Wheel 5-8
 Buttons 5-8
 Front Panel Sliders 5-8
 Keyboard 5-9
 Mod Wheels 5-9
 Pedals, continuous 5-9
 Pedals, switch 5-9

Scanner Tests, PC2R

Alpha Wheel 5-7
 Buttons 5-7
 Front Panel Knobs 5-7

Slider Board

diagram, keyboard models 4-14
 parts list 6-9
 removing, keyboard models 4-14
 replacing, keyboard models 4-15

Slider Test

scanner tests, PC2 5-8

Software Updates

file formats 5-3
 installing 5-3

Sound ROM: diagnostic test 2-4

T

Top Cover

removing, rack models 3-2
 replacing, rack models 3-2

Top Enclosure, keyboard models

description 4-7
 diagram, board locations 4-7
 diagram, enclosure support wall locations 4-7
 removing 4-4
 replacing 4-6

Troubleshooting

Audio Problems 5-10
 Front Panel Problems 5-11
 Keyboard Problems 5-12
 Power Problems 5-10

U

User data

saving 5-1

Y

Young Chang Distributors iii

Z

ZRAM: diagnostic test 2-5