

CHASSIS NO. 157.10000 **A**
 MODEL 4784

ORGAN AMPLIFIER

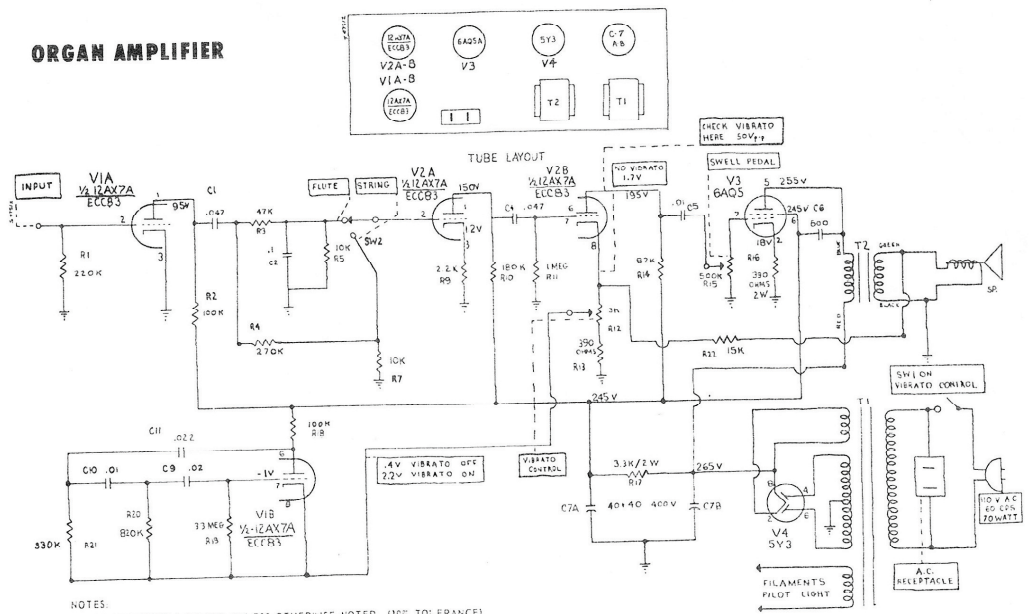

NOTES:
 1. ALL RESISTORS 1/2 WATT UNLESS OTHERWISE NOTED. (10% TOLERANCE)
 2. VALUES OF CAPACITORS IN MFD UNLESS OTHERWISE NOTED. (10% TOLERANCE)
 3. VOLTAGES MEASURED FROM POINTS INDICATED TO GROUND WITH VTVM.

SCHEMATIC DIAGRAM

PARTS LIST

Schematic Location	Part No.	Description	Schematic Location	Part No.	Description	Schematic Location	Part No.	Description
RESISTORS			CAPACITORS			T1	46-006-0	Power Transformer
R1	63-22401	220k	C1, C4	46-2026-0	.047 mfd/400 volts	T2	46-804-0	Output Transformer
R2, R18	64-10401	100k	C2	16-10458	.1 mfd/400 volts	SPKR	46-339-0	Speaker
R4	63-27401	270k	C5, C10	12-103711-0	.01 mfd/400 volts		46-331-2	Microphone
R3	63-47301	47k					89-21	Pilot Light #51
R5, R7	64-10301	10k					46-454-0	Pilot Light Socket Assembly
R9	63-22201	2.2k					46-458-0	AC Receptacle
R10	64-18401	180k	C6	12 501054-6	500 mmf/1000 volts		23-163-0	AC Line Cord 6'
R11	64-10501	1 meg					46-3911-0	Arm, Volume Control with Control Rod
R13	63-39101	390 ohm	C9	12-203714-3	.02 mfd/400 volts			
R14	64-82301	82k	C11	12-223704-6	.022 mfd/400 volts			
R19	64-33501	3.3 meg						
R20	63-82401	820k	C7	46-189-0	40+40 mfd/400 volts electrolytic			
R21	63-33401	330k	MISCELLANEOUS PARTS					
R22	63-15301	15k	SW2	46-692-2	Voicing Switch Special			
R16	63-39121	390 ohm 2W						
R17	63-33211	3.3k 1W						
R12	46-241-2	3k pot C taper Vi-brato control with switch 3w i						
R15	24-5001-3	500k pot Special Swell Control						

Note: All resistors 1/2 watt unless otherwise noted. (10% tolerance.)

4780 Non Amp = 38 watts
 Note: Organ is Air Type w/microphone chamber to input
 4782 Amp 37 keys
 4782 Amp w/60 = 70 watts
 @ 32 watts