

this is the correct connection
Rev 4.6

MIC_IN

Rev 4.6

PCB layout does not match
so MIC signal polarity is wrong

signal polarity markers

+0 = "in-phase", HI
-0 = "out-of-phase", LO

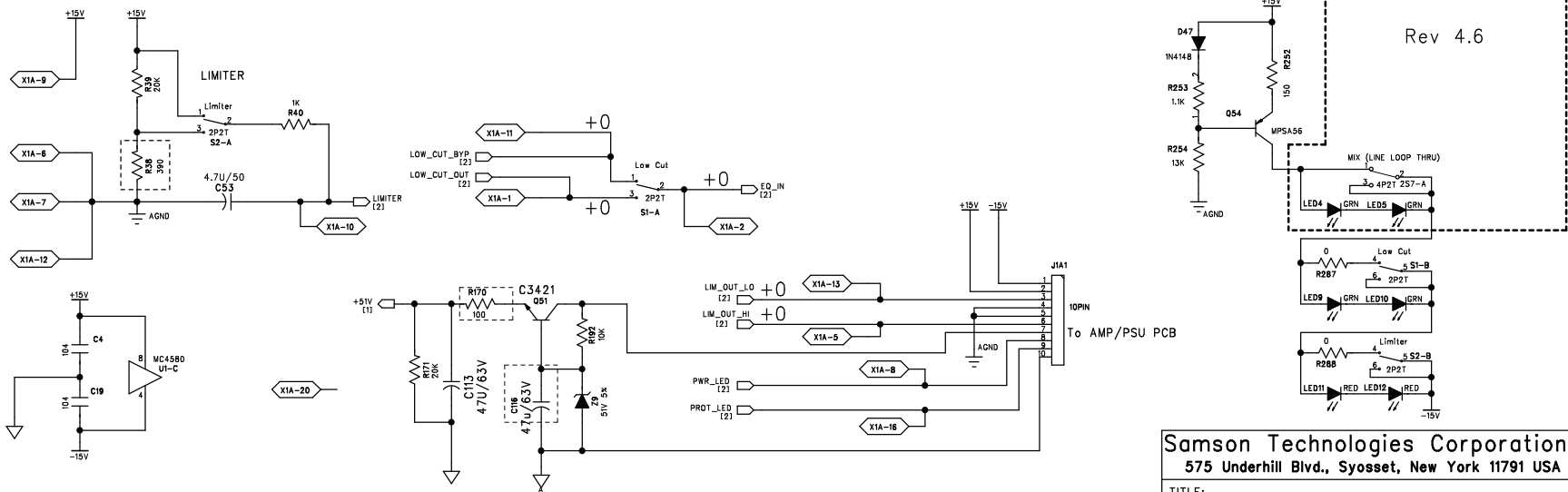

Samson Technologies Corporation
575 Underhill Blvd., Syosset, New York 11791 USA

TITLE: DB500A PREAMP 1					
DRAWN: L.H	DATED: 09/13/02	Revised: DON 02.10.03	DATED:	APPROVED:	DATED:
DWG NO: PT-X-XXXX-XX	SCALE:	SIZE: A2	REV: 4.6	SHEET: 1 OF 5	

XLR & Switch PCB

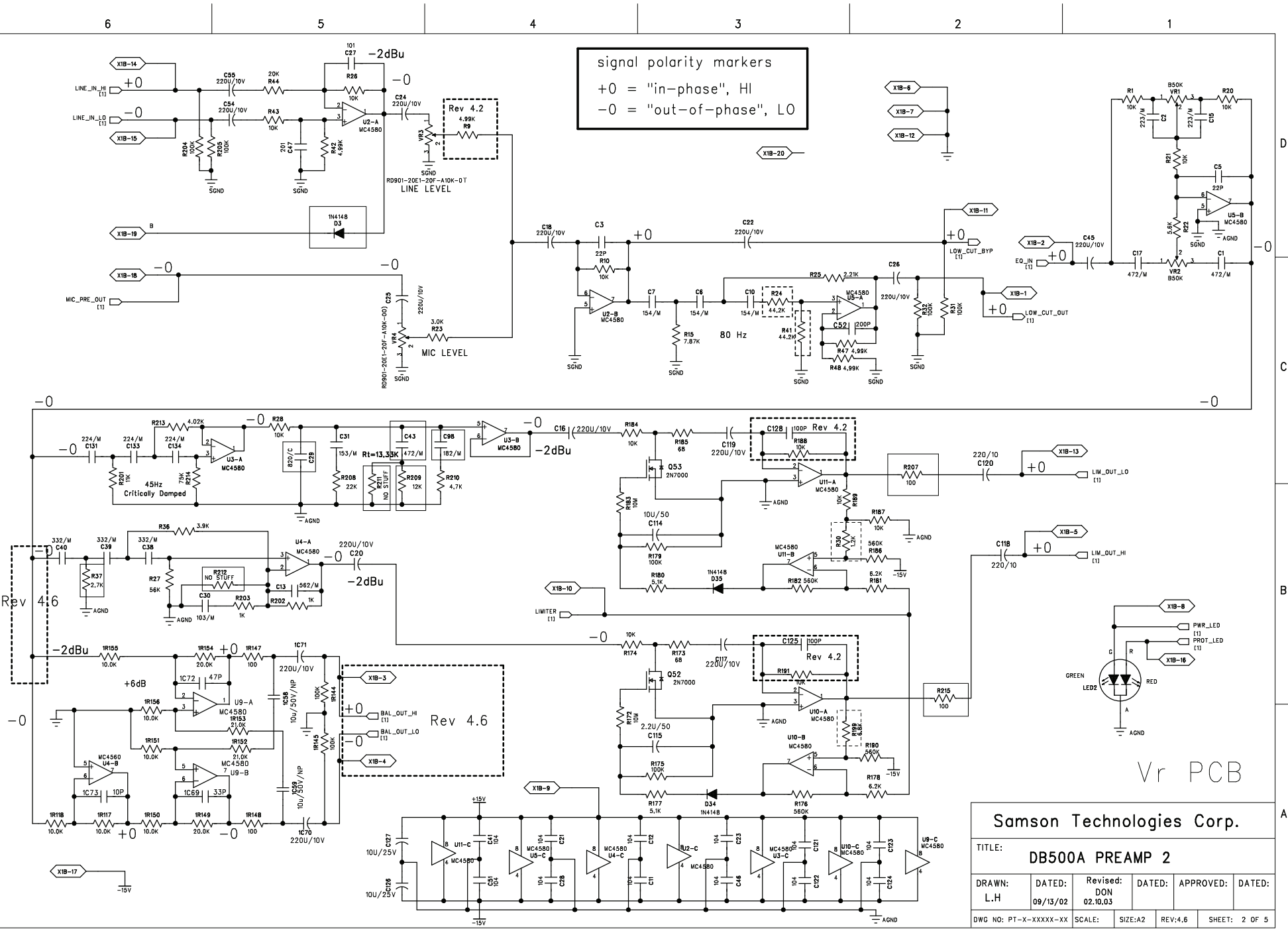

Samson Technologies Corp.					
TITLE: DB500A PREAMP 2					
DRAWN: L.H	DATED: 09/13/02	Revised: DON 02.10.03	DATED:	APPROVED:	DATED:
DWG NO: PT-X-XXXX-XX		SCALE:	SIZE:A2	REV:4.6	SHEET: 2 OF 5

6

5

4

3

2

1

D

C

B

A

D

C

B

A

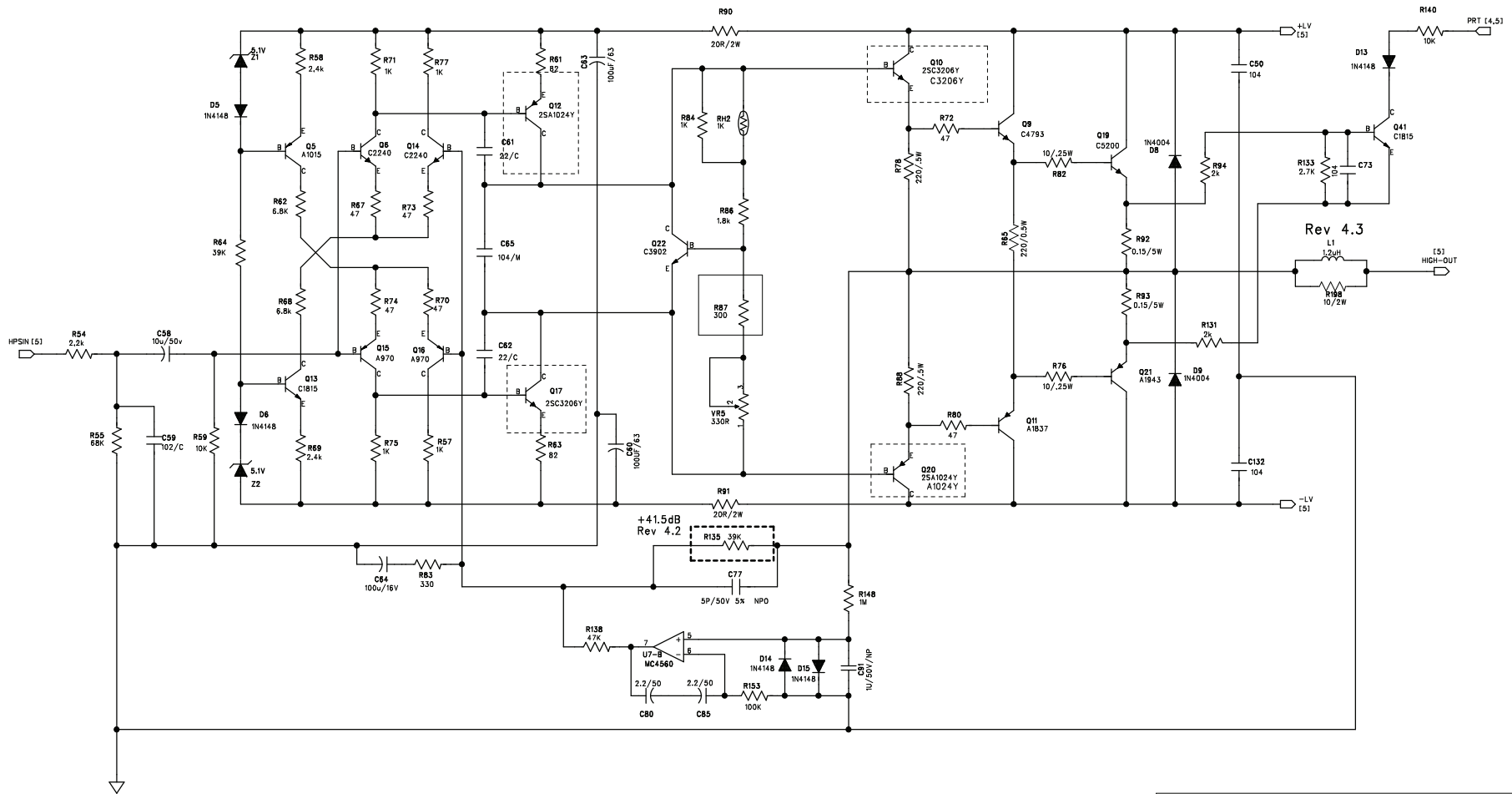

Samson Technologies Corp.					
TITLE: DB500A HF-AMP					
DRAWN:	DATED:	Revised:	DATED:	APPROVED:	DATED:
L.H	09/13/02	DON			
DWG NO: PT-X-XXXX-XX	SCALE:	SIZE:A2	REV:4.5	SHEET: 3 OF 5	

6

5

4

3

2

1

D

C

B

A

D

C

B

A

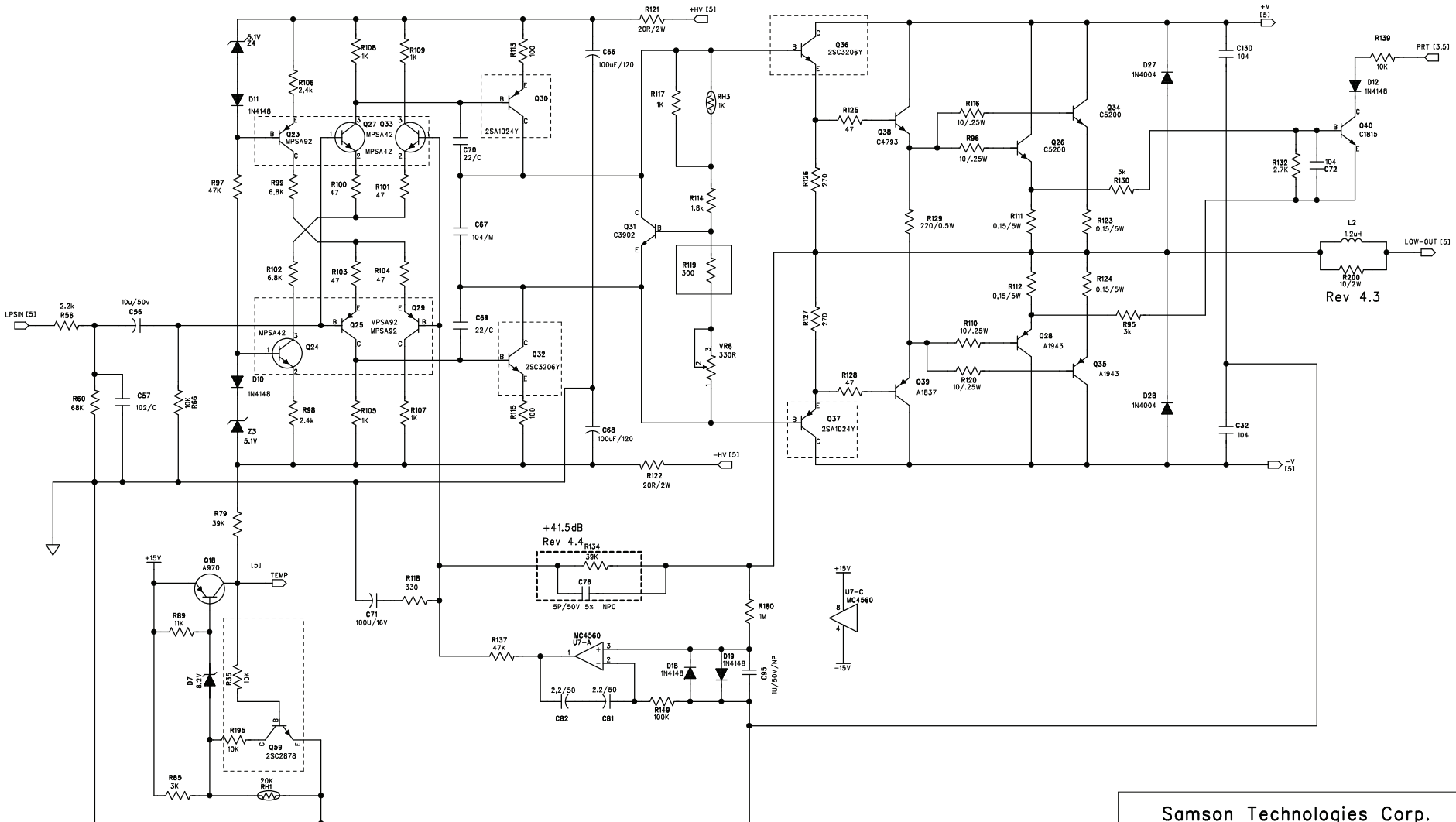

Rev 4.3

Samson Technologies Corp.					
TITLE: DB500A LF-AMP					
DRAWN: L.H	DATED: 09/13/02	Revised: DON	DATED:	APPROVED:	DATED:
DWG NO: PT-X-XXXX-XX		SCALE:	SIZE:A2	REV:4.5	SHEET: 4 OF 5

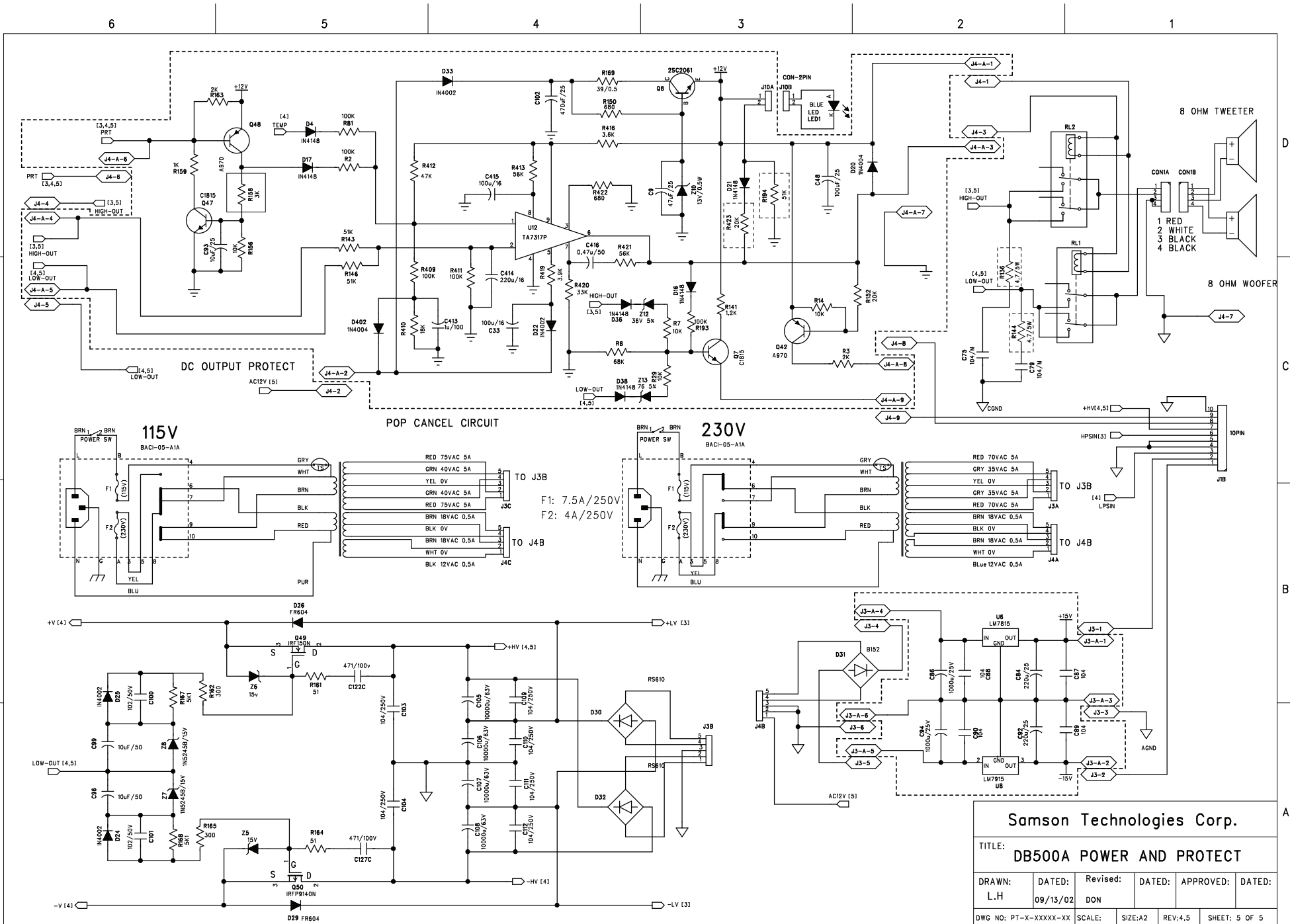

Samson Technologies Corp.					
TITLE: DB500A POWER AND PROTECT					
DRAWN: L.H.	DATED: 09/13/02	Revised: DON	DATED:	APPROVED:	DATED:
DWG NO: PT-X-XXXX-XX	SCALE:	SIZE: A2	REV: 4.5	SHEET: 5 OF 5	