

V1 - 12AX7WA/EH
V2,3 - 12AX7

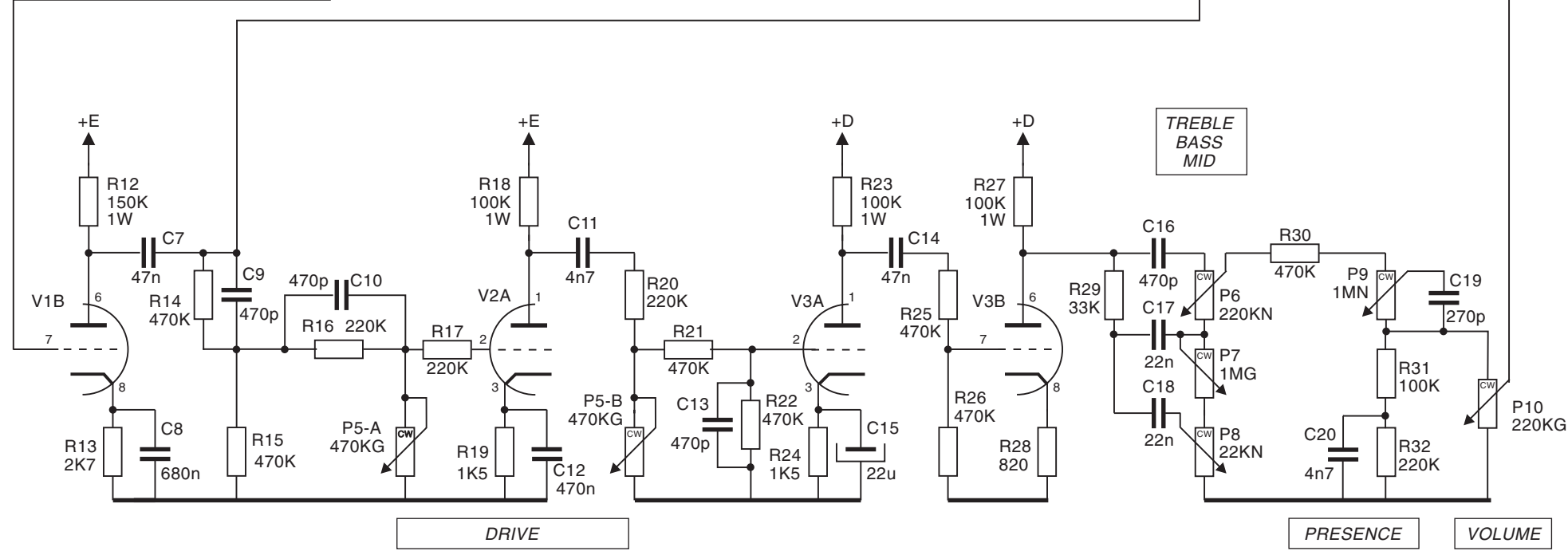

IC1 - OP249
 IC2 - TL071
 IC3 - TL061
 T1 - BD136
 T2 - BD135

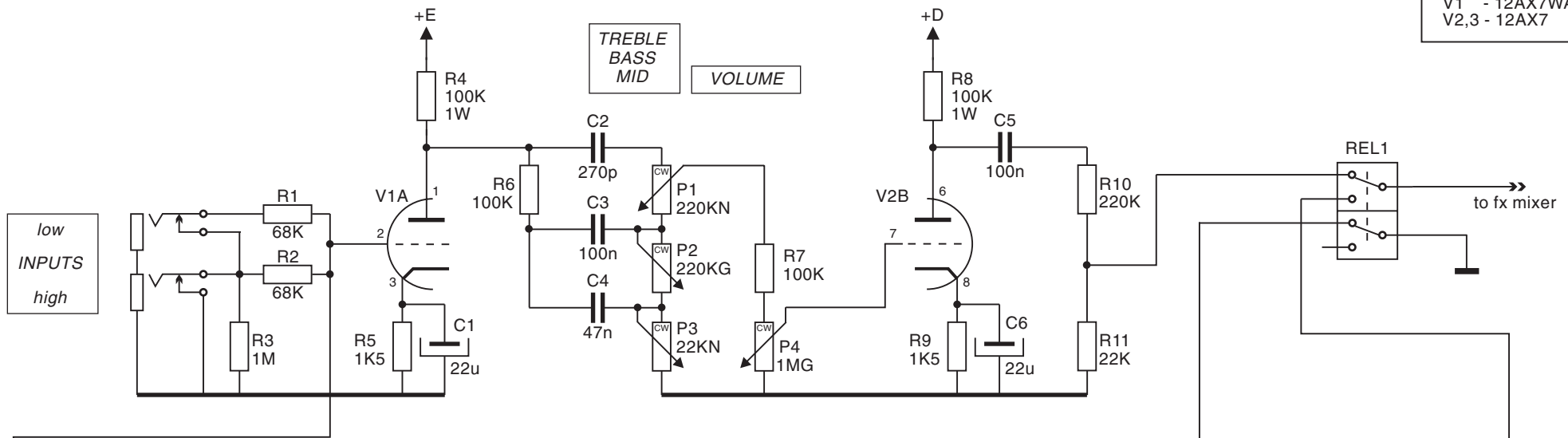
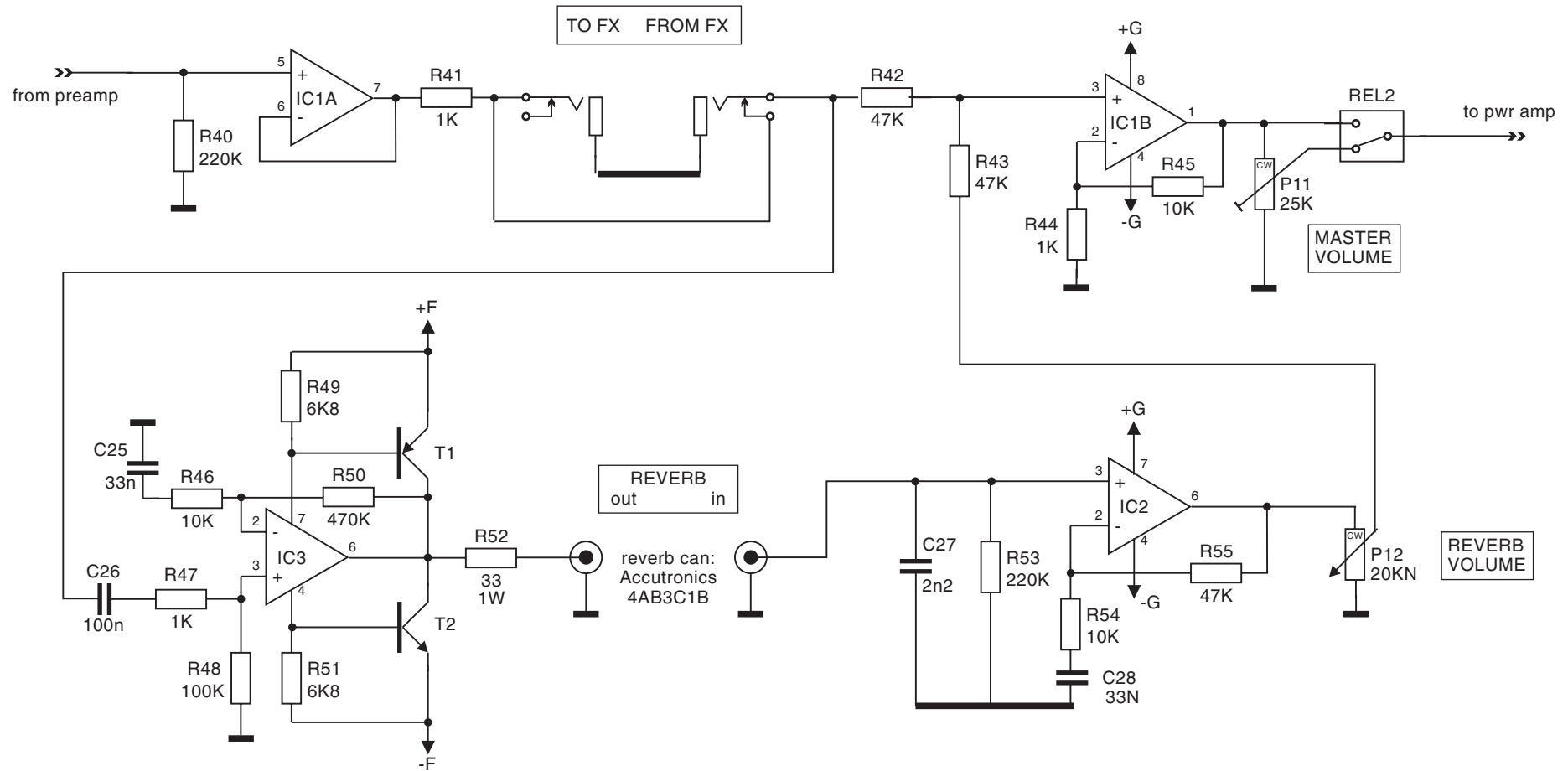

KOCH
GUITAR ELECTRONICS
 Amersfoort
 The Netherlands

© Copyright 1995, Koch Guitar Electronics

DRAWN:
 Dolf Koch

DATE:
 jan 1997

TWINTONE

MARK:
 2.0

SERIAL NRS:
 x126 - x300

FX LOOP, REVERB

PAGE:
 2 of 4

V4 - 12AX7
 V5,6 - EL34
 TX1 - TXO-50.1

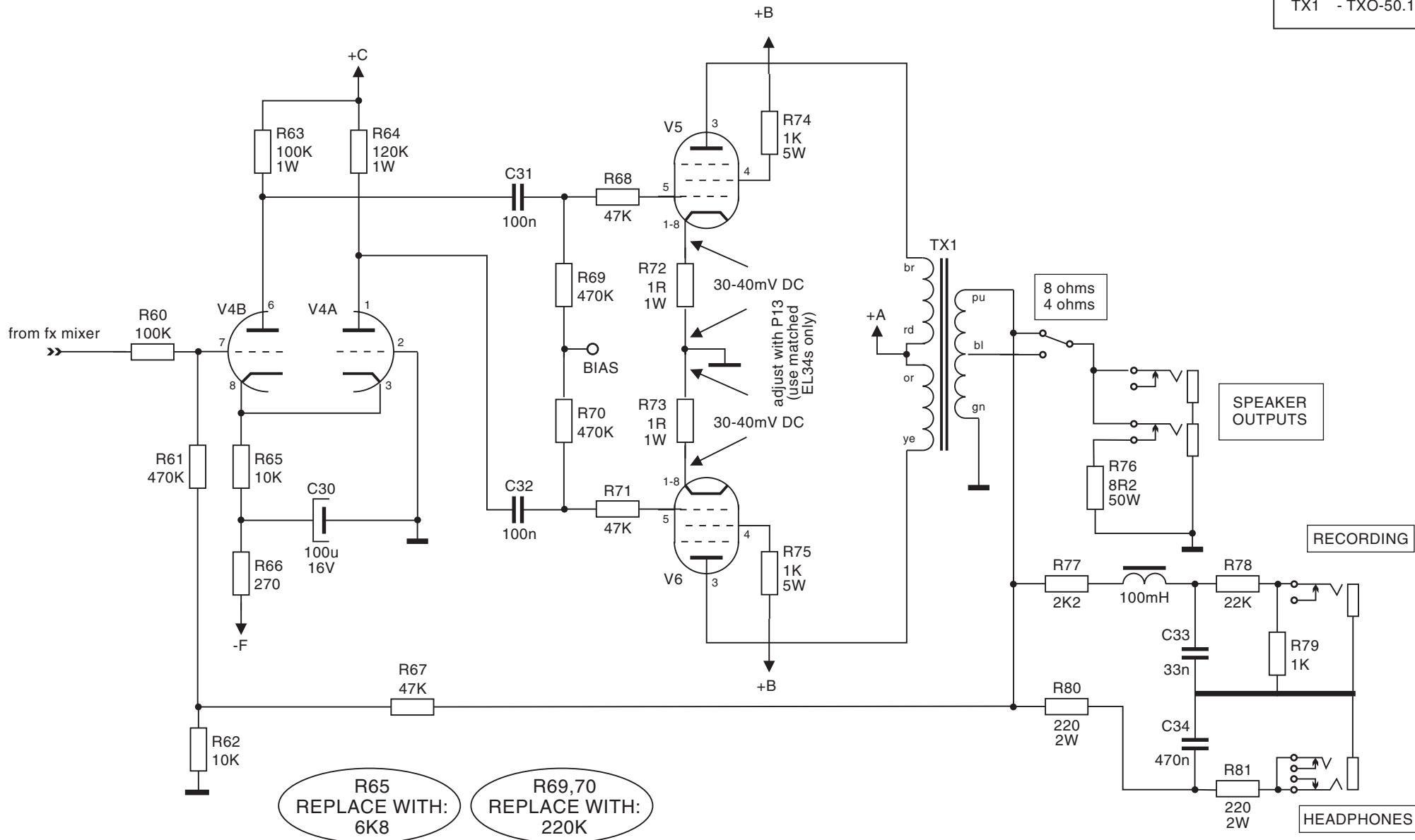

R65
 REPLACE WITH:
 6K8

R69,70
 REPLACE WITH:
 220K

T3,4 - BC550
TX2 - TXM-50.1

