

V1 - 12AX7WA/EH  
V2,3 - 12AX7

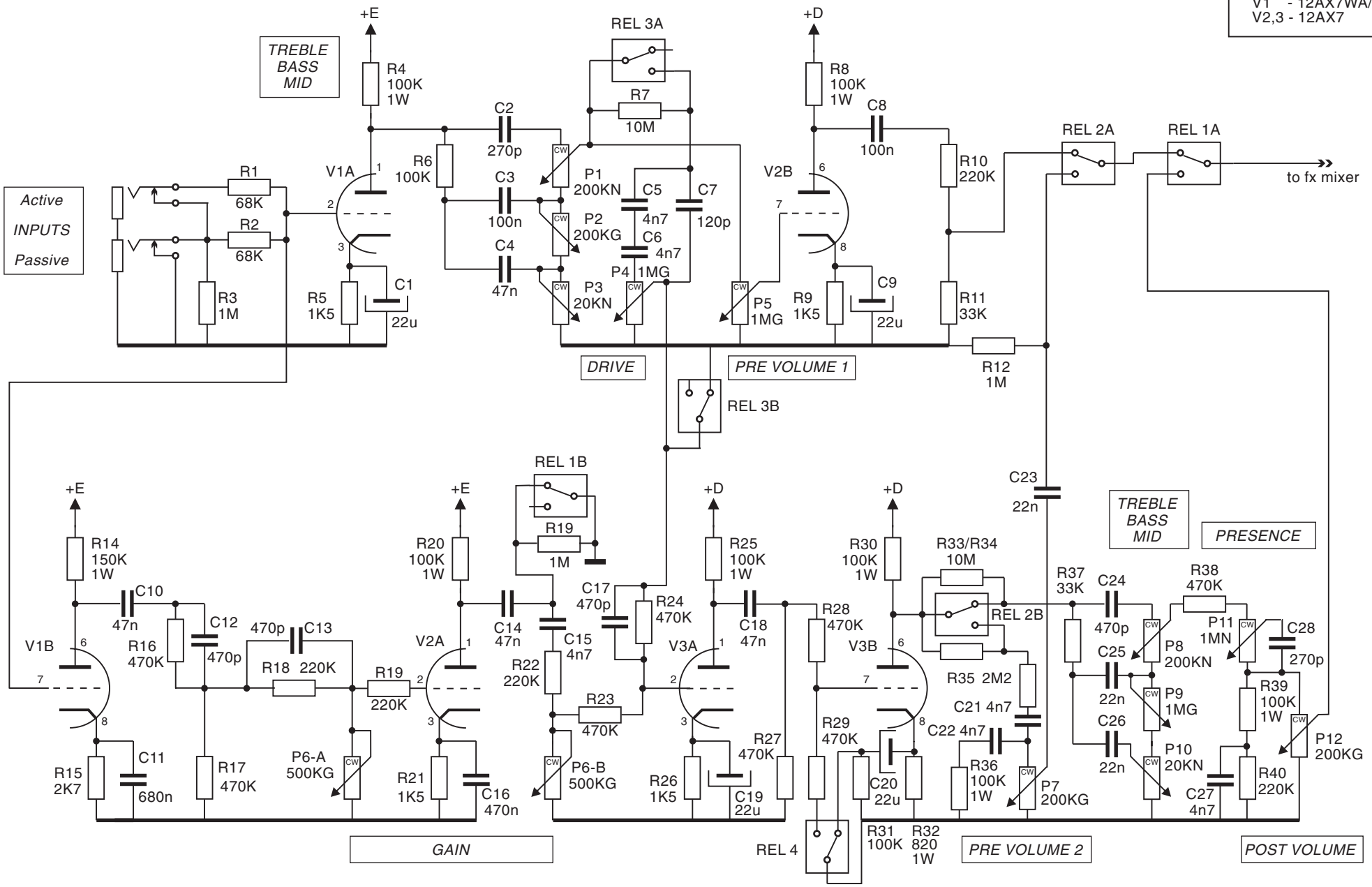

**KOCH**  
**GUITAR ELECTRONICS**  
Amersfoort  
The Netherlands

© Copyright 1996, Koch Guitar Electronics

DRAWN:  
Dolf Koch

DATE:  
may 2001

**MULTITONE**

MARK:  
5.0

SERIAL NRS:  
x501 - x786

PRE-AMP

PAGE:  
1 of 5

- IC1 - OP249
- IC2 - TL071
- IC3 - TL061
- T1 - BD136
- T2 - BD135

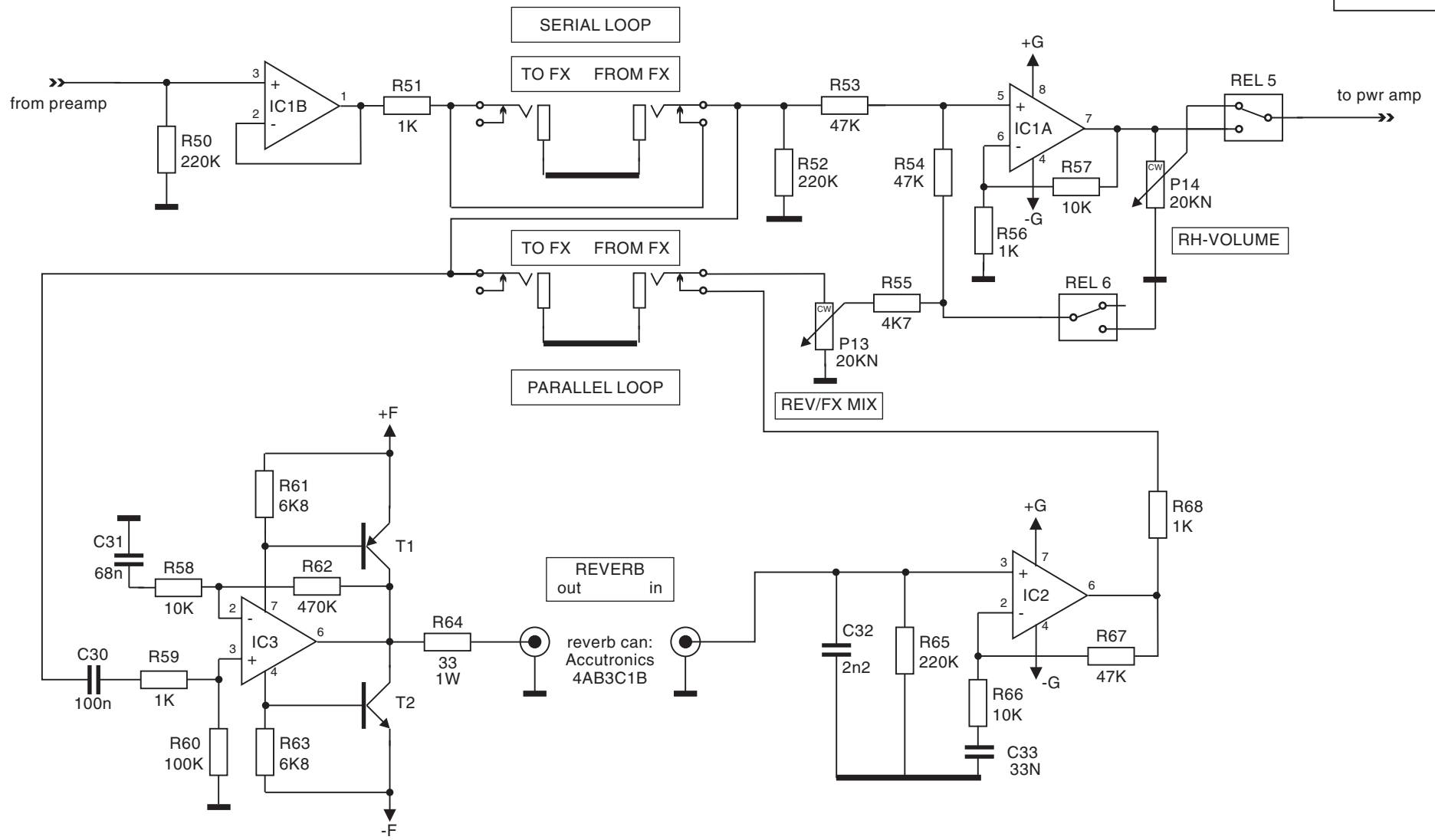

**KOCH**  
**GUITAR ELECTRONICS**  
 Amersfoort  
 The Netherlands

© Copyright 1996, Koch Guitar Electronics

DRAWN:  
Dolf Koch

DATE:  
may 2001

**MULTITONE**

MARK:  
5.0

SERIAL NRS:  
x501 - x786

FX MIXER

PAGE:  
2 of 5

V4 - 12AX7  
 V5-8 - 50W : 2xEL34 / 4x6V6  
           100W: EL34/6L6/6550  
 TX1 - 50W : TXO-50.1  
       100W: TXO-100.1

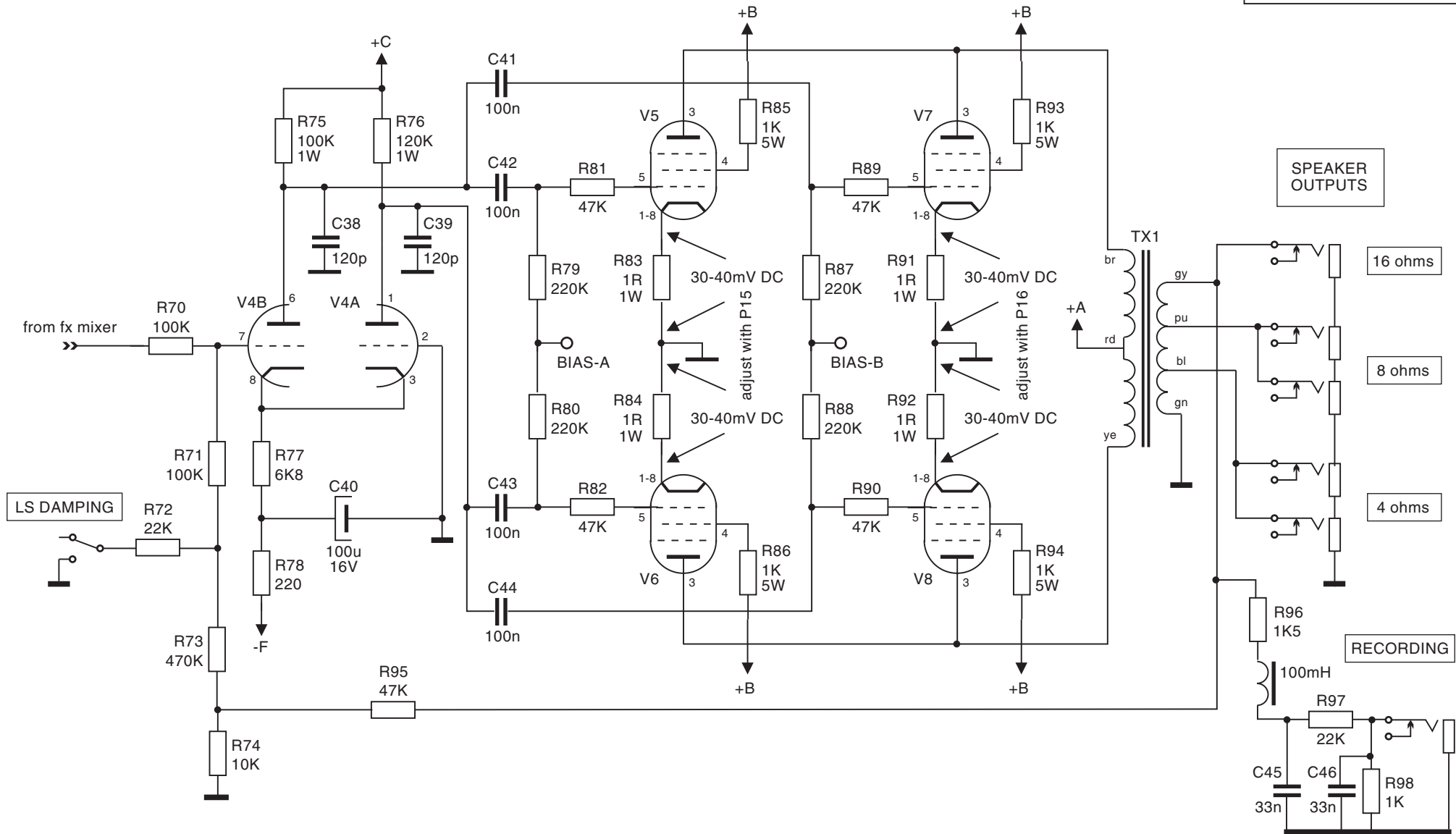

**KOCH**  
**GUITAR ELECTRONICS**  
 Amersfoort  
 The Netherlands

© Copyright 1996, Koch Guitar Electronics

DRAWN:  
 Dolf Koch

DATE:  
 may 2001

**MULTITONE**

MARK:  
 5.0

SERIAL NRS:  
 x501 - x786

POWER AMP

PAGE:  
 3 of 5

T3 = BC550  
 IC4 = MC33204P  
 REL1-6 = 12VDC, DPDT

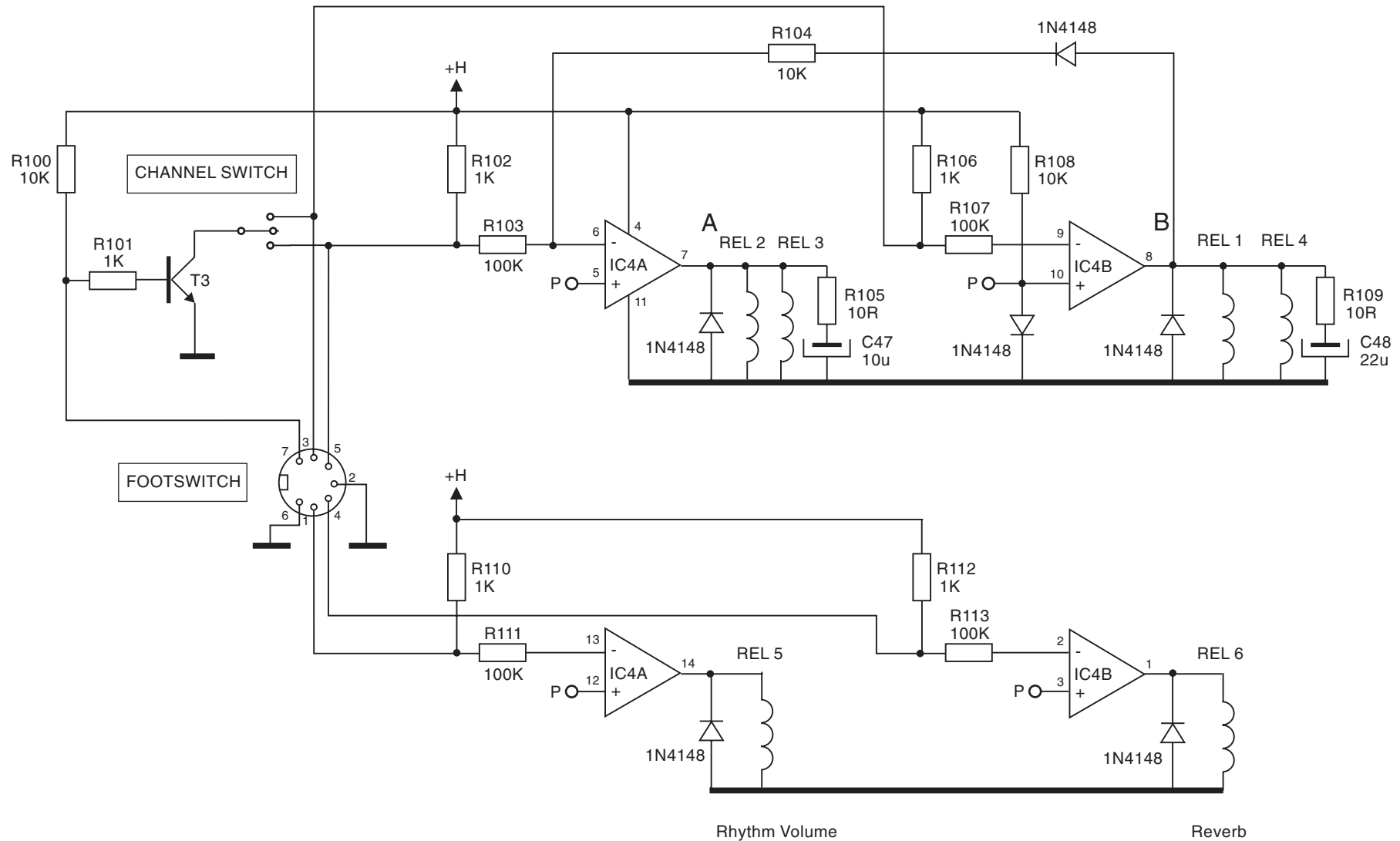

**KOCH**  
**GUITAR ELECTRONICS**  
 Amersfoort  
 The Netherlands

© Copyright 1996, Koch Guitar Electronics

DRAWN:  
 Dolf Koch

DATE:  
 may 2001

**MULTITONE**

MARK:  
 5.0

SERIAL NRS:  
 x501 - x786

LOGIC

PAGE:  
 4 of 5

TX2 - 50W : TXM-50.3  
 100W : TXM-100.3

