

ECOs INCLUDED ON THIS SCHEMATIC/PCB REVISION		
ECO NO:	DATE:	DESCRIPTION:

3.5mm STEREO INPUT

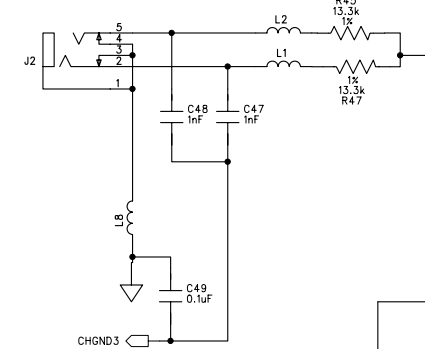

THE INFORMATION CONTAINED IN THIS DRAWING IS THE SOLE PROPERTY OF LINE 6 INC. ANY REPRODUCTION IN PART OR WHOLE WITHOUT THE WRITTEN PERMISSION OF LINE 6 INC. IS PROHIBITED

COMPANY: LINE 6		REV: A
TITLE: GUITAR IN / CODEC SPIDER2-1508/3012 STEELHEAD		
PROGRAM: PADS POWER LOGIC V5.0		SCALE: 1:1 SIZE: C PART NUMBER: 35-00-0029 SHEET: 1 OF 4
FILENAME:		

DRAWN: T. BURTON	DATED: 4/14/03
CHECKED:	DATED:

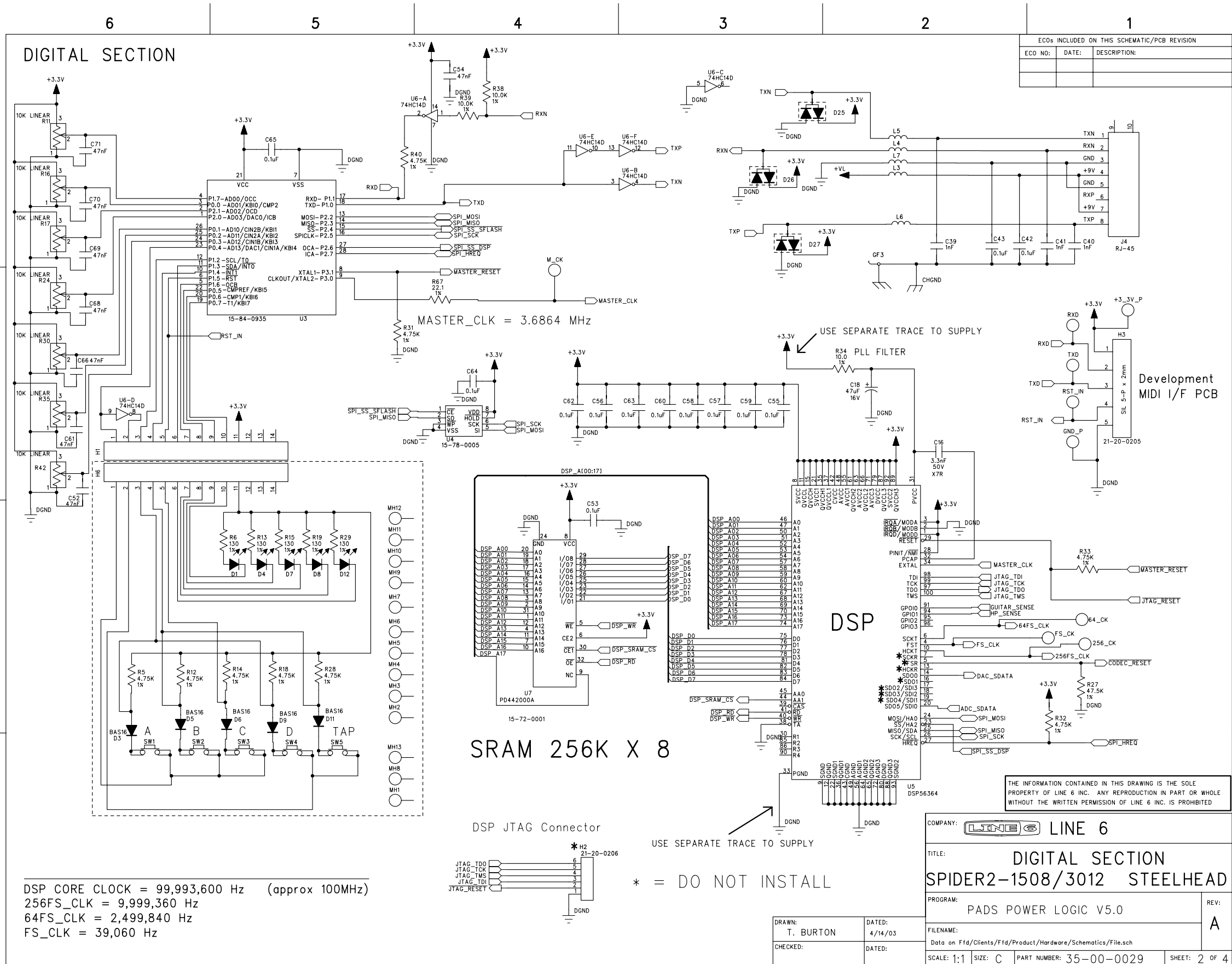

ECOs INCLUDED ON THIS SCHEMATIC/PCB REVISION		
ECO NO:	DATE:	DESCRIPTION:

DIGITAL SECTION

DSP CORE CLOCK = 99,993,600 Hz (approx 100MHz)
 256FS_CLK = 9,999,360 Hz
 64FS_CLK = 2,499,840 Hz
 FS_CLK = 39,060 Hz

SRAM 256K X 8

DSP JTAG Connector

USE SEPARATE TRACE TO SUPPLY

* = DO NOT INSTALL

THE INFORMATION CONTAINED IN THIS DRAWING IS THE SOLE PROPERTY OF LINE 6 INC. ANY REPRODUCTION IN PART OR WHOLE WITHOUT THE WRITTEN PERMISSION OF LINE 6 INC. IS PROHIBITED

COMPANY: LINE 6	
TITLE: DIGITAL SECTION	
SPIDER2-1508/3012 STEELHEAD	
PROGRAM: PADS POWER LOGIC V5.0	REV: A
DRAWN: T. BURTON	DATED: 4/14/03
CHECKED:	DATED:
SCALE: 1:1	SIZE: C
PART NUMBER: 35-00-0029	SHEET: 2 OF 4

6

5

4

3

2

1

POWER AMP / HEADPHONE AMP

ECOs INCLUDED ON THIS SCHEMATIC/PCB REVISION		
ECO NO:	DATE:	DESCRIPTION:

D

C

B

A

D

C

B

A

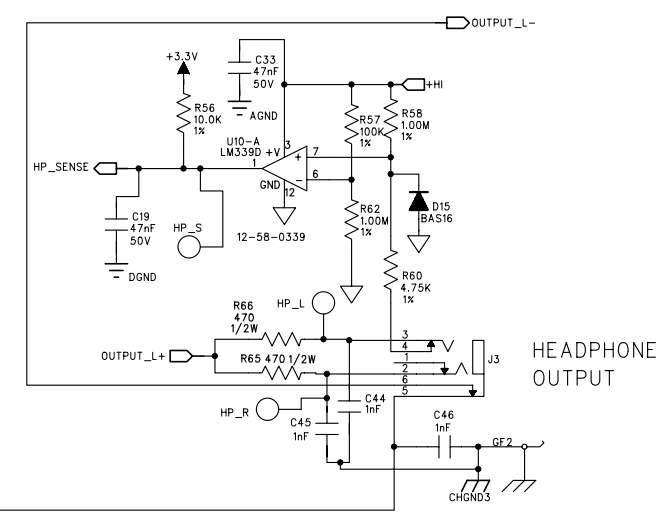
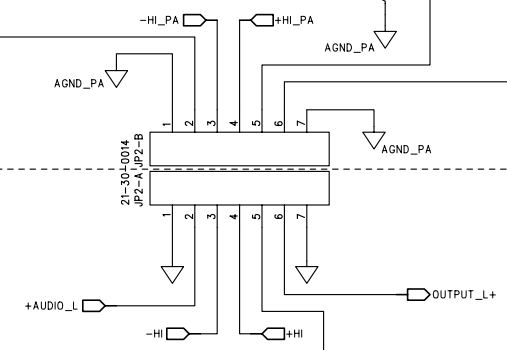
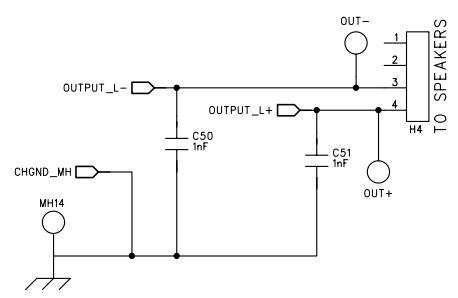
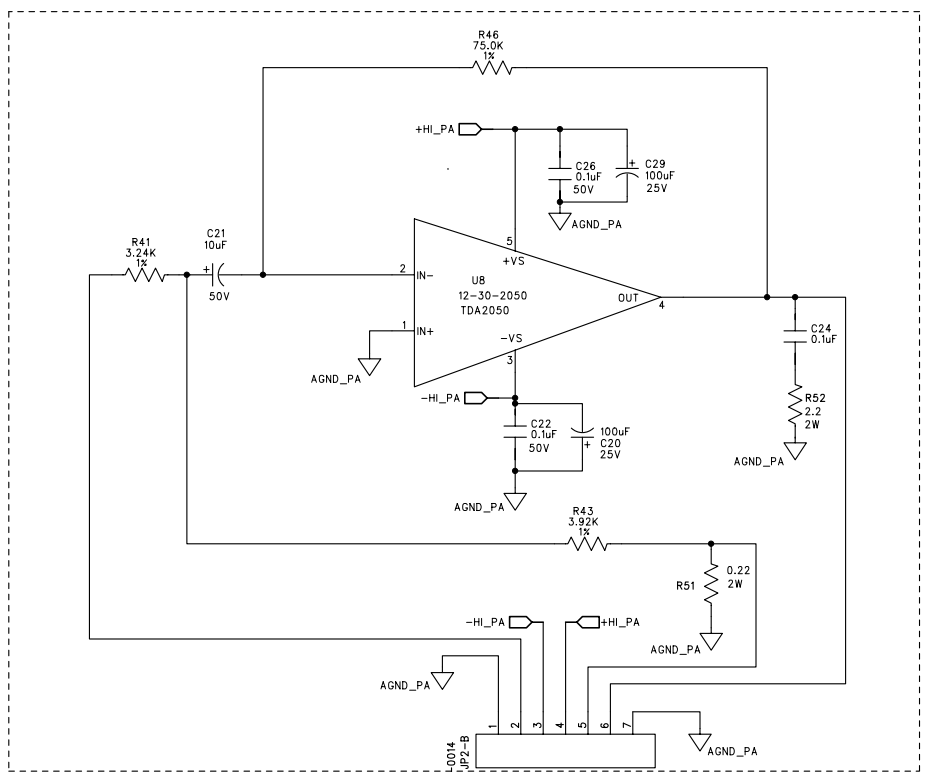

HEADPHONE OUTPUT

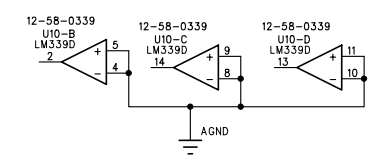

MH15

THE INFORMATION CONTAINED IN THIS DRAWING IS THE SOLE PROPERTY OF LINE 6 INC. ANY REPRODUCTION IN PART OR WHOLE WITHOUT THE WRITTEN PERMISSION OF LINE 6 INC. IS PROHIBITED.

COMPANY: **LINE 6**

TITLE: **SPIDER2-1508/3012 STEELHEAD POWER AMP / HEADPHONE AMP**

PROGRAM: **PADS POWER LOGIC V5.0**

DRAWN: T. BURTON
CHECKED:

DATED: 4/14/03
DATE:

FILENAME: G:/CLIENTS/FFD/Steelhead

SCALE: 1:1 SIZE: C PART NUMBER: 35-00-0029

REV: A

SHEET: 3 OF 4

6 5 4 3 2 1

POWER SUPPLY

ECOs INCLUDED ON THIS SCHEMATIC/PCB REVISION		
ECO NO:	DATE:	DESCRIPTION:

D
C
B
A

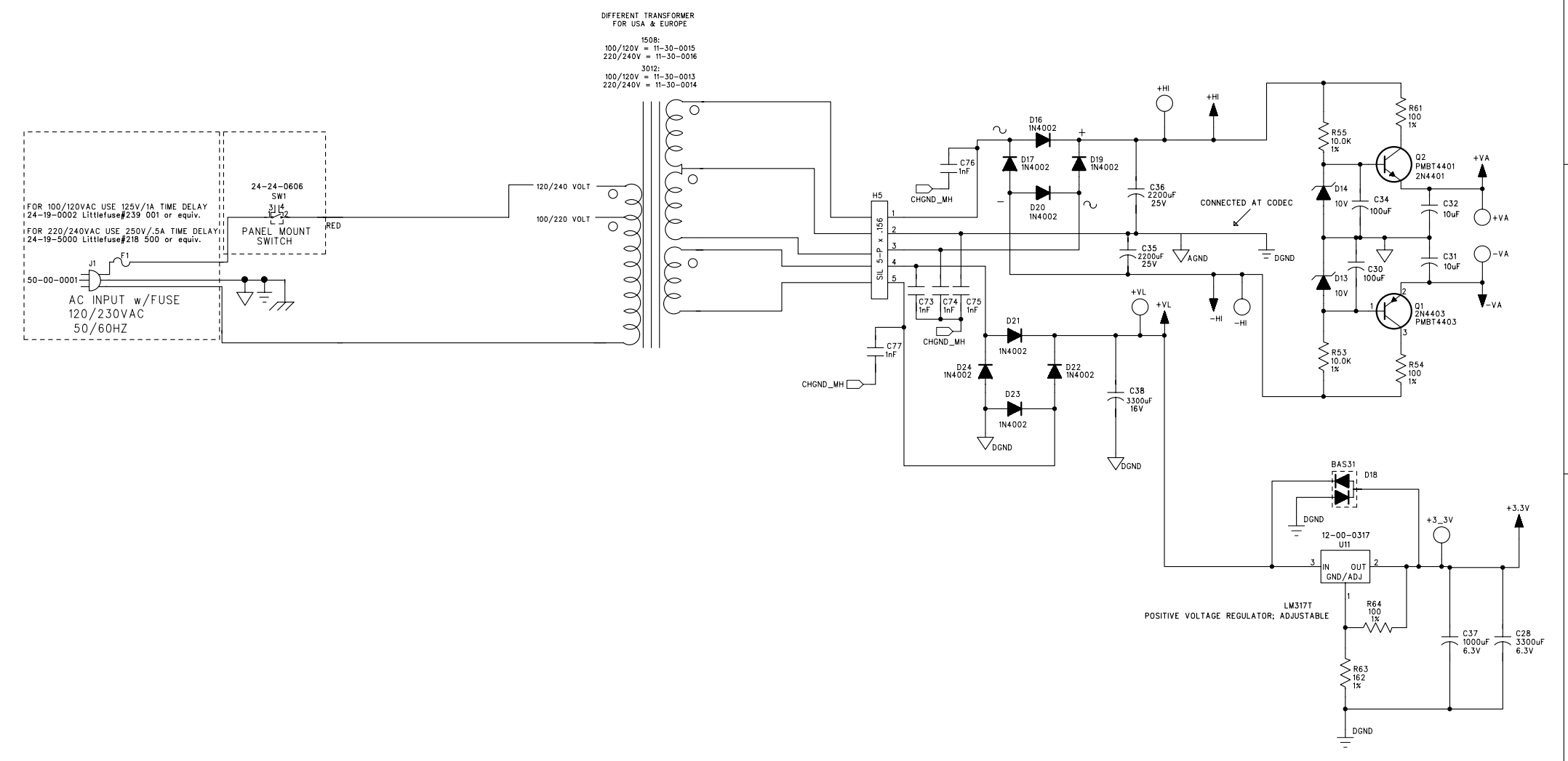

DIFFERENT TRANSFORMER
FOR USA & EUROPE

1508:
100/120V = 11-30-0015
220/240V = 11-30-0016

3012:
100/120V = 11-30-0013
220/240V = 11-30-0014

FOR 100/120VAC USE 125V/1A TIME DELAY
24-19-0002 Littelfuse#239 001 or equiv.

FOR 220/240VAC USE 250V/.5A TIME DELAY
24-19-5000 Littelfuse#218 500 or equiv.

AC INPUT w/FUSE
120/230VAC
50/60HZ

24-24-0606
SW1

PANEL MOUNT
SWITCH

THE INFORMATION CONTAINED IN THIS DRAWING IS THE SOLE
PROPERTY OF LINE 6 INC. ANY REPRODUCTION IN PART OR WHOLE
WITHOUT THE WRITTEN PERMISSION OF LINE 6 INC. IS PROHIBITED

COMPANY:	LINE 6
TITLE:	SPIDER2-1508/3012 STEELHEAD POWER SUPPLY
PROGRAM:	PADS POWER LOGIC V5.0
FILENAME:	G:/CLIENTS/FFD/Steelhead/
SCALE:	1:1
SIZE:	C
PART NUMBER:	35-00-0029
SHEET:	4 OF 4

DRAWN:	T. BURTON	DATED:	4/14/03
CHECKED:		DATED:	

REV: A



Engineering

CONFIDENTIAL

Spider II 3012/1508 Theory of Operation

August 29, 2004

-Guitar input section-

Analog signal consideration:

An analog signal is input through jack J5, and is referenced to ground by R1 which establishes a 1Meg Ohm input impedance. Maximum input signal amplitude before clipping is about 5Vpp(0 to 200Hz).

The signal then passes to U1-A, where the signal is buffered, and also amplified by the pre-emphasis filter in the feedback loop (R3 R4 and C1) This single-pole pre-emphasis filter adds gain starting around 200Hz. Maximum gain is about 8dB at 20kHz.

The output of U1-A is the “low gain” analog signal and is sent to the left input of the CODEC U2. It is also sent to the input of U1-B.

U1-B increases the “low gain” signal by a gain of 16, and this resulting “high gain” signal is then sent to the Right channel of the CODEC U2.

Digital signal consideration:

The GUITAR_SENSE’ signal, which is sent to the DSP, indicates the presence of a jack plugged into J1. This signal is created by: J1 and the pull-up resistor R37. The signal is low if there is no jack, and high if a jack is plugged in.

EMI consideration:

C72 and GF1 help to shunt HF noise to the chassis and AGND’ appropriately.

ESD consideration:

D2 is a voltage clamp, and helps insure that ESD will not exceed the voltage rails of U1. R2 provides over-voltage current limiting for both D5 and U14.

-Signal Processing Section-

Analog signal consideration:

Inputs to ADC:

The “high gain” and “low gain” analog signals arrive at the CODEC from the Guitar In Section. The series capacitors on each input are used as “DC blocking” capacitors since the analog inputs of U2 are biased to approximately ½ of it’s analog supply, or 1.5V. On the right channel “high gain” input to U2, a diode D10 is used to “clamp” the voltage to a safe level (-0.6V and +3VA+0.6V) since this channel is usually clipping with a nominal signal present at the input.

The ADC of U2 converts the left and right analog signals into digital signals, which are then sent to the DSP (ADC_DATA) for processing. Only one of the signals is chosen based on amplitude, before it is processed. The processing includes a digital de-emphasis filter to compliment the analog pre-emphasis filter.

Outputs of DAC:

The codec receives the processed digital audio signal from the DSP at its serial data input (DAC_DATA). The codec then converts the digital signal into analog signals, which are output on pins 15-16 of U2.

The analog outputs of codec U13 are differential, and have a DC bias of approximately $\frac{1}{2}$ +3.3VA (about 1.5V). C14-15 are used as DC blocking caps. The output signals are summed in order to gain 3dB of noise performance because our system is mono for this product. The signal then is passed to U9-A, which is configured as a low-pass filter with gain of around 4.1. The frequency cutoff for the LPF is well above the audio pass-band. ($f_c > 20\text{kHz}$) and is intended to reduce EMI. The resulting output of U9A (+AUDIO_L) is single-ended, and in-phase with the system's input. J2 is configured as an auxiliary CD/MP3 input. The L/R signals are summed mono via R45 and R47 and mixed with our CODEC output at U9-A. U9-B is configured as a buffer between the master volume and the power amp input.

Digital signal consideration:

System reset is provided internally by the MCU. The MCU provides system control and ADC for all of the front panel potentiometers. The DSP U5 provides processing of the audio signals.

Clocks:

The 3.6864MHz system master clock is composed of the components connected to pin 55 (EXTAL) of U7. All other clocks are generated from the master clock within U5, using a PLL. The filter for the PLL is made up of the components connected to pins 31 and 32 of U7.

CODEC clocks:

The codec clocks are generated by U5. Since the system sampling frequency (f_s) is 39.0625 kHz, this is the frequency of the LRCLK. BCLK is the bit clock and runs at a speed of 64fs, or 2.5MHz. Finally, the codec master clock, or MCLK, runs at 256fs, or 10MHz.

Memories:

There is one SRAM connected to the DSP. The SRAM U7 is used for buffering processed audio signals.

FBV: The floorboard signals are buffered through U6. The signals are serial differential output and single ended input. Diodes D25-27 provide ESD/over-voltage protection for U6.

LEDS: The MCU pulls the cathode of an LED on the U.I. low to turn it on. Resistors R6,13,15,19,29 limit current to the LEDS.

JTAG: The JTAG port of the DSP is available through the uninstalled H2 header. This connection is used for development and in-house software upgrades.

Midi/Development I/O: H3 is used to interface with the MCU for development and programming.

Control/sense lines:

HP_SENSE: Is an active high signal, which indicates if a jack has been plugged into the headphone jack.

GUITAR_SENSE: See Guitar In Section above.

-Power Amplifier Section-

Analog signal consideration:

Power amp:

The +AUDIO_L signal travels to the Power Amplifier PCBA and is input to the Power Amplifier IC U8 at pin 2. The power amp topology is set up as a current feedback system to provide a more tube like response to the user. R51 is used as a current sense resistor and feeds back signal into the input. C24 and R52 form an RC network to help suppress oscillation. The ground of the speaker output is connected to the headphone jack so that the speaker is disconnected when headphones are installed.

Headphone output and Headphone Sense:

R65 and 66 reduce the output of the power amp to a level more suitable for headphones. C44-46 act as high frequency shunts to chassis ground for EMI. Comparator U10 is needed to sense when headphones are installed because the pin configuration of our jack doesn't work for this application. The reference voltage of U10 is set by R57 and R62. Normally the voltage at pin 7 is kept lower than pin 6 by the power amp. This keeps the output of the CODEC low. D15 is used to keep negative voltages from damaging U10. Once headphones are installed, pin 4 of J3 is left floating which allows the voltage at pin 7 to rise above pin 6. This causes the output of the comparator to go high and the DSP senses this. The DSP then turns on speaker simulation for the headphones.

-Power Supply Section-

+3.3V is produced by U11, an adjustable voltage regulator. The output of U11 is determined by the two resistors R63 and R64. D18 provides over-voltage and under-voltage protection, while C37 provides filtering.

+VL is used to supply an optional foot controller on the 3012.

+/-HI is provided by the bridge rectifier formed by D16-17,19-20 and filtered by C35 and C36. This voltage feeds the power amp directly.

+/-VA are regulated to approx +/-9V by Q1 and Q2. These transistors act as discrete regulators because their base is biased by 10V zeners D14 and D13. R54 and R61 provide some level of over current protection. C30 and C34 are used as a time constant in conjunction with R53 and R55 in order to ramp up +/- VA slowly at system start up. This minimizes turn on pop at the speaker output.

99-010-1705 Spider II 30 120v Packout

Part Number	Description	Qty Per	Reference Designator(s)
40-00-0053	MANUAL USER UNIVERSAL SPIDER2-1508/3012/A3	1	PACK-OUT.
40-00-1000	CARD WARRANTY LINE 6 HARDWARE	1	PACKOUT
40-03-2000-1	CARD REGISTRATION EUROPE	1	PACKOUT
40-25-0101	LABEL BAR CODE S/N 2-PNL LTX 16 1125502	2	
59-00-0002-2	ASSY UNIT COMPLETE 120V SPIDER2-3012	1	

59-00-0002-2 ASSY UNIT COMPLETE 120V SPIDER2-3012

Part Number	Description	Qty Per	Reference Designator(s)
11-20-0006	SPEAKER 12" 4-OHM 50W CH-CONE CELESTION G12E-50 T5400	1	
11-30-0013	XFMR 100/120VAC 16.5VAC x 2 / 7.2VAC SPIDER2-3012	1	
21-34-0055	CBL ASSY 2 PIN 8.0 IN LG	1	H4 Main PCBA to Speaker.
21-37-0001-1	CBL POWER US/JA 10A/250V 6-FT 18AWG AC-PLUG to CRIMP-TERM x3	1	
24-19-0002	FUSE 1A/250V 5x20mm FRN T Littlefuse H239 001 or equiv.	1	
24-24-0606	SWITCH POWER ROCKER 6A/250VAC 10A/120VAC PNL-MNT BLK	1	
30-00-0033	SCREW 10-24 x7/8 TRUSS HD PHH BLK	4	Speaker Mounting.
30-00-0043	SCREW 6-32 x 5/16 w/LK WASH PPZ STL	2	(1)Main PCBA,(1)Ground Wire Terminal.
30-00-0375	SCREW 6-32 x .375 PPB	3	Screws Used for Switch PCBA.
30-00-0402	SCREW #4 x 1/2IN SEMS w/EXT. TOOTH WASHER STL/ZNC	1	Power Amp IC to Chassis.
30-00-1020	SCREW 10-24 x 1-1/4 OVAL CTSKPB STL	4	Chassis to Cabinet.
30-00-1033	SCREW 10-32 x 3/8IN SCH STL BLK OXIDE	4	Screws secure Front Panel to Chassis.
30-03-0112	WASHER FINISHING #10 FLANGED STL BLK OXIDE	4	Chassis to Cabinet.
30-03-0400	WASHER #4 SPLIT LOCKWASHER ZINC	1	Power Amp to Chassis.
30-03-0425	WASHER #4 0.125" ID x .233" OD.018 HEIGHT ZINC PLATE	1	Power Amp to Chassis.
30-06-0440	NUT HEX .242 4-40 STL/ZNC	1	Power Amp IC.
30-06-0832	NUT .335 HEX 8-32 STL ZINC W/ TOOTH WASHER	4	Transformer to Chassis.
30-15-0404	SHOULDER BUSHING TO-220 VALPAKNY04-040-140-012TWG	1	Power Amp IC.
30-24-0003	CABLE-TIE 4" CLEAR	3	(1)AC Wire,(1)Speaker Programming Cable, Ref Step#19 in MAI.
30-27-0104	PANEL U/I 16.69 x 3.83-IN ABS GREY SPIDER2-3012	1	
30-45-0011	KNOB POT .77 DIA x .76 HT PLASTIC CHROME-PLATED	8	
30-51-0174	CHASSIS 5.9 x 3.3 x 16.69 16AWG AL SPIDER2-3012	1	
30-51-0219	U-NUT 10-24 BLK PHOSPHATE	4	Chassis to Cabinet.
30-63-1325	FOAM W/ADH. 13.25" x 0.25" x 0.06" VOLARAPOLELEFIN	2	Chassis Top.
30-63-1550	FOAM W/ADH. 15.50" x 0.25" x 0.06" VOLARAPOLELEFIN	2	Chassis Front.
30-63-4003	PAD THERMAL TO-220 TYPE:K6 BERG K6AC-58	1	Power Amp to Chassis.
30-75-0020	KEYPAD RUBBER 6.74 x .57 x0.23BLK SPIDER2-3012/1508/A3-1	1	
30-75-0021	STRAIN RELIEF BUSHING 13.5MM x12MM	1	AC Cable.
30-75-9600	GROMMET RUBBER 7/16-D x 1/16-GRV x 3/4" GRV-DIA BLK	1	Speaker Wire.
40-25-0018	STICKER LINE6 LOGO OVAL 109.5x28.5mm EPOXY CLEAR	1	
40-25-0030	LABEL ETL KWANASIA 2"x 1"	1	
40-25-0057	LABEL SPEAKER 12-IN 4-OHM CELESTION G12E-50 (11-20-0006)	1	
50-02-0040	PCBA PANELIZED MAIN/SW/PA SPIDER2-3012	1	
50-03-0013	ASSY CABINET SPIDER2-3012	1	

50-02-0040 PCBA PANELIZED MAIN/SW/PA SPIDER2-3012

Part Number	Description	Qty Per	Reference Designator(s)
50-02-0029	PCBA MAIN SPIDER2-3012	1	
50-02-0038	PCBA USER-INTERFACE SPIDER2- 1508/3012	1	
50-02-0039	PCBA POWER-AMP SPIDER2-3012	1	

50-02-0029 PCBA MAIN SPIDER2-3012

Part Number	Description	Qty Per	Reference Designator(s)
01-16-0471	RES CARBON FILM 470R 1/2W 5% TH	2	R65, R66.
01-24-1000	RES 100R 1% 0805	3	R54, R61, R64.
01-24-1001	RES 1.00K 1% 0805	2	R2, R8.
01-24-1002	RES 10.0K 1% 0805	5	R38, R39, R53, R55, R56.
01-24-1003	RES 100K 1% 0805	1	R57.
01-24-1004	RES 1.00M 1% 0805	3	R1, R58, R62.
01-24-10R0	RES 10.0R 1% 0805	1	R34.
01-24-1332	RES 13.3K 1% 0805	4	R45, R47, R48, R49.
01-24-1502	RES 15.0K 1% 0805	1	R7.
01-24-1620	RES 162R 1% 0805	1	R63.
01-24-1912	RES 19.1K 1% 0805	2	R22, R23.
01-24-2002	RES 20.0K 1% 0805	2	R20, R21.
01-24-2211	RES 2.21K 1% 0805	1	R4.
01-24-22R1	RES 22.1R 1% 0805	3	R9, R10, R67.
01-24-3321	RES 3.32K 1% 0805	1	R3.
01-24-4751	RES 4.75K 1% 0805	7	R31, R32, R33, R36, R37, R40, R60.
01-24-4752	RES 47.5K 1% 0805	1	R27.
01-24-5492	RES 54.9K 1% 0805	1	R44.
01-24-5R11	RES 5.11R 1% 0805	2	R25, R26.
01-48-0001	POT MONO CTR-DTNT10KB LINEAR 9mm/20mm SHFT 18-TH KNURLD HOR	8	R11, R16, R17, R24, R30, R35, R42, R59.
03-10-0106	CAP ELEC 10uF 10V 20% RADIAL 5/11/5	4	C4, C5, C10, C12.
03-10-0338	CAP ELEC 3300uF 6.3V 20% RADIAL 10/20/5	1	C28.
03-10-6108	CAP ELEC 1000uF 6.3V 20% RADIAL 8/11.5/5	2	C8, C37.
03-12-0107	CAP ELEC 100uF 16V 20% RADIAL 6.3/11/5	2	C30, C34.
03-12-0476	CAP ELEC 47uF 16V 20% RADIAL 6.3/11.2/5	1	C18.
03-12-1338	CAP ELEC 3300uF 16V 20% RADIAL12.5/25/5	1	C38.
03-14-0228	CAP ELEC 2200uF 25V 20% RADIAL 12.5/25/5	2	C35, C36.
03-18-0105	CAP ELEC 1uF 50V 20% RADIAL 5/11/5	4	C6, C7, C14, C15.
03-18-0106	CAP ELEC 10uF 50V 20% RADIAL 5/11/5	2	C31, C32.
03-24-0273	CAP MET-POLY 27nF 50V 5% TH 7.3/3.2/5/5	1	C1.
03-50-0270	CAP NPO 27pF 50V 5% 0805	1	C23.
03-52-0102	CAP X7R 1nF 50V 10% 0805	15	C39, C40, C41, C44, C45, C46, C47, C48, C50, C51, C73, C74, C75, C76, C77.
03-52-0104	CAP X7R 0.1uF 50V 10% 0805	17	C9,C11,C13,C42,C43,C49,C53,C55-C60,C62-C65.
03-52-0332	CAP X7R 3.3nF 50V 10% 0805	1	C16.
03-52-0470	CAP X7R 47pF 50V 10% 0805	1	C72.

50-02-0029 PCBA MAIN SPIDER2-3012

Part Number	Description	Qty Per	Reference Designator(s)
03-52-0473	CAP X7R 47nF 50V 10% 0805	16	C71.
06-04-4002	DIODE SMALL-SIGNAL 100V 30A DO-41 AXIAL TH 1N4002	8	D16, D17, D19, D20, D21, D22, D23, D24.
06-23-0054	DIODE SCHOTTKY DUAL 30V 200mA 5nS SOT-23 SM BAT54S	1	D10.
06-28-8410	DIODE ZENER 10V 5% 350mW SOT-23 SM BZX84C10	2	D13, D14.
06-34-0016	DIODE SWITCHING 75V 200mA 6nS SOT-23 SM BAS16LT1	1	D15.
06-34-0031	DIODE GEN PUR DUAL 120V 600mA 50nS SOT-23 SM BAS31	5	D2, D18, D25, D26, D27.
09-10-4401	TRANS NPN SMALL-SIGNAL MBT4401SOT-23 SM	1	Q2.
09-10-4403	TRANS PNP SMALL-SIGNAL MBT4403SOT-23 SM	1	Q1.
11-10-2012	FERRITE BEAD 600R@100MHZ 300mA 0805 SM	10	L1, L2, L3, L4, L5, L6, L7, L8, L9, L10.
12-00-0317	IC VREG ADJ 1.2-37V 1.5 AMP TO-220 LM317 TH	1	U11.
12-54-0072	IC OP-AMP DUAL TL072CD SM	2	U1, U9.
12-58-0339	IC COMPARATOR QUAD LM339D SM	1	U10.
12-64-4552	IC CONVERTER 3V 24B 96KHz AUDIO CODEC SM AK4552	1	U2.
15-62-0014	IC 74HC14 INVERTER HEX SCHMITT TRIGGER SO-14 SM	1	U6.
15-72-0001	IC SRAM-256K x 8 TSOP32 SM	1	U7.
15-86-0364	IC DSP 24-BIT TQFP-100 SM XCB56364FU100	1	U5.
21-00-6616	JACK 1/4" TRS 6-PIN PCB MT HORIZ TH	2	J1, J3.
21-12-0035	JACK 3.5mm STEREO 5 PIN CRIMPED LEADS NON-THREADED	1	J2.
21-16-0045	JACK RJ-45 8-PIN FEMALE PCB-MNT RT-ANG	1	J4.
21-20-1564	HDR SIL PCB-MT 4-PIN X .156 MALE VERT-MNT FRIC-LOCK	1	H4.
21-20-1565	HDR SIL PCB-MT 5-PIN X .156 MALE VERT-MNT FRIC-LOCK	1	H5.
21-30-0014	CBL SIL 7 PIN 2.54 x 76MM 22 AWG S/T	1	JP2-A Main PCB to JP2-B Power Amp.
21-30-0029	CBL DIL 14 PIN .100 PITCH 2.0 IN RIBBON STAKED TO FEMALE	1	H1 To H6.
30-18-3030	CLIP GND PCB .30x.30x.07	3	GF1, GF2, GF3.
30-51-0146	SHIELD PCB MT FOR 1/4 JACK 1.00 Hx1.25Wx.013THK BERYL COP	1	SH1.
35-00-0029	PCB MAIN SPIDER2-3012/1508 REV.A	1	Not Available As A Replacement Part
45-01-0009	IC PROGRAMMED MCU v1.01 c/s= 0xAFD6414D SPIDER2-1508/3012	1	U3.
45-02-0020	IC PROGRAMMED FLASH v1.01 c/s=0x00DFD39D SPIDER2-3012	1	U4.

50-02-0038 PCBA USER-INTERFACE SPIDER2- 1508/3012

Part Number	Description	Qty Per	Reference Designator(s)
01-24-1300	RES 130R 1% 0805	5	R6, R13,R15, R19, R29.
01-24-4751	RES 4.75K 1% 0805	5	R5, R12, R14, R18, R28.
06-34-0016	DIODE SWITCHING 75V 200mA 6nS SOT-23 SM BAS16LT1	5	D3, D5, D6, D9, D11.
18-22-0003	LED YELLOW SUPER 2.0x1.2x1.1mmAP2012SYC SM	5	D1, D4, D7, D8, D12.
21-21-0014	HDR DIL PCB-MT 14-PIN 2x7x.100MALE SHRD VERT MT TH	1	H6.
35-00-0038	PCB SWITCH-BOARD REV.A SPIDER2-3012/1508	1	Not Available As A Replacement Part

50-02-0039 PCBA POWER-AMP SPIDER2-3012

Part Number	Description	Qty Per	Reference Designator(s)
01-20-0R22	RES METAL OXIDE 0.22R 2W 5% THS/B 01-22-0R22	1	R51.
01-22-02R2	RES METAL OXIDE 2.2R 2W 5% TH	1	R52.
01-24-3241	RES 3.24K 1% 0805	1	R41.
01-24-3921	RES 3.92K 1% 0805	1	R43.
01-24-7502	RES 75.0K 1% 0805	1	R46.
03-14-0107	CAP ELEC 100uF 25V 20% RADIAL 6.3/11.2/5	2	C20, C29.
03-18-0106	CAP ELEC 10uF 50V 20% RADIAL 5/11/5	1	C21.
03-52-0104	CAP X7R 0.1uF 50V 10% 0805	3	C22, C24, C26.
12-30-2050	IC POWER-AMP 32W TDA2050V TO-220/5 TH	1	U8.
35-00-0039	PCB POWER-AMP REV.A SPIDER2-3012/1508	1	Not Available As A Replacement Part

50-03-0013 ASSY CABINET SPIDER2-3012

Part Number	Description	Qty Per	Reference Designator(s)
30-00-0812	SCREW w/WAX 8 x 3/4 PTB	14	Corner Screws.
30-00-1024	SCREW 10-24 x 1IN OVAL CTSK PPB STL WAXED	2	Handle.
30-06-1024	NUT-T 10-24 X 5/16 STEEL	6	(4)Speaker, (2)Handle.
30-28-0002	CORNER LEFT HI-DENSITY POLYETHYLENE TEXTURED BLACK	1	
30-28-0003	CORNER RIGHT HI-DENSITY POLYETHYLENE TEXTURED BLACK	1	
30-28-0004	CORNER BACK HI-DENSITY POLYETHYLENE TEXTURED BLACK	6	
30-36-0005	COVER VINYL TEXTURED BLACK SEMI-GLOSS	1	
30-39-0006	GRILL-CLOTH BLACK WEAVE	1	
30-51-0188-2	BRACE BAFFLBOARD 16.55x.90x.69EGS	1	
30-57-0580	HANDLE/STRAP HEAVY DUTY BLACK	1	
30-57-0581	ENDCAPS BLACK TEXTURED FINISH	2	
30-63-0016	FOAM w/ADHSV 8.0 x 1/4 x 1/16 VOLARAPOLELEFIN	4	Add four (4) 203.2MM [8.0 in long foam strips W/ADHSV to front of Baffle board.
30-99-0225	CABINET RAW-WOOD SPIDER2-3012	1	

99-010-1905 SPIDER 1508 US 120V

Part Numbers	Description	Qty Per	Reference Designator(s)
40-00-0053	MANUAL USER UNIVERSAL SPIDER2-1508/3012/A3	1	PACK-OUT.
40-00-1000	CARD WARRANTY LINE 6 HARDWARE	1	PACKOUT
59-00-0003-2	ASSY UNIT COMPLETE 120V SPIDER2-1508	1	

59-00-0003-2 ASSY UNIT COMPLETE 120V SPIDER2-1508

Part Number	Description	Qty Per	Reference Designator(s)
11-20-0003	SPEAKER 8" 4-OHM 15W CHUNIL 200RFL06-3C	1	
11-30-0015	XFMR 100/120VAC 15.2VAC x 2 / 7.2VAC SPIDER2-1508	1	
21-34-0055	CBL ASSY 2 PIN 8.0 IN LG	1	H4 Main PCBA to Speaker.
21-37-0001-1	CBL POWER US/JA 10A/250V 6-FT 18AWG AC-PLUG to CRIMP-TERM x3	1	
24-19-0002	FUSE 1A/250V 5x20mm FRN T Littlefuse H239 001 or equiv.	1	
24-24-0606	SWITCH POWER ROCKER 6A/250VAC 10A/120VAC PNL-MNT BLK	1	
30-00-0033	SCREW 10-24 x7/8 TRUSS HD PHH BLK	4	Speaker Mounting.
30-00-0043	SCREW 6-32 x 5/16 w/LK WASH PPZ STL	2	(1)Main PCBA, (1)Ground Wire Terminal.
30-00-0375	SCREW 6-32 x .375 PPB	3	Screws used for Switch PCBA.
30-00-0402	SCREW #4 x 1/2IN SEMS w/EXT. TOOTH WASHER STL/ZNC	1	Power Amp to Chassis.
30-00-1020	SCREW 10-24 x 1-1/4 OVAL CTSKPB STL	4	Chassis to Cabinet.
30-00-1033	SCREW 10-32 x 3/8IN SCH STL BLK OXIDE	4	Screws secure Front Panel to Chassis.
30-03-0112	WASHER FINISHING #10 FLANGED STL BLK OXIDE	4	Chassis to Cabinet.
30-03-0400	WASHER #4 SPLIT LOCKWASHER ZINC	1	Power Amp IC to Chassis.
30-03-0425	WASHER #4 0.125" ID x .233" OD.018 HEIGHT ZINC PLATE	1	Power Amp to Chassis.
30-06-0440	NUT HEX .242 4-40 STL/ZNC	1	Power Amp IC.
30-06-0832	NUT .335 HEX 8-32 STL ZINC W/ TOOTH WASHER	2	Transformer to Chassis.
30-15-0404	SHOULDER BUSHING TO-220 VALPAKNY04-040-140-012TWG	1	Power Amp IC.
30-24-0003	CABLE-TIE 4" CLEAR	3	(1)AC Wire,(1) Speaker Programming Cable,Ref Step#19 in MAI.
30-27-0103	PANEL U/I 13.94 x 3.83-IN ABS GREY SPIDER2-1508	1	
30-45-0011	KNOB POT .77 DIA x .76 HT PLASTIC CHROME-PLATED	8	
30-51-0175	CHASSIS 5.9 x 3.3 x 13.94 16AWG AL SPIDER2-1508	1	
30-51-0219	U-NUT 10-24 BLK PHOSPHATE	4	Chassis to Cabinet.
30-63-1325	FOAM W/ADH. 13.25" x 0.25" x 0.06" VOLARAPOLELEFIN	2	Chassis Top.
30-63-1550	FOAM W/ADH. 15.50" x 0.25" x 0.06" VOLARAPOLELEFIN	2	Chassis Front.
30-63-4003	PAD THERMAL TO-220 TYPE:K6 BERG K6AC-58	1	Power Amp IC.
30-75-0020	KEYPAD RUBBER 6.74 x .57 x0.23BLK SPIDER2-3012/1508/A3-1	1	
30-75-0021	STRAIN RELIEF BUSHING 13.5MM x12MM	1	AC Cabel.
30-75-9600	GROMMET RUBBER 7/16-D x 1/16-GRV x 3/4" GRV-DIA BLK	1	Speaker Wire.
40-25-0018	STICKER LINE6 LOGO OVAL 109.5x28.5mm EPOXY CLEAR	1	
40-25-0030	LABEL ETL KWANASIA 2" x 1"	1	
50-02-0046	PCBA PANELIZED MAIN/SW/PA SPIDER2-1508	1	
50-03-0015	ASSY CABINET SPIDER2-1508	1	

50-02-0046 PCBA PANELIZED MAIN/SW/PA SPIDER2-1508

Part Number	Description	Qty Per	Reference Designator(s)
50-02-0035	PCBA MAIN SPIDER2-1508	1	
50-02-0038	PCBA USER-INTERFACE SPIDER2- 1508/3012	1	
50-02-0044	PCBA POWER-AMP SPIDER2-1508	1	

50-02-0035 PCBA MAIN SPIDER2-1508

Part Number	Description	Qty Per	Reference Designator(s)
01-16-0471	RES CARBON FILM 470R 1/2W 5% TH	2	R65, R66.
01-24-1000	RES 100R 1% 0805	3	R54, R61, R64.
01-24-1001	RES 1.00K 1% 0805	2	R2, R8.
01-24-1002	RES 10.0K 1% 0805	5	R38, R39, R53, R55, R56.
01-24-1003	RES 100K 1% 0805	1	R57.
01-24-1004	RES 1.00M 1% 0805	3	R1, R58, R62.
01-24-10R0	RES 10.0R 1% 0805	1	R34.
01-24-1332	RES 13.3K 1% 0805	4	R45, R47, R48, R49.
01-24-1502	RES 15.0K 1% 0805	1	R7.
01-24-1620	RES 162R 1% 0805	1	R63.
01-24-1912	RES 19.1K 1% 0805	2	R22, R23.
01-24-2002	RES 20.0K 1% 0805	2	R20, R21.
01-24-2211	RES 2.21K 1% 0805	1	R4.
01-24-22R1	RES 22.1R 1% 0805	3	R9, R10, R67.
01-24-3321	RES 3.32K 1% 0805	1	R3.
01-24-4751	RES 4.75K 1% 0805	7	R31, R32, R33, R36, R37, R40, R60.
01-24-4752	RES 47.5K 1% 0805	1	R27.
01-24-5492	RES 54.9K 1% 0805	1	R44.
01-24-5R11	RES 5.11R 1% 0805	2	R25, R26.
01-48-0001	POT MONO CTR-DTNT10KB LINEAR 9mm/20mm SHFT 18-TH KNURLD HOR	8	R11, R16, R17, R24, R30, R35, R42, R59.
03-10-0106	CAP ELEC 10uF 10V 20% RADIAL 5/11/5	4	C4, C5, C10, C12.
03-10-0338	CAP ELEC 3300uF 6.3V 20% RADIAL 10/20/5	1	C28.
03-10-6108	CAP ELEC 1000uF 6.3V 20% RADIAL 8/11.5/5	2	C8, C37.
03-12-0107	CAP ELEC 100uF 16V 20% RADIAL 6.3/11/5	2	C30, C34.
03-12-0476	CAP ELEC 47uF 16V 20% RADIAL 6.3/11.2/5	1	C18.
03-12-1338	CAP ELEC 3300uF 16V 20% RADIAL 12.5/25/5	1	C38.
03-14-0228	CAP ELEC 2200uF 25V 20% RADIAL 12.5/25/5	2	C35, C36.
03-18-0105	CAP ELEC 1uF 50V 20% RADIAL 5/11/5	4	C6, C7, C14, C15.
03-18-0106	CAP ELEC 10uF 50V 20% RADIAL 5/11/5	2	C31, C32.
03-24-0273	CAP MET-POLY 27nF 50V 5% TH 7.3/3.2/5/5	1	C1.
03-50-0270	CAP NPO 27pF 50V 5% 0805	1	C23.
03-52-0102	CAP X7R 1nF 50V 10% 0805	12	C44, C45, C46, C47, C48, C50, C51, C73, C74, C75, C76, C77.
03-52-0104	CAP X7R 0.1uF 50V 10% 0805	15	C9, C11, C13, C49, C53, C55, C56, C57, C58, C59, C60, C62, C65.
03-52-0332	CAP X7R 3.3nF 50V 10% 0805	1	C16.
03-52-0470	CAP X7R 47pF 50V 10% 0805	1	C72.

50-02-0035 PCBA MAIN SPIDER2-1508

Part Number	Description	Qty Per	Reference Designator(s)
03-52-0473	CAP X7R 47nF 50V 10% 0805	16	C2, C3, C17, C19, C25, C27, C33, C52, C54, C61, C66, C67, C68, C69, C70, C71.
06-04-4002	DIODE SMALL-SIGNAL 100V 30A DO-41 AXIAL TH 1N4002	8	D16, D17, D19, D20, D21, D22, D23, D24.
06-23-0054	DIODE SCHOTTKY DUAL 30V 200mA 5nS SOT-23 SM BAT54S	1	D10.
06-24-8410	DIODE ZENER 10V 5% 350mW SOT-23 SM BZX84C10	2	D13, D14.
06-34-0016	DIODE SWITCHING 75V 200mA 6nS SOT-23 SM BAS16LT1	1	D15.
06-34-0031	DIODE GEN PUR DUAL 120V 600mA 50nS SOT-23 SM BAS31	2	D2, D18.
09-10-4401	TRANS NPN SMALL-SIGNAL MBT4401SOT-23 SM	1	Q2.
09-10-4403	TRANS PNP SMALL-SIGNAL MBT4403SOT-23 SM	1	Q1.
11-10-2012	FERRITE BEAD 600R@100MHZ 300mA 0805 SM	5	L1, L2, L8, L9, L10.
12-00-0317	IC VREG ADJ 1.2-37V 1.5 AMP TO-220 LM317 TH	1	U11.
12-54-0072	IC OP-AMP DUAL TL072CD SM	2	U1, U9.
12-58-0339	IC COMPARATOR QUAD LM339D SM	1	U10.
12-64-4552	IC CONVERTER 3V 24B 96KHz AUDIO CODEC SM AK4552	1	U2.
15-62-0014	IC 74HC14 INVERTER HEX SCHMITT TRIGGER SO-14 SM	1	U6.
15-72-0001	IC SRAM-256K x 8 TSOP32 SM	1	U7.
15-86-0364	IC DSP 24-BIT TQFP-100 SM XCB56364FU100	1	U5.
21-00-6616	JACK 1/4" TRS 6-PIN PCB MT HORIZ TH	2	J1, J3.
21-12-0035	JACK 3.5mm STEREO 5 PIN CRIMPED LEADS NON-THREADED	1	J2.
21-20-1564	HDR SIL PCB-MT 4-PIN X .156 MALE VERT-MNT FRIC-LOCK	1	H4.
21-20-1565	HDR SIL PCB-MT 5-PIN X .156 MALE VERT-MNT FRIC-LOCK	1	H5.
21-30-0014	CBL SIL 7 PIN 2.54 x 76MM 22 AWG S/T	1	JP2-A Main PCB to JP2-B Power Amp.
21-30-0029	CBL DIL 14 PIN .100 PITCH 2.0 IN RIBBON STAKED TO FEMALE	1	H1 To H6.
30-18-3030	CLIP GND PCB .30x.30x.07	2	GF1, GF2.
30-51-0146	SHIELD PCB MT FOR 1/4 JACK 1.00 Hx1.25Wx.013THK BERYL COP	1	SH1.
35-00-0029	PCB MAIN SPIDER2-3012/1508 REV.A	1	Not Available As A Replacement Part
45-01-0009	IC PROGRAMMED MCU v1.01 c/s= 0xAFD6414D SPIDER2-1508/3012	1	U3.
45-02-0019	IC PROGRAMMED FLASH v1.01 c/s=0x00DFF11E SPIDER2-1508	1	U4.

50-02-0038 PCBA USER-INTERFACE SPIDER2- 1508/3012

Part Number	Description	Qty Per	Reference Designator(s)
01-24-1300	RES 130R 1% 0805	5	R6, R13, R15, R19, R29.
01-24-4751	RES 4.75K 1% 0805	5	R5, R12, R14, R18, R28.
06-34-0016	DIODE SWITCHING 75V 200mA 6nS SOT-23 SM BAS16LT1	5	D3, D5, D6, D9, D11.
18-22-0003	LED YELLOW SUPER 2.0x1.2x1.1mmAP2012SYC SM	5	D1, D4, D7, D8, D12.
21-21-0014	HDR DIL PCB-MT 14-PIN 2x7x.100MALE SHRD VERT MT TH	1	H6.
35-00-0038	PCB SWITCH-BOARD REV.A SPIDER2-3012/1508	1	Not Available As A Replacement Part

50-02-0044 PCBA POWER-AMP SPIDER2-1508

Part Number	Description	Qty Per	Reference Designator(s)
01-20-0R22	RES METAL OXIDE 0.22R 2W 5% THS/B 01-22-0R22	1	R51.
01-22-02R2	RES METAL OXIDE 2.2R 2W 5% TH	1	R52.
01-22-02R2	RES METAL OXIDE 2.2R 2W 5% TH	1	R52.
01-24-3241	RES 3.24K 1% 0805	1	R41.
01-24-3921	RES 3.92K 1% 0805	1	R43.
01-24-7502	RES 75.0K 1% 0805	1	R46.
03-14-0107	CAP ELEC 100uF 25V 20% RADIAL 6.3/11.2/5	2	C20, C29.
03-14-0107	CAP ELEC 100uF 25V 20% RADIAL 6.3/11.2/5	2	C20, C29.
03-18-0106	CAP ELEC 10uF 50V 20% RADIAL 5/11/5	1	C21.
03-52-0104	CAP X7R 0.1uF 50V 10% 0805	3	C22, C24, C26.
12-30-2030	IC POWER-AMP 18W TDA2030AV TO-220/5 TH	1	U8.
35-00-0039	PCB POWER-AMP REV.A SPIDER2-3012/1508	1	Not Available As A Replacement Part

50-03-0015 ASSY CABINET SPIDER2-1508

Part Number	Description	Qty Per	Reference Designator(s)
30-00-0812	SCREW w/WAX 8 x 3/4 PTB	14	
30-00-1024	SCREW 10-24 x 1IN OVAL CTSK PPB STL WAXED	2	HANDLES.
30-03-0112	WASHER FINISHING #10 FLANGED STL BLK OXIDE	4	
30-06-1024	NUT-T 10-24 X 5/16 STEEL	6	
30-28-0002	CORNER LEFT HI-DENSITY POLYETHYLENE TEXTURED BLACK	1	
30-28-0003	CORNER RIGHT HI-DENSITY POLYETHYLENE TEXTURED BLACK	1	
30-28-0004	CORNER BACK HI-DENSITY POLYETHYLENE TEXTURED BLACK	6	
30-36-0005	COVER VINYL TEXTURED BLACK SEMI-GLOSS	2.5	(2.5 SQ.FT).
30-39-0006	GRILL-CLOTH BLACK WEAVE	0.8	(.80 SQ.FT).
30-51-0188-1	BRACE BAFFLBOARD 13.8x.90x.69 EGS	1	
30-57-0580	HANDLE/STRAP HEAVY DUTY BLACK	1	
30-57-0581	ENDCAPS BLACK TEXTURED FINISH	2	
30-63-0016	FOAM w/ADHSV 8.0 x 1/4 x 1/16 VOLARAPOLELEFIN	4	Add four (4) 203.2MM [8.0 in long foam strips W/ADHSV to front of Baffle board.
30-99-0224	CABINET RAW-WOOD SPIDER2-1508	1	

Troubleshooting Guide – Spider II 1508/3012

This section outlines some common problems that may be encountered when troubleshooting a Spider II 1508/3012.

1. Test points are provided on the TOP of the PCB for **all power supply voltages**. The test points are labeled accordingly. Verifying these voltages should always be the first step in troubleshooting.
2. The board powers up, the UI is displaying the correct items, the buttons and knobs work, but there is NO AUDIO. First, check the audio input circuitry and make sure audio makes it through the input op-amp U1 all the way to the CODEC U2 inputs. Second, make sure that the CODEC has the appropriate clocks driving it (See section CLOCK SYSTEM above). Third, check the audio path from the output of the CODEC to the power amp and the headphone circuitry. Fourth, check that the signal GUITAR_SENSE is HIGH (HIGH means that a jack is plugged into the Spider II's guitar input.). If this signal is not HIGH then the guitar in jack J5 or the support circuitry for the sense line is faulty. If the system thinks that a plug is not plugged into the guitar jack it will automatically mute the audio. Fifth, the audio is correct all the way to the CODEC and the clocks are correct then it is possible that the DSP or an item on its bus is malfunctioning. At this point check for faulty soldering on the DSP or other items on its bus. Sixth, the audio is correct all the way to the power amp but no audio out of the power amp. The power amp IC may be faulty. You may also want to check that the HP_SENSE line on the MAIN PCBA is not LOW when the jack is plugged in.
3. The board is running but the RJ-45 interface to floorboard (FBV2, FBV2) does not work. Check for faulty soldering on the MCU, IC U3, etc... Check that signals are passing through the buffer/inverter U6 properly. Also, check that signals from the MCU or IC U3 are getting to the RJ45 jack along with the 8V supply rail +VL.
4. The Amp starts up and the LEDs function properly but the version checking doesn't work and No audio passes. The serial flash may not be programmed properly.

Additional Tips:

- ❑ Clearly understand the different AC voltage wiring configurations.
- ❑ Be very careful to fully remove the head mounting screws before re-installing the head in the cabinet to avoid scratching the front panel paint.

CUSTOMER SERVICE

Before contacting the Line 6 Customer Service team, please take the time to look through this publication to see if it can answer your questions. Additional helpful information is on the Support page of the Line 6 web site (www.line6.com), including the searchable FAQTRAQ system which is often the fastest and easiest way to get the answers you need.

Need to talk to an actual human on the Line 6 Customer Service team by phone? Have your serial number handy and take some notes for yourself before you call, so you remember everything you want to ask about. In the USA or Canada, you can contact Line 6 at (818) 575-3600, 8AM to 5PM Monday through Friday (Pacific Time). Outside the USA and Canada, please contact your distributor directly to arrange service. The list of Line 6 distributors is available on the Internet at www.line6.com.

To obtain factory service:

If a member of the Line 6 Customer Service Team determines that your Spider II needs to be sent to Line 6 for service, you will be given a return authorization (RA) number. Products returned without an RA number will be returned to you at your sole expense. Pack the product in its original shipping carton and attach a description of the problem along with your name and a phone number where Line 6 can contact you if necessary. Ship the product insured and freight prepaid to:

Line 6 Customer Service
6033 De Soto Avenue,
Woodland Hills, CA 91367

LINE 6

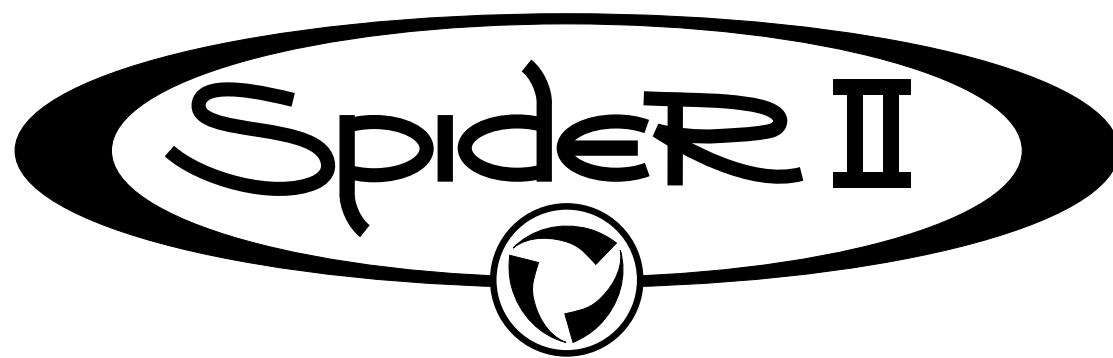

Pilot's Guide for Spider II 15 & 30

40-00-0053 ElectroPhonic Limited Edition available @ www.line6.com Rev A

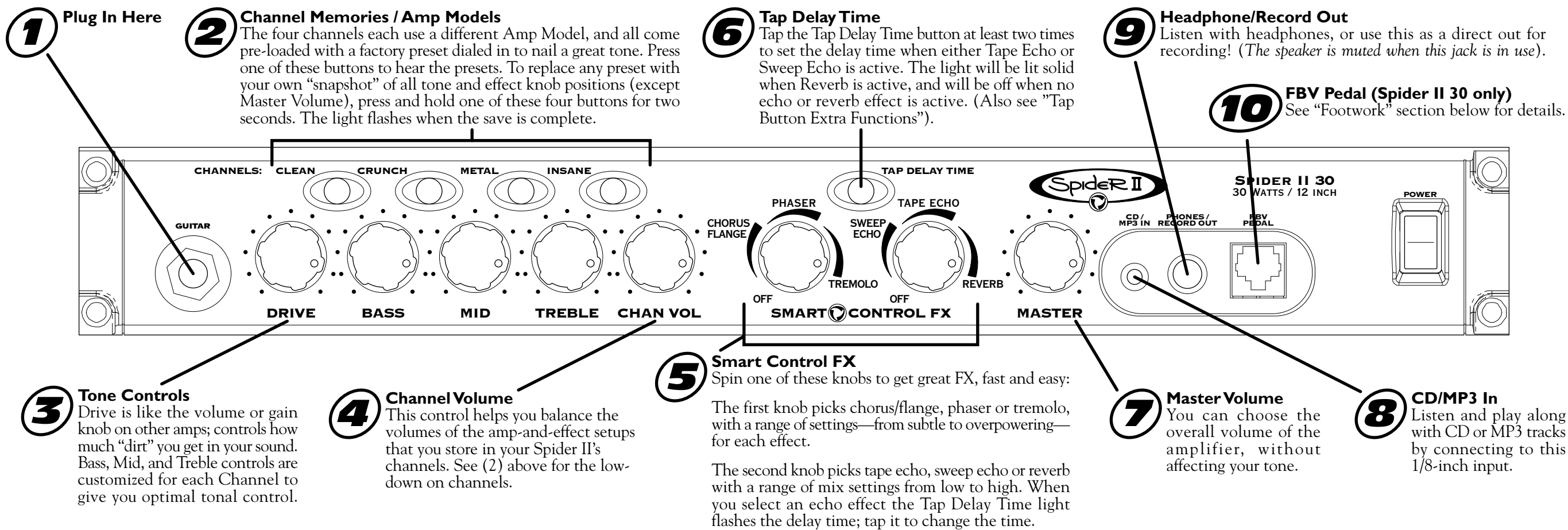

Welcome The Spider II...

Thank you for inviting Spider II home with you. This amp mines the tonal heritage of the past forty years of guitar amplifier design and matches it up with the kind of digital signal processing magic that will still be ahead of its time ten years from now.

Each of the four programmable channels is built on a different Amp Model with its own unique tone:

Clean

Select this Amp Model and adjust the tone controls to get crisp, amazing clean tones, great warm jazz tones, and all the high-end shimmer you'll need with a generous amount of bottom end to boot. Then dial up a little chorus and delay to get the ultimate clean sound!

Crunch

Plexi On Fire! This Amp Model is based on a '68 Marshall Plexi 100 watt with a few added extras; The combination of a Variac and the jumpered input channels creates that infamous brown sound that will feel like flames are shooting out the input jack! "Come on Dave... Give me a break!"

Metal

This Amp Model is based on the Mesa Dual Rectifier. For Spider II, we made careful enhancements to this classic tone. The resulting Amp Model has a definite modern flavor. This monster truck of tone delivers a tight bottom end that's big, powerful, tight and fast. Use this Amp Model to get a tight and punchy, high gain Metal sound.

Insane

Our goal with Insane was to provide you with as much input gain distortion as possible short of complete meltdown. You get an obscene helping of distortion, while still retaining tonal definition and character. As a result, you get way more bottom end and cabinet character than other small amps. Crank up the Drive control and prepare to dominate!

All product names referred to in this manual are trademarks of their respective owners, which are in no way associated or affiliated with Line 6. These trademarks of other manufacturers are used solely to identify the products of those manufacturers whose tones and sounds were studied during Line 6's sound model development.

Footwork (Spider II 30 only)

Two Line 6 foot controllers can be used with the Spider II 30 combo: the FBV4 for channel switching and delay time tap, or the FBV2 for channel scroll. Note that the FBV, FBV Shortboard, Floor Board and FB4 foot controllers will not work with Spider II 30.

FBV foot controllers come with a RJ-45 cable. Connect it between the front panel of the Spider II and the side of the FBV. If you ever need a replacement cable, look for a Category 5 (or higher), "10 Base-T" or "RJ-45" cable with male connectors on both ends. These can be found at almost any computer supply retailer.

FBV2

The FBV2 functions as a two button channel scroll foot switch. Step on its switches to scroll through the four channels (Clean, Crunch, Metal, and Insane) of your Spider II 30.

FBV4

Select from your Spider II's 4 channels. With this pedal, you can also use the foot switch for the active channel to change your Tap Delay Time setting. Just tap the channel button two or more times to the drummer's beat and presto—you're locked in!

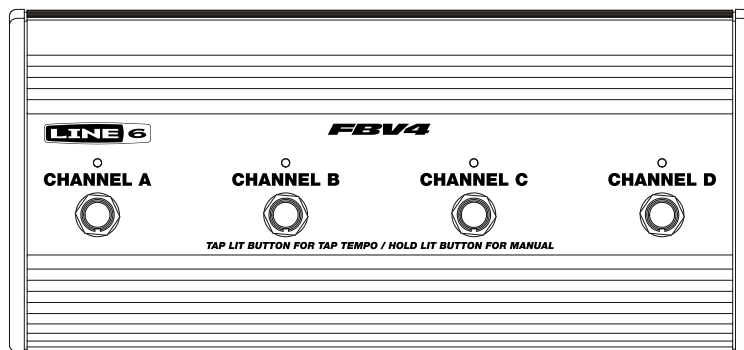
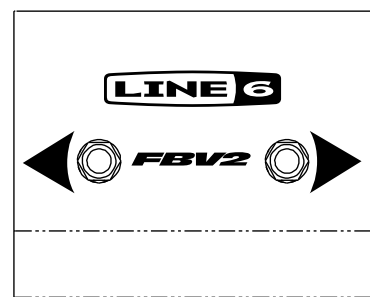

Tap Button Extra Functions

The Tap Delay Time button, in addition to setting the time of your echo effects, also lets you access a Distortion Boost and a built-in Noise Gate.

Distortion Boost

Press and hold the Tap Delay Time button as you turn the Drive knob up past twelve o'clock. As you do this, Spider II's CLEAN Channel light comes on to indicate that the Distortion Boost is on. This gives the kind of extra 'dirt' that you'd expect from a Distortion pedal with the distortion control set low and the output control set high. It boosts your guitar signal before it reaches the Amp Model, so that you hit the model harder and get a more distorted sound.

Noise Gate

Press and hold the Tap Delay Time button as you turn the echo/reverb FX knob up past twelve o'clock, and you'll turn on a built-in Noise Gate to help cut down on hiss and noise. As you do this, the INSANE Channel light comes on to indicate the Gate is on.

Special Hidden Functions

When you select an Amp Model, Spider II automatically sets its tone controls and effects to match that Amp Model. You can disable the auto-FX selection (but not tone control auto-selection) by powering up Spider II with the INSANE Channel button held. The auto-selection will be re-enabled next time you power up.

You can also reset your Spider II's programmable channels to their factory-programmed states by holding down the CLEAN Channel button as you turn on the power. **Warning:** This will erase ALL custom sounds you might have saved. Ask yourself, "Do I really want to do this?" If your answer is yes, then go for it!

WARRANTY INFORMATION

Sending in your registration card allows us to register key information so that we may handle problems faster and inform you of advance information, upgrades and other news. Thanks in advance for filling out your registration card and sending it to us. And good luck in your music!

Line 6, Inc. (hereinafter "Line 6") warrants that your new Line 6 product, when purchased at an authorized Line 6 dealer in the United States of America ("USA") or Canada, shall be free of defects in materials and workmanship for a period of one (1) year from the original date of purchase. Please contact your dealer for information on warranty and service outside of the USA and Canada.

During the warranty period, Line 6 shall, at its sole option, either repair or replace any product that proves to be defective upon inspection by Line 6.

Line 6 reserves the right to update any unit returned for repair and to change or improve the design of the product at any time without notice. Line 6 reserves the right to use reconditioned parts and assemblies as warranty replacements for authorized repairs.

This warranty is extended to the original retail purchaser. This warranty can be transferred to anyone who may subsequently purchase this product provided that such transfer is made within the applicable warranty period and Line 6 is provided with all of the following items: (i) all warranty registration information (as set forth on the registration card) for the new owner, (ii) proof of the transfer within thirty (30) days of the transfer purchase, and (iii) a photocopy of the original sales receipt. Warranty coverage shall be determined by Line 6 in its sole discretion.

This is your sole warranty. Line 6 does not authorize any third party, including any dealer or sales representative, to assume any liability on behalf of Line 6 or to make any warranty for Line 6.

Line 6 may, at its option, require proof of original purchase date in the form of a dated copy of original authorized dealer's invoice or sales receipt. Service and repairs of Line 6 products are to be performed only at the Line 6 factory or a Line 6 authorized service center. Line 6 may require advanced authorization of repairs to authorized service centers. Unauthorized service, repair or modification will void this warranty.

DISCLAIMER AND LIMITATION OF WARRANTY

THE FOREGOING WARRANTY IS THE ONLY WARRANTY GIVEN BY LINE 6 AND IS IN LIEU OF ALL OTHER WARRANTIES. ALL IMPLIED WARRANTIES, INCLUDING WARRANTIES OF MERCHANTABILITY AND FITNESS FOR ANY PARTICULAR PURPOSE, EXCEEDING THE SPECIFIC PROVISIONS OF THIS WARRANTY ARE HEREBY DISCLAIMED AND EXCLUDED FROM THIS WARRANTY. UPON EXPIRATION OF THE APPLICABLE EXPRESS WARRANTY PERIOD (1 YEAR), LINE 6 SHALL HAVE NO FURTHER WARRANTY OBLIGATION OF ANY KIND, EXPRESS OR IMPLIED. LINE 6 SHALL IN NO EVENT BE LIABLE FOR ANY SPECIAL, INCIDENTAL OR CONSEQUENTIAL DAMAGES SUFFERED BY THE PURCHASER OR ANY THIRD PARTY, INCLUDING WITHOUT LIMITATION, DAMAGES FOR LOSS OF PROFITS OR BUSINESS, OR DAMAGES RESULTING FROM USE OR PERFORMANCE OF THE PRODUCT, WHETHER IN CONTRACT OR IN TORT. LINE 6 SHALL NOT BE LIABLE FOR ANY EXPENSES, CLAIMS, OR SUITS ARISING OUT OF OR RELATING TO ANY OF THE FOREGOING. Some states do not allow the exclusion or limitation of implied warranties so some of the above limitations and exclusions may not apply to you. This warranty gives you specific legal rights, and you may also have other rights, which vary from state to state. This warranty only applies to products sold and used in the USA and Canada. Line 6 shall not be liable for damages or loss resulting from the negligent or intentional acts of the shipper or its contracted affiliates. You should contact the shipper for proper claims procedures in the event of damage or loss resulting from shipment.

Pilot's Log

Get tone settings for a collection of great guitar songs from our web site, www.line6.com. Make a note of your favorite settings here by marking which channel is selected, the positions of the knobs, and the Tap Delay Time.

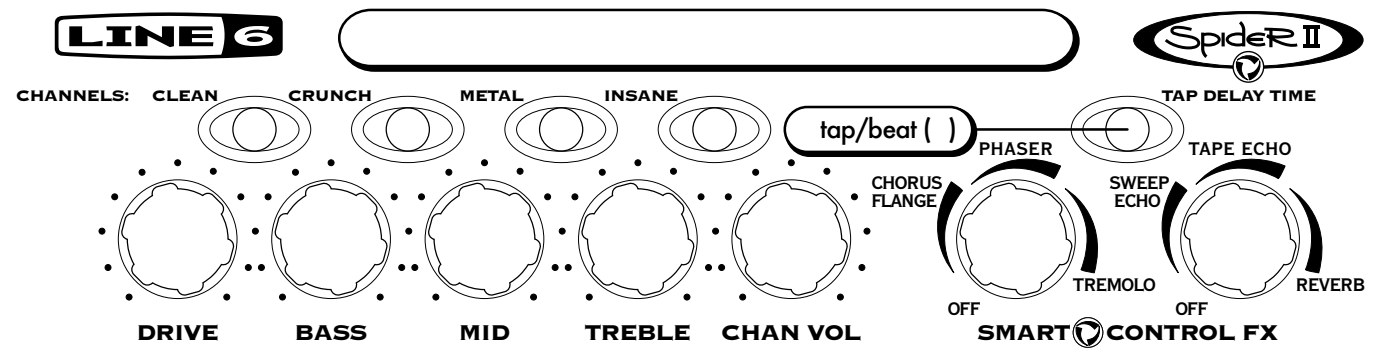
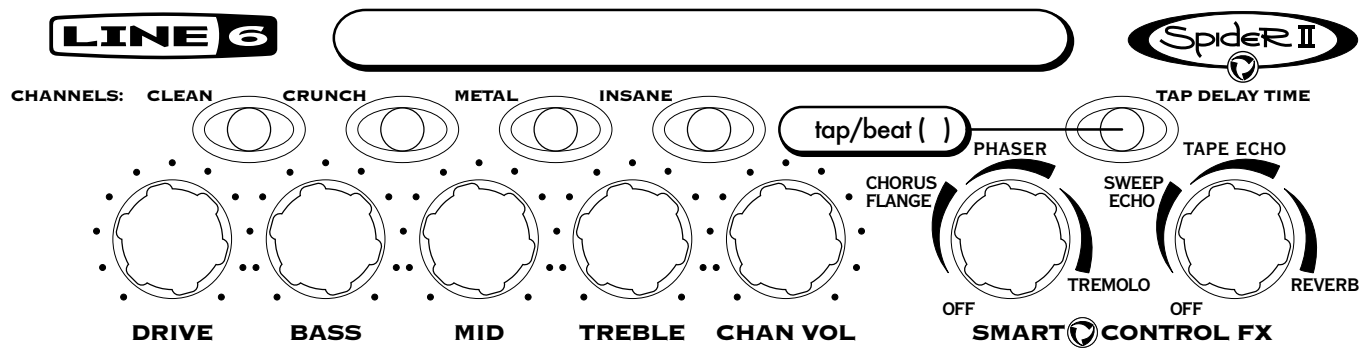
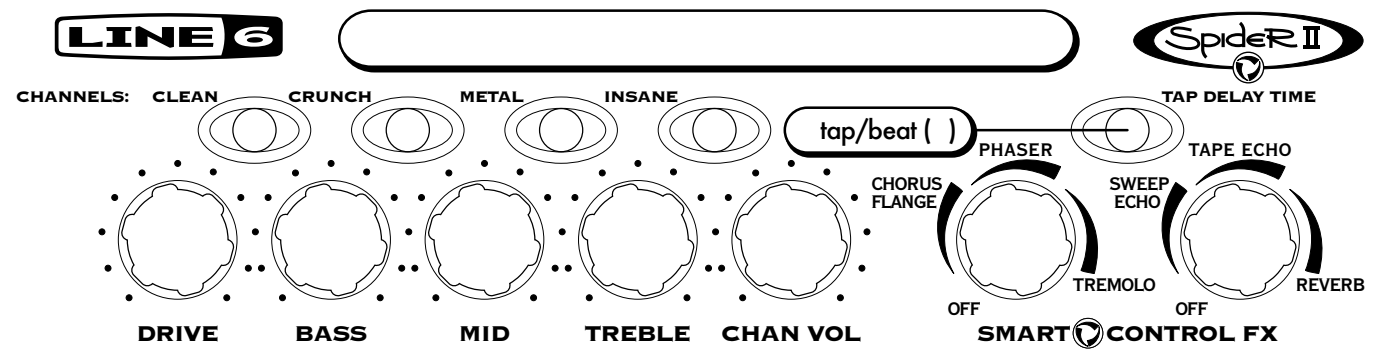
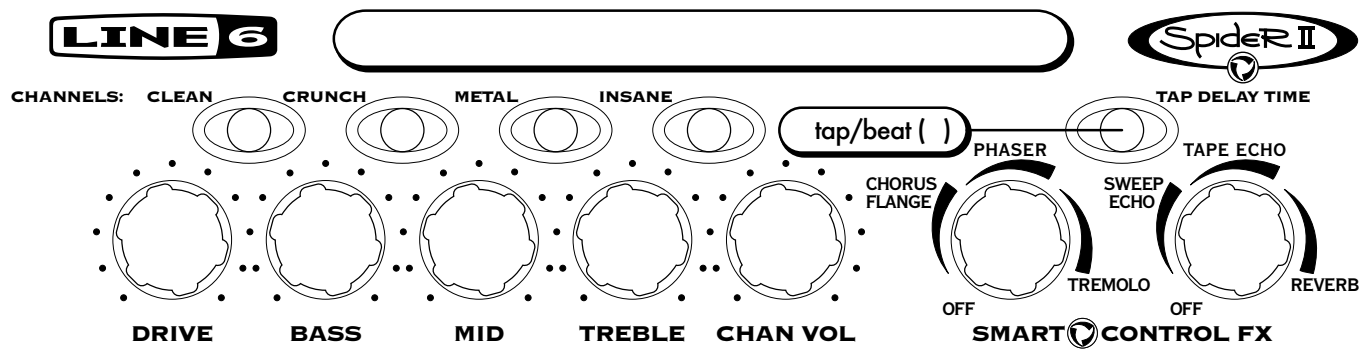
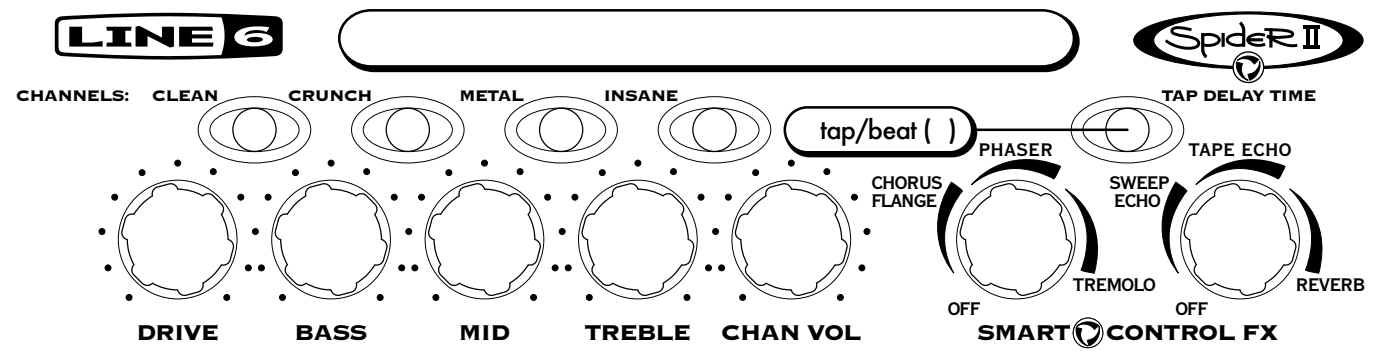
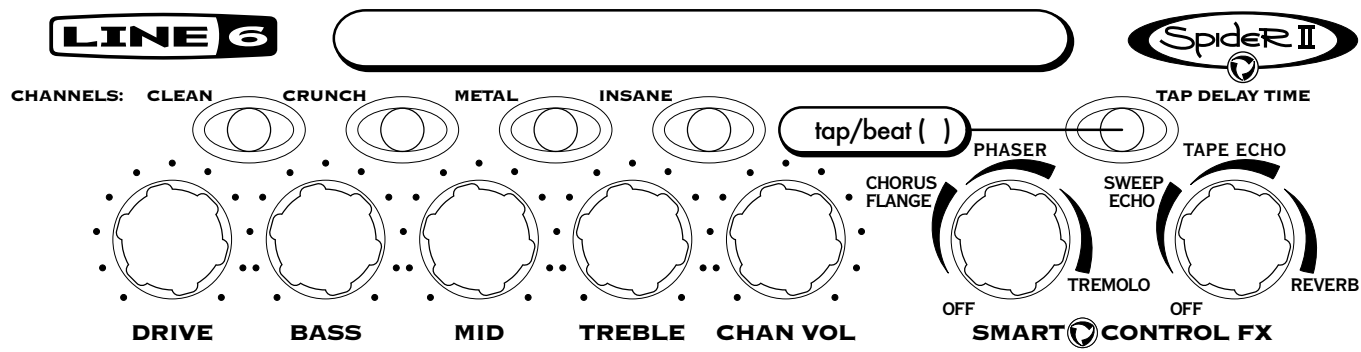
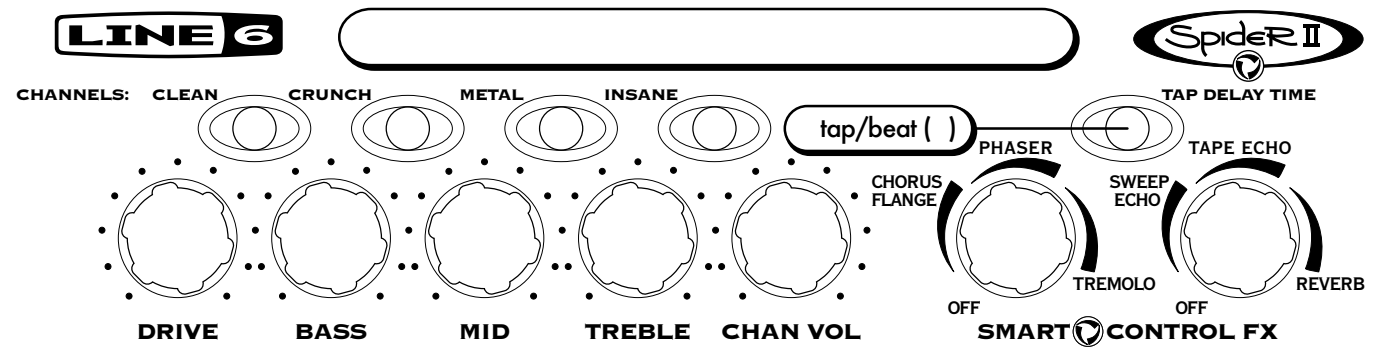
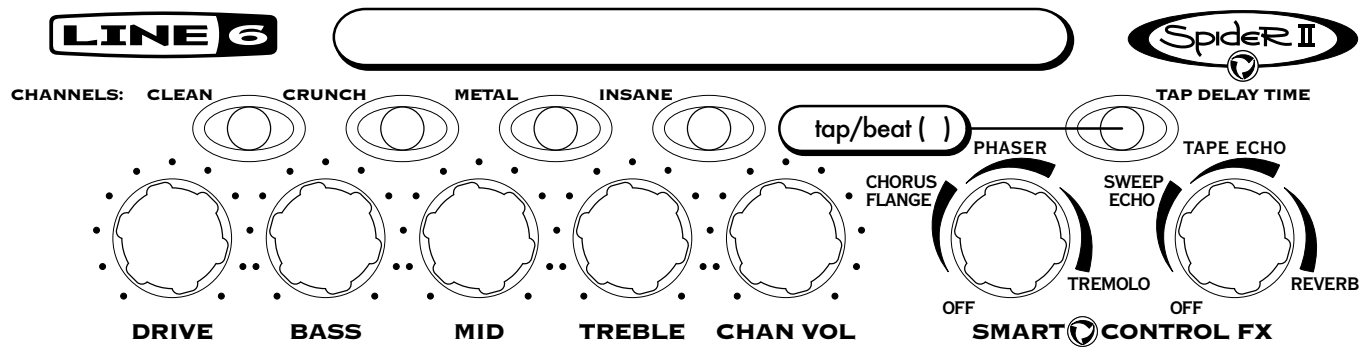
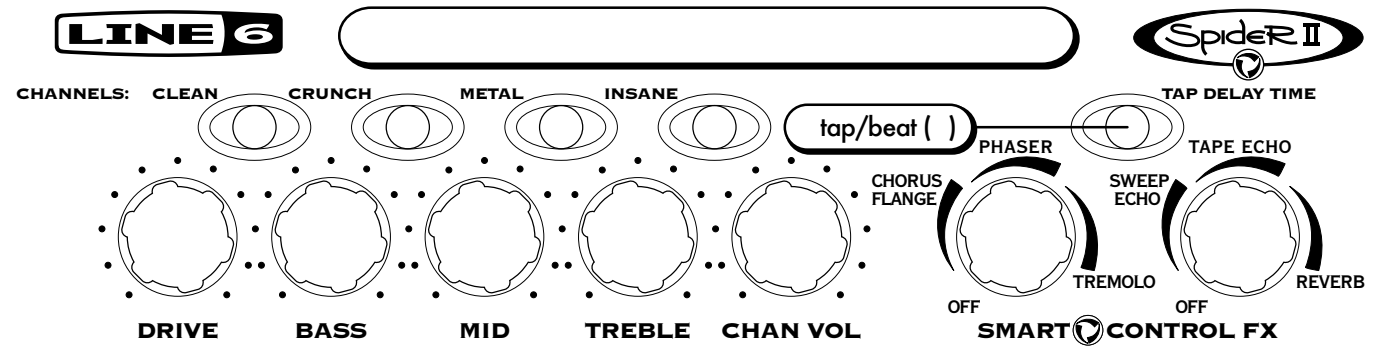
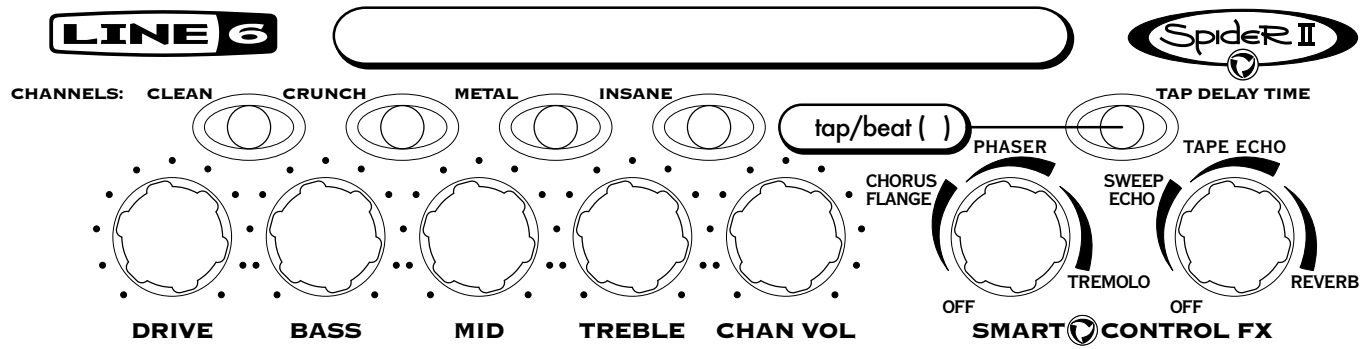
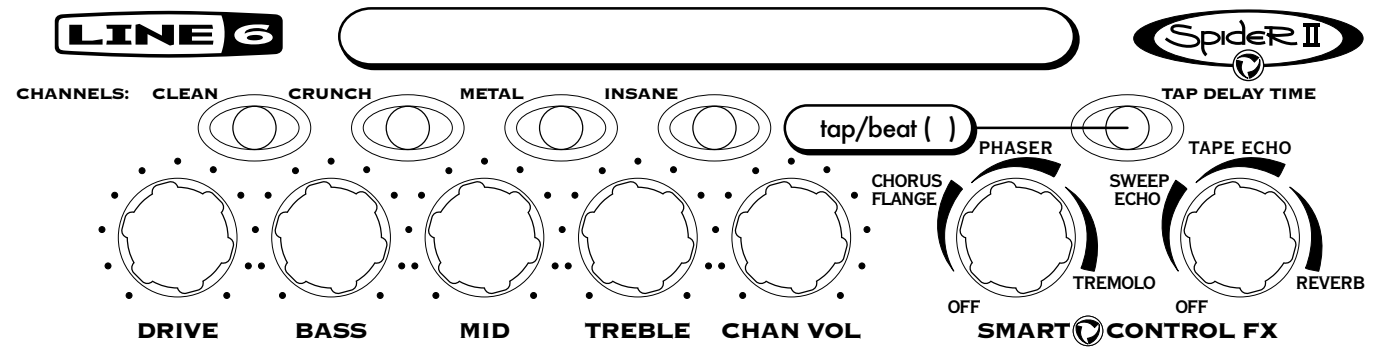
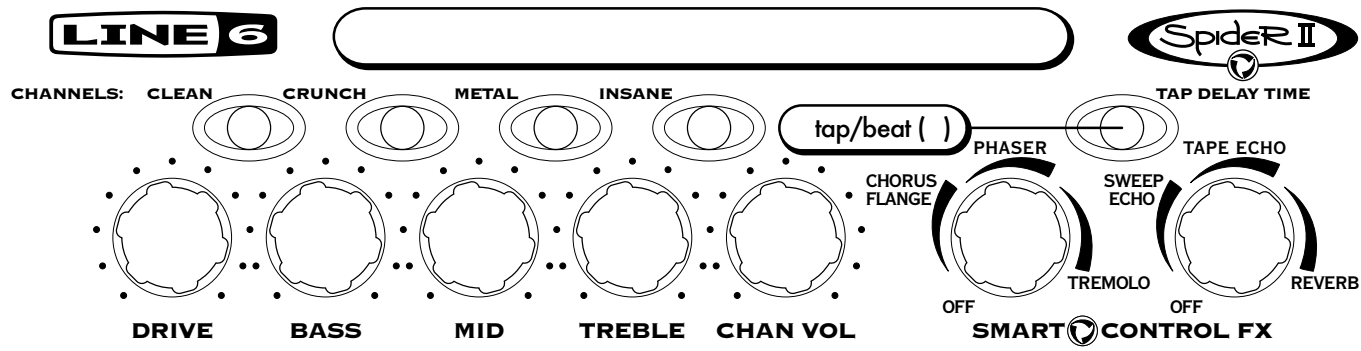
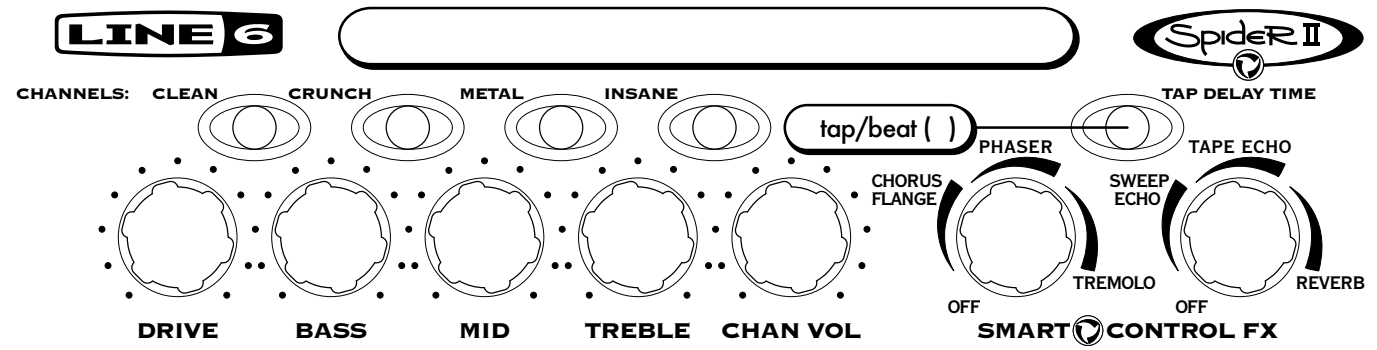
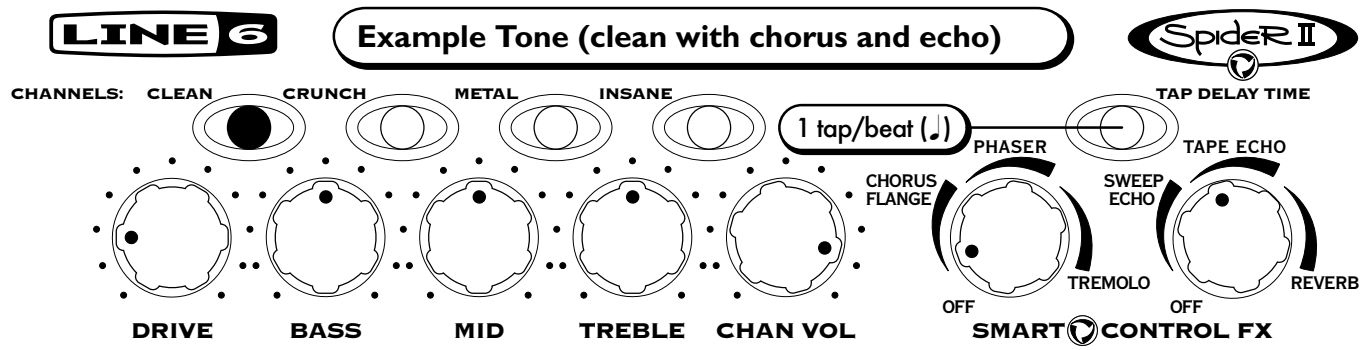

Line 6, Spider II, FBV, FBV Shortboard, FBV4, FBV2, Floor Board, FB4 and Vetta are trademarks of Line 6, Inc. All other product names, trademarks, and artists' names are the property of their respective owners, which are in no way associated or affiliated with Line 6. Product names, images, song names and artists' names are used solely to identify the products whose tones and sounds were studied during Line 6's sound model development for this product. The use of these products, trademarks, images, and artists' names does not imply any cooperation or endorsement.

CAUTION: This equipment has been tested and found to comply with the limits for a Class B digital device pursuant to Part 15 of FCC Rules. Operation is subject to the following two conditions: (1) This device may not cause harmful interference, and (2) this device must accept any interference received, including interference that may cause undesired operation.

WARNING: To reduce the risk of fire or electric shock, do not expose this appliance to rain or moisture.



The exclamation point within a triangle means, "Caution!" Please read the information next to all caution signs.

CAUTION: To reduce the risk of fire or electric shock, do not remove screws. No user-serviceable parts inside. Refer servicing to qualified service personnel.



The lightning symbol within a triangle means, "Electrical caution!" It indicates the presence of information about operating voltage and potential risks of electrical shock.



This symbol within a triangle means, "Caution! Hot surface!" It is shown in areas that may become too hot to touch when the device is in operation.



You should read these Important Safety Instructions. Keep these instructions in a safe place.



Before using your Spider II, carefully read the applicable items of these operating instructions and the safety suggestions.

- Obey all warnings on the amp and in the Spider II Manual.
- Connect only to AC power outlets rated 100-120V or 200-240V 47-63Hz (depending on voltage range of the unit; refer to back panel).
- Do not perform service operations beyond those described in the Spider II Manual. Service is required when the apparatus has been damaged in any way, such as:
 - power-supply cord or plug is damaged
 - liquid has been spilled or objects have fallen into the apparatus
 - the unit has been exposed to rain or moisture
 - the unit does not operate normally or changes in performance in a significant way
 - the unit is dropped or the enclosure is damaged.
- The bottom of the metal chassis can get hot during operation. Do not touch during operation or shortly after.
- Do not place near heat sources, such as radiators, heat registers, or appliances which produce heat. Keep the rear of the unit at least three inches from walls or other items that might block heat radiation.
- Do not block any of the ventilation openings or use in an enclosed space.
- Guard against objects or liquids entering the enclosure. Do not use or place unit near water.
- Do not step on power cords. Do not place items on top of power cords so that they are pinched or leaned on. Pay particular attention to the cord at the plug end and the point where it connects to the amp.
- Unplug the amp when not in use for extended periods of time. Unplug the amp during lightning storms.
- Clean only with a damp cloth.
- Do not defeat the safety purpose of the grounding type plug. A grounding type plug has two blades and a third grounding prong. The third prong is provided for your safety. When the provided plug does not fit into your outlet, consult an electrician for replacement of the obsolete outlet.
- Only use attachments/accessories specified by the manufacturer.
- Prolonged listening at high volume levels may cause irreparable hearing loss and/or damage. Always be sure to practice "safe listening."