

TEST CONDITIONS:	
INSTRUMENT CHANNEL	
GAIN, REV/EFF @ '10'	
LOW, MID, HIGH @ '5'	
FREQ. CUT, DEPTH, RATE @ '0'	
ACTIVE/PIEZO- ON ACTIVE	
SHAPE SWITCH - OUT	
CHORUS SWITCH - IN	
VOCAL/AUX. CHANNEL	
GAIN, REV/EFF @ '10'	
LOW, HIGH @ '5'	
MASTER LEVEL @ '10'	
REV. RETURN @ '10'	
1K Hz SINE WAVE	

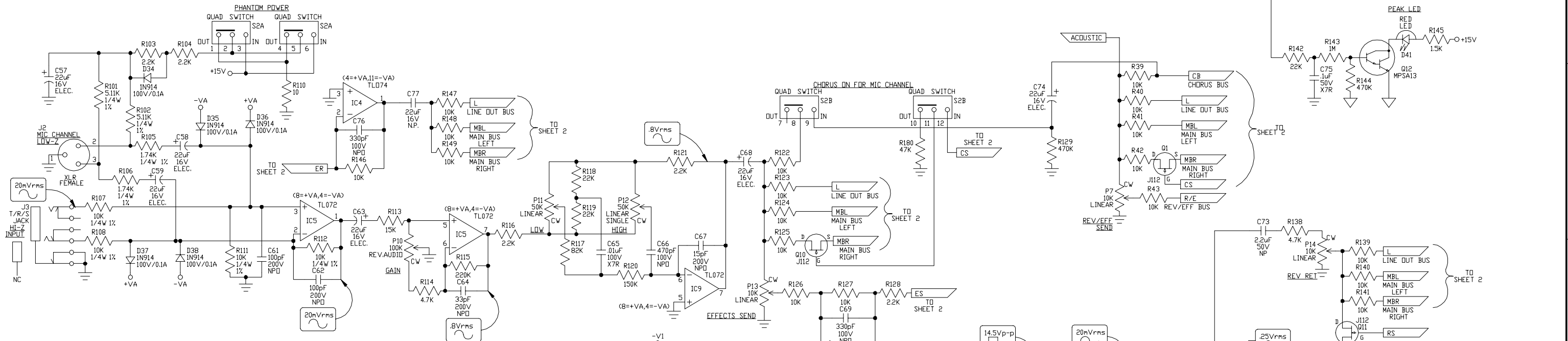
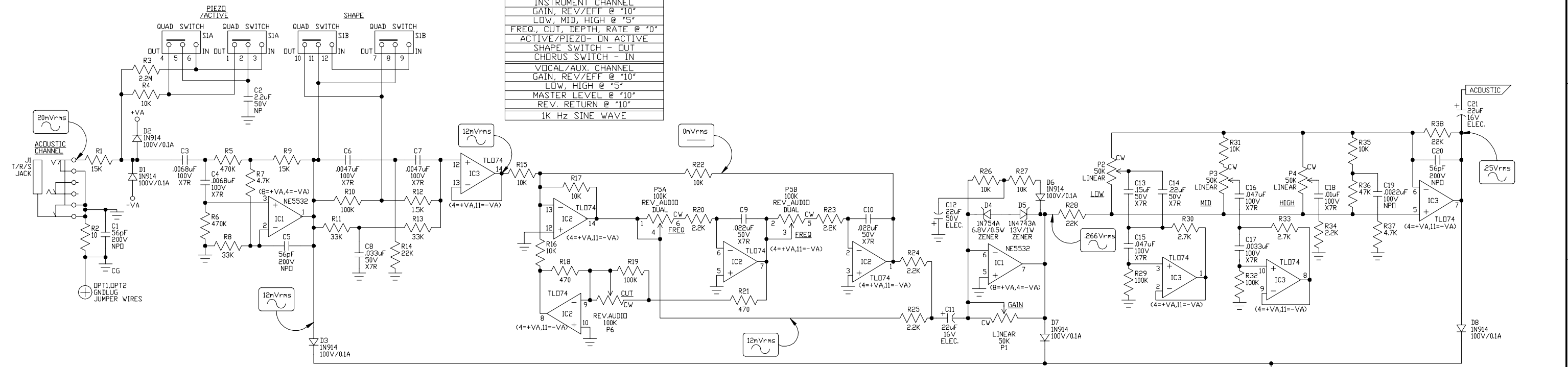

- NOTES**
- CAUTION: SHOCK HAZARD!! THIS UNIT CONTAINS HAZARDOUS VOLTAGE. DISCONNECT POWER AND BE SURE POWER SUPPLY IS DISCHARGED BEFORE TOUCHING INTERNAL PARTS.
  - UNLESS NOTED, RESISTOR VALUES IN OHMS, 1/4W-5% TOL. CAPACITOR VALUES IN MICROFARADS, 50V-10% TOL.
  - VOLTAGES ARE MEASURED WITH 1 MEGOHM OSCILLOSCOPE AND 10 MEGOHM DIGITAL VOLTMETER.
  - CHASSIS GROUND  $\perp$  SIGNAL GROUND  $\nabla$  CIRCUIT GROUND  $\oplus$

**CAUTION:**  
THIS SCHEMATIC IS PROVIDED FOR USE BY QUALIFIED PERSONNEL. TO AVOID RISK OF ELECTRIC SHOCK, REFER SERVICING TO QUALIFIED SERVICE PERSONNEL. DO NOT PERFORM ANY SERVICING BEYOND THAT EXPLAINED IN THE OPERATING INSTRUCTIONS.

ASSY P/N 07-260-01  
REPLACES DWG # 07S244-01

1	12-30-99	ADDED -04	N00168	RLB	
0	10/5/99	CONTROL ISSUE		REM	
A	6/12/99	PRELIM ISSUE		REM	
REV:	DATE:	DESCRIPTION	ECR/ECN NO.:	CHNG'D BY:	APPR'D BY:
THE INFORMATION CONTAINED ON THIS DRAWING IS PROPRIETARY TO ST. LOUIS MUSIC, INC.					
SIGNATURES:		DATE:	11890 Borman Dr. St. Louis, Missouri 63146		
DRAWN:	REM	6/12/99	FIRST USED ON:		
CHK'D:		6/12/99	CA60a/CA60Da		
RLS'D:			DRAWING TITLE:		
DRAWING SIZE:		D	SCHEMO - ACOUSTIC AMP		
DRAWING TYPE:		SCHEMO	DRAWING NO.:		
CLASS CODE:			07S260-XX		
SCALE:		NONE	SHEET: 1 OF 6		

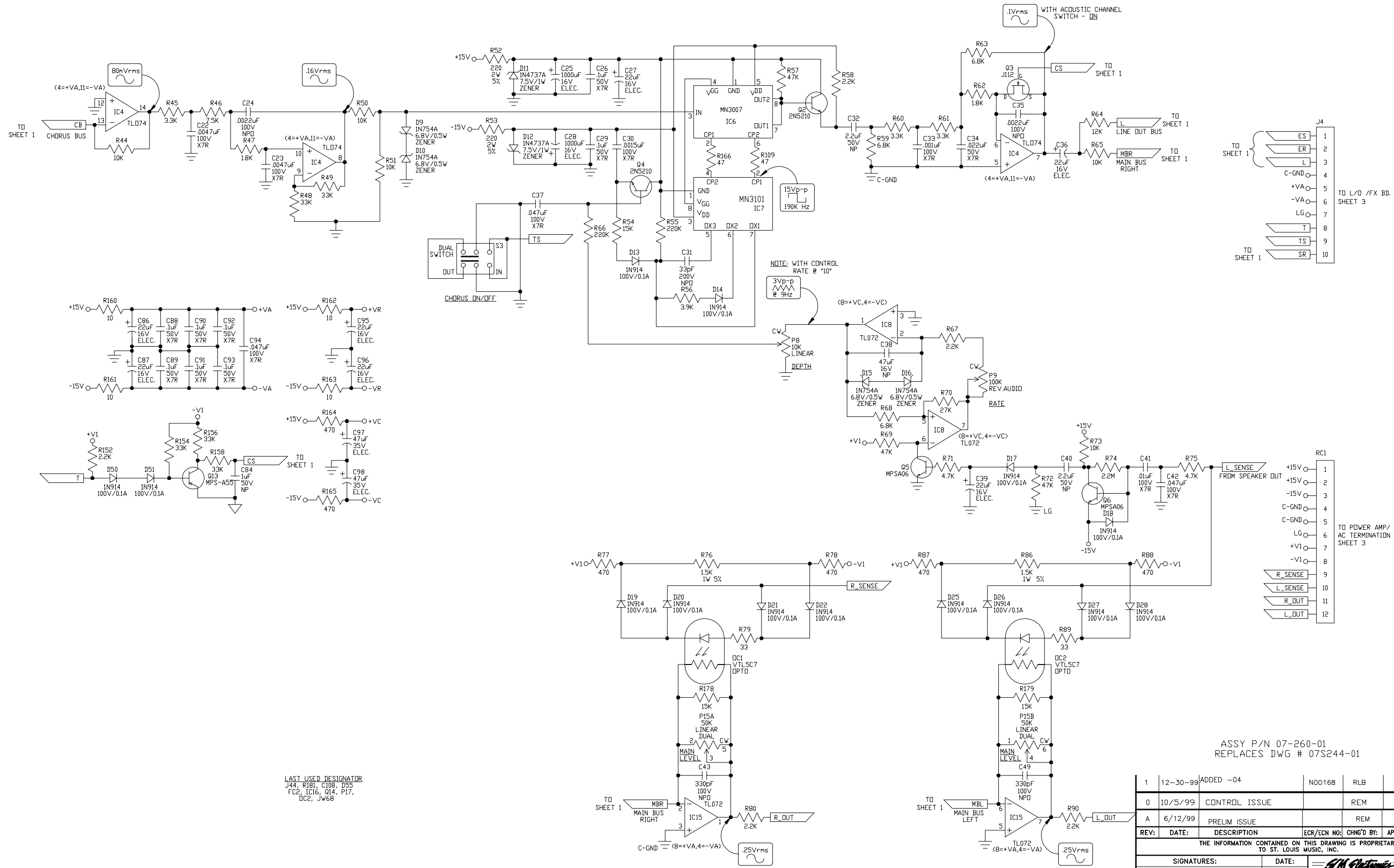

LAST USED DESIGNATOR  
 J44, R181, C108, D55  
 FC2, IC16, Q14, P17,  
 DC2, JW68

ASSY P/N 07-260-01  
 REPLACES DWG # 07S244-01

1	12-30-99	ADDED -04	N00168	RLB	
0	10/5/99	CONTROL ISSUE		REM	
A	6/12/99	PRELIM ISSUE		REM	
REV:	DATE:	DESCRIPTION	ECR/ECN NO:	CHNG'D BY:	APPR'D BY:
THE INFORMATION CONTAINED ON THIS DRAWING IS PROPRIETARY TO ST. LOUIS MUSIC, INC.					
SIGNATURES:		DATE:			
DRAWN:	REM	6/12/99			
CHK'D:		6/12/99			
RLS'D:		FIRST USED ON: CA60a/CA60Dα			
TOLERANCES:	DRAWING SIZE: D	DRAWING TITLE: SCHEMO - ACOUSTIC AMP			
	DRAWING TYPE: SCHEMO	DRAWING NO.:			
	CLASS CODE:	DRAWING NO.: 07S260-XX			
	SCALE: NONE	SHEET: 2 OF 6			

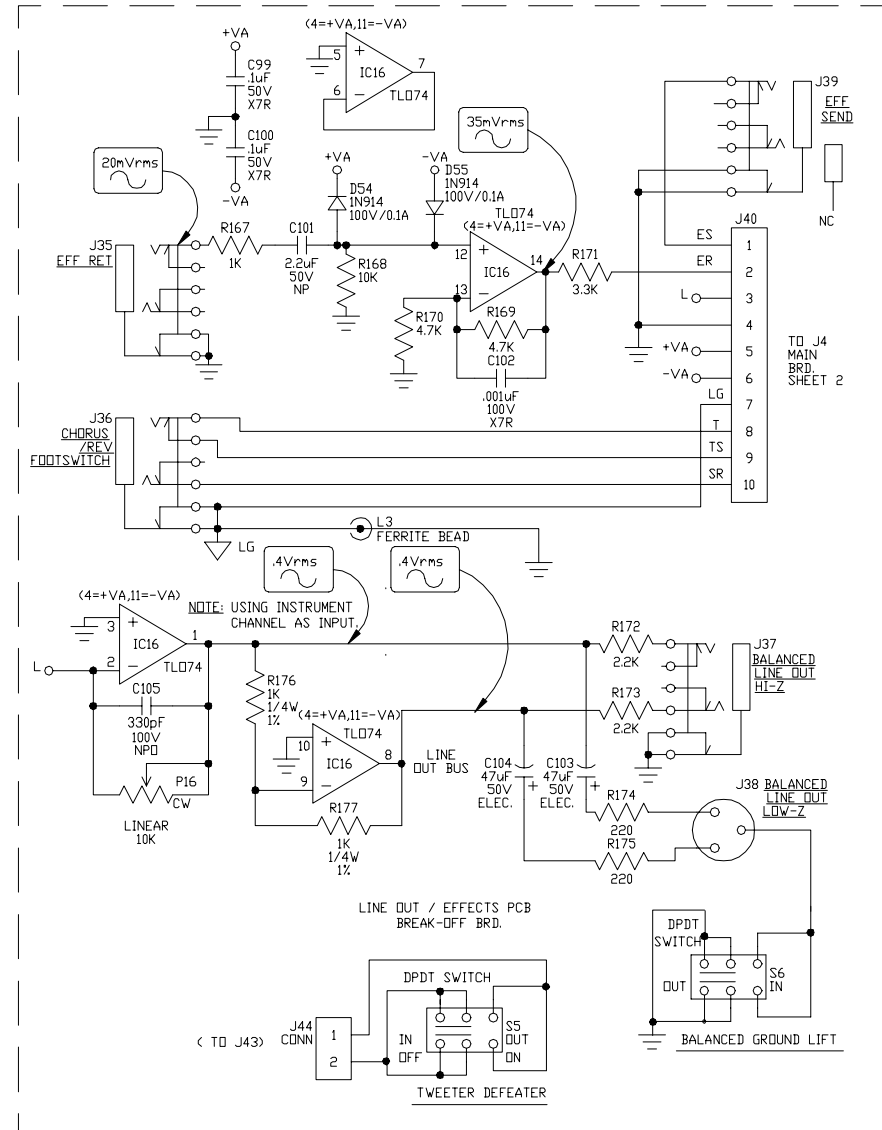
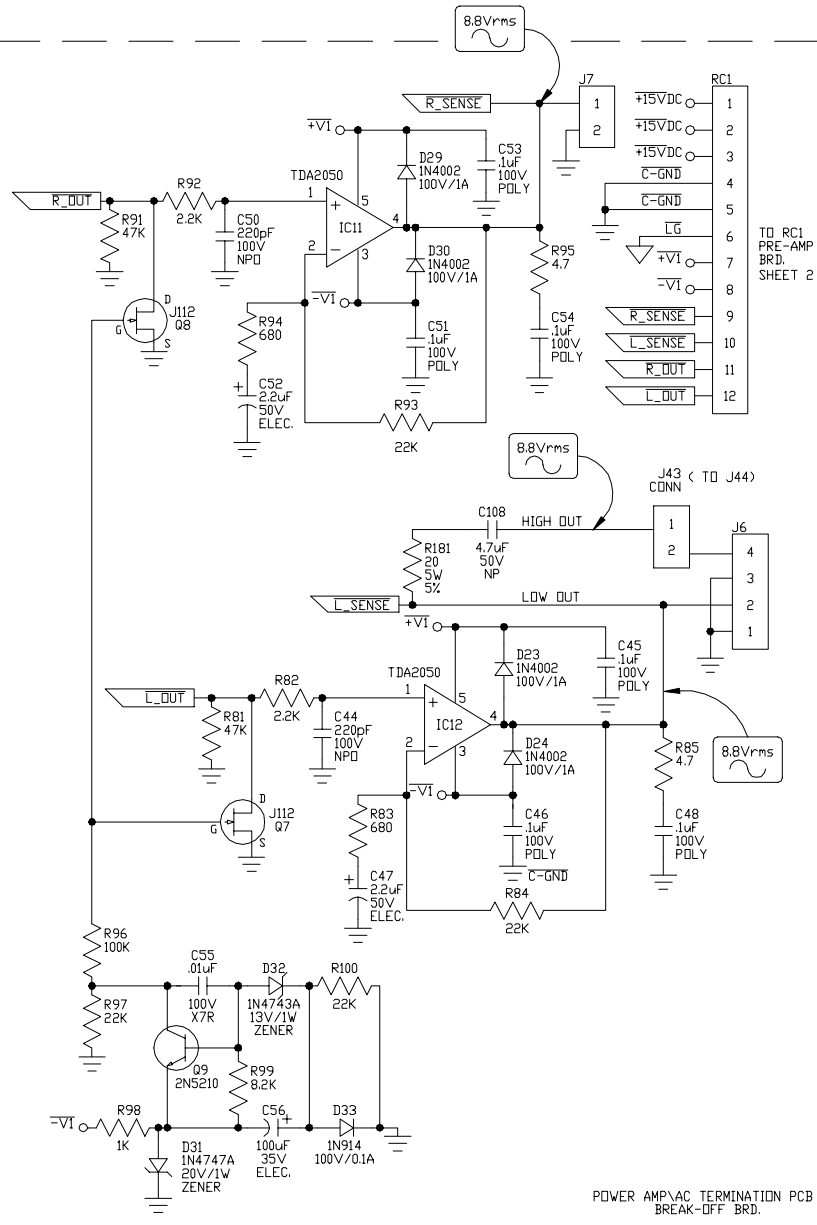
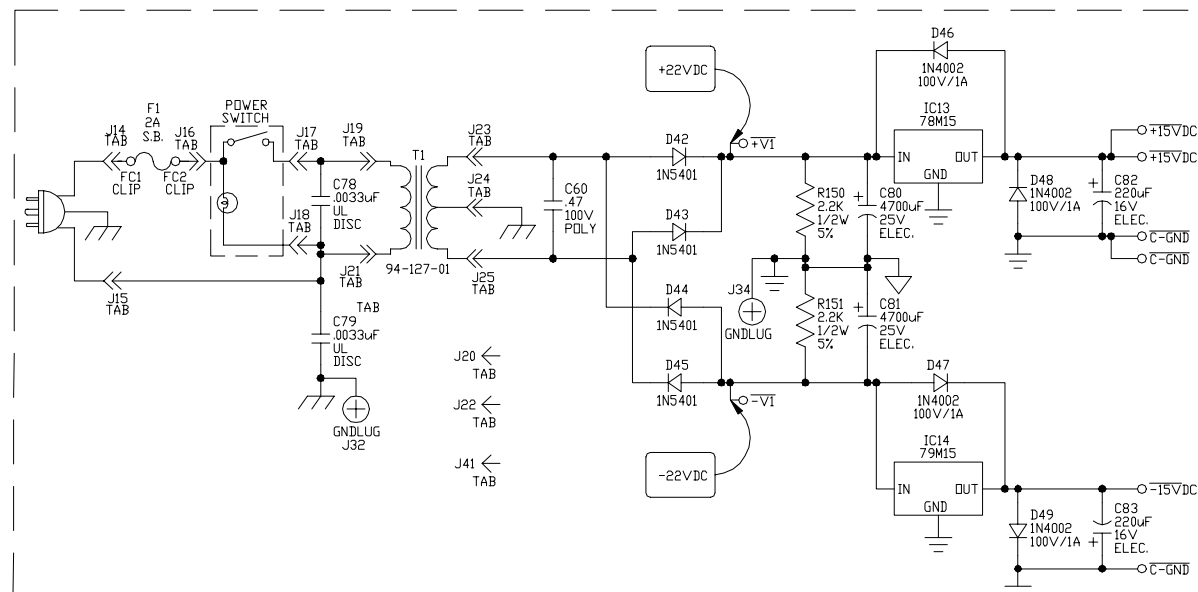

**EXPORT WIRING**

94-127-40  
TRANSFORMER

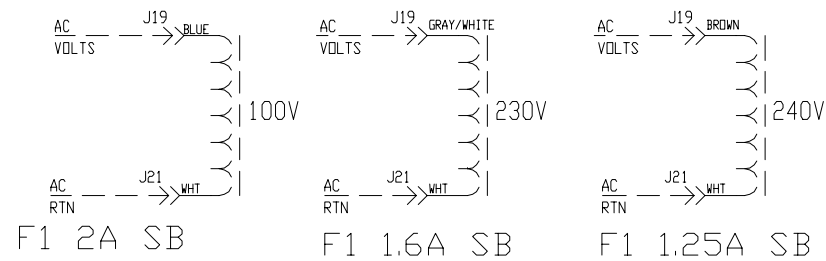

USE J20, J22, OR J41 FOR UNUSED PRIMARY LEADS.

ASSY P/N 07-260-01  
REPLACES DWG # 07S244-01

1	12-30-99	ADDED -04	N00168	RLB		
0	10/5/99	CONTROL ISSUE		REM		
A	6/12/99	PRELIM ISSUE		REM		
REV:	DATE:	DESCRIPTION	ECR/ECN NO:	CHNG'D BY:	APPR'D BY:	DATE:
THE INFORMATION CONTAINED ON THIS DRAWING IS PROPRIETARY TO ST. LOUIS MUSIC, INC.						
SIGNATURES:		DATE:		11890 Borman Dr. St. Louis, Missouri 63146		
DRAWN:	REM	6/12/99		FIRST USED ON:		
CHK'D:		6/12/99		CA60a/CA60Da		
RLS'D:				DRAWING TITLE:		
DRAWING SIZE: D		DRAWING TYPE: SCHEMO		SCHEMO - ACOUSTIC AMP		
DRAWING TYPE: SCHEMO		CLASS CODE:		DRAWING NO.:		
SCALE: NONE		SHEET: 3 OF 6		07S260-XX		

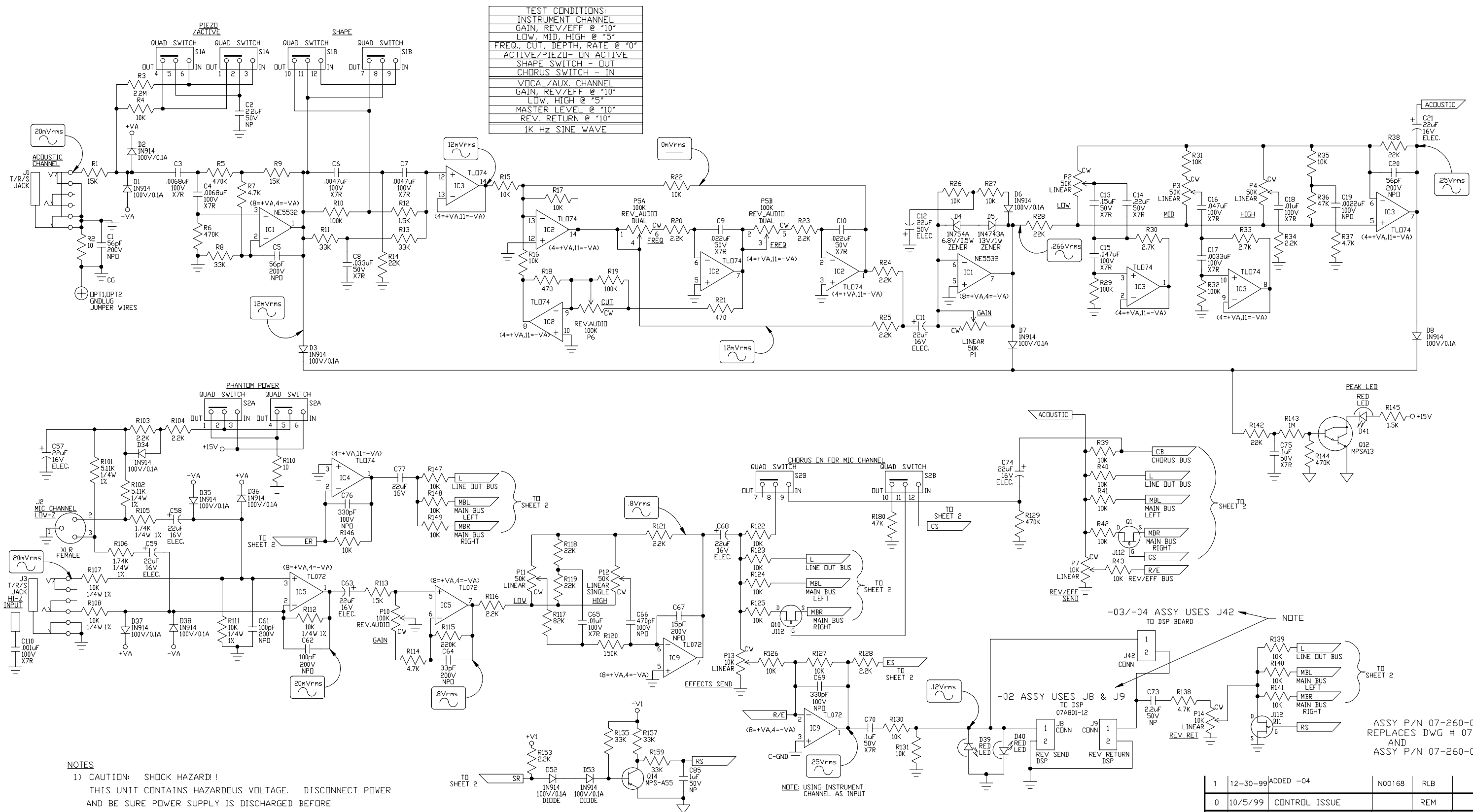

TEST CONDITIONS:  
 INSTRUMENT CHANNEL  
 GAIN, REV/EFF @ "10"  
 LOW, MID, HIGH @ "5"  
 FREQ. CUT, DEPTH, RATE @ "0"  
 ACTIVE/PIEZO - ON ACTIVE  
 SHAPE/PIEZO - OUT  
 CHORUS SWITCH - IN  
 VDCAL/AUX. CHANNEL  
 GAIN, REV/EFF @ "10"  
 LOW, HIGH @ "5"  
 MASTER LEVEL @ "10"  
 REV. RETURN @ "10"  
 1K HZ SINE WAVE

- NOTES
- 1) CAUTION: SHOCK HAZARD!! THIS UNIT CONTAINS HAZARDOUS VOLTAGE. DISCONNECT POWER AND BE SURE POWER SUPPLY IS DISCHARGED BEFORE TOUCHING INTERNAL PARTS.
  - 2) UNLESS NOTED, RESISTOR VALUES IN OHMS, 1/4W-5% TOL. CAPACITOR VALUES IN MICROFARADS, 50V-10% TOL.
  - 3) VOLTAGES ARE MEASURED WITH 1 MEGOHM OSCILLOSCOPE AND 10 MEGOHM DIGITAL VOLTMETER.
  - 4) CHASSIS GROUND  $\equiv$  SIGNAL GROUND  $\nabla$  CIRCUIT GROUND  $\nabla$

CAUTION:  
 THIS SCHEMATIC IS PROVIDED FOR USE BY QUALIFIED PERSONNEL. TO AVOID RISK OF ELECTRIC SHOCK, REFER SERVICING TO QUALIFIED SERVICE PERSONNEL. DO NOT PERFORM ANY SERVICING BEYOND THAT EXPLAINED IN THE OPERATING INSTRUCTIONS.

1	12-30-99	ADDED -04	N00168	RLB		
0	10/5/99	CONTROL ISSUE		REM		
A	6/12/99	PRELIM ISSUE		REM		
REV:	DATE:	DESCRIPTION	ECR/ECN NO:	CHNG'D BY:	APPR'D BY:	DATE:
THE INFORMATION CONTAINED ON THIS DRAWING IS PROPRIETARY TO ST. LOUIS MUSIC, INC.						
SIGNATURES:		DATE:		11880 Borman Dr. St. Louis, Missouri 63146		
DRAWN: REM		6/12/99		FIRST USED ON:		
CHK'D:		6/12/99		CA60a/CA60d		
RLS'D:				DRAWING TITLE:		
TOLERANCES:		DRAWING SIZE: D		SCHEMO - ACOUSTIC AMP		
		DRAWING TYPE: SCHEMO		DRAWING NO.:		
		CLASS CODE:		07S260-XX		
		SCALE: NONE		SHEET: 4 OF 6		

ASSY P/N 07-260-02 REPLACES DWG # 07S244-02 AND ASSY P/N 07-260-03/04

NOTE: -03/-04 ASSY USES J42 TO DSP BOARD

NOTE: -02 ASSY USES J8 & J9 TO DSP 07A801-12

NOTE: USING INSTRUMENT CHANNEL AS INPUT

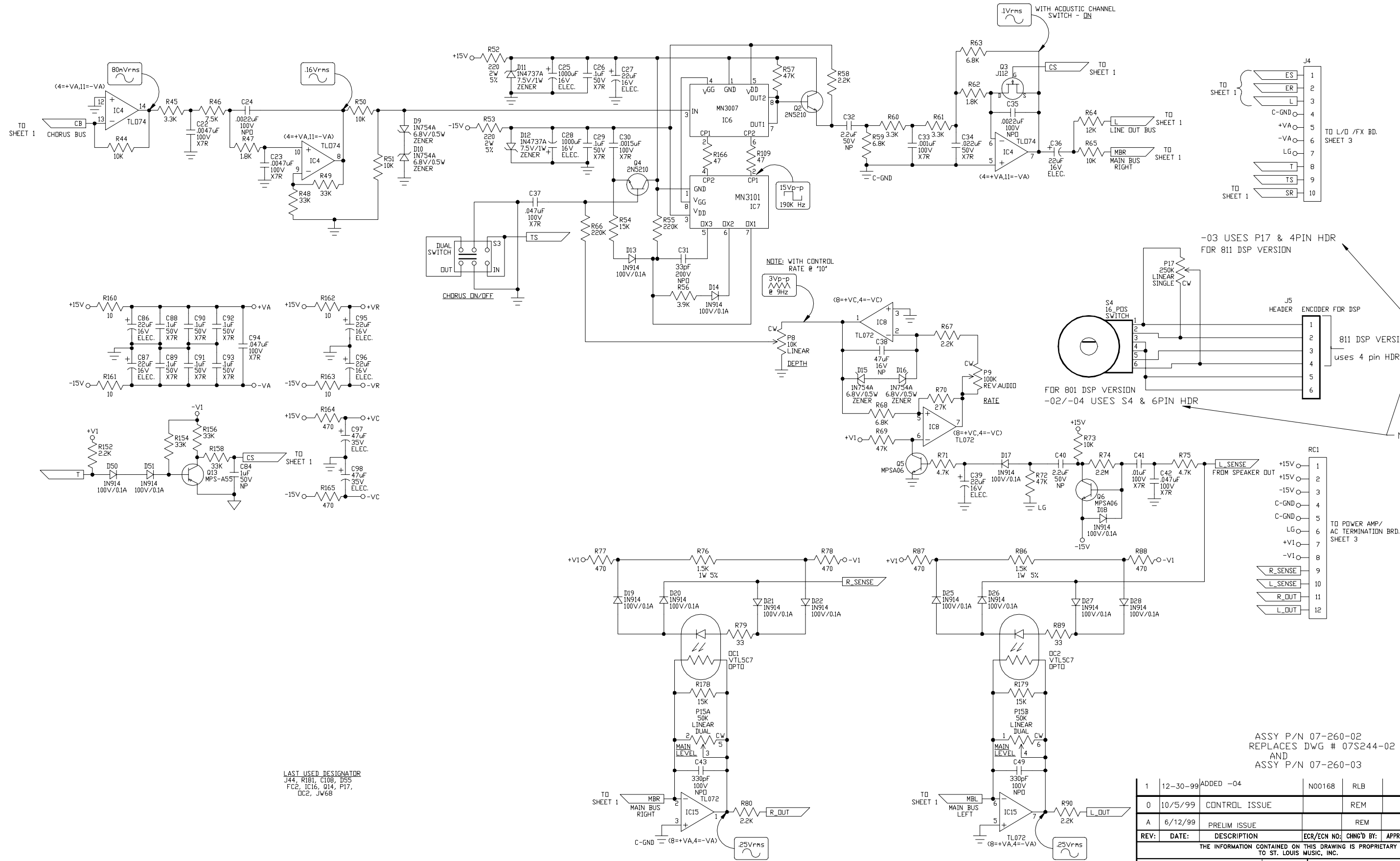

LAST USED DESIGNATOR  
 J44, R181, C108, D55  
 FC2, IC16, Q14, P17,  
 DC2, JW68

ASSY P/N 07-260-02  
 REPLACES DWG # 07S244-02  
 AND  
 ASSY P/N 07-260-03

1	12-30-99	ADDED -04	N00168	RLB		
0	10/5/99	CONTROL ISSUE		REM		
A	6/12/99	PRELIM ISSUE		REM		
REV:	DATE:	DESCRIPTION	ECR/ECN NO:	CHNG'D BY:	APPR'D BY:	DATE:
THE INFORMATION CONTAINED ON THIS DRAWING IS PROPRIETARY TO ST. LOUIS MUSIC, INC.						
SIGNATURES:		DATE:				
DRAWN: REM		6/12/99		11880 Borman Dr. St. Louis, Missouri 63146		
CHK'D:		6/12/99		FIRST USED ON:		
RLS'D:				CA60a/CA60d		
TOLERANCES:		DRAWING SIZE: D		DRAWING TITLE: SCHEMO - ACOUSTIC AMP		
		DRAWING TYPE: SCHEMO		DRAWING NO.:		
		CLASS CODE:		07S260-XX		
		SCALE: NONE		SHEET: 5 OF 6		

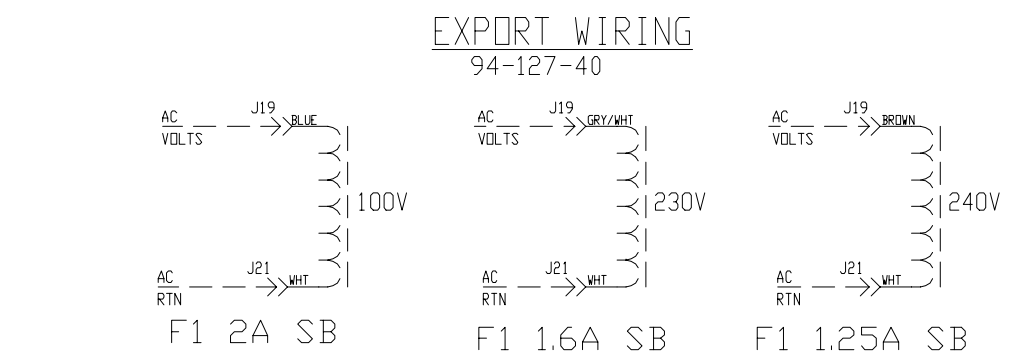
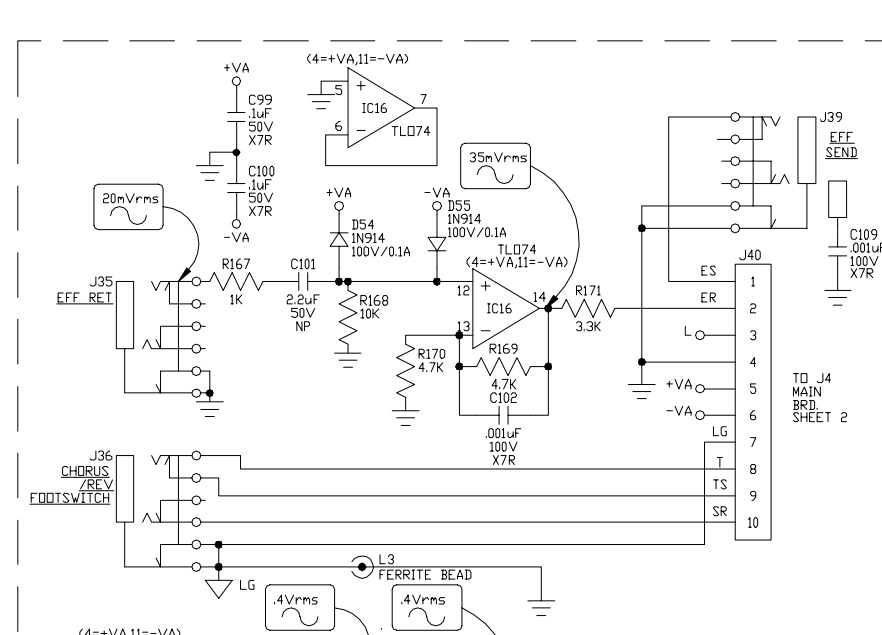
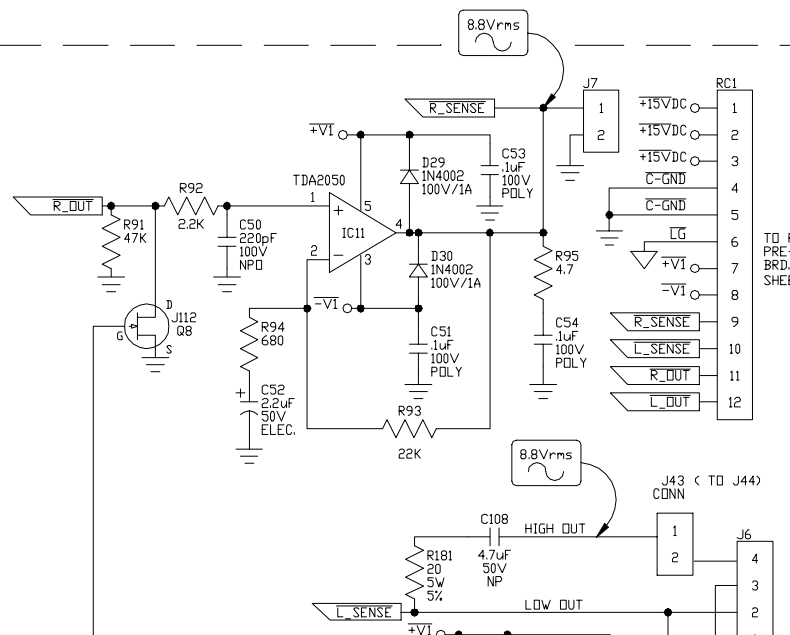
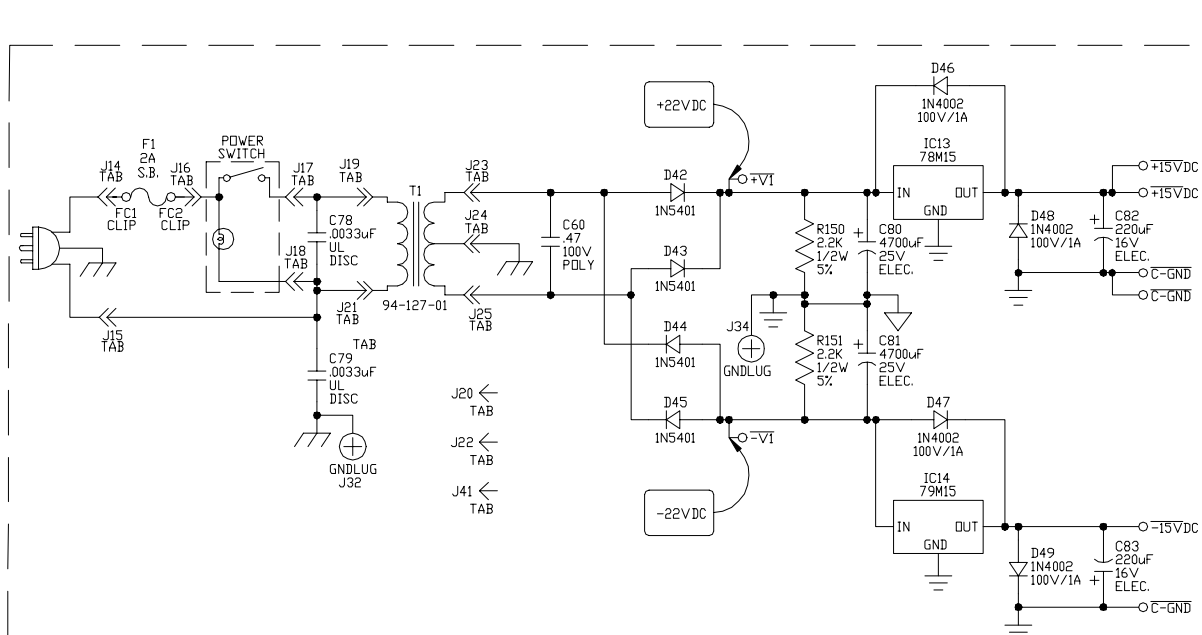

USE J20, J22, OR J41 FOR UNUSED PRI. LEADS.

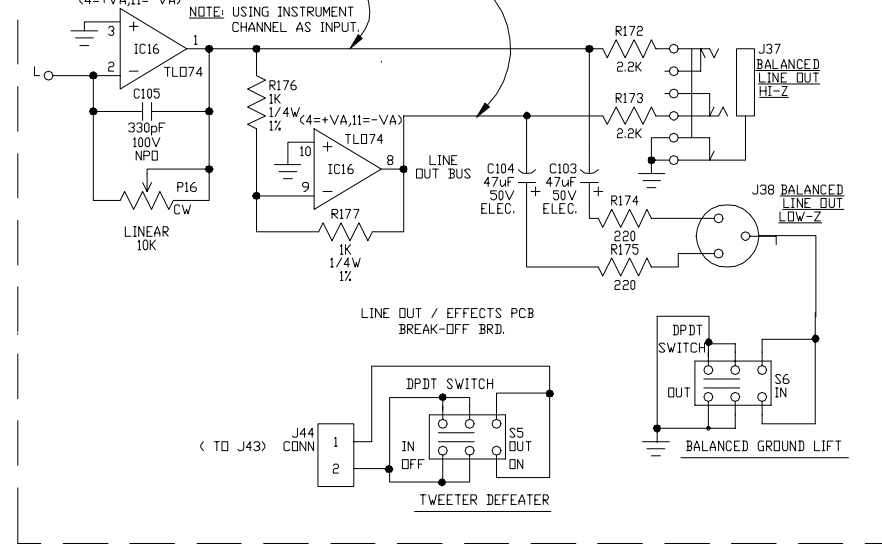
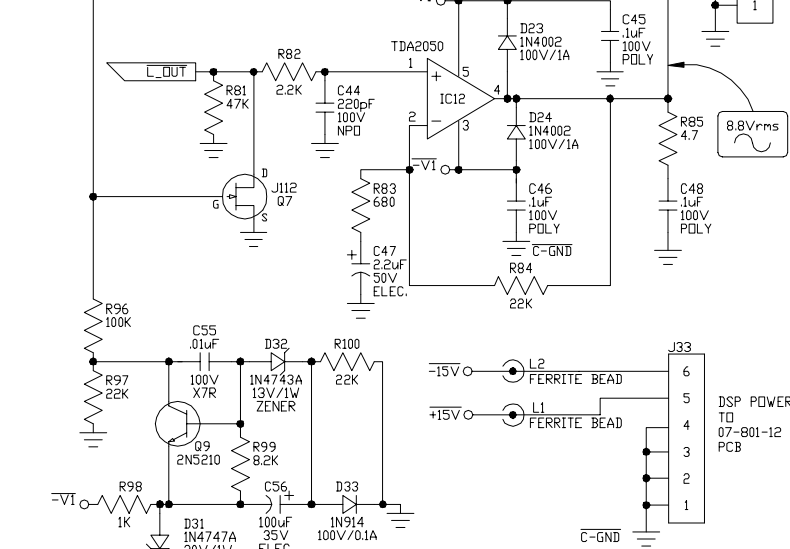

ASSY P/N 07-260-02  
REPLACES DWG # 07S244-02  
AND  
ASSY P/N 07-260-03

1	12-30-99	ADDED	07-260-03	NO0168	RLB		
0	10/5/99	CONTROL ISSUE				REM	
A	6/12/99	PRELIM ISSUE				REM	
REV:	DATE:	DESCRIPTION	ECR/ECN NO:	CHNG'D BY:	APPR'D BY:	DATE:	
THE INFORMATION CONTAINED ON THIS DRAWING IS PROPRIETARY TO ST. LOUIS MUSIC, INC.							
SIGNATURES:		DATE:					
DRAWN: REM		6/12/99		11880 Borman Dr. St. Louis, Missouri 63146			
CHK'D:		6/12/99		FIRST USED ON:			
RLS'D:				CA60a/CA60d			
TOLERANCES:		DRAWING SIZE: D		DRAWING TITLE: SCHEMO - ACOUSTIC AMP			
		DRAWING TYPE: SCHEMO		DRAWING NO.:			
		CLASS CODE:		07S260-XX			
		SCALE: NONE		SHEET: 6 OF 6			