

TRACE ELLIOT

SERVICE MANUAL

DATE : December 29, 1999
Product Code: N/A
Model Number : GP12 200 watt series 6

Issued by:
Trace Elliot Limited
Blackwater Trading Estate
The Causeway
Maldon
Essex
England
CM4 4GG

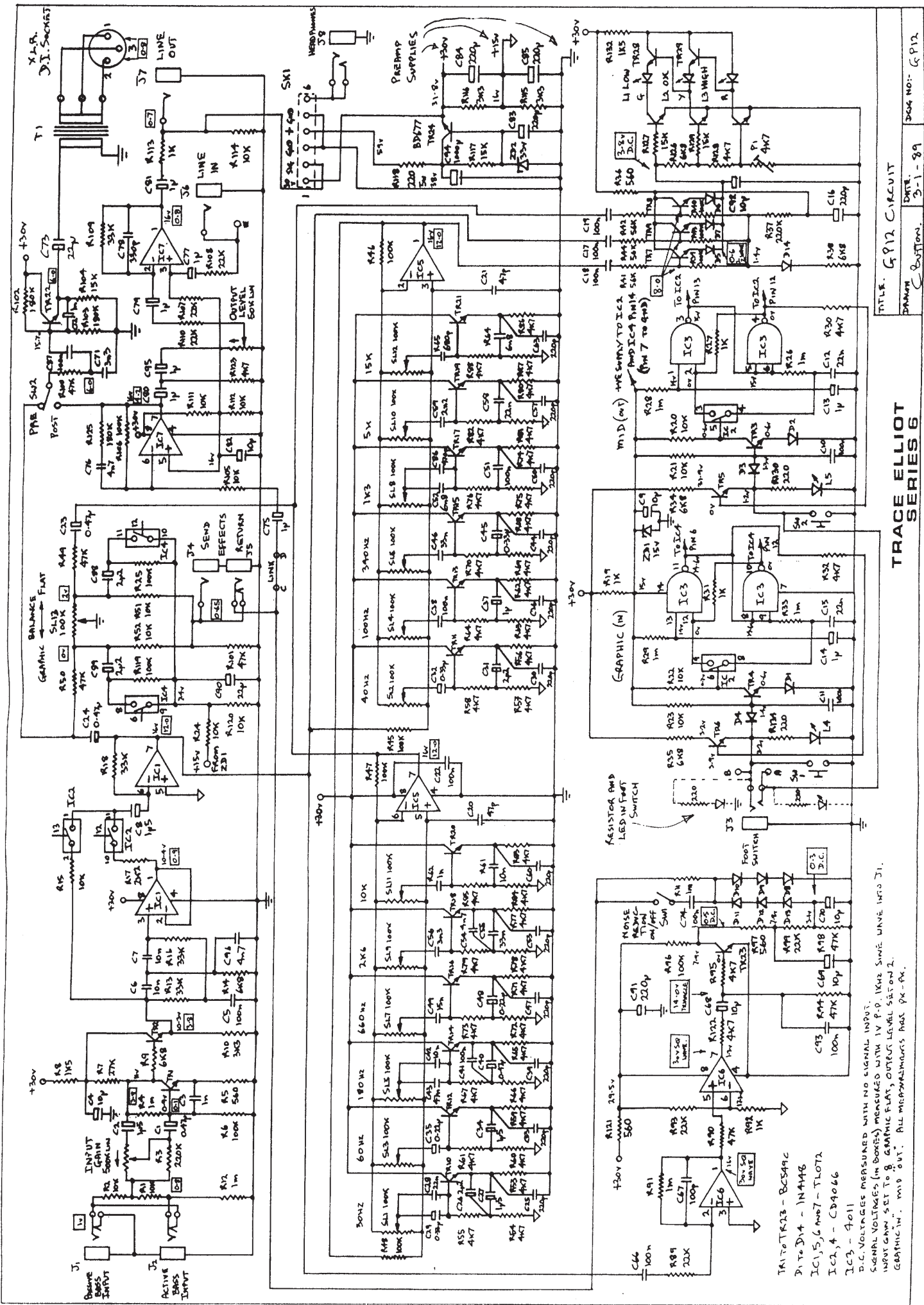

TITLE: G.P.12 CIRCUIT

TRACE ELLIOT SERIES 6

DATE: 5-1-89

DRWING BOTTOM

3046 NO. GP12

IC1, 2, 3 - 4011
 IC2, 4 - CD4066
 IC3, 5, 6 - TLO72
 IC4, 7 - 1N4148
 IC5 - BC549C
 TR1 TO TR4 - 1N4148

D.C. VOLTAGES MEASURED WITH NO SIGNAL INPUT.
 SIGNAL VOLTAGES (IN BOXES) MEASURED WITH 1V P.P. 1KHz SINE WAVE INTO J1.
 INPUT GAIN SET TO 8. GRAPHIC FLAT, OUTPUT LEVEL SET ON 2.
 GRAPHIC IN. MID OUT. ALL MEASUREMENTS MADE PK-PK.

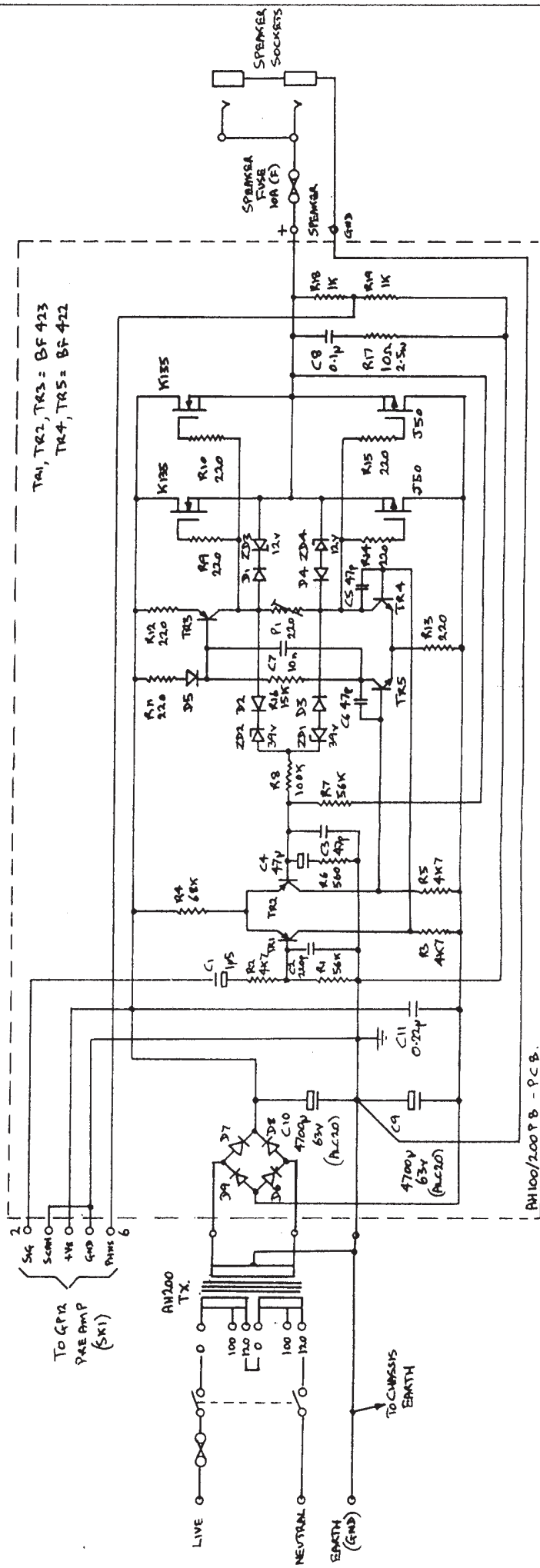

TR1, TR2, TR3 = BF 423
TR4, TR5 = BF 422

TRACE ELLIOT SERIES 6

TYPE	AH200 OUTPUT STAGE
DESIGN	C. BUTTON
DATE	6-2-89
DWG. NO.	AH200



SERVICE INFORMATION

GP12 MAIN BOARD - COMPONENT PARTS LIST

REF	PART NUMBER	VALUE	REF	PART NUMBER	VALUE
R1	1610-RM10K	10K 1/4W MF	R61	1610-RM4K7	4K7 1/4W MF
R2	1610-RM10K	10K 1/4W MF	R62	1610-RM4K7	4K7 1/4W MF
R3	1610-RM220K	220K 1/4W MF	R63	1610-RM4K7	4K7 1/4W MF
R4	1610-RM1M	1M 1/4W MF	R64	1610-RM4K7	4K7 1/4W MF
R5	1610-RM560R	560R 1/4W MF	R65	1610-RM4K7	4K7 1/4W MF
R6	1610-RM100K	100K 1/4W MF	R66	1610-RM4K7	4K7 1/4W MF
R7	1610-RM27K	27K 1/4W MF	R67	1610-RM4K7	4K7 1/4W MF
R8	1610-RM1K5	1K5 1/4W MF	R68	1610-RM4K7	4K7 1/4W MF
R9	1610-RM6K8	6K8 1/4W MF	R69	1610-RM4K7	4K7 1/4W MF
R10	1610-RM3K3	3K3 1/4W MF	R70	1610-RM4K7	4K7 1/4W MF
R11	1610-RM1M	1M 1/4W MF	R71	1610-RM4K7	4K7 1/4W MF
R12	1610-RM1M	1M 1/4W MF	R72	1610-RM4K7	4K7 1/4W MF
R13	1610-RM33K	33K 1/4W MF	R73	1610-RM4K7	4K7 1/4W MF
R14	1610-RM6K8	6K8 1/4W MF	R74	1610-RM4K7	4K7 1/4W MF
R15	1610-RM10K	10K 1/4W MF	R75	1610-RM4K7	4K7 1/4W MF
R16	1610-RM33K	33K 1/4W MF	R76	1610-RM4K7	4K7 1/4W MF
R17	1610-RM2K2	2K2 1/4W MF	R77	1610-RM4K7	4K7 1/4W MF
R18	1610-RM33K	33K 1/4W MF	R78	1610-RM4K7	4K7 1/4W MF
R19	1610-RM1K	1K 1/4W MF	R79	1610-RM4K7	4K7 1/4W MF
R20	1610-RM10K	10K 1/4W MF	R80	1610-RM4K7	4K7 1/4W MF
R21	1610-RM10K	10K 1/4W MF	R81	1610-RM4K7	4K7 1/4W MF
R22	1610-RM10K	10K 1/4W MF	R82	1610-RM4K7	4K7 1/4W MF
R23	1610-RM10K	10K 1/4W MF	R83	1610-RM4K7	4K7 1/4W MF
R24	1610-RM10K	10K 1/4W MF	R84	1610-RM4K7	4K7 1/4W MF
R25	1610-RM100K	100K 1/4W MF	R85	1610-RM4K7	4K7 1/4W MF
R26	1610-RM1M	1M 1/4W MF	R86	1610-RM4K7	4K7 1/4W MF
R27	1610-RM1K	1K 1/4W MF	R87	1610-RM4K7	4K7 1/4W MF
R28	1610-RM1M	1M 1/4W MF	R88	1610-RM4K7	4K7 1/4W MF
R29	1610-RM1M	1M 1/4W MF	R89	1610-RM22K	22K 1/4W MF
R30	1610-RM4K7	4K7 1/4W MF	R90	1610-RM47K	47K 1/4W MF
R31	1610-RM1K	1K 1/4W MF	R91	1610-RM1M	1M 1/4W MF
R32	1610-RM4K7	4K7 1/4W MF	R92	1610-RM1K	1K 1/4W MF
R33	1610-RM1M	1M 1/4W MF	R93	1610-RM22K	22K 1/4W MF
R34	1610-RM6K8	6K8 1/4W MF	R94	1610-RM47K	47K 1/4W MF
R35	1610-RM6K8	6K8 1/4W MF	R95	1610-RM4K7	4K7 1/4W MF
R36	1610-RM560R	560R 1/4W MF	R96	1610-RM100K	100K 1/4W MF
R37	1610-RM220K	220K 1/4W MF	R97	1610-RM560R	560R 1/4W MF
R38	1610-RM6K2	6K2 1/4W MF	R98	1610-RM47K	47K 1/4W MF
R39	1610-RM100K	100K 1/4W MF	R99	1610-RM22K	22K 1/4W MF
R40	1610-RM100K	100K 1/4W MF	R100	1610-RM47K	47K 1/4W MF
R41	1610-RM56K	56K 1/4W MF	R101	1610-RM47K	47K 1/4W MF
R42	1610-RM56K	56K 1/4W MF	R102	1610-RM180K	180K 1/4W MF
R43	1610-RM100K	100K 1/4W MF	R103	1610-RM180K	180K 1/4W MF
R44	1610-RM56K	56K 1/4W MF	R104	1610-RM15K	15K 1/4W MF
R45	1610-RM100K	100K 1/4W MF	R105	1610-RM10K	10K 1/4W MF
R46	1610-RM100K	100K 1/4W MF	R106	1610-RM100K	100K 1/4W MF
R47	1610-RM100K	100K 1/4W MF	R107	1610-RM22K	22K 1/4W MF
R48	1610-RM100K	100K 1/4W MF	R108	1610-RM22K	22K 1/4W MF
R49	1610-RM47K	47K 1/4W MF	R109	1610-RM33K	33K 1/4W MF
R50	1610-RM47K	47K 1/4W MF	R110	1610-RM22K	22K 1/4W MF
R51	1610-RM10K	10K 1/4W MF	R111	1610-RM10K	10K 1/4W MF
R52	1610-RM10K	10K 1/4W MF	R112	1610-RM10K	10K 1/4W MF
R53	1610-RM4K7	4K7 1/4W MF	R113	1610-RM1K	1K 1/4W MF
R54	1610-RM4K7	4K7 1/4W MF	R114	1610-RM10K	10K 1/4W MF
R55	1610-RM4K7	4K7 1/4W MF	R115	1610-RM3K3	3K3 1/4W MF
R56	1610-RM4K7	4K7 1/4W MF	R116	1610-RM3K3	3K3 1/4W MF
R57	1610-RM4K7	4K7 1/4W MF	R117	1610-RM10K	10K 1/4W MF
R58	1610-RM4K7	4K7 1/4W MF	R118	1610-RM220R	220R 4W WW
R59	1610-RM4K7	4K7 1/4W MF	R119	1610-RM100K	100K 1/4W MF
R60	1610-RM4K7	4K7 1/4W MF	R120	1610-RM10K	10K 1/4W MF



SERVICE INFORMATION

GP12 MAIN BOARD - COMPONENT PARTS LIST

REF	PART NUMBER	VALUE	REF	PART NUMBER	VALUE
R121	1610-RM560R	560R	C54	1610-C4N7-100VE	4n7 50v M
R122	1610-RM4K7	4K7	C55	1610-C33N-100VE	33nF 50v M
R123	1610-RM4K7	4K7	C56	1610-C3N3-100VE	3n3 50v M
R124	1610-RM6K8	6K8	C57	1610-C22P-50VCD	220pF 50v DC
R125	1610-RM180K	180K	C58	1610-C22N-100VE	22nF 50v M
R133	1610-RM100K	100K	C59	1610-C2N2-100VE	2n2 50v M
C1	1610-CO.47-35VT	0.47uF	C60	1610-C220P-50VCD	220pF 50v DC
C2	1610-C1-35VT	1u5	C61	1610-C10N-100VE	10nF 50v M
C3	1610-C1N-100VE	1nF	C62	1610-C1N-100VE	1nF 50v M
C4	1610-C10-35VER	10uF	C63	1610-C220P-50VCD	220pF 50v DC
C5	1610-C100N-100VE	100nF	C64	1610-C6N8-100VE	6n8 50v M
C6	1610-C10N-100VE	10nF	C65	1610-C680P-63v	680pF 100v P
C7	1610-C10N-100VE	10nF	C66	1610-C100N-100VE	100nF 50v M
C8	1610-C1-35VT	1u5	C67	1610-C100P-50VCD	100pF 100v P
C9	1610-C10-35VER	10uF	C68	1610-C10-35VER	10uF 35v RE
C10	1610-C100N-100VE	100nF	C69	1610-C10-35VER	10uF 35v RE
C11	1610-C100N-100VE	100nF	C70	1610-C10-35VER	10uF 35v RE
C12	1610-C22N-100VE	22nF	C71	1610-C3N3-100VE	3n3 50v M
C13	1610-C1-35VT	1uF	C72	1610-C1N-100VE	1nF 50v M
C14	1610-C1-35VT	1uF	C73	1610-C22-35VER	22uF 35v RE
C15	1610-C22N-100VE	22nF	C74	1610-C1-35VER	1uF 35v RE
C16	1610-C220-35VER	220uF	C75	1610-C1-35VER	1uF 35v RE
C17	1610-C100N-100VE	100nF	C76	1610-C4N7-100VE	4n7 50v M
C18	1610-C100N-100VE	100nF	C77	1610-C1-35VER	1uF 35v RE
C19	1610-C100N-100VE	100nF	C78	1610-C330P-50VCD	330pF 50v DC
C20	1610-C47P-50VCD	47pF	C79	1610-C1-35VER	1uF 35v RE
C21	1610-C47P-50VCD	47pF	C80	1610-C1-35VER	1uF 35v RE
C22	1610-C100N-100VE	100nF	C81	1610-C1-35VER	1uF 35v RE
C23	1610-CO.47-35VT	0.47uF	C82	1610-C10-35VER	10uF 35v RE
C24	1610-CO.47-35VT	0.47uF	C83	1610-C220-35VER	220uF 35v RE
C25	1610-C220P-50VCD	220pF	C84	1610-C220-35VER	220uF 35v RE
C26	1610-C2.2-35VT	2u2	C85	1610-C220-35VER	220uF 35v RE
C27	1610-C1-35VT	1u5	C86	1610-C470P-160V	470pF 100v P
C28	1610-C22N-100VE	22nF	C87	1610-C100N-100VE	100nF 50v M
C29	1610-CO.33-35VT	0.33uF	C88	1610-C2.2-35VT	2u2 35v T
C30	1610-C220P-50VCD	220pF	C89	1610-C2.2-35VT	2u2 35v T
C31	1610-C2.2-35VT	2u2	C90	1610-C22-35VER	22uF 35v RE
C32	1610-CO.33-35VT	0.33uF	C91	1610-C220-35VER	220uF 35v RE
C33	1610-C220P-50VCD	220pF	C92	ON FRONT BOARD	
C34	1610-C1-35VT	1u5	C93	1610-C100N-100VE	100nF 50v M
C35	1610-CO.22-35VT	0.22uF	C94	1610-C1000-63VEA	1000uF 63v AE
C36	1610-C220P-50VCD	220pF	C95	1610-C1-35VER	1uF 35v RE
C37	1610-C1-35VT	1uF	C96	1610-C4N7-100VE	4n7 50v M
C38	1610-C100N-100VE	100nF	C97	1610-C100N-100VE	100nF 50v M
C39	1610-C220P-50VCD	220pF	TR1	1610-TBC549C	BC549C
C40	1610-CO.47-35VT	0.47pF	TR2	1610-TBC549C	BC549C
C41	1610-C100N-100VE	100nF	TR3	1610-TBC549C	BC549C
C42	1610-C10N-100VE	10nF	TR4	1610-TBC549C	BC549C
C43	1610-C47-100VE	47nF	TR5	1610-TBC549C	BC549C
C44	1610-C220P-50VCD	220pF	TR6	1610-TBC549C	BC549C
C45	1610-CO.33-35VT	0.33uF	TR7	1610-TBC549C	BC549C
C46	1610-C33N-100VE	33nF	TR8	1610-TBC549C	BC549C
C47	1610-C220P-50VCD	220pF	TR9	1610-TBC549C	BC549C
C48	1610-CO.22-35VT	0.22uF	TR10	1610-TBC549C	BC549C
C49	1610-C15N-100VE	15nF	TR11	1610-TBC549C	BC549C
C50	1610-C220P-50VCD	220pF	TR12	1610-TBC549C	BC549C
C51	1610-C100N-100VE	100nF	TR13	1610-TBC549C	BC549C
C52	1610-C6N8-100VE	6n8	TR14	1610-TBC549C	BC549C
C53	1610-C220P-50VCD	220pF	TR15	1610-TBC549C	BC549C



SERVICE INFORMATION

GP12 MAIN BOARD - COMPONENT PARTS LIST - FRONT BOARD

REF	PART NUMBER	VALUE	REF	PART NUMBER	VALUE
TR16	1610-TBC549C	BC549C	R126	1610-RM6K8	6K8 1/4W
TR17	1610-TBC549C	BC549C	R127	1610-RM15K	15K 1/4W
TR18	1610-TBC549C	BC549C	R128	1610-RM4K7	4K7 1/4W
TR19	1610-TBC549C	BC549C	R129	1610-RM15K	15K 1/4W
TR20	1610-TBC549C	BC549C	R130	1610-RM220R	220R 1/4W
TR21	1610-TBC549C	BC549C	R131	1610-RM220R	220R 1/4W
TR22	1610-TBC549C	BC549C	R132	1610-RM1K5	1K5 1/4W
TR23	1610-TBC549C	BC549C			
TR24	1610-TBC549C	BC549C	C92	1610-C1035VEA	10uF 35v
D1	1610-D-1N4148	1N4148	P1	1610-PRESET-4K7	4K7 PRESET
D2	1610-D-1N4148	1N4148	SL1 -	1611-SLIDER-S	100K LIN SLIDER
D3	1610-D-1N4148	1N4148	SL13		
D4	1610-D-1N4148	1N4148			
D5	1610-D-1N4148	1N4148	TR25-	1610-TBC549C	BC549C
D6	1610-D-1N4148	1N4148	TR29		
D7	1610-D-1N4148	1N4148			
D8	1610-D-1N4148	1N4148	L1	1610-LED GREEN	LED 5MM GREEN
D9	1610-D-1N4148	1N4148	L2	1610-LED-YELLOW	LED 5MM YELLOW
D10	1610-D-1N4148	1N4148	L3	1610-LED-RED	LED 5MM RED
D11	1610-D-1N4148	1N4148	L4	1610-LED-RED	LED 5MM RED
D12	1610-D-1N4148	1N4148	L5	1610-LED-RED	LED 5MM RED
D13	1610-D-1N4148	1N4148			
D14	1610-D-1N4148	1N4148			
ZD1	1610-D-BZY88C15	BZY88C15	SW1	1610-SW-D6	D6 PLUNGER SWITCH
ZD2	1610-D-BZY88C33	BZY88C33	SW2	1610-SW-D6	D6 PLUNGER SWITCH
T1	1612-TRANS-DI	D.I. TRANSFORMER	MISCELLANEOUS PARTS		
IC1	1610-IL-TL072	TL072	SLIDER CAP WHITE		1605-CAP-SLIDE-W
IC2	1610-IC-4066BPC	CD4066B	SLIDER CAP RED		1605-CAP-SLIDE-R
IC3	1610-IC-4011BPC	CD4011B	COLLET KNOB BLACK		1611-RITEL-KNOB
IC4	1610-IC-4066BPC	CD4066B	COLLET KNOB CAP RED		1611-RITEL-CAP-R
IC5	1610-IL-TL072	TL072	COLLET KNOB CAP GREEN		1611-RITEL-CAP-G
IC6	1610-IL-TL072	TL072	X.L.R. CHASSIS PLUG		1611-XLR-PM
IC7	1610-IL-TL072	TL072	FRONT OVERLAY		1614-OLAY-GP12
SW1	1610-SWF2UEE	LATCH PUSH SWITCH	PUSH SWITCH CAP WHITE		1605-CAP-SWT-6
SW2	1610-SWF2UEE	LATCH PUSH SWITCH	INPUT GAIN POT 500K		1611-POT-500K
SK1	1610-HEADER-6W	PIN HEADER 6 WAY	OUTPUT LEVEL POT 50K		1611-POT-50K
J1	1611-JCK-BNNG	MONO JACK-BNB	I.C. SOCKET 8 PIN		1600-SOCKET-8W
J2	1611-JCK-BNNG	MONO JACK-BNB	I.C. SOCKET 14 PIN		1600-SOCKET-14W
J3	1611-JCK-BNNG	STEREO JACK-BBB	LED REFLECTOR		1605-LED-REFLECT
J4	1611-JCK-BNNG	MONO JACK-BNB	BD677 HEATSINK		1611-MS-GP12
J5	1611-JCK-BNNG	MONO JACK-BNB	SYMBOLS USED IN PARTS LIST		
J6	1611-JCK-BNNG	MONO JACK-BNB	MF		METAL FILM RESISTOR
J7	1611-JCK-BNNG	MONO JACK-BNB	WW		WIRE WOUND RESISTOR
J8	1611-JCK-BNNG	STEREO JACK-BBB	M		MYLAR CAPACITOR
JL1	1610-LINK-10W	JUMPER LINK 10 WAY	T		TANTALUM CAPACITOR
JL2	1610-LINK-10W	JUMPER LINK 10 WAY	DC		DISC CERAMIC CAPACITOR
JL3	1610-LINK-10W	JUMPER LINK 5 WAY (CUT IN 2 PIECES)	P		POLYESTER CAPACITOR
JL4	1610-HEADER-3W	PIN HEADER 3 WAY	RE		RADIAL ELECTROLYTIC
			AE		AXIAL ELECTROLYTIC

PARTS LIST FOR PB200 POWER MODULES

Description	Part Code	Qty	Where Used
RESISTORS			
100K ¼ WATT	72-RM100K	1	R8
15K ¼ WATT	72-RM15K	1	R16
220R ¼ WATT	72-RM220R	8	R9-15 R19
4K7 ¼ WATT	72-RM4K7	3	R2 R3 R5
560R ¼ WATT	72-RM560R	1	R6
56K ¼ WATT	72-RM56K	2	R1 R7
68K ¼ WATT	72-RM68K	1	R4
10R 2.5 WATT	72-RWW10R-2.5W	1	R17
1K 2W PLUGABLE	72-RWW1K	1	R18
CAPACITORS			
0.22µF 250V POLY BOX	72-C0.22-250VP	1	C11
1.5µF 35V TANT	72-C1.5-35VT	1	C1
100nF 250V POLY BOX	72-C100N-250VP	1	C8
10nF 100V MYLAR	72-C10N-100VE	1	C7
220pF 100V CER DISC	72-C220P-100VCD2	1	C2
47µF 63V RADIAL	72-C47-63VER	2	C4 C12
47pF 100V CER DISC	72-C47P-100VCD	3	C3 C5 C6
4700µF 80V RADIAL	72-CAP-470080V	2	C9 C10
SEMI-CONDUCTORS			
12V ZENER DIODE	72-D-BZX55C12V	2	ZD3 ZD4
39V ZENER DIODE	72-D-BZX55C39V	2	ZD1 ZD2
GI 751 DIODE	72-D-GI751	4	D6-9
IN4148 DIODE	72-D-IN4148	5	D1-5
BUZ900 MOSFET	72-MOS-BUZ900	2	
BUZ905 MOSFET	72-MOS-BUZ905	2	
BF422 TRANSISTOR	72-TBF422	2	TR4 TR5
BF423 TRANSISTOR	72-TBF423	3	TR1-3
OTHERS			
ISOLATION BUSH	72-MOS-BUSH-WHT	8	
ISOLATION PAD	72-MOS-KOOL-PAD	4	
220R PRESET POT	72-PRESET-220R	1	P1
MAIN HEATSINK	71-HS-L200	1	

Rik Daniels
April 3, 1997

GP12/1

GP12 PREAMPLIFIER

The **GP12** preamplifier is used in the following **Trace Elliot Series 6** products:

Amplifier Heads: AH200, AH300, AH500, VA400

Combo amplifiers: 1210, 1215

Rack Mount Equipment: GP12X

TECHNICAL SPECIFICATIONS

Inputs	Passive Bass	Impedance 100k Ohms Input Range 50mV to 10V (peak-peak)
	Active Bass	Impedance 10k Ohms Input Range 100mV to 20V (peak-peak)
	Effects Return	Impedance 50k Ohms Nominal Input Level 0dBv (0.775v RMS)
	Line Input	Impedance 50k Ohms Nominal Input Level 0dBv
Outputs	Effects Send	Impedance 10k Ohms Nominal Level 0dBv
	Line Output	Impedance 600 Ohms Nominal Level 0dBv Maximum Level +9dBv (7v RMS)
	DI Output	600 Ohms, Transformer Balanced Nominal Level 0dBv (Pins 2& 3)
Equalisation	Graphic	+/- 15dB at 12 centre frequencies
	Mid Pre Shape	+6dB at 50 Hz and 2kHz, -6dB at 400 Hz
Frequency Response		-3dB at 22 Hz and 25kHz
Signal/Noise Ratio		Better than 80dB (EQ flat, Mid out)
Distortion		Less than 0.05% THD

GP12/2

GP12 CIRCUIT DESCRIPTION

INPUT J1/J2

J1 and J2 are the instrument inputs to the GP12. A signal entering J1 is passed to the first stage via R2 with R1 in parallel. Resistor R12 is to decouple any D.C. appearing on the input to ground.

A signal entering J2 is passed to the first stage via R1, again with R12 as a D.C. path to ground. This time however, R2 has one end connected to ground via the switched contact on J1. This provides a degree of attenuation to the "Active Bass" input J2 with the combination of R1 and R2 acting as a potential divider across the input.

FIRST STAGE

The first stage is made up of transistors TR1 and TR2. TR2 is an "emitter follower" stage to provide a low impedance output to feed the next stage (the Mid Pre Shape circuit).

TR1 is the input gain/attenuation stage with its level controlled by the "input Gain" pot. Gain is achieved by moving the pot's wiper toward the input and attenuation by moving the wiper to the opposite end, providing negative feedback from the collector to the base of TR1.

The supply to this first stage comes in via R8 and is decoupled with C4 to prevent any power supply noise from reaching this sensitive input circuit. C3 is to bypass any high frequency noise and prevent radio breakthrough, etc.

MID PRE SHAPE

The combination of C5, C6, C7 and C96, along with resistors R13, R14 and R16 form a "Band Reject" filter. This provides a "Mid Cut" to any signal passing through it. The filter is buffered by one half of IC1.

The "Mid Pre Shape" switching is performed by IC2 and an analog switch on the input to the second half of IC1. By closing one of these switches either the "Straight" sound via R15 or the "Pre Shaped" sound via R17 may be selected. These two resistors also set the gain of the following stage with a greater gain being provided by the smaller value of R17. As this is in the output from the "Pre Shape" circuit it provides a "Top" and "Bottom" boost as well as a "Mid" cut to the "Pre Shaped" sound.

As long as the D.C. voltage on the input to the analog switches is the same, the switching will be click free. This voltage is provided from the emitter of transistor TR2.

THE GRAPHIC SECTION

The graphic equalisation section is configured around IC5. The input signal comes from the output of IC2 Pin 7 via R45 into the first half of the graphic.

The graphic is split into two halves with each covering six frequency bands. The signal from the first half (IC5 Pin 1) is passed to the second half by resistor R48.

Each frequency band of the graphic is composed of one transistor, two capacitors and three resistors, forming a resonant circuit. Taking the 10kHz band as an example, the transistor is TR20, the resistors are R83, R84 and R85, and the two frequency determining capacitors are C61 and C62.



SERVICE INFORMATION

GP12/3

This circuit presents a low impedance to the slider of the graphic pot SL11 at its 10kHz centre frequency. Thus, moving the slider down reduces the amount of signal at this frequency reaching Pin 5 of IC5 (the non-inverting input) producing a "Cut" at 10kHz, whereas moving the slider up reduces the amount of feedback via R47 back into Pin 6 of IC5, increasing the gain at 10kHz, producing a "Boost".

The 220pF capacitor C60 is included to increase the stability of the resonant circuit. The two 47pF capacitors C20 and C21 help to prevent any high frequency oscillation or R.F. pick-up.

The output of the graphic stage comes from IC5 Pin 7 and is fed back into the Graphic/Flat balance control circuit.

GRAPHIC/FLAT BALANCE CIRCUIT

The signal from the graphic stage is fed into the circuit via C23 and R49 to one end of the Graphic/Flat balance slider. The other end of the slider is fed with the signal from the "Mid Pre Shape" circuit IC1 Pin 7. The wiper of the slider goes to ground so that moving the slider from one end to the other will attenuate either the signal from the graphic or the signal from before the graphic, allowing a balance between these two signals to be set.

The output from this circuit is via R51 and R52 and is at the correct level to go to the effects send socket.

GRAPHIC IN/OUT SWITCHING

C88 and C89 connect the signals from either end of the balance slider into the two analog switches. Closing one or other of these will short out any A.C. signal present to ground allowing through only that signal which has not been shorted - i.e. it selects the signal from either before or after the graphic stage, thus switching the graphic in and out.

The other side of the analog switches are connected to ground as far as A.C. is concerned by capacitor C90, but are actually biased up to a D.C. voltage of 7.5 volts. This is necessary to allow the analog switches to function correctly.

NOISE REDUCTION

The signal from IC1 Pin 7 is fed via C66 and R89 into the first half of IC6 where it is boosted in level. R90 feeds this signal to the non-inverting input of a comparator stage, with the threshold of the comparator being set by the potential divider R92/R93 supplying a fixed level to the inverting input.

Each time the signal from R90 goes above this threshold, the output on Pin 7 swings from -ve supply to +ve supply. This biases on transistor TR23 which in turn discharges capacitor C69 quickly via R97.

Once transistor TR23 has turned off, then C69 will slowly recharge via R96. This charging and discharging of C69 brings the noise reduction "In" and "Out" in the following way.

The diode chain D8 to D13 will normally appear as an open circuit to A.C. signals unless it is forward biased, when it appears as a short circuit. As C69 slowly charges up, it also charges up C70 via R99. This rising voltage gradually forward biases the diodes and when the noise reduction switch is closed, this will add a progressive "Top" cut by putting C74 directly across the signal path. However, when C69 quickly discharges, this instantly removes the effect of capacitor C74, removing the noise reduction.

It can be seen from this description that the noise reduction comes in gradually when no signal is present and is removed instantly as soon as any signal is present at the input.



SERVICE INFORMATION

GP12/4

SIGNAL LEVEL INDICATION

Transistors TR7, TR8 and TR9 are fed from three separate points throughout the GP12. These three transistors then combine to feed the level indication circuit. In this way, the level is monitored at all the critical points in the GP12 ensuring that clipping or distortion cannot take place without the level indication circuit detecting it.

The combined output of these three transistors is a varying D.C. voltage that is developed across capacitor C92, feeding the voltage divider chain of R126, R128 and P1, with P1 adjusting the point at which the red "Overload" LED comes on. When the voltage across C92 reaches a high enough level, it will bias on transistor TR25, lighting the "Increase Gain" LED. As the voltage increases, it will bias on transistor TR26, lighting the "OK" LED. This will also cause the transistor TR28 to be turned off, making the "Increase Gain" LED go out. As this voltage again increases, the "Overload" LED will be lit by transistor TR27 and the "OK" LED will be turned off by TR29.

THE OUTPUT STAGE

The signal from the "Effects Return" socket is passed via C75 and R105 to the first half of IC7. This stage has a gain of 10 in order to return the signal back to line level. This then feeds the "Output Level" pot and the "Post EQ" D.I. stage.

C76 and R125 are for high frequency compensation purposes, with C80, C95 and R123 forming a "High Pass" filter to set the low frequency roll off for the pre amp output. R111 and R112 form a potential divider across the supply for biasing up IC7 to half this voltage. C82 decouples this half supply point to ground.

The "Output Level" pot sets the level of signal passed to the final stage, formed around the second half of IC7. This feeds the "Line Out" socket as well as the signal output to the PCB connector socket. The "Line Input" socket feeds into the non-inverting input on this op amp (Pin 3) to be mixed with the pre amp signal. C78 sets the high frequency limit of the output from the GP12 and R109 sets the gain of this final stage.

PREAMP SUPPLY REGULATION

The supply voltage comes into the GP12 PCB on connector Pin 4. This voltage is dropped across R118 to a suitable level for the regulator transistor TR24. C94 helps to smooth out any ripple on the incoming supply.

TR24 (the BD677) is working as a series regulator with its output voltage being set with a 33 volt zener diode in its base. The voltage across the zener diode is provided by resistor R117, with any noise produced by the zener being decoupled by C83.

The output voltage from the regulator is dropped across the potential divider R115 and R116 to provide a half supply reference to the op amps in the preamp. C84 and C85 hold this voltage stable.

D.I. PROTECTION CIRCUIT.

The D.I. switch selects the signal from either before the graphic but after the "Mid Pre Shape" (Pre EQ), or from after the graphic and after the Effects Return (Post EQ). This signal is passed to the D.I. drive transistor TR22. This directly drives the transformer T1 to provide the balanced and isolated D.I. output.

R103 and R103 bias the transistor base to half supply, R104 sets the D.C. conditions on the emitter, C72 is high frequency bypass and C73 couples the AC signal through to drive the transformer.



SERVICE INFORMATION

GP12/5

GRAPHIC AND PRE SHAPE SWITCHING

Both the graphic and the pre shape switching circuits operate in the same way. Taking the graphic switching as an example, we have two of the NAND gates of IC3, one analog switch from IC2 and a transistor TR4 that form the actual switching circuit. TR6 is there to turn on or off the status LED on the pre amp and in the foot switch.

The supply to the switching circuit is zenered down to 15v by ZD11. This also provides the supply to IC2 and IC4, the analog switches. On power up, capacitor C14 will be in a discharged state and will hold the voltage on Pin 3 of IC13 low. This will mean that the output on Pin 11 is high, which is in turn connected to Pins 8 and 9, resulting in Pin 10 being low. Pin 10 is connected back via R31 to Pin 12. Pin 11 (high) is connected via R32 to the base of Transistor TR6. This transistor will turn on, lighting LED L4 and the LED in the foot switch if connected. By the time C14 has charged up, circuit conditions will have stabilised. This ensures that the circuit always comes on in a known condition - graphic in, pre shape out.

The switching over of the circuit is accomplished every time the analog switch IC2 (Pins 8 and 9) is closed. From our initial condition, Pins 8 and 9 of IC3 are high. This will charge up the capacitor C15 via R33 making Pin 8 on IC2 high also. Closing the analog switch takes Pin 12 of IC3 high and, as Pin 13 is already high, then Pin 11 will go low, Pins 8 and 9 will go low and Pin 10 will go high, holding Pin 12 high and maintaining the conditions. The circuit has now changed state and LED 4 will go out as TR6 turns off.

Pins 8 and 9 are now low so C15 will be discharged via R33. Pin 8 on IC2 will also be low so that when the analog switch is again closed, the circuit will change back to its initial state.

The analog switch is operated by transistor TR4, the base of which is held high by R23. Its collector will therefore be low. However, when push button SW1 is closed, this pulls the base of TR4 down via D4 to 0.6 volts - the same as the voltage set on its emitter by diode D1, thus turning TR4 off. The collector of TR4 will go high closing the analog switch and, as we have previously seen, this will change the state of the circuit. The same will occur if the foot switch is operated.

The LEDs in the foot switch and on the front panel of the GP12 are in fact in parallel and have 220 Ohm resistors in series with them to ensure even brightness.