

TOSHIBA

STEREO AMPLIFIER

SB-A10

000562

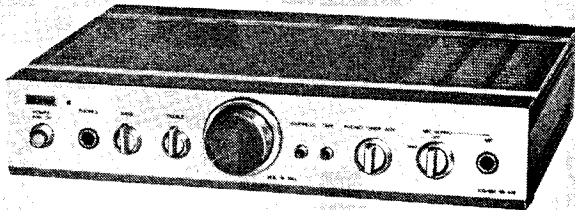

For Service Manuals Contact
MAURITRON TECHNICAL SERVICES
 8 Cherry Tree Rd, Chinnor
 Oxon OX9 4QY
 Tel:- 01844-351694 Fax:- 01844-352554
 Email:- enquiries@maurifron.co.uk

SPECIFICATIONS

Power Output
 40 Hz ~ 20 kHz both channels driven: 2 x 20 W, 8 ohms
 1 kHz both channel driven: 2 x 22 W, 8 ohms
 2 x 24 W, 4 ohms

Total Harmonic Distortion: at 8 ohms
 Rated power output: 0.1%
 1 W: 0.08%

Intermodulation Distortion: 0.1%
Damping Factor: 50

Input (Sensitivity/Impedance)
 PHONO: 2.5 mV/47K ohms
 TUNER/AUX: 150 mV/47K ohms
 TAPE: 150 mV/47K ohms
PHONO Overload Level: 180 mV/rms at 1 kHz
Output Level
 TAPE REC: 150 mV

Frequency Response
 PHONO (RIAA Equalization): 30 Hz to 20 kHz ± 0.3 dB
 AUX, TAPE: 30 Hz to 35 kHz $\begin{matrix} + 0 \\ - 1.5 \end{matrix}$ dB

Tone Controls:
 BASS: ± 10 dB (100 Hz)
 TREBLE: ± 10 dB (10 kHz)
Loudness Contour: +8 dB (100 Hz)
 +4 dB (10 kHz)

Signal to Noise Ratio
 (IHF short-circuited A network, rated power)
 PHONO: 75 dB
 AUX, TAPE: 90 dB

■ **GENERAL**
Power Supply: 220V 50 Hz ~ or 240V 50 Hz ~
Power Consumption: 180W
Weight: 3 kg
Dimensions (W x H x D): 257 x 54 x 208 (mm)

Specifications are subject to change without notice.

TE, TU, AY

1. OPERATING CONTROLS

FRONT VIEW

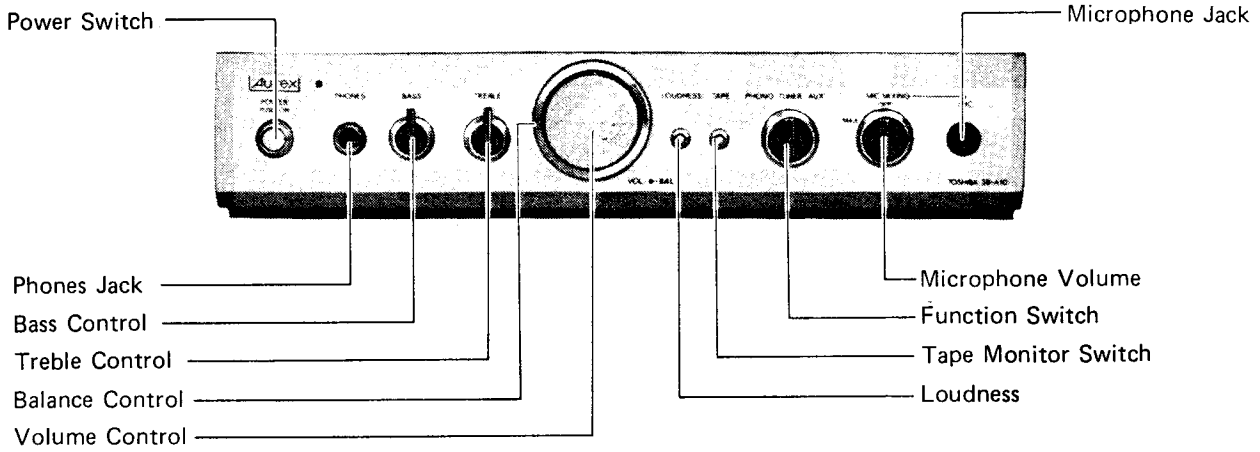

Figure 1.

REAR VIEW

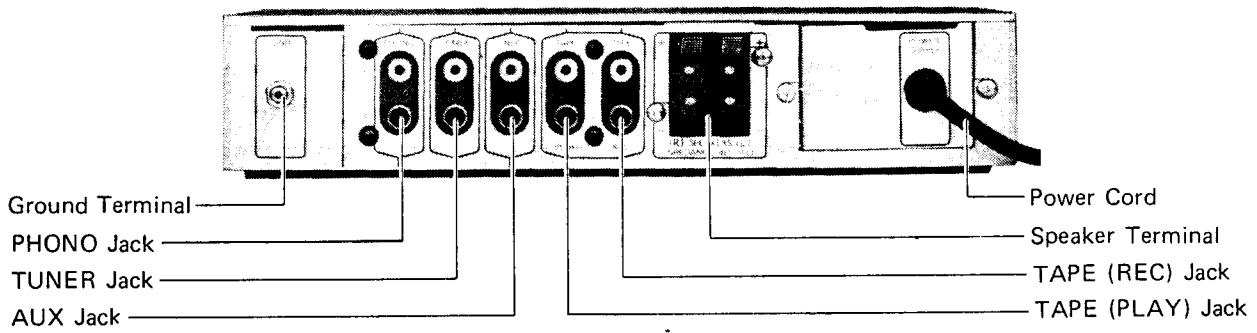

Figure 2.

2. DISASSEMBLY INSTRUCTIONS

PANEL REMOVAL

1. Remove the four knobs ①, ②, ③. See Figure 3.
2. Remove seven screws ④, ⑤, ⑥. See Figure 4.
3. Draw the front panel toward you as shown in Fig. 5. Remove the front panel by detaching the LED P.C. Board. See Figure 5.

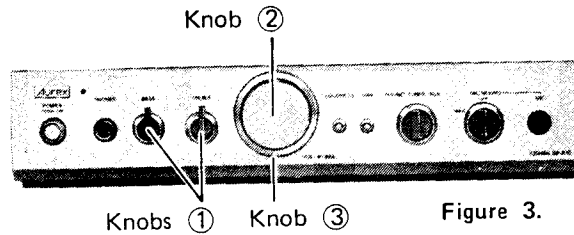

Figure 3.

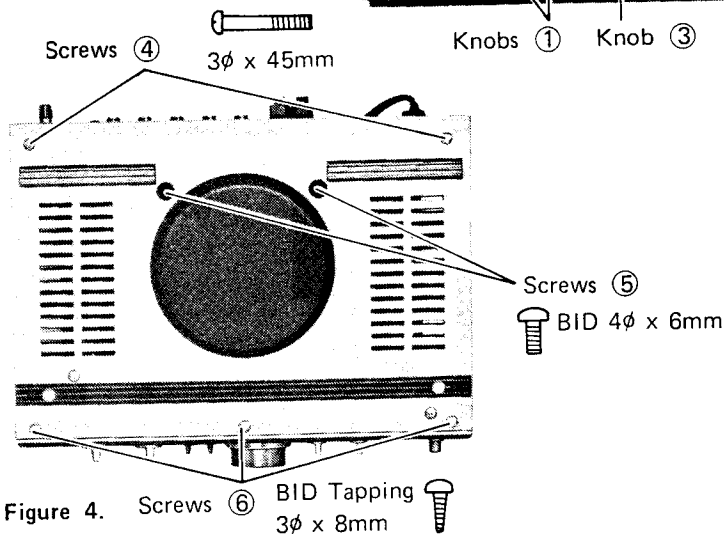
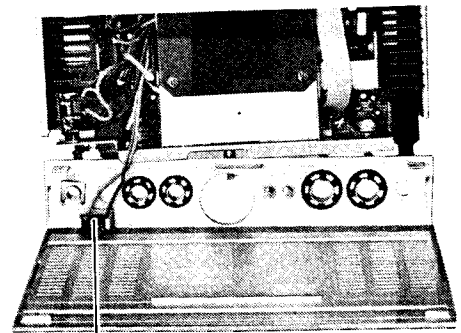

Figure 4.



LED P.C. Board

Figure 5.

CHASSIS REMOVAL

1. Remove two screws ⑦. See Figure 6.
2. Remove seven screws ⑧, ⑨. See Figure 7.
3. Lift up the chassis as shown in Fig. 8 and remove the chassis.

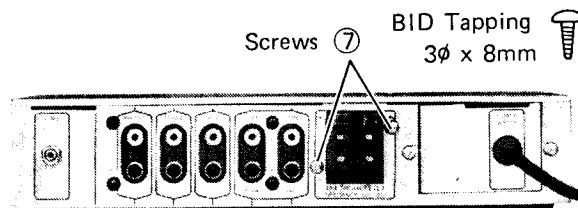

Figure 6.

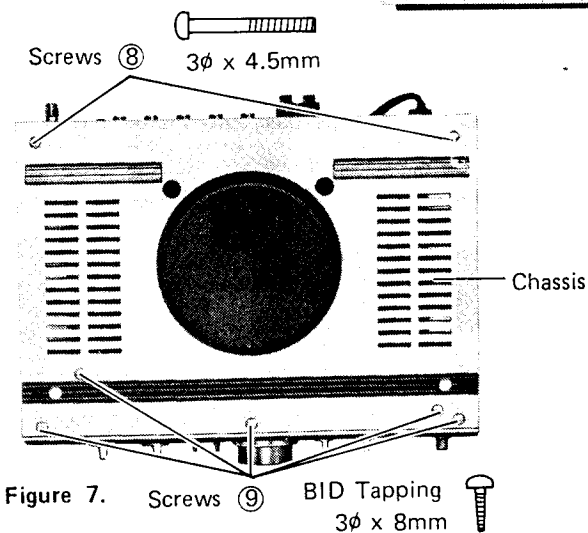

Figure 7.

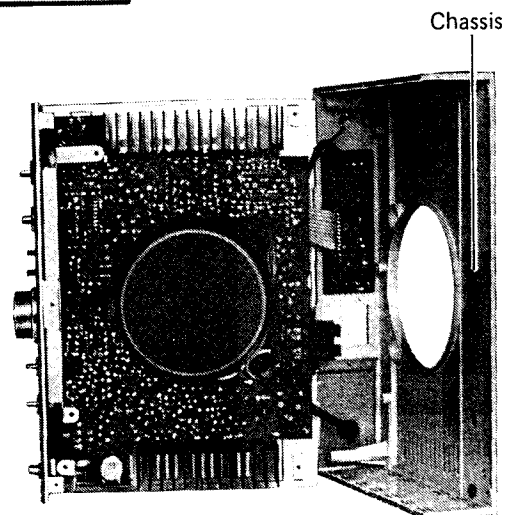

Figure 8.

For Service Manuals Contact
MAURITRON TECHNICAL SERVICES
 8 Cherry Tree Rd, Chinnor
 Oxon OX9 4QY
 Tel: 01844-351694 Fax: 01844-352554
 Email: enquiries@mauritron.co.uk

3. REPLACEMENT OF CHIP PARTS

1. Use substitutions whose parts numbers are indicated in the parts list when replacing chip parts.

2. REMOVING CHIP PARTS

Melting solder on both ends of chip parts with a soldering iron and remove it by turning with tweezers as shown in figure 9.

- NOTE: 1) Confirm the constant of chip resistors by in-circuit resistance value.
 2) Never use the chip parts removed again.

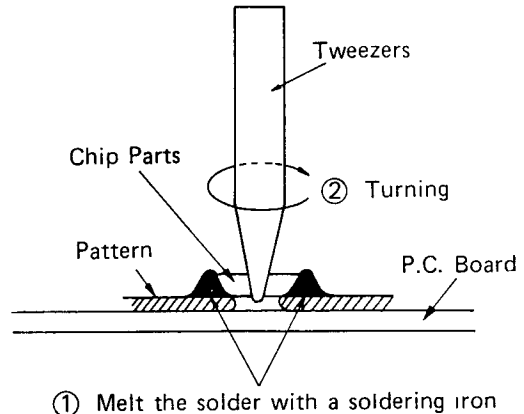

Figure 9.

4. BLOCK DIAGRAM

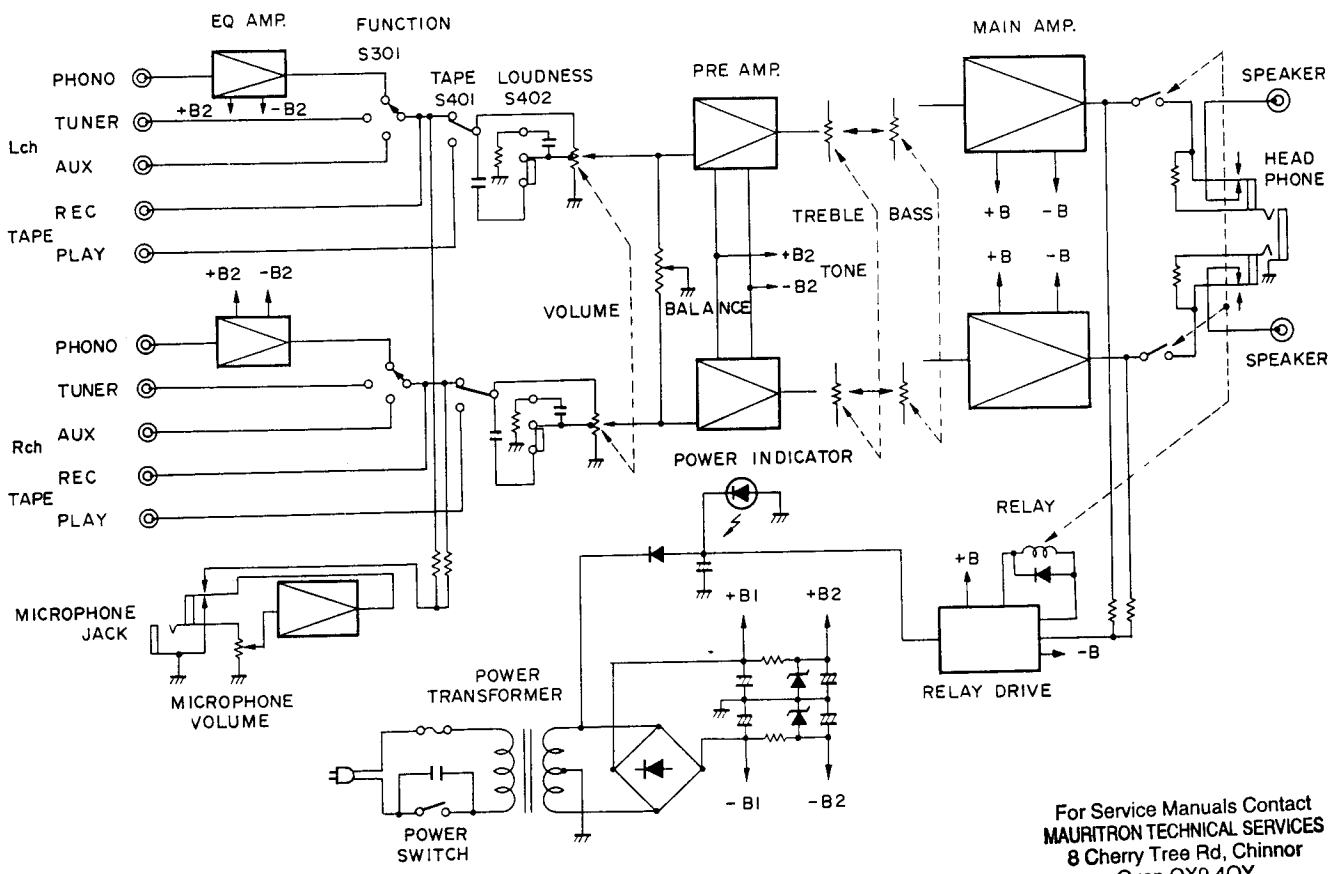

Figure 10.

For Service Manuals Contact
MAURITRON TECHNICAL SERVICES
 8 Cherry Tree Rd, Chinnor
 Oxon OX9 4QY
 Tel:- 01844-351694 Fax:- 01844-352554
 Email:- enquiries@mauritron.co.uk

5. ELECTRICAL PARTS LOCATIONS

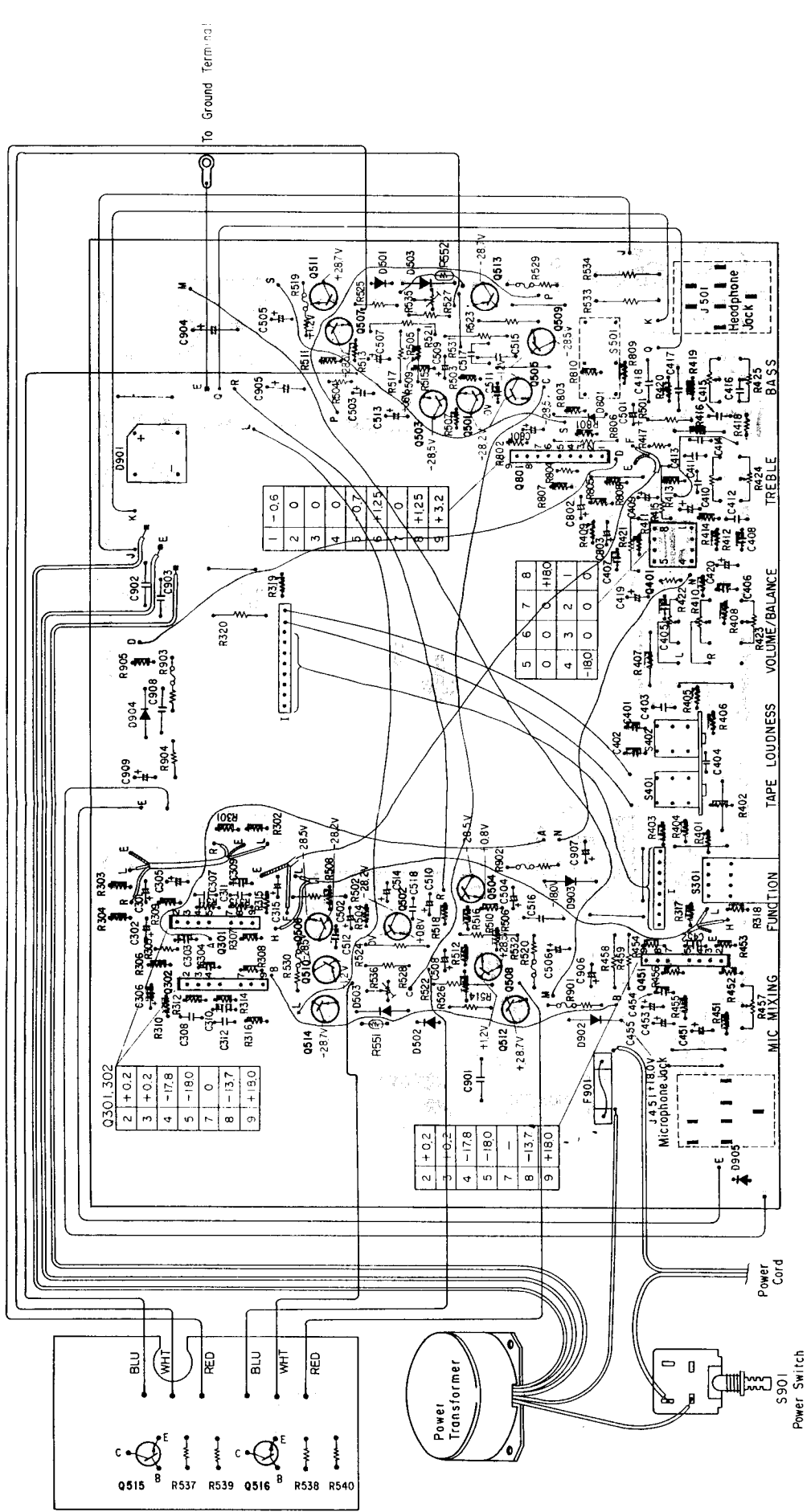

Figure 11.

Symbol No.	R301	R303	R306	R307	R309	R311	R313	R315	R317	R319	R401	R403	R405	R408	R409	R411	R413	R416	R419	R451	R452
L	48K	33K	33K	12K	27K	15K	14K	65K	4.5K	5K	1K	8.5K	2K	6K	16K	3K	2.8K	1.8K	2K	2K	15K
H	46K	33K	33K	40K	27	15K	15K	100K	4.5K	5K	5K	1K	8.5K	2K	6K	32K	3K	2.8K	1.8K	2K	100K

Symbol No.	R453	R454	R456	R503	R507	R511	R513	R515	R518	R601	R602	R603	R605	R607	R608	R610	R605	
L	340	760	30K	10K	1.6K	550	2.5K	3.5K	44K	550	18K	11.5K	8K	12K	55K	28K	30K	38K
H	340	760	200K	45K	22K	1.6K	1.6K	2.5K	3.5K	550	18K	20K	13.5K	55K	12.5K	34K	40K	70K

As the resistance value of each chip resistor varies by the polarity of circuit tester, the minimum and maximum value are indicated at power off condition.

L = (or means) minimum value
 H = (or means) maximum value

CAUTION: ON P.C. BOARD HANDLING
 1) Avoid vibration and shock.
 2) Do not bend and twist.

SB-A10 SB-A10

6. SCHEMATIC DIAGRAM

For Service Manuals Contact
MAURITRON TECHNICAL SERVICES
 8 Cherry Tree Rd, Chinnor
 Oxon OX9 4QY
 Tel: 01844-351894 Fax: 01844-352554
 Email: enquiries@maurtron.co.uk

- NOTES
1. S301 : Rotary switch for Function (PHONO Position)
 2. S401 : Push switch for Tape and Loadless (OFF Position)
 3. S501 : Relay switch for ON/OFF (OFF Position)
 4. S901 : Push switch for Power (OFF Position)
 5. Mark * indicates chip parts.

CAUTION: The Δ mark, the symbol No. circled with rectangle in the schematic diagram and the shaded area in the parts list designate components which have special characteristics important for safety and should be replaced only with types identical to those in the original circuit or specified in the parts list.

Figure 12.

— 6 —

7. ADJUSTMENTS

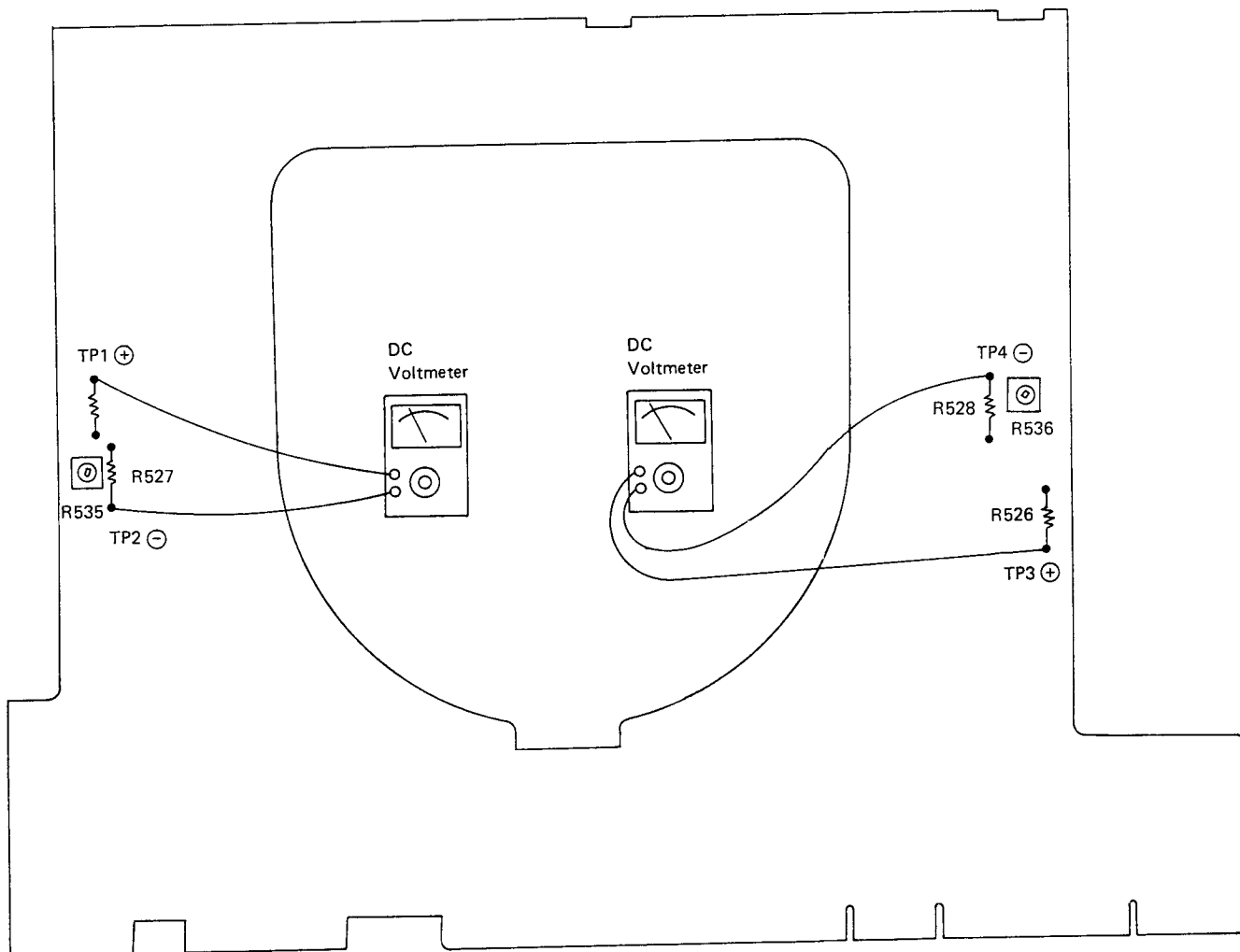

Figure 13. Top View of P.C. Board

■ IDLE CURRENT ADJUSTMENT

Set the Function Switch to PHONO Position, Tape Monitor Switch to OFF Position, Loudness Switch OFF Position and Volume Control Knob MINIMUM Position.

■ LEFT CHANNEL

1. Connect a DC Voltmeter (test range 0.3V) to test Points TP1(+) and TP2(-).
2. Adjust the Semi-fixed Resistor (R535) for 10mV.
3. Proceed with the adjustment in 60 seconds after the Power Switch is turned on.

■ RIGHT CHANNEL

1. Connect a DC Voltmeter (test range 0.3V) to test Points TP3(+) and TP4(-).
2. Adjust the Semi-fixed Resistor (R536) for 10mV.
3. Proceed with the adjustment in 60 seconds after the Power Switch is turned on.

8. CABINET PARTS LOCATIONS

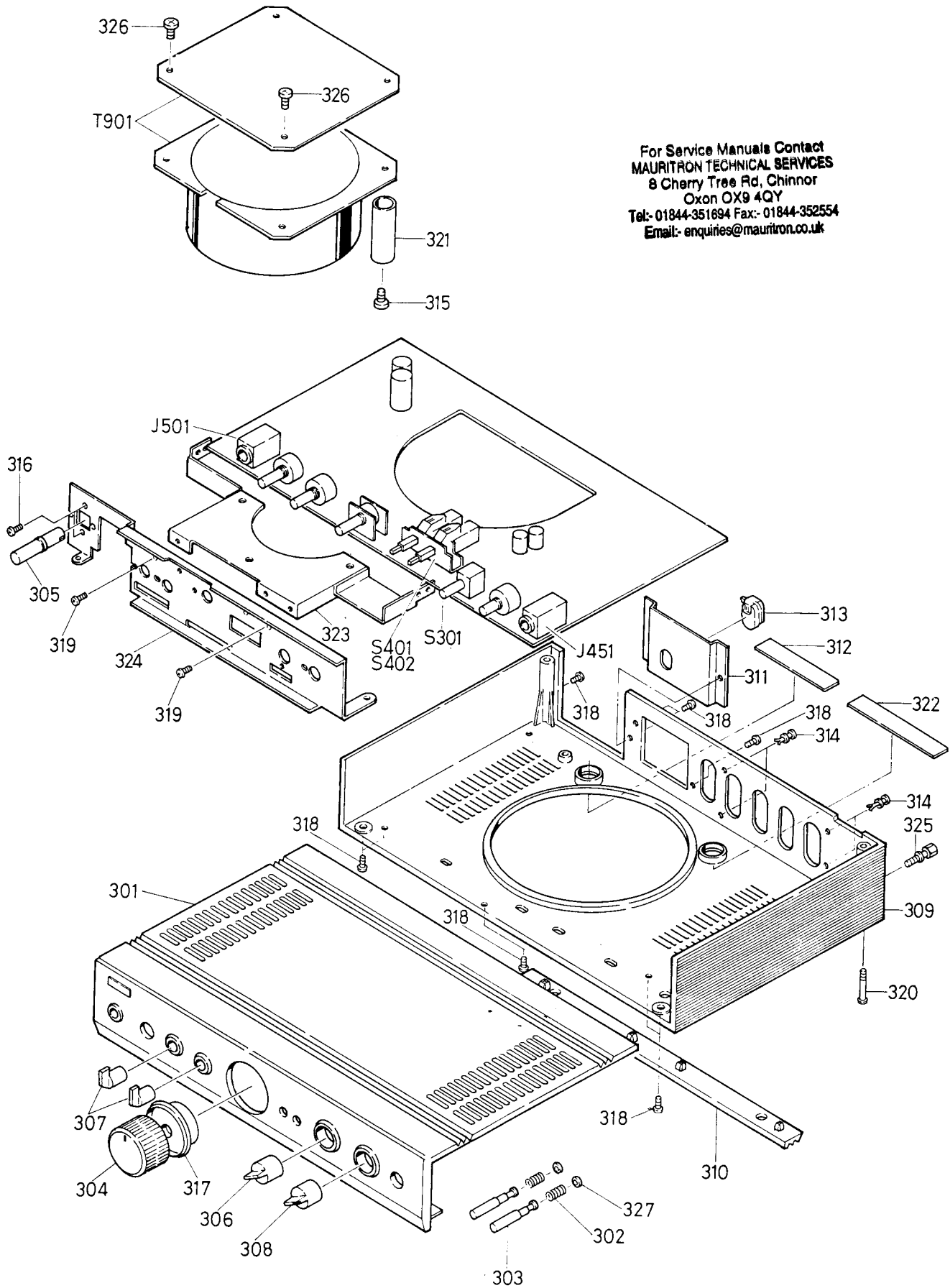

For Service Manuals Contact
MAURITRON TECHNICAL SERVICES
 8 Cherry Tree Rd. Chinnor
 Oxon OX9 4QY
 Tel:- 01844-351694 Fax:- 01844-352554
 Email:- enquiries@mauritron.co.uk

Figure 14.

9. PARTS LIST

CAUTION: The \triangle mark, the symbol No. circled with rectangle in the schematic diagram and the shaded area in the parts list designate components which have special characteristics important for safety and should be replaced only with types identical to those in the original circuit or specified in the parts list.

Symbol No.	Part No.	Description
CABINET PARTS		
301	22821491	Panel Ass'y
302	25772471	Spring, Push Knob
303	25837237	Knob, Push (TAPE/ LOUDNESS)
304	22826257	Knob, Volume
305	22824329	Knob, Power
306	22826223	Knob, Function
307	22826269	Knob, Lever (BASS/TREBLE)
308	22826264	Knob, Microphone Level
309	22831577	Chassis
310	22874045	Leg
312	22864305	Nameplate (TE)
312	22864308	Nameplate (TU, AY)
313	25845528	Bushing, Power Cord
314	22705026	Rivet, 3 ϕ x 6.5mm
315	22707040	Screw (BID), 4 ϕ x 6mm
316	22707066	Screw (BID), 3 ϕ x 6mm
317	22826255	Knob, Balance
318	22707327	Screw (BID), 3 ϕ x 8mm, Tapping
319	22701326	Screw (BID), 3 ϕ x 8mm, Tapping
320	22707328	Screw (BID), 3 ϕ x 45mm
321	22830137	Stud
322	22864306	Label, Caution
325	22162327	Terminal, Ground
326	22707467	Screw (BID), 4 ϕ x 8mm, Tapping
327	25764536	Washer, Nylon, Push Knob
ICS, TRANSISTORS AND DIODES		
Q301, 302		IC, TA7322P
Q401	22114594	IC, NJM4558D-K
Q451		IC, TA7322P
Q501, 502		Transistor, 2SA970-GR-GR/BL
Q503, 504		Transistor, 2SA970-GR-GR/BL
Q505, 506		Transistor, 2SC1627A-Y
Q507, 508		Transistor, 2SC1626-Y
Q509, 510		Transistor, 2SA816-Y
Q511, 512		Transistor, 2SD525-O
Q513, 514		Transistor, 2SB595-O
Q515, 516		Transistor, 2SC1627A-Y
Q801		IC, TA7317P
D501, 502	22115560	Diode, KB362
D503, 504		Diode, M8513A-O
D801		Diode, 1S1942
\triangle D901	22115561	Diode, S4VB20-S
D902, 903		Diode, O2Z18A
D904		Diode, 1S1942
D905	22115515	Diode (LED), GD4-203-RED

Symbol No.	Part No.	Description
ELECTRICAL PARTS		
S301	22195018	Switch, Rotary (FUNCTION)
S401, 402	22195418	Switch, Push (TAPE/ LOUDNESS)
\triangle S501	22148650	Relay
S901	22195445	Switch, Push (POWER)
T901	22223656	Transformer, Power (TE)
\triangle T901	22223720	Transformer, Power (TU, AY)
J301	22163770	Jack, US-10P
J451, 501	22163699	Jack, Microphone/Headphone
J502	22162456	Terminal, 4P (Speaker)
\triangle F901	22144337	Fuse, 1A/250V
	22176286	Cord, Power (TE)
	22176536	Cord, Power (TU)
	22176588	Cord, Power (AY)
CAPACITORS		
J = $\pm 5\%$, K = $\pm 10\%$, P = -0 to $+100\%$, Z = -20 to $+80\%$		
C301, 302	22440331	Electrolytic, 10mfd, 16V
C303, 304	22343331	Ceramic, 330pF, 50V, K (Chip)
C305, 306	22483101	Electrolytic, 100mfd, 10V
C307, 308	22371183	Mylar, 0.018mfd, 50V, J
C309, 310	22349471	Ceramic, 470pF, 50V, K (Chip)
C311, 312	22371472	Mylar, 4700pF, 50V, J
C315, 316	22440334	Electrolytic, 1mfd, 50V
C401, 402	22343331	Ceramic, 330pF, 50V, K (Chip)
C403, 404	22371333	Mylar, 0.033mfd, 50V, J
C405, 406	22362101	Ceramic, 100pF, 50V, J (Chip)
C407, 408	22361330	Ceramic, 33pF, 50V, J (Chip)
C409, 410	22440333	Electrolytic, 4.7mfd, 35V
C411, 412	22371682	Mylar, 6800pF, 50V, J
C413, 414	22371393	Mylar, 0.039mfd, 50V, J
C415, 416	22371333	Mylar, 0.033mfd, 50V, J
C417, 418	22371224	Mylar, 0.22mfd, 50V, J
C419, 420	22440333	Electrolytic, 4.7mfd, 35V
C451	22440332	Electrolytic, 0.47mfd, 50V
C452	22343331	Ceramic, 330pF, 50V, K (Chip)
C453	22440331	Electrolytic, 10mfd, 16V
C454	22360392	Ceramic, 0.001mfd, 50V, K (Chip)
C455	22488108	Electrolytic, 0.1mfd, 50V
C501, 502	22440334	Electrolytic, 1mfd, 50V
C503, 504	22488470	Electrolytic, 47mfd, 50V

Symbol No.	Part No.	Description
C505, 506	22447221	Electrolytic, 220mfd, 35V
C509, 510	22483101	Electrolytic, 100mfd, 10V
C511, 512	22460149	Ceramic, 33pF, 50V, J (Chip)
C513, 514	22447221	Electrolytic, 220mfd, 35V
C517, 518	22360362	Ceramic, 470pF, 50V, K (Chip)
C801	22485220	Electrolytic, 22mfd, 16V
C802	22440332	Electrolytic, 0.47mfd, 50V
C803	22483101	Electrolytic, 100mfd, 10V
C901	22340150	Ceramic, 0.0047 mfd, AC 400V, M
C902, 903	22340032	Ceramic, 0.02mfd, 500V, Z
C904, 905	22440293	Electrolytic, 3300mfd, 35V
C906, 907	22486331	Electrolytic, 330mfd, 25V
C908	22340032	Ceramic, 0.02mfd, 500V, Z
C909	22440333	Electrolytic, 4.7mfd, 35V

RESISTORS

All resistors are 1/4W, ±5% carbon film unless otherwise noted.

R301, 302	22555473	47K ohm (Chip)
R303, 304	22555224	220K ohm (Chip)
R305, 306	22555331	330 ohm (Chip)
R307, 308	22555683	68K ohm (Chip)
R309, 310	22555221	220 ohm (Chip)
R311, 312	22555184	180K ohm (Chip)
R313, 314	22555153	15K ohm (Chip)
R315, 316	22555561	560 ohm (Chip)
R317, 318	22555104	100K ohm (Chip)
R319, 320	22555472	4.7K ohm (Chip)
R401, 402	22555472	4.7K ohm (Chip)
R403, 404	22555102	1K ohm (Chip)
R405, 406	22555822	8.2K ohm (Chip)
R407, 408	22555222	2.2K ohm (Chip)
R409, 410	22555562	5.6K ohm (Chip)
R411, 412	22555563	56K ohm (Chip)
R413, 414	22555272	2.7K ohm (Chip)
R415, 416	22555101	100 ohm (Chip)
R417, 418	22545123	12K ohm (Chip)
R419, 420	22555182	1.8K ohm (Chip)
R421, 422	22545473	47K ohm (Chip)
R423	22651515	Variable, 100K/250K ohm, VOLUME/BALANCE
R424, 425	22651503	Variable, 100K ohm, BASS/ TREBLE
R451	22555222	2.2K ohm (Chip)
R452	22555104	100K ohm (Chip)
R453	22555331	330 ohm (Chip)

Symbol No.	Part No.	Description
R454	22555683	68K ohm (Chip)
R455	22555820	82 ohm (Chip)
R456	22555224	220K ohm (Chip)
R457	22628405	Variable, 50K ohm, MIC LEVEL
R458, 459	22555563	56K ohm (Chip)
R501, 502	22555222	2.2K ohm (Chip)
R503, 504	22555473	47K ohm (Chip)
R505, 506	22555472	4.7K ohm (Chip)
R507, 508	22555221	220 ohm (Chip)
R509, 510	22555102	1K ohm (Chip)
R511, 512	22555272	2.7K ohm (Chip)
R513, 514	22555332	3.3K ohm (Chip)
R515, 516	22555473	47K ohm (Chip)
R517, 518	22555561	560 ohm (Chip)
R519, 520	22500122	100 ohm, Fusible
R521, 522	22570267	270 ohm, 1W, J, Metal Oxide Film
R523, 524	22570267	270 ohm, 1W, J, Metal Oxide Film
R525, 526	22500187	0.47 ohm, 5W, K, Metal Film
R527, 528	22500122	100 ohm, 1/4W, J, Fusible
R529, 530	22570250	10 ohm, 1W, J, Metal Oxide Film
R531, 532	22570266	220 ohm, 1W, J, Metal Oxide Film
R533, 534	22658518	Semi-fixed, 500 ohm
R535, 536	22555822	8.2K ohm
R537, 538	22555103	10K ohm
R539, 540		Termistor, D22A
R551, 552	22555473	47K ohm (Chip)
R801	22555124	120K ohm (Chip)
R802	22555822	8.2K ohm (Chip)
R803	22555822	8.2K ohm (Chip)
R804	22555333	33K ohm (Chip)
R805	22570266	220 ohm, 1W, J, Metal Oxide Film
R806	22555563	56K ohm (Chip)
R807	22555563	56K ohm (Chip)
R808	22555104	100K ohm (Chip)
R809, 810	22500117	220 ohm, 1/4W, J, Fusible
R901, 902	22500130	10 ohm, 1/4W, J, Fusible
R903	22555152	1.5K ohm (Chip)
R904	22555683	68K ohm (Chip)
R905		

ACCESSORY

22902389 Owner's Manual

TOSHIBA CORPORATION
2-1, GINZA 5-CHOME, CHUO-KU, TOKYO 104, JAPAN

PRINTED IN JAPAN 22955514 Jul. 1979

For Service Manuals Contact
MAURITRON TECHNICAL SERVICES
8 Cherry Tree Rd, Chinnor
Oxon OX9 4QY
Tel:- 01844-351694 Fax:- 01844-352554
Email: enquiries@maurtron.co.uk