

1 2 3 4 5 6 7 8 9 10 11 12 13 14 15 16 17 18 19 20 21 22 23 24 25 26 27 28 29 30

A  
B  
C  
D  
E  
F  
G  
H  
I  
J  
K  
L  
M  
N  
O  
P  
Q  
R  
S  
T  
U

**MAIN AMP BOARD (230/240V)**

ASSY 7117554400 : PA-200 (pcb 2292579700)  
ASSY 7117454400 : PA-400

**Type A**

PA-200 : SNo.ZA50100-ZB21049  
PA-400 : SNo.ZA50100-ZB21149

\* Refer to the "RE: TYPE A, TYPE B AND TYPE C OF MAIN AMP BOARD (230/240V)" (P. 13, 14) about compatibility of Type A, Type B and Type C.  
\* Type A, Type B, Type C の互換性については, "Main Amp Board (230/240V) の Type A, Type B, Type C について" (P. 13, 14) を参照して下さい。

**REPLACEMENT (補修用)**

**NOTE:** Replacement Main Amp Board of PA-200 and that of PA-400 have dedicated wiring Assy, respectively, and cannot be substituted for each other.  
注: PA-200 と PA-400 の補修用メイン・アンプ基板は、ワイヤリンクのため互換性はありません。

**NOTE:** Replacement Main Amp Board is 230/240V versions only. 230/240V version differs from 100/117V version only in fuse system Order proper fuses and fuse labels separately if necessary.  
(Refer to the table right)  
注: 補修用 Main Amp Board として 230/240V が共通使用されます。電圧区分による違いはヒューズ値、ヒューズ貼マークのみです。100/117V 用のヒューズ、ヒューズ貼マークが必要な場合は別途発注してください。(右表参照)

MAIN AMP BOARD (230/240V)  
ASSY 7117554400 : PA-200  
ASSY 7117454400 : PA-400

- ◆ Main Amp Board (230/240V) consists of the following 11PCBs.
- ◆ メイン・アンプ基板は、下記の11点から成ります
- Lch Power Amp Board (pcb 2292579700 1/10)
- Rch Power Amp Board (pcb 2292579700 2/10)
- Power Supply Board (pcb 2292579700 3/10)
- SP Jack Board (pcb 2292579700 4/10)
- SP Terminal Board (pcb 2292579700 5/10)
- VRGL Board (pcb 2292579700 6/10)
- Primary Board (pcb 2292579700 7/10)
- Spacer Board (pcb 2292579700 8/10)
- Spacer Board (pcb 2292579700 9/10)
- TR Board (Lch)
- TR Board (Rch)

**PA-200**

	Fuse	Parts No.	Fuse Label	Parts No.
100/117V	F1, F2	GGL-8A (12559421)	8.0A 250V	(41015174)
	F3, F4	T-GGS1A (12559335)	1.0A 250V	(41015163)
	F5, F6	TSC3A-N1 (12559402)	3.0A 125V	(41015119)
	F7	T-GGS1A (12559335)	1.0A 250V	(41015163)
220/240V	F1, F2	SF8A (12559608)	8.0A 60V	(41075199)
	F3, F4	CEE-400MAT (12559563)	T400mA 250V	(41015212)
	F5, F6	CEE-2.5AT (12559571)	T2.5A 250V	(41015220)
	F7	CEE-250MAT (12559561)	T250mA 250V	(41015210)

**PA-400**

	Fuse	Parts No.	Fuse Label	Parts No.
100/117V	F1, F2	GGL-10A (12559384)	10.0A 250V	(41015175)
	F3, F4	T-GGS1A (12559335)	1.0A 250V	(41015163)
	F5, F6	TSC3A-N1 (12559402)	3.0A 125V	(41015119)
	F7	T-GGS1A (12559335)	1.0A 250V	(41015163)
220/240V	F1, F2	SF10A (12559607)	10.0A 60V	(41075200)
	F3, F4	CEE-400MAT (12559563)	T400mA 250V	(41015212)
	F5, F6	CEE-2.5AT (12559571)	T2.5A 250V	(41015220)
	F7	CEE-250MAT (12559561)	T250mA 250V	(41015210)

**Spacer Board**

(pcb 2292579700 8/10)

**SP Jack Board**

(pcb 2292579700 4/10)

**TR Board (Lch)**

**Spacer Board**

(pcb 2292579700 9/10)

**VRGL Board**

(pcb 2292579700 6/10)

**Primary Board**

(pcb 2292579700 7/10)

**SP Terminal Board**

(pcb 2292579700 5/10)

**Power Supply Board**

(pcb 2292579700 3/10)

**Lch Power Amp Board**  
(pcb 2292579700 1/10)

**TR Board (Rch)**

**Rch Power Amp Board**  
(pcb 2292579700 2/10)

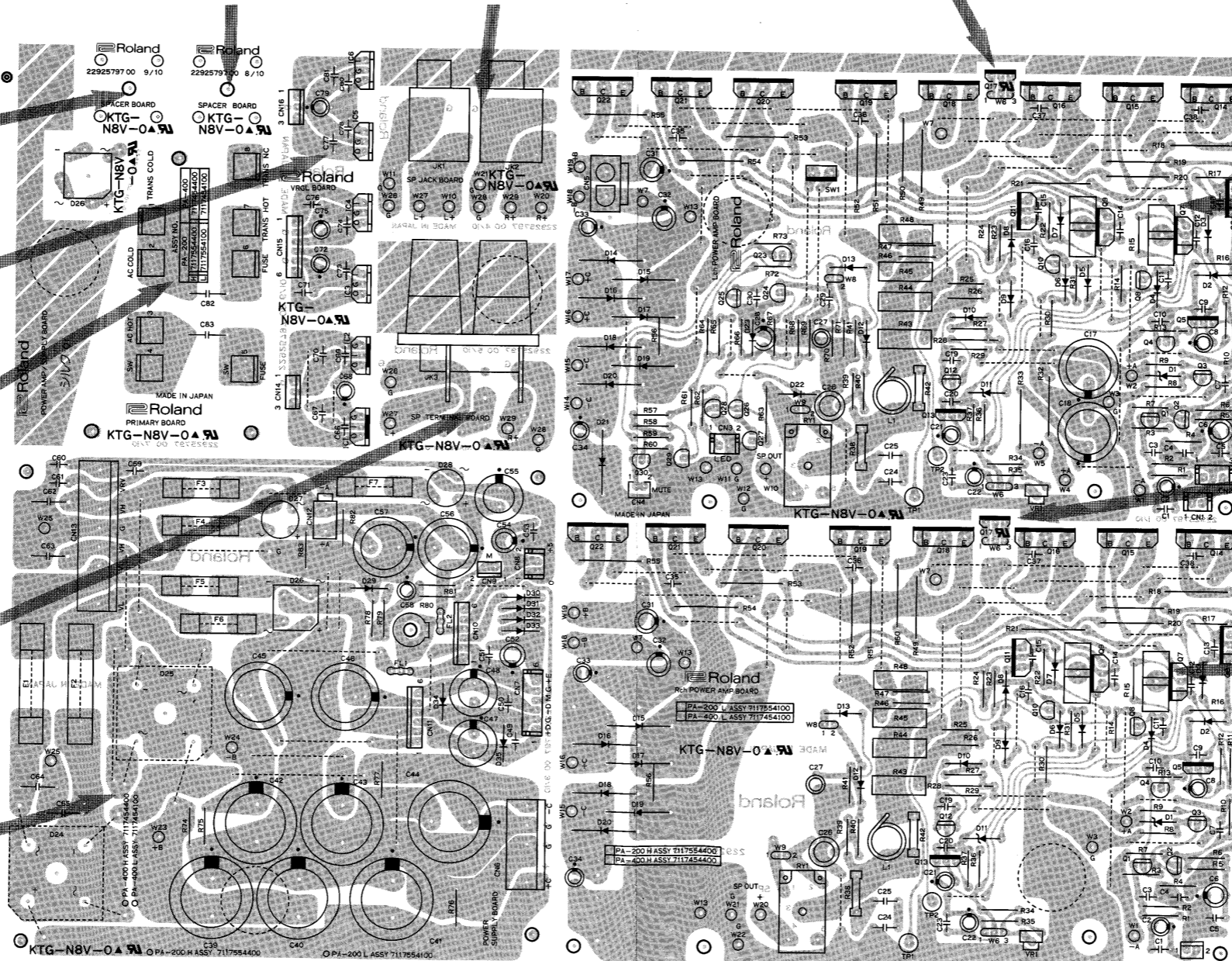

View from component side

CIRCUIT DIAGRAM (Power Amp Board: PA-200)  
Type A: SNo.ZA50100-ZB21049

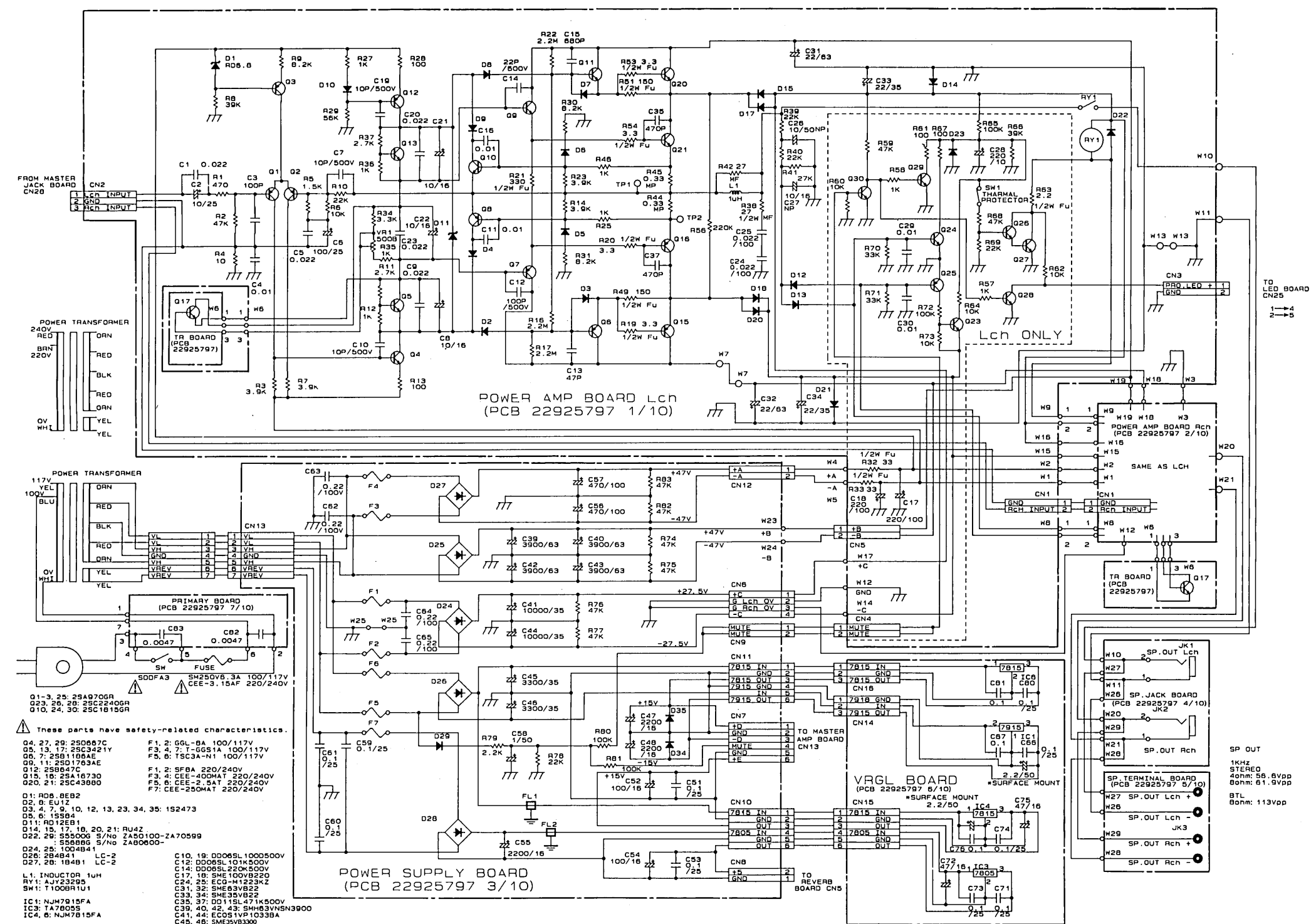

- △ These parts have safety-related characteristics.
- C1: 0.002
  - C2: 0.001
  - C3: 0.001
  - C4: 0.001
  - C5: 0.001
  - C6: 0.001
  - C7: 0.001
  - C8: 0.001
  - C9: 0.001
  - C10: 0.001
  - C11: 0.001
  - C12: 0.001
  - C13: 0.001
  - C14: 0.001
  - C15: 0.001
  - C16: 0.001
  - C17: 0.001
  - C18: 0.001
  - C19: 0.001
  - C20: 0.001
  - C21: 0.001
  - C22: 0.001
  - C23: 0.001
  - C24: 0.001
  - C25: 0.001
  - C26: 0.001
  - C27: 0.001
  - C28: 0.001
  - C29: 0.001
  - C30: 0.001
  - C31: 0.001
  - C32: 0.001
  - C33: 0.001
  - C34: 0.001
  - C35: 0.001
  - C36: 0.001
  - C37: 0.001
  - C38: 0.001
  - C39: 0.001
  - C40: 0.001
  - C41: 0.001
  - C42: 0.001
  - C43: 0.001
  - C44: 0.001
  - C45: 0.001
  - C46: 0.001
  - C47: 0.001
  - C48: 0.001
  - C49: 0.001
  - C50: 0.001
  - C51: 0.001
  - C52: 0.001
  - C53: 0.001
  - C54: 0.001
  - C55: 0.001
  - C56: 0.001
  - C57: 0.001
  - C58: 0.001
  - C59: 0.001
  - C60: 0.001
  - C61: 0.001
  - C62: 0.001
  - C63: 0.001
  - C64: 0.001
  - C65: 0.001
  - C66: 0.001
  - C67: 0.001
  - C68: 0.001
  - C69: 0.001
  - C70: 0.001
  - C71: 0.001
  - C72: 0.001
  - C73: 0.001
  - C74: 0.001
  - C75: 0.001
  - C76: 0.001
  - C77: 0.001
  - C78: 0.001
  - C79: 0.001
  - C80: 0.001
  - C81: 0.001
  - C82: 0.001
  - C83: 0.001
  - C84: 0.001
  - C85: 0.001
  - C86: 0.001
  - C87: 0.001
  - C88: 0.001
  - C89: 0.001
  - C90: 0.001
  - C91: 0.001
  - C92: 0.001
  - C93: 0.001
  - C94: 0.001
  - C95: 0.001
  - C96: 0.001
  - C97: 0.001
  - C98: 0.001
  - C99: 0.001
  - C100: 0.001

△ Signal levels (dBm, Vpp) in circuit diagram are taken under conditions.  
 △ 回路図中の信号レベル (dBm, Vpp) は上記の条件下で測定された値です。

SETTING/設定

CHANNEL SECTION	MASTER SECTION
SENS : 40dBm	RETURN : 10 (MAX)
PAD : OFF	RTN2 : 10 (MAX)
AUX SELECTOR : Select it if necessary	SEND : OFF
EQ (HIGH) : center	REV : 8
(MID) : center	EFF : 8
(LOW) : center	MON : 8
REVEFF : center	PHONES : 10
When REV circuit is checked	RTN2-LEVEL : Select this button according to INPUT LEVEL
When EFF circuit is checked	MON : 10 (MAX)
MON : 10 (MAX)	GEO : OFF
PAN : center	MASTER Faders : 8
CH Faders : 10 (MAX)	SUBOUT Faders : 8

CIRCUIT DIAGRAM (Power Amp Board: PA-400)  
Type A: SNo.ZA50100-ZB21149

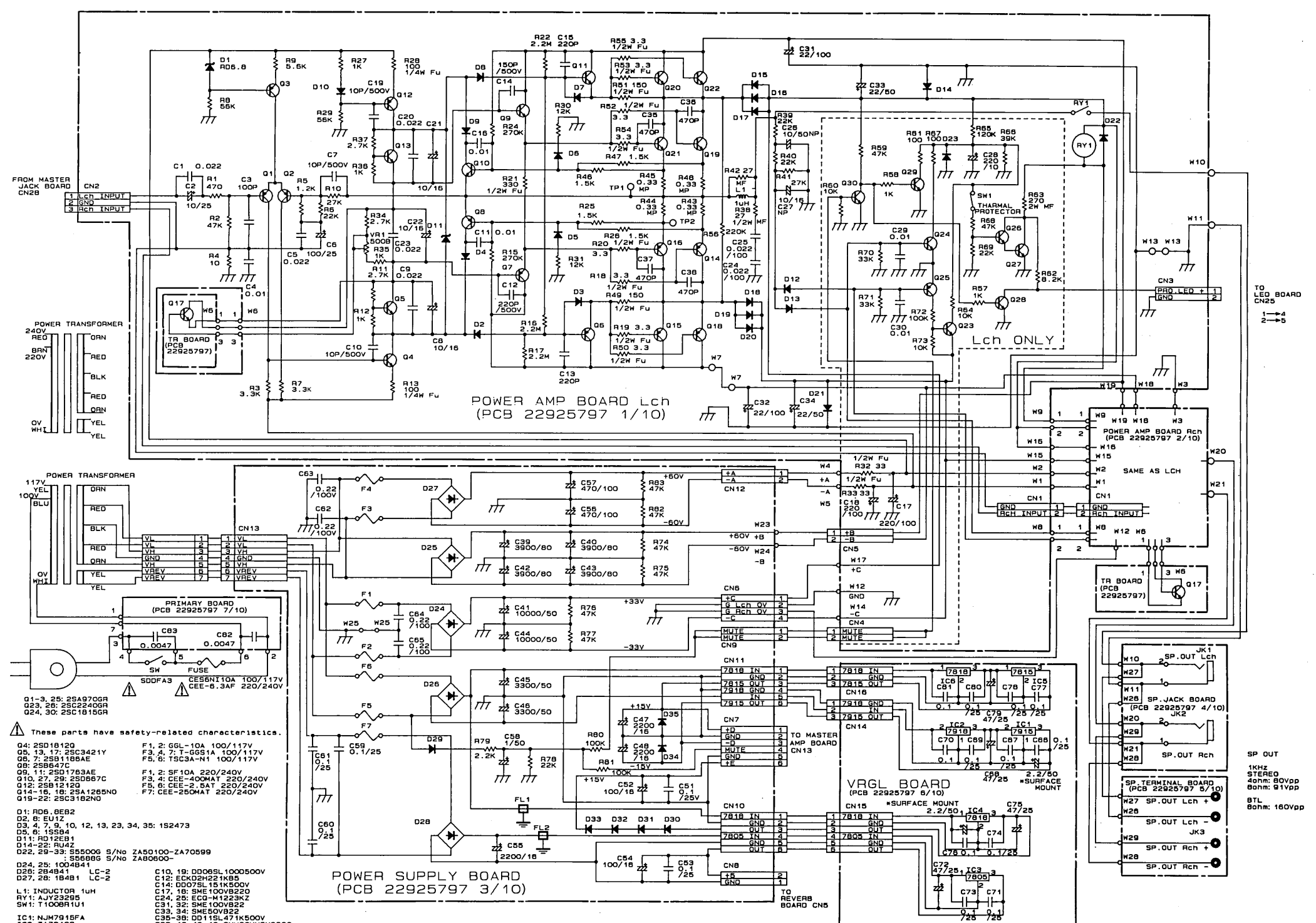

- △ These parts have safety-related characteristics.
- C1: 0.002
  - C2: 0.001
  - C3: 0.001
  - C4: 0.001
  - C5: 0.001
  - C6: 0.001
  - C7: 0.001
  - C8: 0.001
  - C9: 0.001
  - C10: 0.001
  - C11: 0.001
  - C12: 0.001
  - C13: 0.001
  - C14: 0.001
  - C15: 0.001
  - C16: 0.001
  - C17: 0.001
  - C18: 0.001
  - C19: 0.001
  - C20: 0.001
  - C21: 0.001
  - C22: 0.001
  - C23: 0.001
  - C24: 0.001
  - C25: 0.001
  - C26: 0.001
  - C27: 0.001
  - C28: 0.001
  - C29: 0.001
  - C30: 0.001
  - C31: 0.001
  - C32: 0.001
  - C33: 0.001
  - C34: 0.001
  - C35: 0.001
  - C36: 0.001
  - C37: 0.001
  - C38: 0.001
  - C39: 0.001
  - C40: 0.001
  - C41: 0.001
  - C42: 0.001
  - C43: 0.001
  - C44: 0.001
  - C45: 0.001
  - C46: 0.001
  - C47: 0.001
  - C48: 0.001
  - C49: 0.001
  - C50: 0.001
  - C51: 0.001
  - C52: 0.001
  - C53: 0.001
  - C54: 0.001
  - C55: 0.001
  - C56: 0.001
  - C57: 0.001
  - C58: 0.001
  - C59: 0.001
  - C60: 0.001
  - C61: 0.001
  - C62: 0.001
  - C63: 0.001
  - C64: 0.001
  - C65: 0.001
  - C66: 0.001
  - C67: 0.001
  - C68: 0.001
  - C69: 0.001
  - C70: 0.001
  - C71: 0.001
  - C72: 0.001
  - C73: 0.001
  - C74: 0.001
  - C75: 0.001
  - C76: 0.001
  - C77: 0.001
  - C78: 0.001
  - C79: 0.001
  - C80: 0.001
  - C81: 0.001
  - C82: 0.001
  - C83: 0.001
  - C84: 0.001
  - C85: 0.001
  - C86: 0.001
  - C87: 0.001
  - C88: 0.001
  - C89: 0.001
  - C90: 0.001
  - C91: 0.001
  - C92: 0.001
  - C93: 0.001
  - C94: 0.001
  - C95: 0.001
  - C96: 0.001
  - C97: 0.001
  - C98: 0.001
  - C99: 0.001
  - C100: 0.001

△ Signal levels (dBm, Vpp) in circuit diagram are taken under conditions.  
 △ 回路図中の信号レベル (dBm, Vpp) は上記の条件下で測定された値です。

SETTING/設定

CHANNEL SECTION	MASTER SECTION
SENS : 40dBm	RETURN : 10 (MAX)
PAD : OFF	RTN2 : 10 (MAX)
AUX SELECTOR : Select it if necessary	SEND : OFF
EQ (HIGH) : center	REV : 8
(MID) : center	EFF : 8
(LOW) : center	MON : 8
REVEFF : center	PHONES : 10
When REV circuit is checked	RTN2-LEVEL : Select this button according to INPUT LEVEL
When EFF circuit is checked	MON : 10 (MAX)
MON : 10 (MAX)	GEO : OFF
PAN : center	MASTER Faders : 8
CH Faders : 10 (MAX)	SUBOUT Faders : 8





1 2 3 4 5 6 7 8 9 10 11 12 13 14 15 16 17 18 19 20 21 22 23 24 25 26 27 28 29 30

A  
B  
C  
D  
E  
F  
G  
H  
I  
J  
K  
L  
M  
N  
O  
P  
Q  
R  
S  
T  
U

### MAIN AMP BOARD (230/240V)

ASSY 7117554401 : PA-200 (pcb 2292579701)  
ASSY 7117454401 : PA-400

### Type B

PA-200 : SNo.ZB31050—ZC41899  
PA-400 : SNo.ZB31150—ZC52849

\* Refer to the "RE: TYPE A, TYPE B AND TYPE C OF MAIN AMP BOARD (230/240V)" (P. 13, 14) about compatibility of Type A, Type B and Type C.  
\* Type A, Type B, Type C の互換性については, "Main Amp Board (230/240V) の Type A, Type B, Type C について" (P. 13, 14) を参照して下さい。

#### REPLACEMENT (補修用)

MAIN AMP BOARD (230/240V)  
ASSY 7117554401 : PA-200  
ASSY 7117454401 : PA-400

◆ Main Amp Board (230/240V) consists of the following 11PCBs.

- ◆ メイン・アンプ基板は, 下記の11点から成ります
- Lch Power Amp Board (pcb 2292579701 1/10)
- Rch Power Amp Board (pcb 2292579701 2/10)
- Power Supply Board (pcb 2292579701 3/10)
- SP Jack Board (pcb 2292579701 4/10)
- SP Terminal Board (pcb 2292579701 5/10)
- VRGL Board (pcb 2292579701 6/10)
- Primary Board (pcb 2292579701 7/10)
- Spacer Board (pcb 2292579701 8/10)
- Spacer Board (pcb 2292579701 9/10)
- TR Board (Lch) (pcb 2292579701 10/10)
- TR Board (Rch) (pcb 2292579701 11/10)

NOTE: Replacement Main Amp Board of PA-200 and that of PA-400 have dedicated wiring Assy, respectively, and cannot be substituted for each other.

注: PA-200 と PA-400 の補修用メイン・アンプ基板は, ワイヤリンクのため互換性はありません。

NOTE: Replacement Main Amp Board is 230/240V versions only. 230/240V version differs from 100/117V version only in fuse system Order proper fuses and fuse labels separately if necessary.

(Refer to the table right)

注: 補修用 Main Amp Board として230/240V が共通使用されます。電圧区分による違いはヒューズ値, ヒューズ貼マークのみです。

100/117V 用のヒューズ, ヒューズ貼マークが必要な場合は別途発注してください。(右表参照)

#### PA-200

	Fuse	Parts No.	Fuse Label	Parts No.
100/117V	F1, F2	GGL-8A (12559421)	8.0A 250V	(41015174)
	F3, F4	T-GGS1A (12559335)	1.0A 250V	(41015163)
	F5, F6	TSC3A-N1 (12559402)	3.0A 125V	(41015119)
	F7	T-GGS1A (12559335)	1.0A 250V	(41015163)
220/240V	F1, F2	SF8A (12559608)	8.0A 60V	(41075199)
	F3, F4	CEE-400MAT (12559563)	T400mA 250V	(41015212)
	F5, F6	CEE-2.5AT (12559571)	T2.5A 250V	(41015220)
	F7	CEE-250MAT (12559561)	T250mA 250V	(41015210)

#### PA-400

	Fuse	Parts No.	Fuse Label	Parts No.
100/117V	F1, F2	GGL-10A (12559384)	10.0A 250V	(41015175)
	F3, F4	T-GGS1A (12559335)	1.0A 250V	(41015163)
	F5, F6	TSC3A-N1 (12559402)	3.0A 125V	(41015119)
	F7	T-GGS1A (12559335)	1.0A 250V	(41015163)
220/240V	F1, F2	SF10A (12559607)	10.0A 60V	(41075200)
	F3, F4	CEE-400MAT (12559563)	T400mA 250V	(41015212)
	F5, F6	CEE-2.5AT (12559571)	T2.5A 250V	(41015220)
	F7	CEE-250MAT (12559561)	T250mA 250V	(41015210)

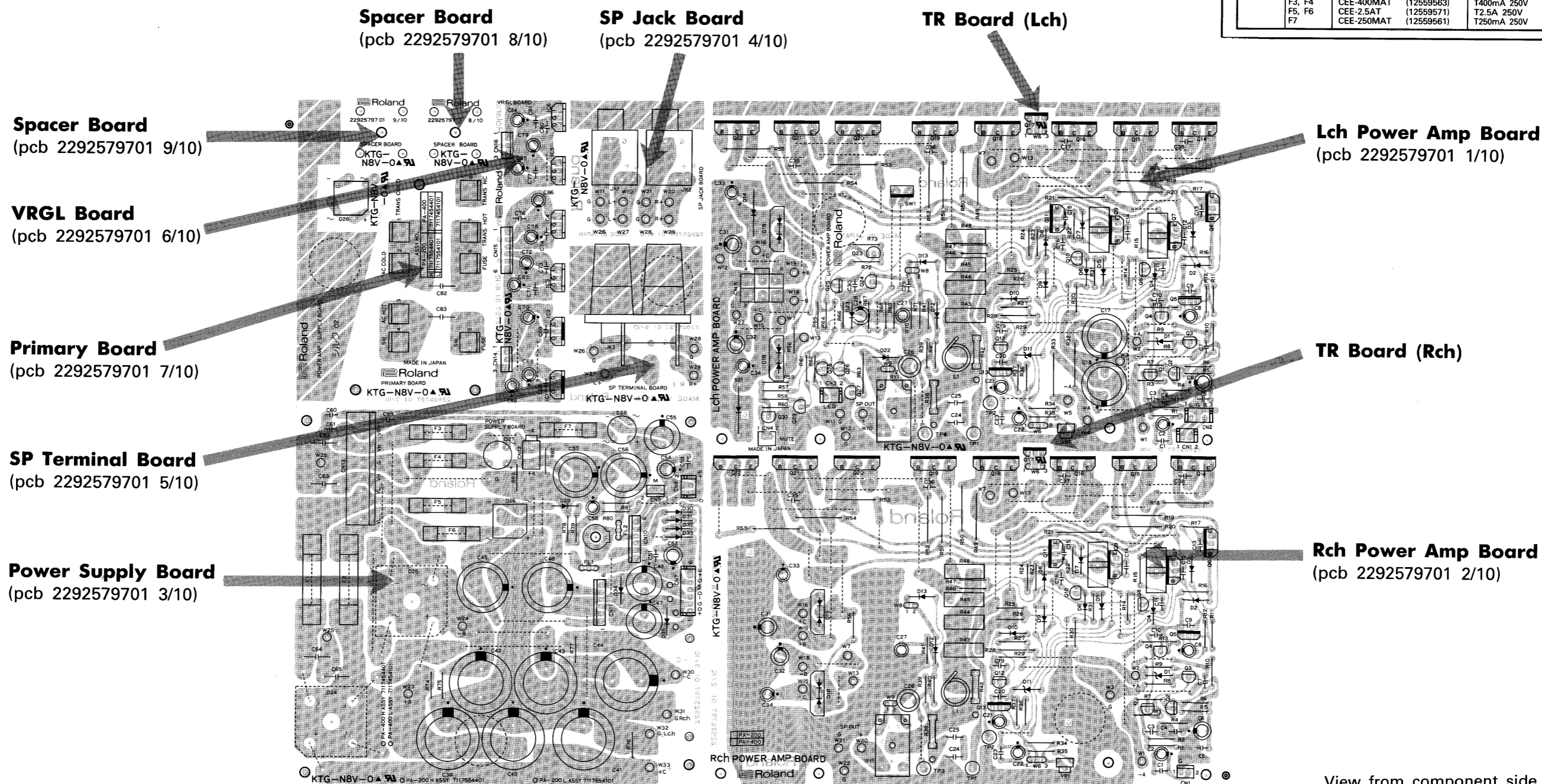

View from component side



1 2 3 4 5 6 7 8 9 10 11 12 13 14 15 16 17 18 19 20 21 22 23 24 25 26 27 28 29 30

A  
B  
C  
D  
E  
F  
G  
H  
I  
J  
K  
L  
M  
N  
O  
P  
Q  
R  
S  
T  
U

**MAIN AMP BOARD (230/240V) Type C**

ASSY 7117554402 : PA-200 (pcb 2292579702) PA-200 : SNo.ZD11900-up/以降  
 ASSY 7117454402 : PA-400 PA-400 : SNo.ZC62850-up/以降

\* Refer to the "RE: TYPE A, TYPE B AND TYPE C OF MAIN AMP BOARD (230/240V)" (P. 13, 14) about compatibility of Type A, Type B and Type C.  
 \* Type A, Type B, Type C の互換性については, "Main Amp Board (230/240V) の Type A, Type B, Type C について" (P. 13, 14) を参照して下さい。

**REPLACEMENT (補修用)**

MAIN AMP BOARD (230/240V)  
 ASSY 7117554402 : PA-200  
 ASSY 7117454402 : PA-400

◆ Main Amp Board (230/240V) consists of the following 11PCBs.

- ◆ メイン・アンプ基板は, 下記の11点から成ります
- Lch Power Amp Board (pcb 2292579702 1/10)
- Rch Power Amp Board (pcb 2292579702 2/10)
- Power Supply Board (pcb 2292579702 3/10)
- SP Jack Board (pcb 2292579702 4/10)
- SP Terminal Board (pcb 2292579702 5/10)
- VRGL Board (pcb 2292579702 6/10)
- Primary Board (pcb 2292579702 7/10)
- Spacer Board (pcb 2292579702 8/10)
- Spacer Board (pcb 2292579702 9/10)
- TR Board (Lch)
- TR Board (Rch)

NOTE: Replacement Main Amp Board of PA-200 and that of PA-400 have dedicated wiring Assy, respectively, and cannot be substituted for each other.

注: PA-200 と PA-400 の補修用メイン・アンプ基板は, ワイヤリンクのため互換性がありません。

NOTE: Replacement Main Amp Board is 230/240V versions only. 230/240V version differs from 100/117V version only in fuse system. Order proper fuses and fuse labels separately if necessary.

(Refer to the table right)

注: 補修用 Main Amp Board として230/240V が共通使用されます。電圧区分による違いはヒューズ値, ヒューズ貼マークのみです。100/117V 用のヒューズ, ヒューズ貼マークが必要な場合は別途発注してください。(右表参照)

**PA-200**

	Fuse	Parts No.	Fuse Label	Parts No.
100/117V	F1, F2 F3, F4 F5, F6 F7	GGL-8A (12559421) T-GGS1A (12559335) TSC3A-N1 (12559402) T-GGS1A (12559335)	8.0A 250V 1.0A 250V 3.0A 125V 1.0A 250V	(41015174) (41015163) (41015119) (41015163)
220/240V	F1, F2 F3, F4 F5, F6 F7	SF8A (12559608) CEE-400MAT (12559563) CEE-2.5AT (12559571) CEE-250MAT (12559561)	8.0A 60V T400mA 250V T2.5A 250V T250mA 250V	(41075199) (41015212) (41015220) (41015210)

**PA-400**

	Fuse	Parts No.	Fuse Label	Parts No.
100/117V	F1, F2 F3, F4 F5, F6 F7	GGL-10A (12559384) T-GGS1A (12559335) TSC3A-N1 (12559402) T-GGS1A (12559335)	10.0A 250V 1.0A 250V 3.0A 125V 1.0A 250V	(41015175) (41015163) (41015119) (41015163)
220/240V	F1, F2 F3, F4 F5, F6 F7	SF10A (12559607) CEE-400MAT (12559563) CEE-2.5AT (12559571) CEE-250MAT (12559561)	10.0A 60V T400mA 250V T2.5A 250V T250mA 250V	(41075200) (41015212) (41015220) (41015210)

**Spacer Board**

(pcb 2292579702 8/10)

**SP Jack Board**

(pcb 2292579702 4/10)

**TR Board (Lch)**

**Spacer Board**

(pcb 2292579702 9/10)

**VRGL Board**

(pcb 2292579702 6/10)

**Primary Board**

(pcb 2292579702 7/10)

**SP Terminal Board**

(pcb 2292579702 5/10)

**Power Supply Board**

(pcb 2292579702 3/10)

**Lch Power Amp Board**

(pcb 2292579702 1/10)

**TR Board (Rch)**

**Rch Power Amp Board**

(pcb 2292579702 2/10)

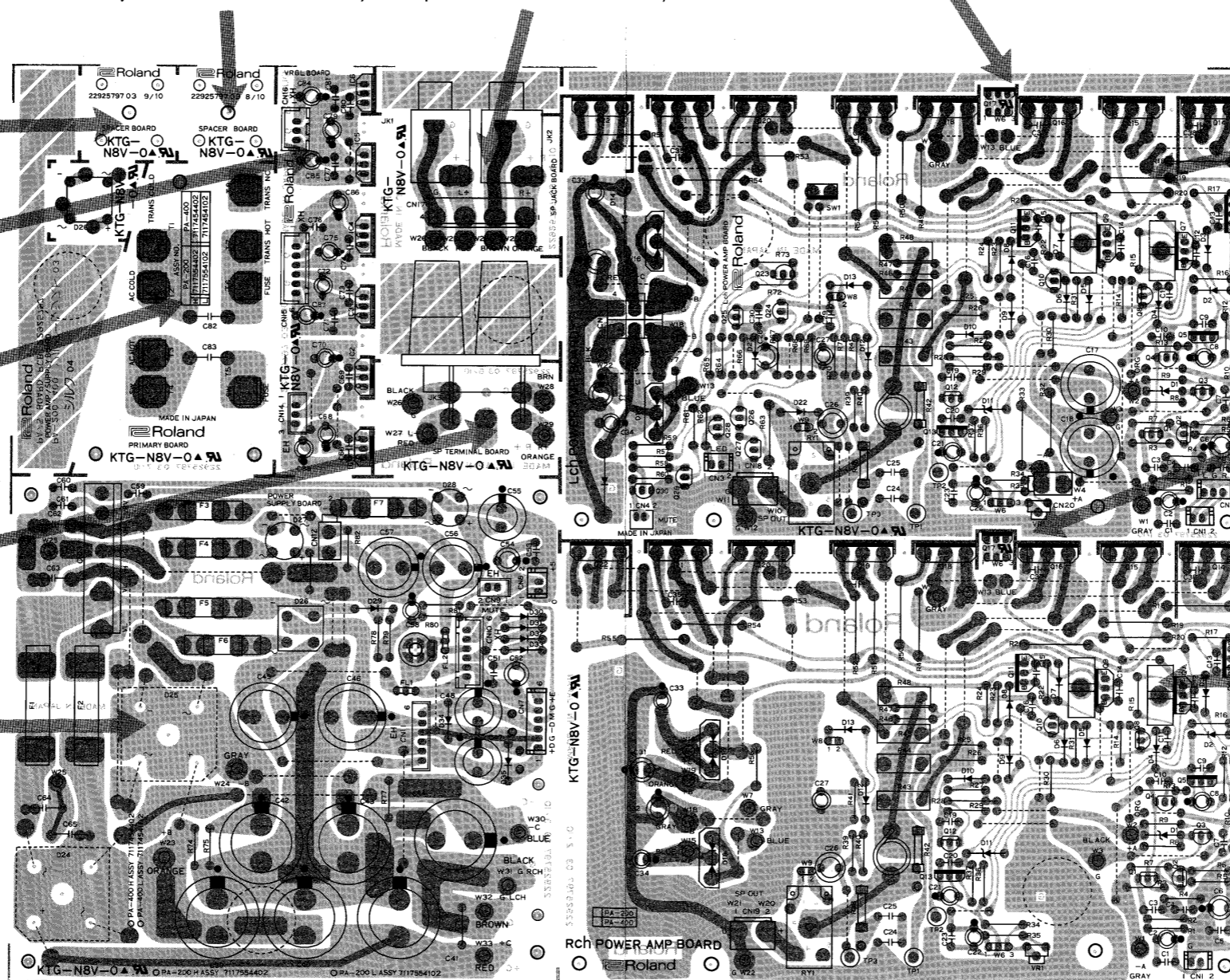

View from component side

1 2 3 4 5 6 7 8 9 10 11 12 13 14 15 16 17 18 19 20 21 22 23 24 25 26 27 28 29 30

**A REVERB BOARD**  
**B ASSY 7117441000**  
**C (pcb 2292579400)**

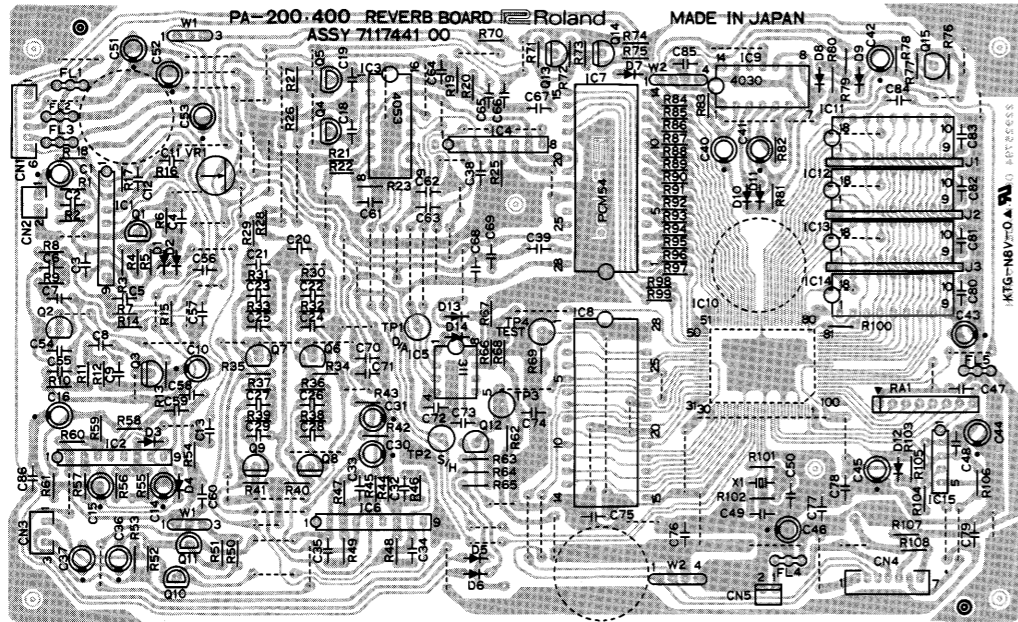

View from component side

**CIRCUIT DIAGRAM (Reverb Board)**

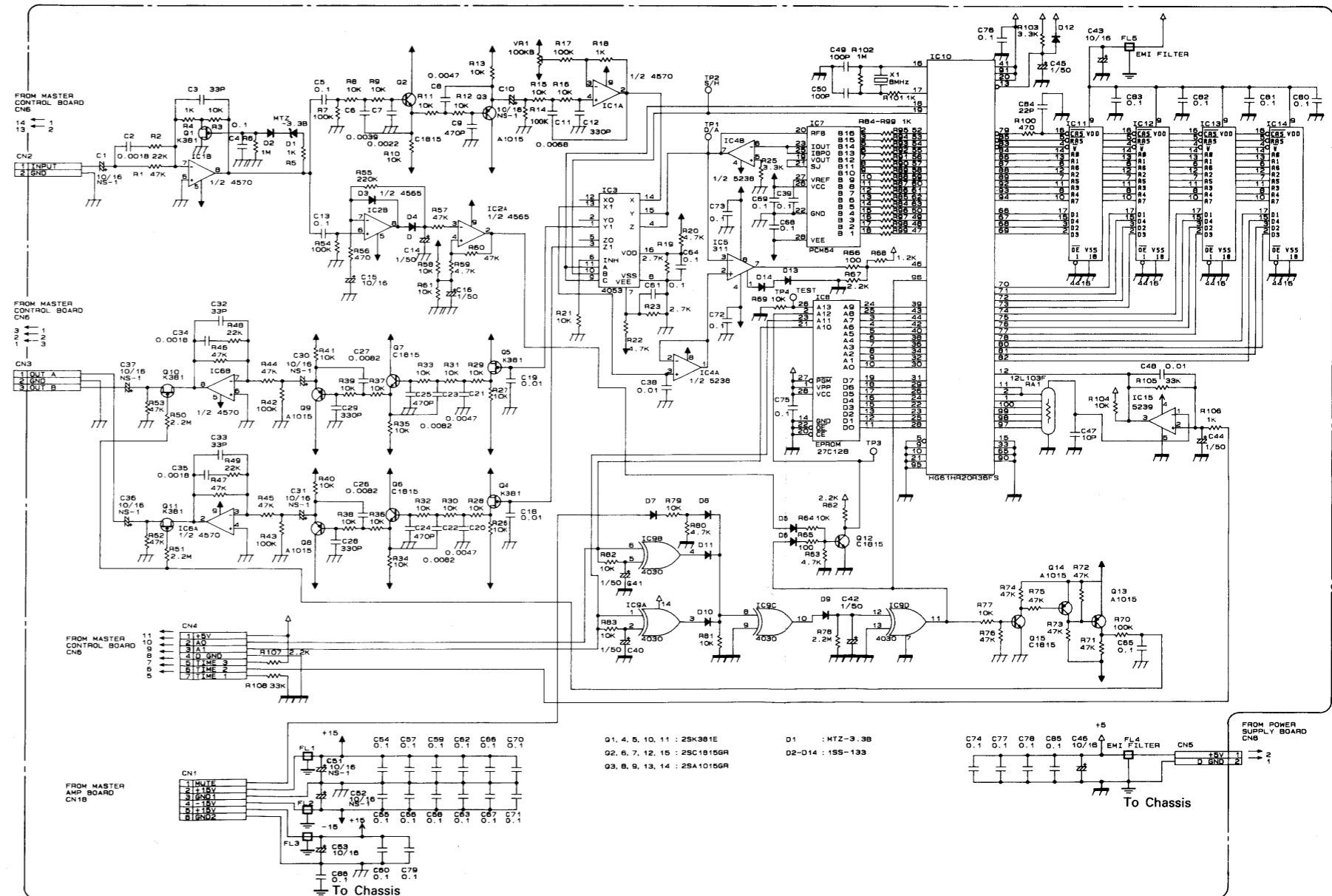

A  
B  
C  
D  
E  
F  
G  
H  
I  
J  
K  
L  
M  
N  
O  
P  
Q  
R  
S  
T  
U

**CORRELATION TABLE (PCBs and Parts)/基板と部品の相関表**

Serial Number/製番																																											
PA-200	ZA50100 - ZB21049	ZB31050 - ZC41899	ZD11900 - up/以降																																								
PA-400	ZA50100 - ZB21149	ZB31150 - ZC52849	ZC62850 - up/以降																																								
<b>Main Amp Board</b> (incompatible) (互換無し)	<p>—Type A— PA-200: ASSY 7117554400 (pcb 2292579700) PA-400: ASSY 7117454400 (pcb 2292579700)</p> <p>* Jumper (Surface Mount/裏付け)</p> <p>◆Refer to "RE:TYPE A, TYPE B AND TYPE C OF MAIN AMP BOARD (230/240V)" (P. 13, 14) for details. ◆詳細は, "Main Amp Board(230/240V)の Type A, Type B, Type C について" (P. 13, 14) を参照して下さい。</p>	<p>—Type B— PA-200: ASSY 7117554401 (pcb 2292579701) PA-400: ASSY 7117454401 (pcb 2292579701)</p> <p>* Change parts Wiring, Connector (CN5), D15, D18 (FMU-32S: PNo. 15039134) * Deleted parts Connector (CN6) * relayont of pattern.</p> <p>* 部品変更 ワイヤリング, コネクター (CN5) D15, D18 (FMU-32S: PNo. 15039134) * 部品削除 コネクター (CN6) * パターン変更</p>	<p>—Type C— PA-200: ASSY 7117554402 (pcb 2292579702) PA-400: ASSY 7117454402 (pcb 2292579702)</p> <p>* Change of Connectors (from direct installation type to removable type.) CN1, 9, 10, 11, 14, 15, 16 * Addition of Connectors CN17, 18, 19, 20 NOTE: This corresponds to the WNo. of the Type B as indicated below.</p> <table border="1" style="margin-left: auto; margin-right: auto;"> <tr> <td colspan="2">CN17</td> <td colspan="2">CN18</td> <td colspan="2">CN19</td> <td colspan="2">CN20</td> </tr> <tr> <td>1</td><td>W29</td> <td>1</td><td>W11</td> <td>1</td><td>W21</td> <td>1</td><td>W4</td> </tr> <tr> <td>2</td><td>W28</td> <td>2</td><td>W12</td> <td>2</td><td>W20</td> <td>2</td><td>W5</td> </tr> <tr> <td>3</td><td>W27</td> <td></td><td></td> <td></td><td></td> <td></td><td></td> </tr> <tr> <td>4</td><td>W26</td> <td></td><td></td> <td></td><td></td> <td></td><td></td> </tr> </table> <p>* コネクタ変更 (直付→脱着) CN1, 9, 10, 11, 14, 15, 16 * コネクタ追加 CN17, 18, 19, 20 注: これは Type B の WNo. と下記のように対応しています。</p> <p>◆The circuit diagram remains unchanged. ◆回路図上の変更はなし。</p>	CN17		CN18		CN19		CN20		1	W29	1	W11	1	W21	1	W4	2	W28	2	W12	2	W20	2	W5	3	W27							4	W26						
CN17		CN18		CN19		CN20																																					
1	W29	1	W11	1	W21	1	W4																																				
2	W28	2	W12	2	W20	2	W5																																				
3	W27																																										
4	W26																																										
<b>Channel Board</b> (compatible) (互換有り)	<p>PA-200: ASSY 7117543000 (pcb 2292579600) PA-400: ASSY 7117443000 (pcb 2292579600)</p> <p>* R1, R30, C37, Jumper (Surface Mount/裏付け)</p>	<p>PA-200: ASSY 7117543001 (pcb 2292579601) PA-400: ASSY 7117443001 (pcb 2292579601)</p> <p>* Relayout of pattern. * パターン変更</p>	<p>PA-200: ASSY 7117543002 (pcb 2292579602) PA-400: ASSY 7117443002 (pcb 2292579602)</p> <p>* Change of Connectors (from direct installation type to removable type.) Stereo Input Jack Board CN1, 2, 3 Channel Control Board A CN3 Channel Control Board B CN3 Insert Jack Board CN5 * Added Parts PA-200 (VR MASK B 22245576 VR MASK C 22245577) PA-400 (VR MASK B 22245576 VR MASK C 22245577 VR MASK D 22245578) * Deletion of parts PA-200 CH FADER MASK 22245550 PA-400 CH FADER MASK 22245553 NOTE: Note that the following parts must be installed to the panel. PA-200 FADER MASK 22245214 PA-400 FADER MASK 22245215</p> <p>* コネクタ変更 (直付→脱着) Stereo Input Jack Board CN1, 2, 3 Channel Control Board A CN3 Channel Control Board B CN3 Insert Jack Board CN5 * 部品追加 PA-200 (VR MASK B 22245576 VR MASK C 22245577) PA-400 (VR MASK B 22245576 VR MASK C 22245577 VR MASK D 22245578) * 部品削除 PA-200 CH FADER MASK 22245550 PA-400 CH FADER MASK 22245553 注: ただし PANEL に下記の部品の取付が必要です。 PA-200 FADER MASK 22245214 PA-400 FADER MASK 22245215</p>																																								
<b>Master Board</b> (compatible) (互換有り)	<p>PA-200: ASSY 711754300 (pcb 2292579600) PA-400: ASSY 711744300 (pcb 2292579600)</p>	<p>PA-200: ASSY 7117542001 (pcb 2292579501) PA-400: ASSY 7117442001 (pcb 2292579501)</p> <p>* Added parts C151-154 * Relayout of pattern.</p> <p>* 追加部品 C151-154 * パターン変更</p>	<p>PA-200: ASSY 7117542002 (pcb 2292579502) PA-400: ASSY 7117442002 (pcb 2292579502)</p> <p>* Change of Connectors (from direct installation type to removable type.) CN1, 2, 3, 4, 5, 6, 7, 8, 9, 10, 12, 13, 14, 15, 16, 18, 20, 21, 24, 25, 28, 32 * Added Parts PA-200/400 Common VR MASK A 22245563 To prevent the VR from becoming loose. * Deletion of parts PA-200/400 Common MASTER FADER MASK 22245549 NOTE: Note that the following parts must be installed to the panel. PA-200 FADER MASK 22245214 PA-400 FADER MASK 22245215</p> <p>* コネクタ変更 (直付→脱着) CN1, 2, 3, 4, 5, 6, 7, 8, 9, 10, 12, 13, 14, 15, 16, 18, 20, 21, 24, 25, 28, 32 * 部品追加 PA-200/400 共通 VR MASK A 22245563 VR のグラツキ防止の為 * 部品削除 PA-200/400 共通 MASTER FADER MASK 22245549 注: ただし PANEL に下記の部品の取付が必要です。 PA-200 FADER MASK 22245214 PA-400 FADER MASK 22245215</p>																																								
<b>Reverb Board</b>	<p>PA-200/PA-400 (Common/共通) ASSY 7117441000 (pcb 2292579400)</p>																																										

Page	WRONG 誤	CORRECT 正
12	<p data-bbox="336 331 539 360">&lt;Parts List&gt;</p> <p data-bbox="352 427 659 456">* FUSE, FUSE HOLDER</p> <p data-bbox="384 495 778 555"> <u>12559422</u> CES6N1 10A            110/117V         </p>	<p data-bbox="943 495 1337 555"> <u>12559467</u> CES6N1 10A            110/117V         </p>



(Small errors are ignored. 重要でないエラーは無視します。)

Page	WRONG 誤	CORRECT 正
------	---------	-----------

\* Please amend all existing Service Notes as follows.  
\* 該当サービスノートを下記のように修正して下さい。

< BLOCK DIAGRAM >

Third Edition p.18  
Second Edition p.16

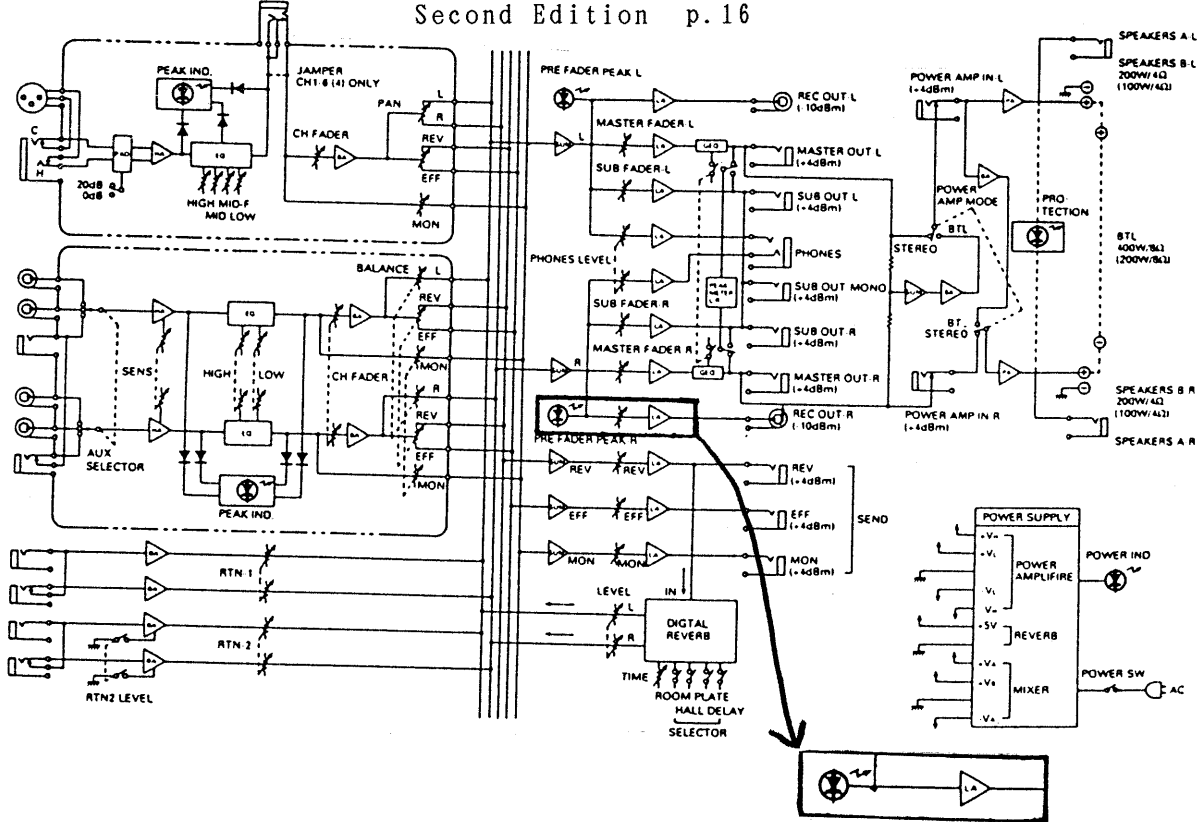

< CIRCUIT DIAGRAM >

Third Edition p.21  
Second Edition p.19

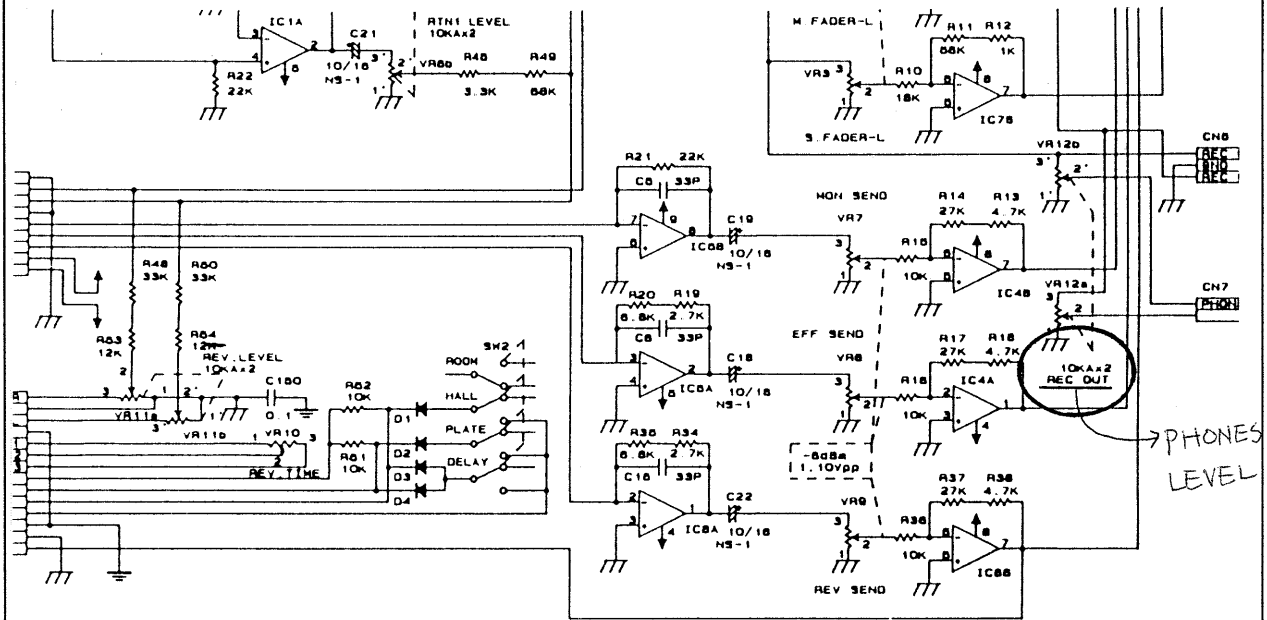

MASTER CONTROL BOARD  
(PCB 22925795 1/12)