

Service Manual

EM-1

CONTENTS

- 1) Structural Diagram - - - - -
- 2) Block Diagram - - - - -
- 3) Circuit Diagram - - - - -
- 4) Diagnostics - - - - -
- 5) Parts List - - - - -

Revision: 1.00
Issued date: June 27th, 2001
Issued by: KORG INC.

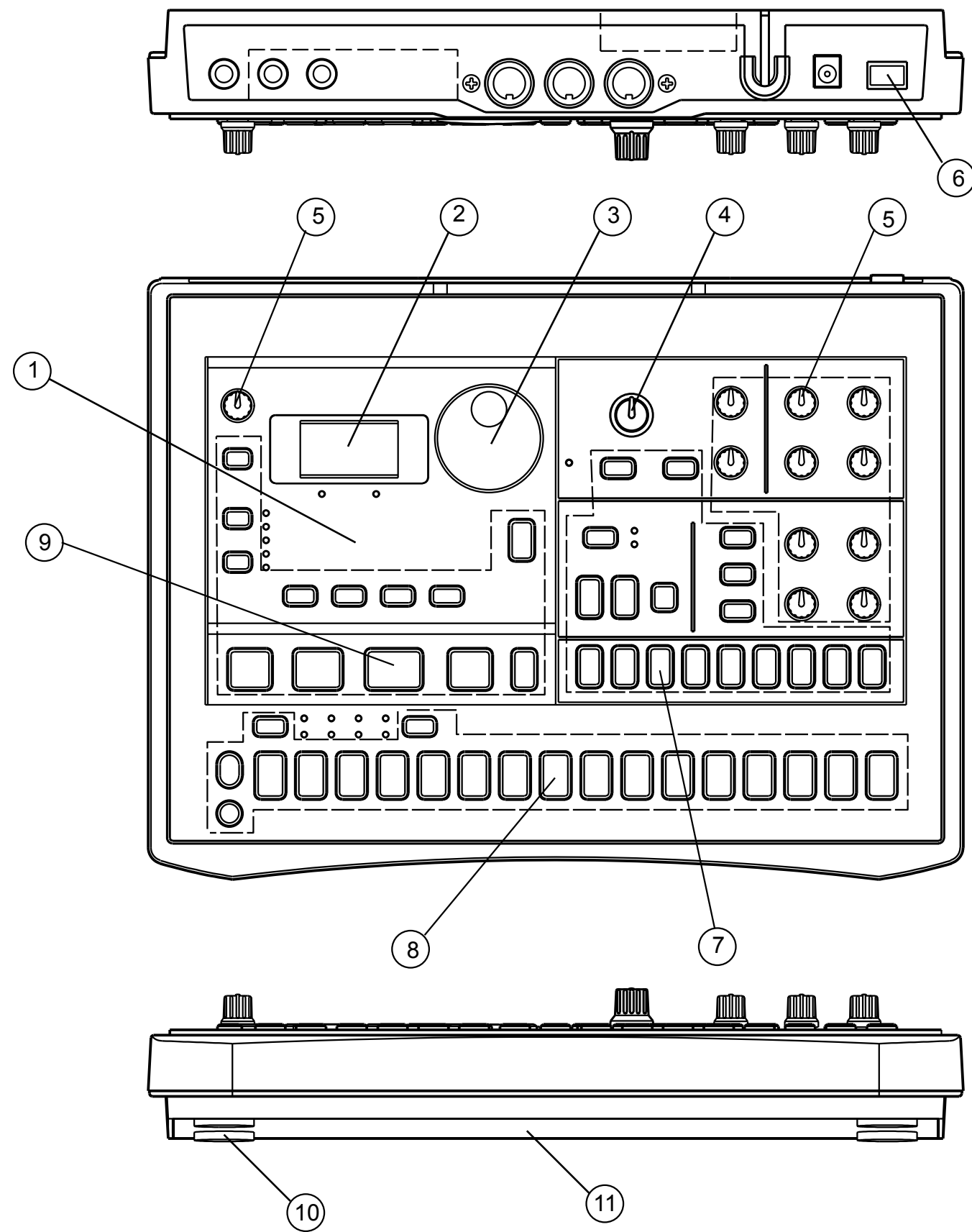

W: 300mm
 D: 222.5mm
 H: 55.4mm
 WEIGHT: 1.25Kg

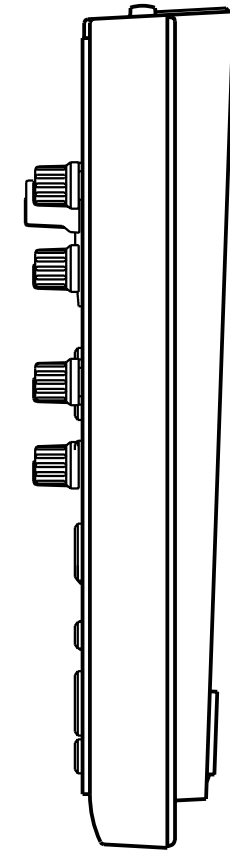

NO.	PART CODE	PART NAME	Q'TY
1	646077300	X-0220 UPPER CASE KOC-E10163-4	1
2	630024300	X-514/7 8 SEGMENT WINDOW	1
3	620036000	X-610 ENCODER KNOB(BK)	1
4	620036100	KNOB P82-90G (BK/L.GR)	1
5	620033900	KNOB P422-90G(BK/L.GR)	11
6	620018200	POWER SW KNOB KOC-E40224-1	1
7	620038700	X-829S RUBBER KEY S(19KEYS)	1
8	620035500	X-829B RUBBER KEY F(20KEYS)	1
9	620035600	X-829P/B RUBBER KEY L(13KEYS)	1
10	500018300	RUBBER LEG 3X22X3 KOC-F48035	4
11	641041547	X-829P/B BOTTOM COVER C30525	1

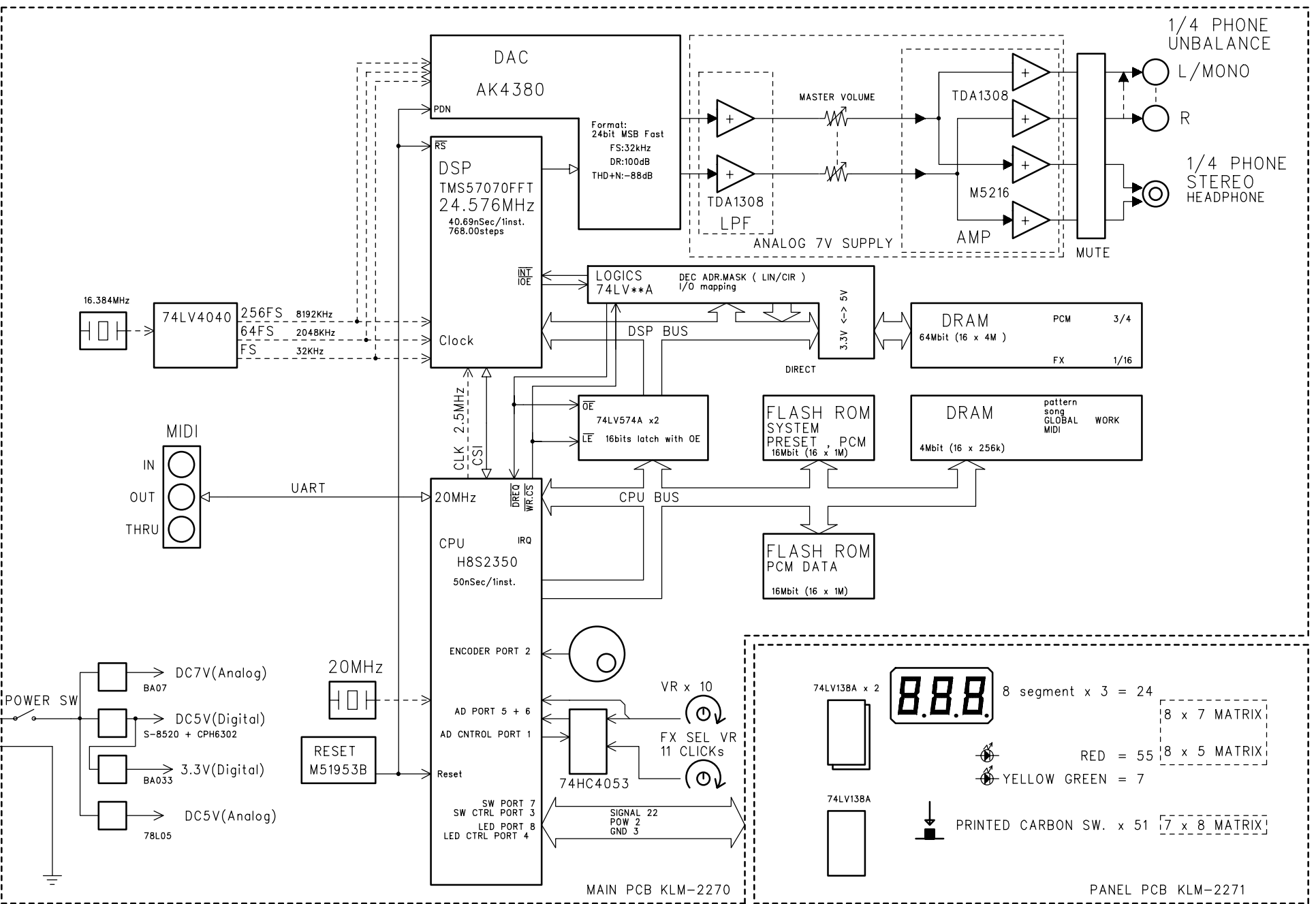
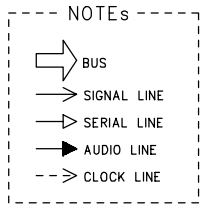

△				
△				
△				
△				
△				
MARK	REVISION REASON	DATE	REVISED BY	

DRAWN BY	DESIGNED BY	CHECKED BY	MODEL X-0220 (EM-1)
M.Kuwabara		TITLE BLOCK DIAGRAM	
KORG		DRAWING NO. KOD-B40226	DATE '01.04.09

PANEL PCB

KLM-2271

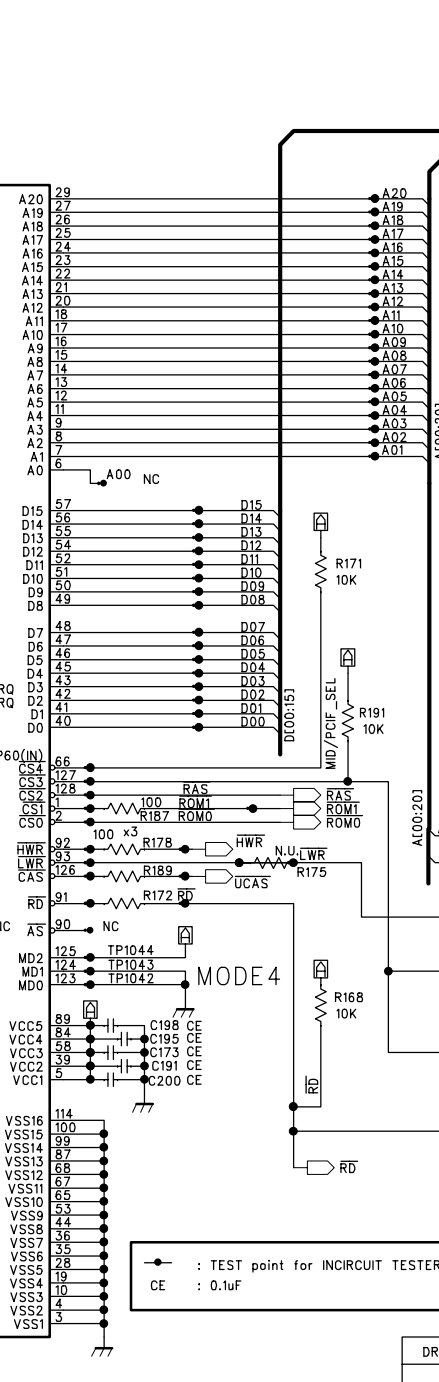
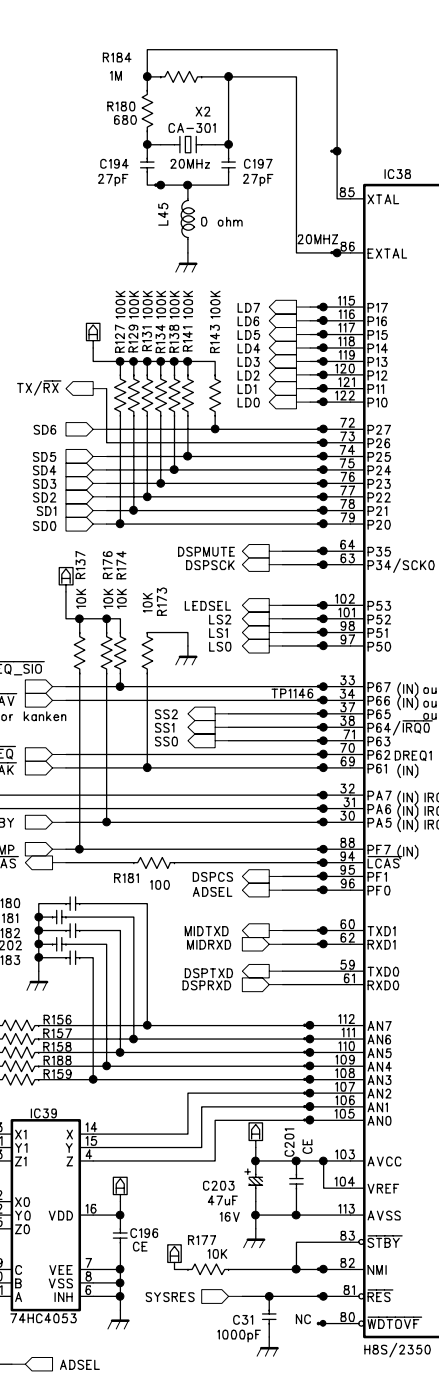
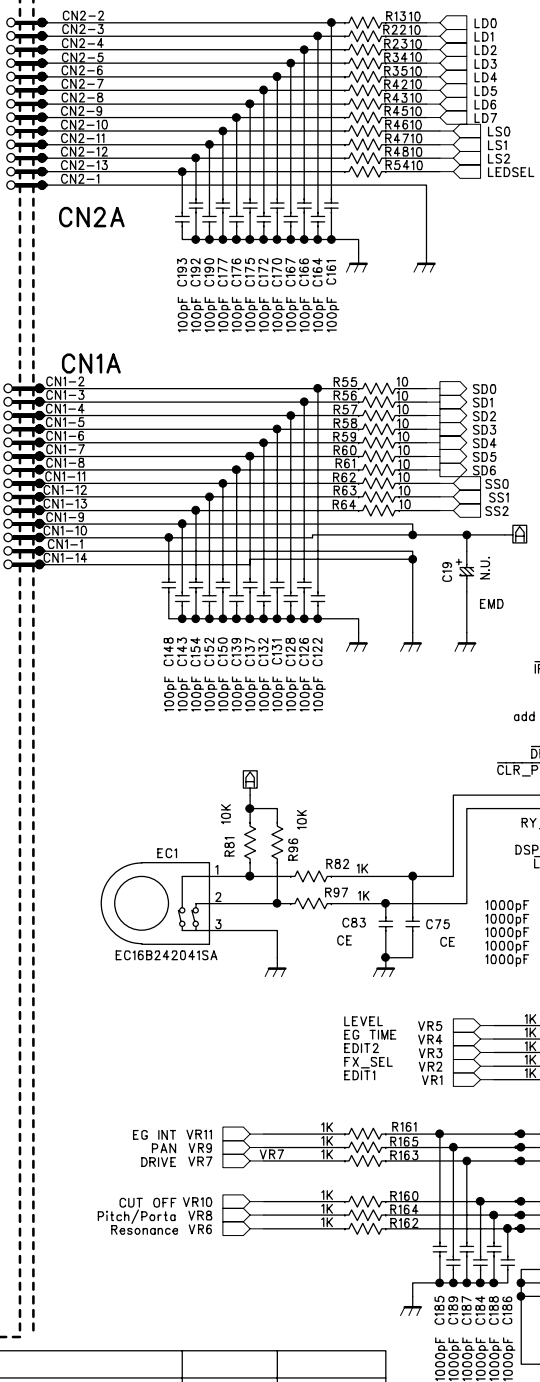

KLM-2270
CPU
1/6

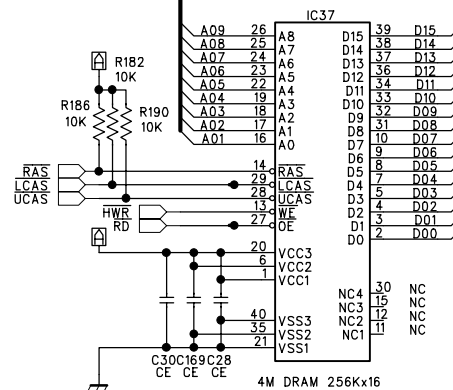
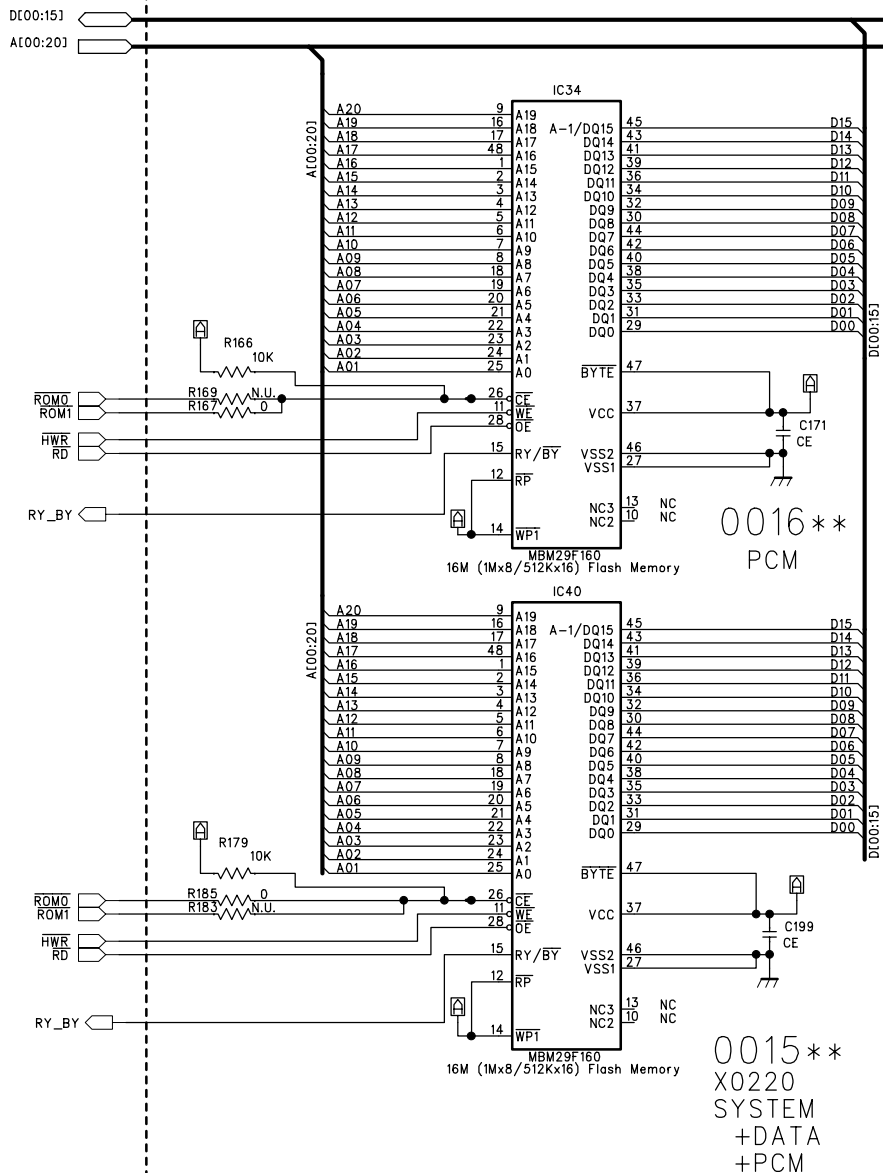

● : TEST point for INCIRCUIT TESTER
CE : 0.1uF

△			
△			
△			
△			
△			
MARK	REVISION REASON	DATE	REVISED BY

FileName : KLM2270.SCH

DRAWN BY	DESIGNED BY	CHECKED BY	MODEL	EM-1 (X-0220)
G6	G6			
M.Kuwabara	M.Kuwabara			
TITLE			KLM-2270 2/6	
MEMORY FOR CPU			CIRCUIT DIAGRAM	
DRAWING NO.		DATE		
KORG		KOD-A40491		2001.04.06

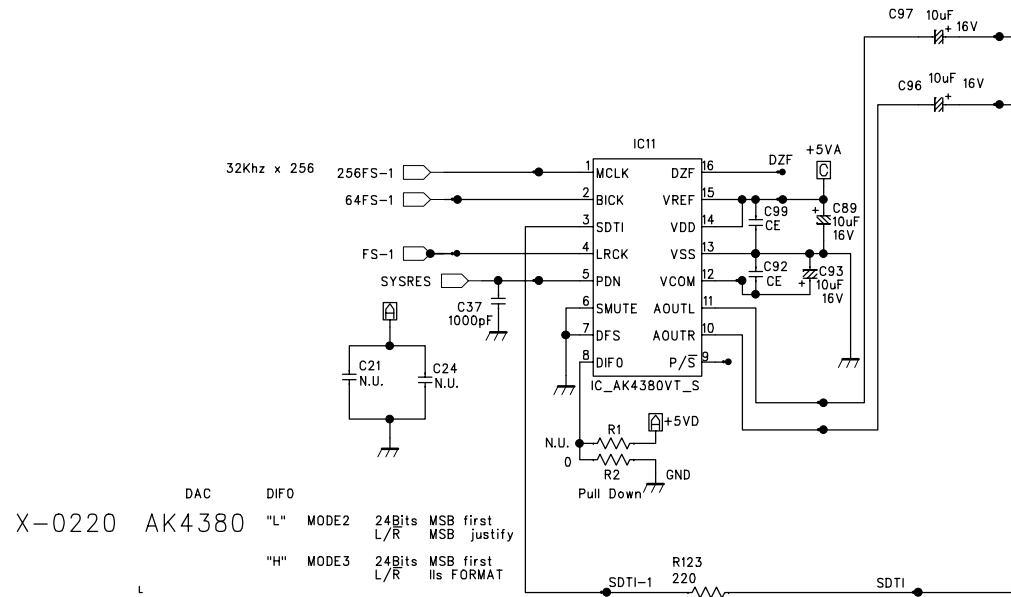

DAC DIF0
 X-0220 AK4380 "L" MODE2 24bits MSB first L/R MSB justify
 "H" MODE3 24bits MSB first L/R ILS FORMAT

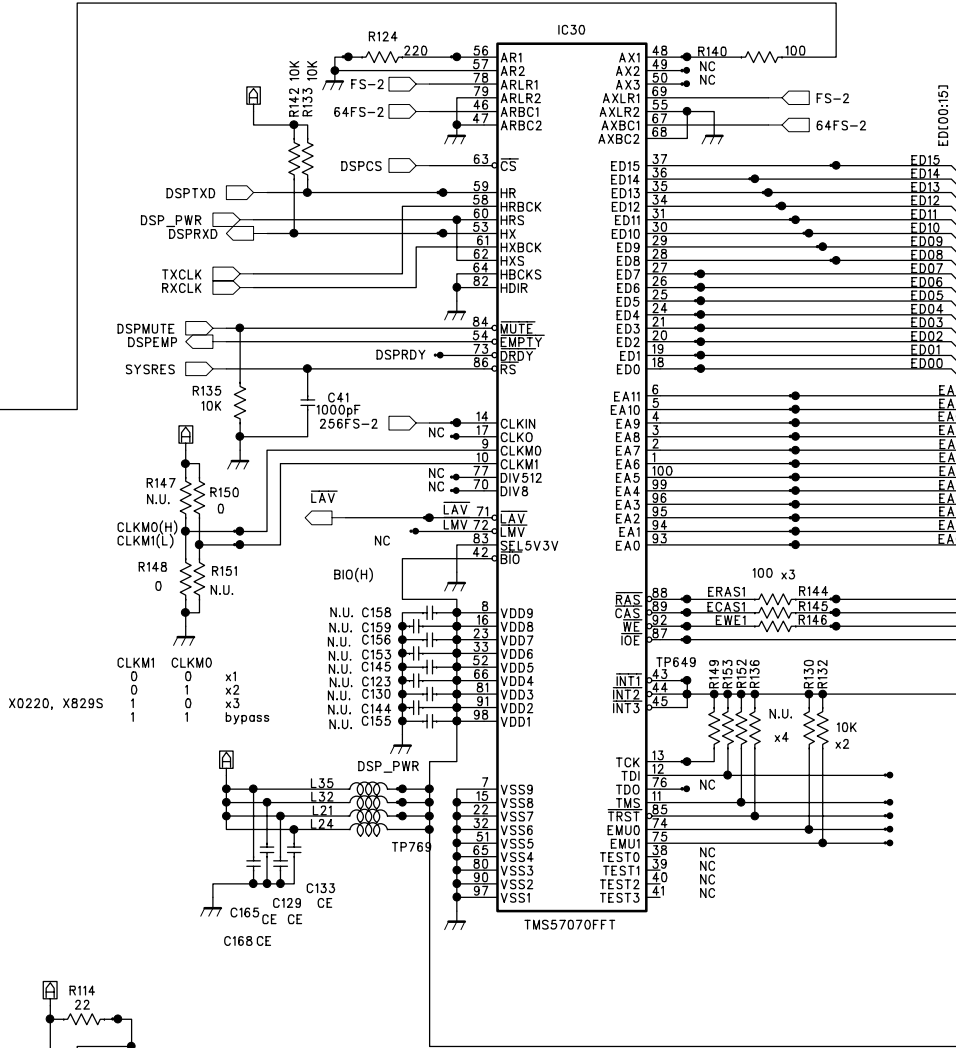
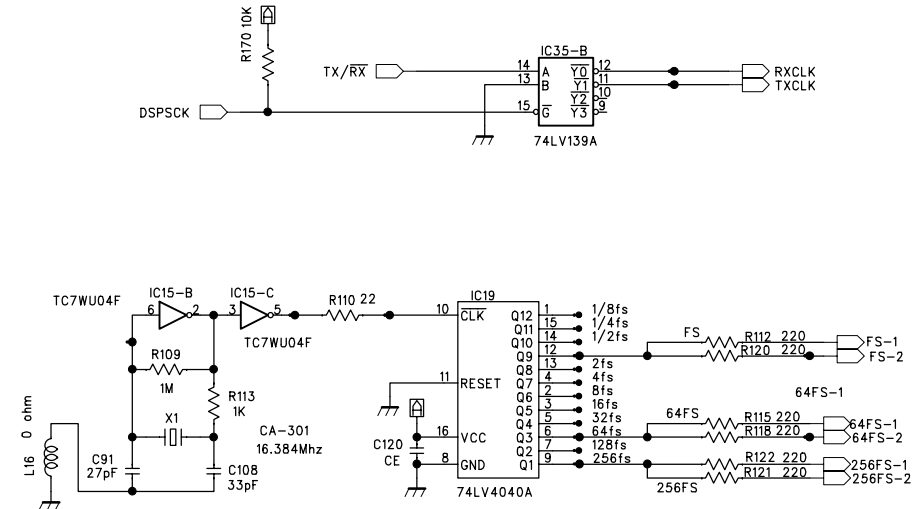
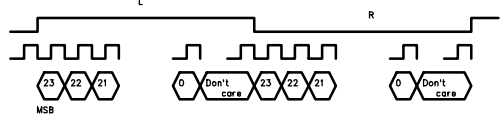

X0220, X829S

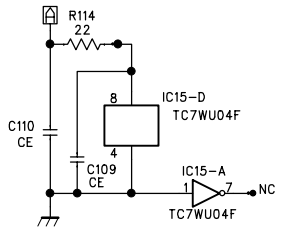
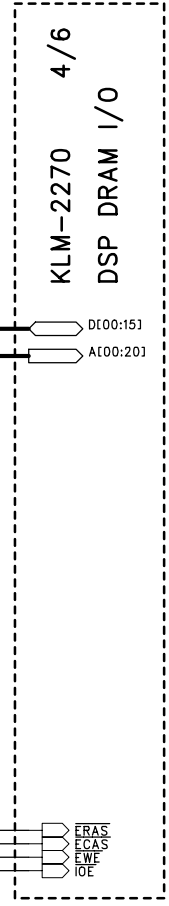

● : TEST point for INCIRCUIT TESTER
 CE : 0.1uF

FileName : KLM2270.SCH

DRAWN BY	DESIGNED BY	CHECKED BY	MODEL	EM-1 (X-0220)
G6	G6		TITLE	KLM-2270 3/6
M.Kuwabara	M.Kuwabara		DSP DAC CIRCUIt DIAGRAM	

KORG	DRAWING NO.	DATE
	KOD-A40492	2001.04.06

△			
△			
△			
△			
△			
MARK	REVISION REASON	DATE	REVISED BY

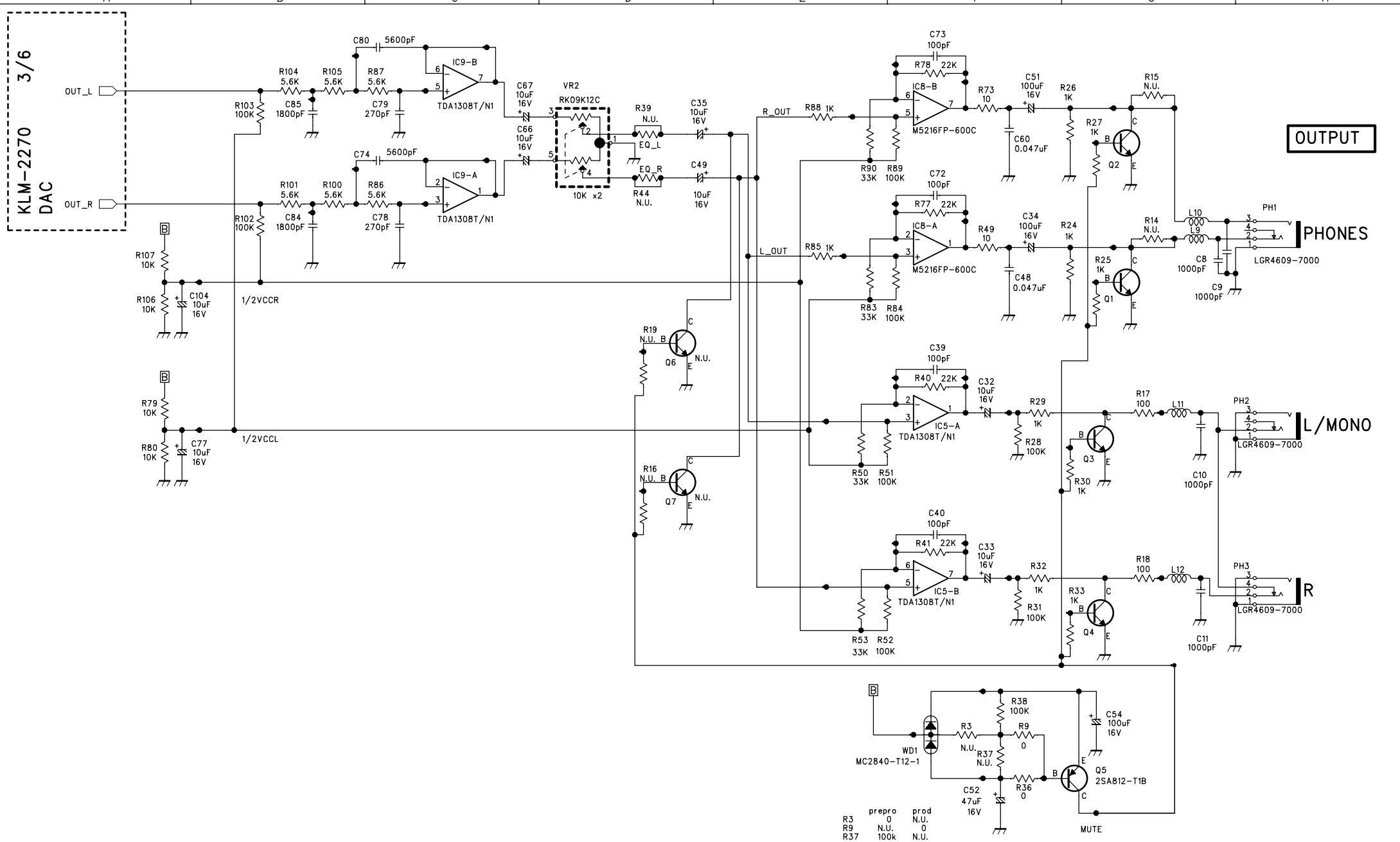

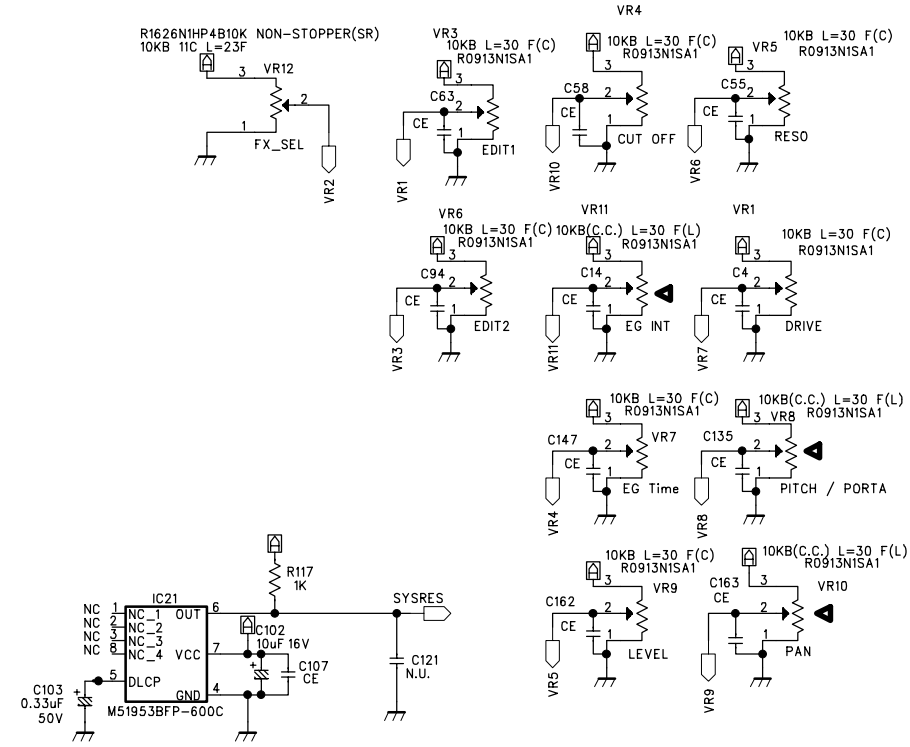
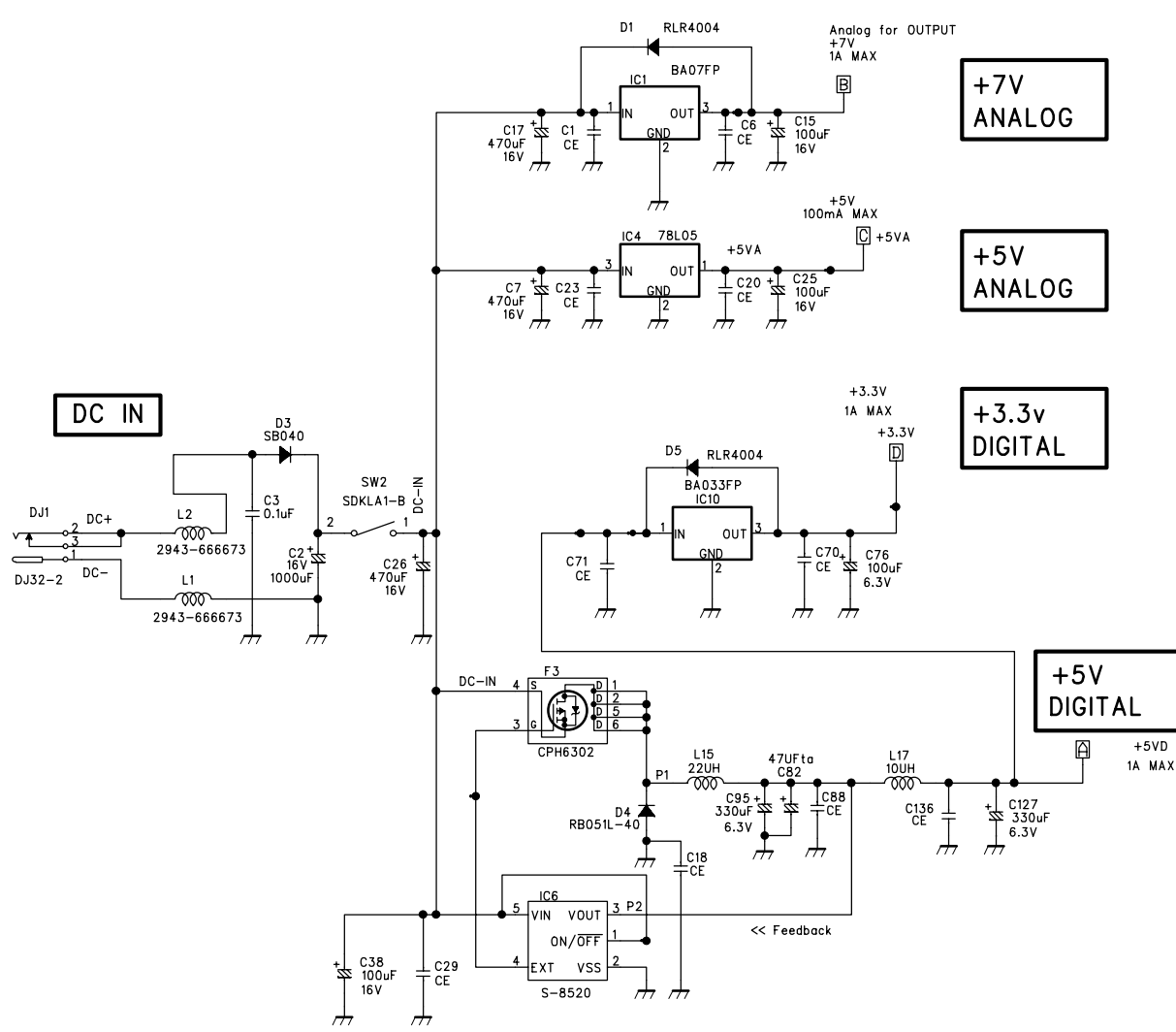

X-0220 R0913N1SA1 10KB L=30F(C)
R0K1 R0913N1SA1 10KB CC L=30F(L)

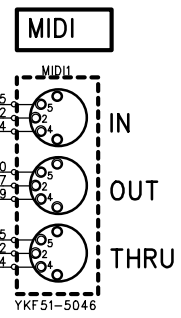

● : TEST point for INCIIRCUIT TESTER
CE : 0.1uF

△			
△			
△			
△			
△			
MARK	REVISION REASON	DATE	REVISED BY

FileName : KLM2270.SCH

DRAWN BY G6 M.Kuwabara	DESIGNED BY G6 M.Kuwabara	CHECKED BY	MODEL EM-1 (X-0220)
TITLE POWER MIDI VR CIRCUIT DIAGRAM			6/6
KORG		DRAWING NO. KOD-A40495	DATE 2001.04.06

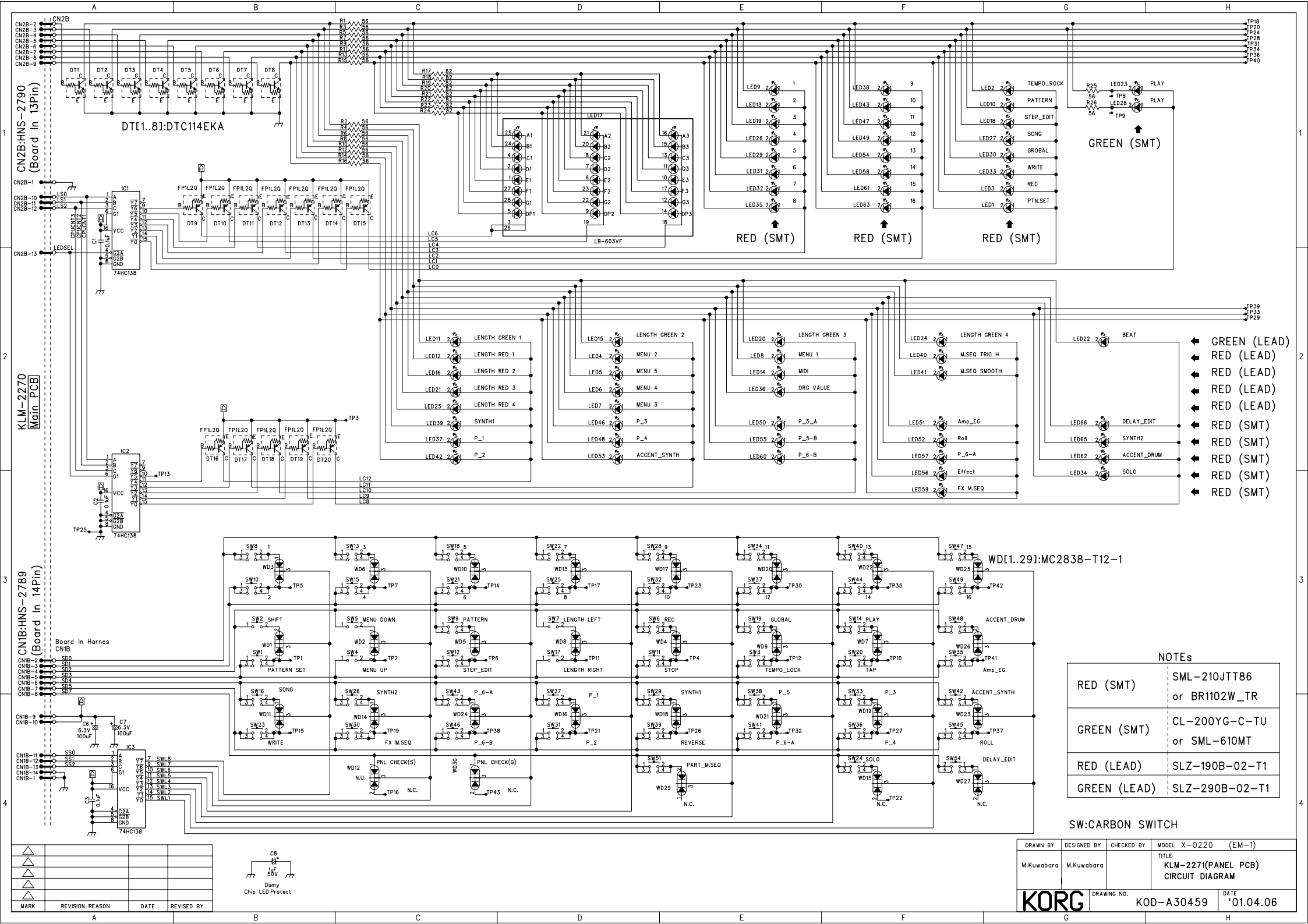

EM-1

How to start and operate the test mode:

[■] + [TAP] + POWER ON: FULL TEST

[●] + [■] + POWER ON: INTERNAL TEST SKIP

Operations during the test mode:

Internal test:

[SHIFT]+[16]: Error skip

External test:

[16]: STEP UP

[15]: STEP DOWN

[▲]: ITEM UP

[▼]: ITEM DOWN

NOTE: The power must NOT be turned OFF during the operation of the internal test. If it occurs, the data in the flash ROM will be erased and the unit will not function any more.

PART CODE	PART NAME	NOTE	QTY
001227000	PCB ASSY KLM-2270 EM-1	EM-1 M.PART	1
001227100	PCB ASSY KLM-2271 EM-1	EM-1 M.PART	1
235007410	AEC 16V 1000UF RE2-16V102MMA	KLM-2270	1
254003347	AEC 16V470 RE2-16V471MMA-T2:TR	KLM-2270	3
254081410	AEC 6.3V100UF RVS-6V101M-R(TS)	KLM-2271	2
254081410	AEC 6.3V100UF RVS-6V101M-R(TS)	KLM-2270	1
254083310	AEC 16V 10UF RVS-16V100M-R(TS)	KLM-2270	14
254083347	AEC 16V 47UF RVS-16V470M-R(TS)	KLM-2270	2
254086033	AEC50V0.33UF RVS-50VR33M-R(TS)	KLM-2270	1
254086110	AEC 50V 1UF RVS-50V010M-R(TS)	KLM-2271	1
254701433	6.3V 330UF RV-6V331MG68-R (TS)	KLM-2270	2
254703410	16V 100UF RV-16V101MG68-R (TS)	KLM-2270	6
304000070	TR 2SA812-T1B (M5-7) (TS)	KLM-2270	1
304020230	TR 2SC3661-TA/TB(3K) (TS)	KLM-2270	6
304020380	DIGITAL TR FP1L2Q-T1B (TS)	KLM-2271	12
304050140	DIGITAL TR DTC114EKA T146(TS)	KLM-2271	8
304060250	FET CPH6302-TL(TS)	KLM-2270	1
312052000	LED LB603VF	KLM-2271	1
314001400	DIODE RLS-73 TE-11 (TS)	KLM-2270	1
314010340	LED SLZ-190B-02-T1(TR)	KLM-2271	13
314010350	LED SLZ-290B-02-T1(TR)	KLM-2271	5
314029500	DIODE SB040-G23(TA)	KLM-2270	1
314029700	DIODE RLR4004 TE-21 (TS)	KLM-2270	2
314029800	LED CL-200YG-C-TU (TS)	KLM-2271	2
314029900	LED SML-210JTT86 (TS)	KLM-2271	42
314030700	SCHOTTKY DIODE RB051L-40TE25	KLM-2270	1
315000500	DOUBLE DIODE MC-2840-T12-1(TS)	KLM-2270	1
315000600	DOUBLE DIODE MC2838-T12-1 (TS)	KLM-2271	29
320004649	IC HD6412350(D12350F20) (S)	CPU	1
320012291	MBM29F160BE-70PFTN-K(X0220A):S	16M Flash(SYSTEM)	1
320012292	MBM29F160BE-70PFTN-K(X0220B):S	16M Flash(DATA)	1
320021156	IC TMS57070FFT (S)	DSP	1
324003010	IC TC7WU04F TE12L (TS)	Inverter	1
324004168	IC HD74HC4053FPEL (TS)	HC	1
324004176	IC HD74HC05FPEL (TS)	HC	1
324007006	IC BA07FP-E2 (TS)	REG	1
324007009	IC BA033FP-E2 (TS)	REG	1
324009004	IC NJM78L05UA-TE1 (TS)	REG	1
324011004	IC M5216FP-600C (TS)	OP-AMP	1
324011012	IC M51953BFP-600C (TS)	RESET	1
324017016	IC EM614163A-40J(TS)	256k x 16(4M) DRAM	1
324018010	IC AK4380-VT-E2 (TS)	DAC	1
324021014	IC SN74LV138ANS-EL (TS)	LV-A	3
324021103	IC SN74LV32APWR (TS)	LV-A	1
324021104	IC SN74LV74APWR (TS)	LV-A	1
324021105	IC SN74LV245APWR (TS)	LV-A	2
324021106	IC SN74LV139APWR (TS)	LV-A	1
324021108	IC SN74LV138APWR (TS)	LV-A	1

PART CODE	PART NAME	NOTE	QTY
324021109	IC SN74LV244APWR (TS)	LV-A	2
324021110	IC SN74LV574APWR (TS)	LV-A	2
324021113	IC SN74LV4040APWR (TS)	LV-A	1
324023007	IC S-8520F50MC-B0J-T2(TS)	REG	1
324027008	IC GM71VS65163CLT-5(T):TS	4M x 16 (64M) DRAM	1
324038005	IC TDA1308T/N1 (TS)	OP-AMP	2
334000600	PHOTO COUPLER PC-410K (TS)	KLM-2270	1
335011000	CRYSTAL OSC CA-301 20.00MHZ	KLM-2270	1
335011800	CRYSTAL OSC CA-301 16.384MHZ	KLM-2270	1
362009018	VR RK09K12C0D08	KLM-2270	1
362009038	VR R0913N1SA1 B10K CC L=30F	KLM-2270	3
362009039	VR R0913N1SA1 B10K L=30F	KLM-2270	7
362009040	R1626N1HP4 B10K 11C L23 NSSR	KLM-2270	1
370004500	REC EC16B242041S	KLM-2270	1
375014800	PSW SDKLA10200	KLM-2270	1
402004600	COIL 2943-666673	KLM-2270	2
402006200	COIL C10-FR/33331 22UH(TR)	KLM-2270	1
402400400	COIL C8-E/33331 10UH	KLM-2270	1
404001070	CHIP SOLID INDUCTOR BLM11B102S	KLM-2270	14
405012000	AC ADAPTER KA-181(100V/9V-600M	EM-1 JP	1
405012100	AC ADAPTER KA-183(120V/9V-600M	EM-1 CN	1
405012100	AC ADAPTER KA-183(120V/9V-600M	EM-1 US	1
405012100	AC ADAPTER KA-183(120V/9V-600M	EM-1 EX	1
405012200	AC ADAPTER KA-189(230V/9V-600M	EM-1 WG	1
405012200	AC ADAPTER KA-189(230V/9V-600M	EM-1 GE	1
405012200	AC ADAPTER KA-189(230V/9V-600M	EM-1 FR	1
405012300	AC ADAPTER KA-186(UK/9V-600MA)	EM-1 UK	1
450003100	PHONE JACK LGR4609-7000	KLM-2270	3
454012700	DC POWER JACK DJ32-2	KLM-2270	1
472071301	CONNECTOR SIDE S13B-PH-K-S (U)	KLM-2270	1
472071401	CONNECTOR SIDE S14B-PH-K-S (U)	KLM-2270	1
475002789	HARNESS HNS-2789 BOARD IN	KLM-2271	1
475002790	HARNESS HNS-2790 BOARD IN	KLM-2271	1
480010200	3 LINKAGE DIN SOCKET YKF51-504	KLM-2270	1
500018300	RUBBER LEG 3X22X3 KOC-F48035	EM-1 M.PART	4
540021900	PLASTIC SUPPORT PS-610	EM-1 M.PART	6
620018200	POWER SW KNOB KOC-E40224	EM-1 M.PART	1
620033900	KNOB P422-90G(BK/L.GR)	EM-1 M.PART	11
620035500	X-829B RUBBER KEY F(20KEYS)	EM-1 M.PART	1
620035600	X-829P/B RUBBER KEY L(13KEYS)	EM-1 M.PART	1
620036000	X-610 ENCODER KNOB(BK)	EM-1 M.PART	1
620036100	KNOB P82-90G (BK/L.GR)	EM-1 M.PART	1
620038700	X-829S RUBBER KEY S(19KEYS)	EM-1 M.PART	1
630024300	X-514/7 8 SEGMENT WINDOW	EM-1 M.PART	1
630025703	X-829P/B SHIELD SHEET F40869	EM-1 M.PART	5
630034100	X-0220 ALMINIUM SHEET F40949	EM-1 M.PART	1
641041547	X-829P/B BOTTOM COVER C30525	EM-1 M.PART	1
644007700	GND SPRING KOC-C46014	EM-1 M.PART	2

PART CODE	PART NAME	NOTE	QTY
644009000	X-8510 GND SPRING(K) KOC-C4116	EM-1 M.PART	3
646077300	X-0220 UPPER CASE KOC-E10163-4	EM-1 M.PART	1