

DWG. NO.	990-049-00	SHT	7	REV:	S	1
ECO#	REV:	DESCRIPTION	REV. BY:	APP. BY:	DATE	

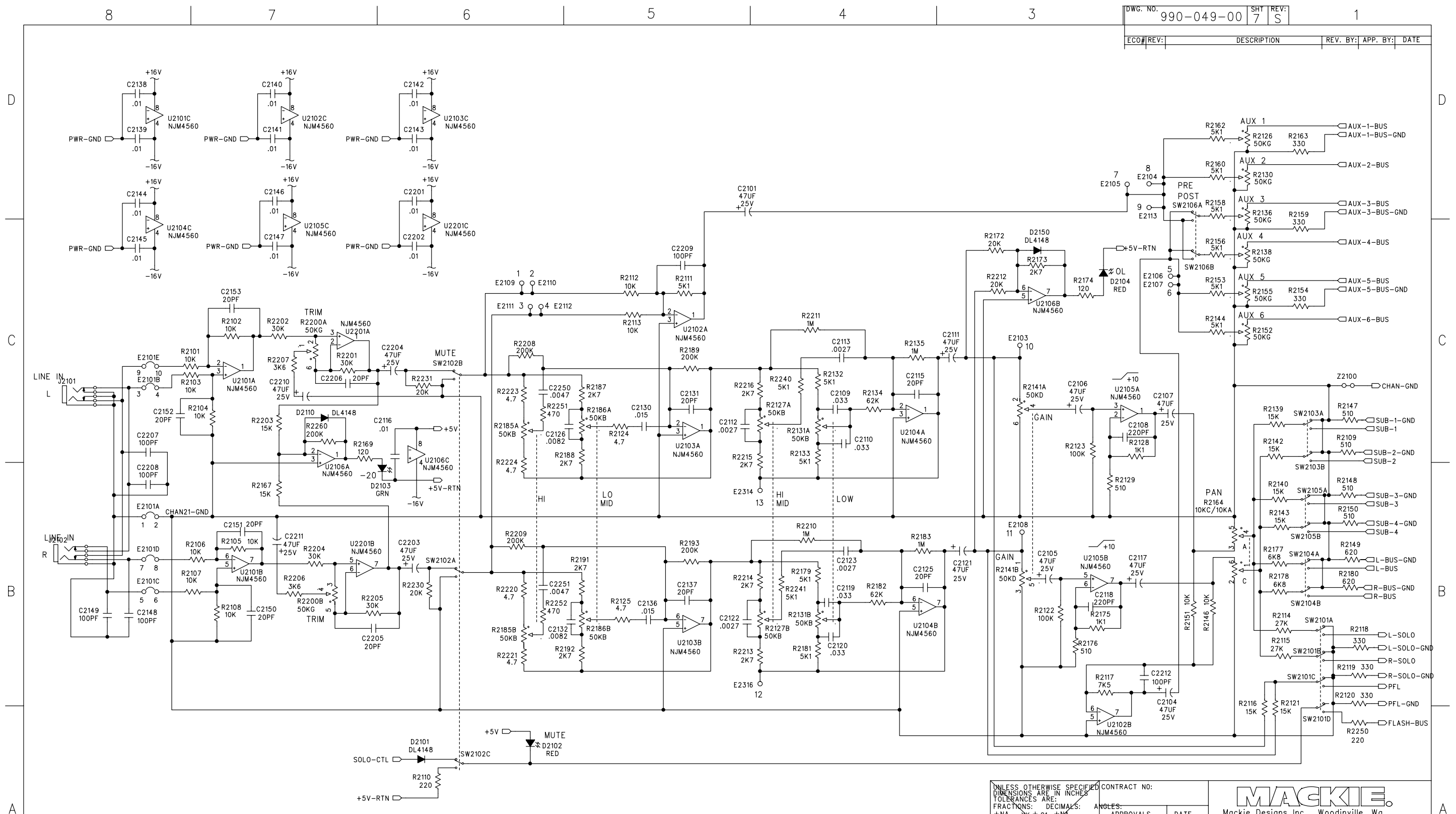

CHANNEL 21-24, CHANNEL 21-22 shown (stereo channels)

UNLESS OTHERWISE SPECIFIED DIMENSIONS ARE IN INCHES. TOLERANCES ARE:		CONTRACT NO:		MACKIE Mackie Designs Inc. Woodinville, Wa.	
FRACTIONS: ±NA .XX ±.01 ±NA .XXX ±.005	DECIMALS: .XX ±.01 ±NA .XXX ±.005	APPROVALS	DATE		
MATERIAL: SEE NOTES	FINISH: SEE NOTES	DRAWN: trh	CHECKED:	SCHEMATIC MASTER BOARD, 24*4	
DO NOT SCALE DRAWING		ISSUED:	ENG:	SIZE D	DWG. NO. 990-049-00
		MFG:		SCALE: NONE	REV. S
					SHEET 7 OF 13

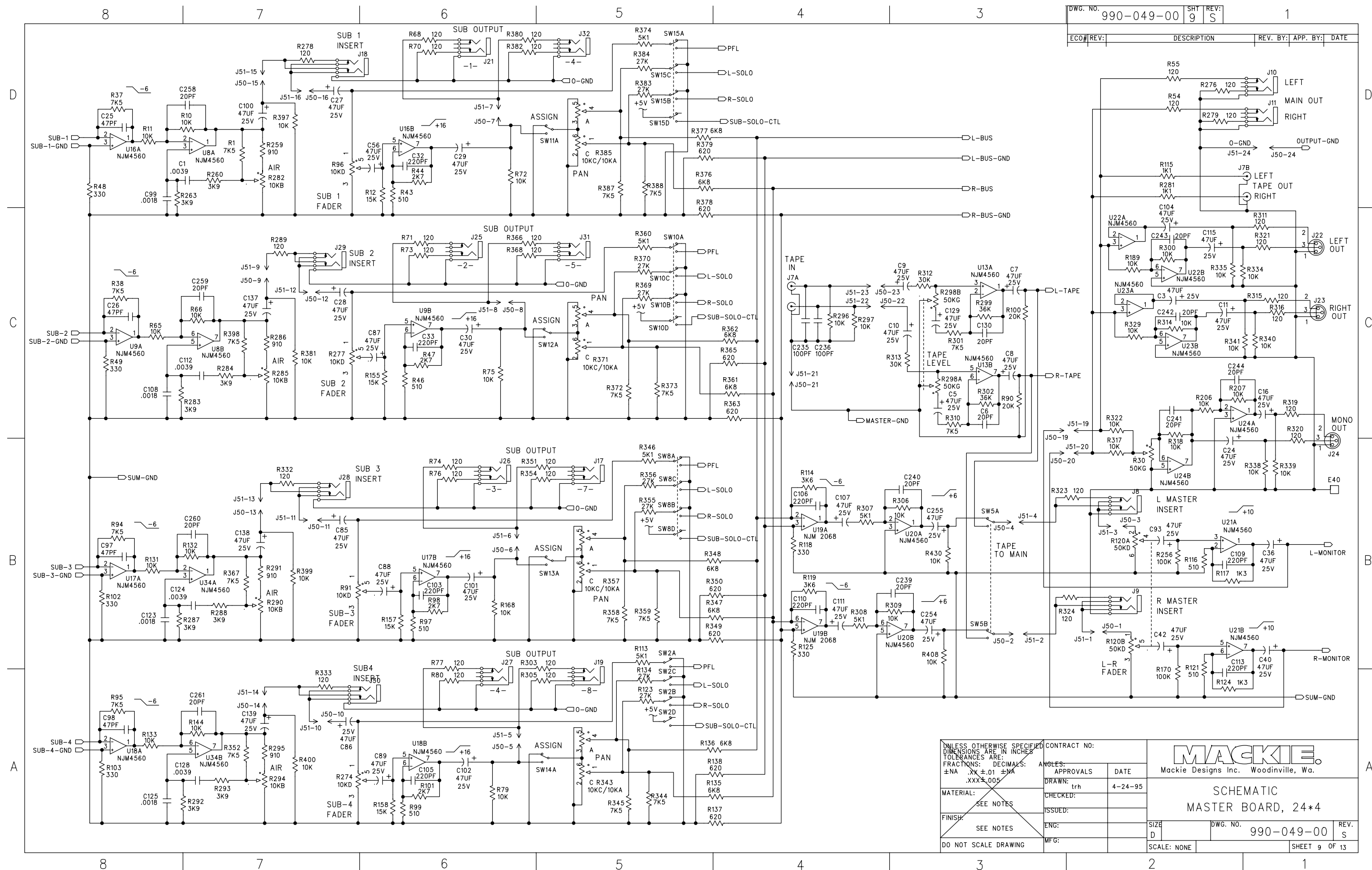

DWG. NO. 990-049-00 SHY REV: 9 S 1

ECO# REV: DESCRIPTION REV. BY: APP. BY: DATE

UNLESS OTHERWISE SPECIFIED DIMENSIONS ARE IN INCHES TOLERANCES ARE:		CONTRACT NO:		Mackie Designs Inc. Woodville, Wa.	
FRACTIONS: ±NA	DECIMALS: .XX ±.01 ±NA	ANGLES:	DATE		
MATERIAL:	SEE NOTES	DRAWN: lrh	4-24-95	SCHEMATIC MASTER BOARD, 24*4	
FINISH:	SEE NOTES	CHECKED:	ISSUED:	SIZE D	DWG. NO. 990-049-00
DO NOT SCALE DRAWING		ENG:	SCALE: NONE	SHEET 9 OF 13	REV. S

49-2 MASTER BOARD 49 Rev S

DWG. NO.	990-049-00	SHT	REV:	10	S	1
ECO#	REV:	DESCRIPTION	REV. BY:	APP. BY:	DATE	

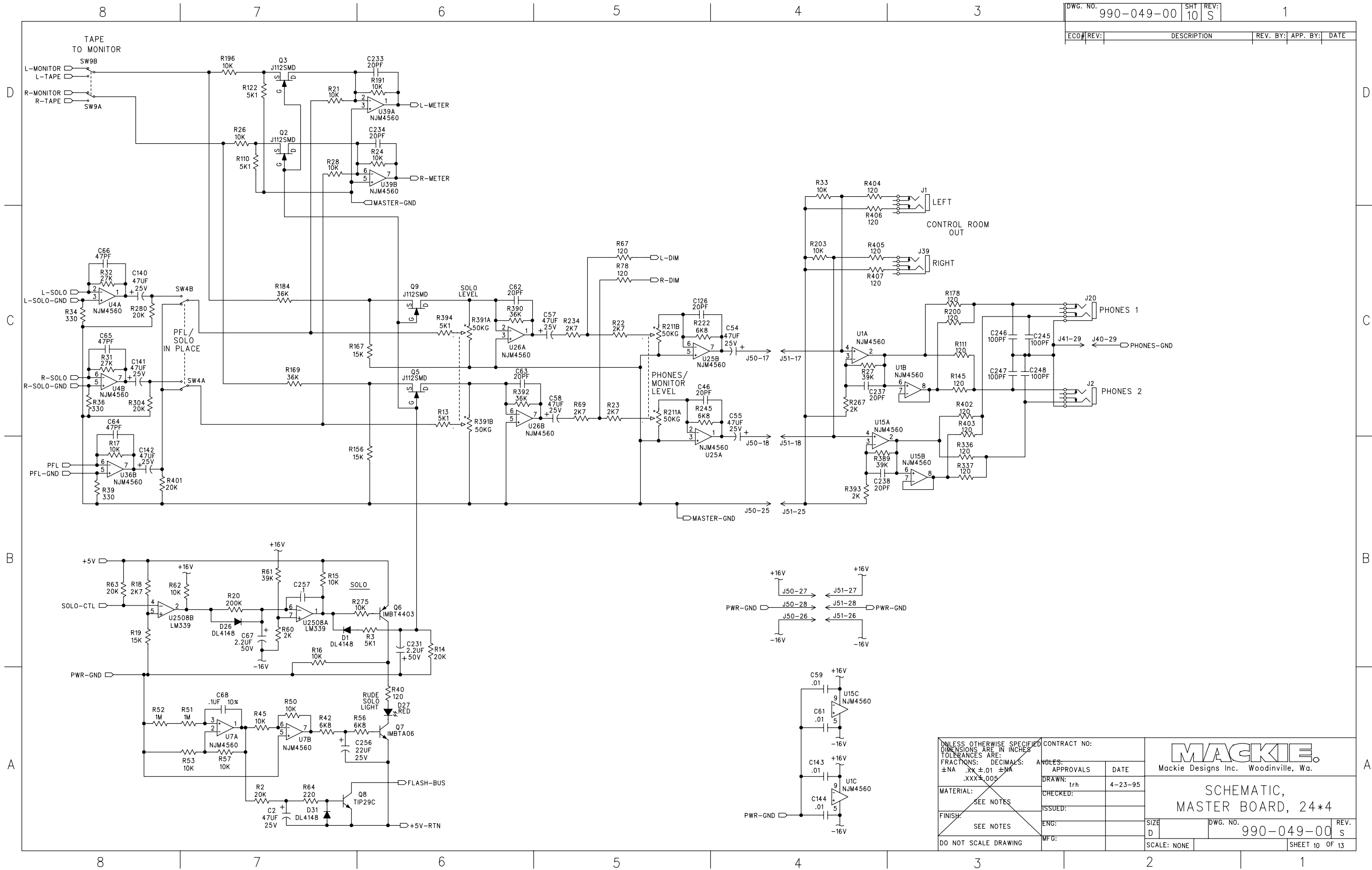

UNLESS OTHERWISE SPECIFIED DIMENSIONS ARE IN INCHES TOLERANCES ARE: FRACTIONS: .XX ±.01 ±MA DECIMALS: .XXX ±.005 MATERIAL: SEE NOTES FINISH: SEE NOTES DO NOT SCALE DRAWING	CONTRACT NO:		MACKIE Mackie Designs Inc. Woodinville, Wa.	
	APPROVALS	DATE		
	DRAWN: trh	4-23-95	SCHEMATIC, MASTER BOARD, 24*4	
	CHECKED:	ISSUED:	SIZE	DWG. NO.
ENG:	MFG:	D	990-049-00	S
SCALE: NONE		SHEET 10 OF 13		

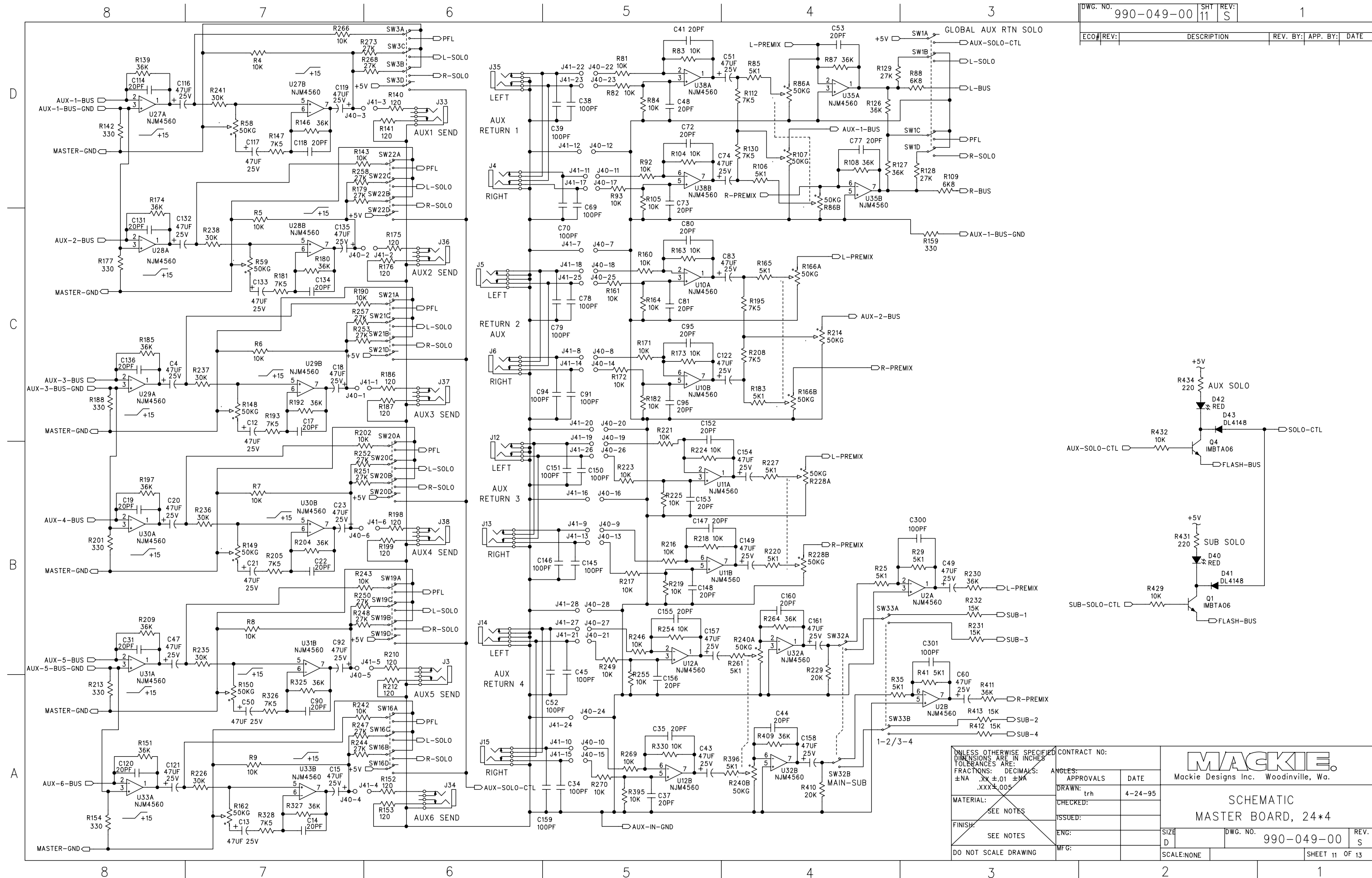

ECO#	REV:	DESCRIPTION	REV. BY:	APP. BY:	DATE
------	------	-------------	----------	----------	------

UNLESS OTHERWISE SPECIFIED DIMENSIONS ARE IN INCHES FRACTIONS: DECIMALS: ±.01 ±.005		CONTRACT NO:		Mackie Designs Inc. Woodville, Wa.	
MATERIAL:	SEE NOTES	APPROVALS:	DATE:		
FINISH:	SEE NOTES	CHECKED:	ISSUED:	SCHEMATIC MASTER BOARD, 24*4	
DO NOT SCALE DRAWING		ENG:	MFG:	SIZE: D	DWG. NO. 990-049-00 REV. S
				SCALE: NONE	SHEET 11 OF 13

49-4 MASTER BOARD 49 Rev S

DWG. NO.	990-049-00	SHT	REV:	12	S	1
ECO#	REV:	DESCRIPTION	REV. BY:	APP. BY:	DATE	

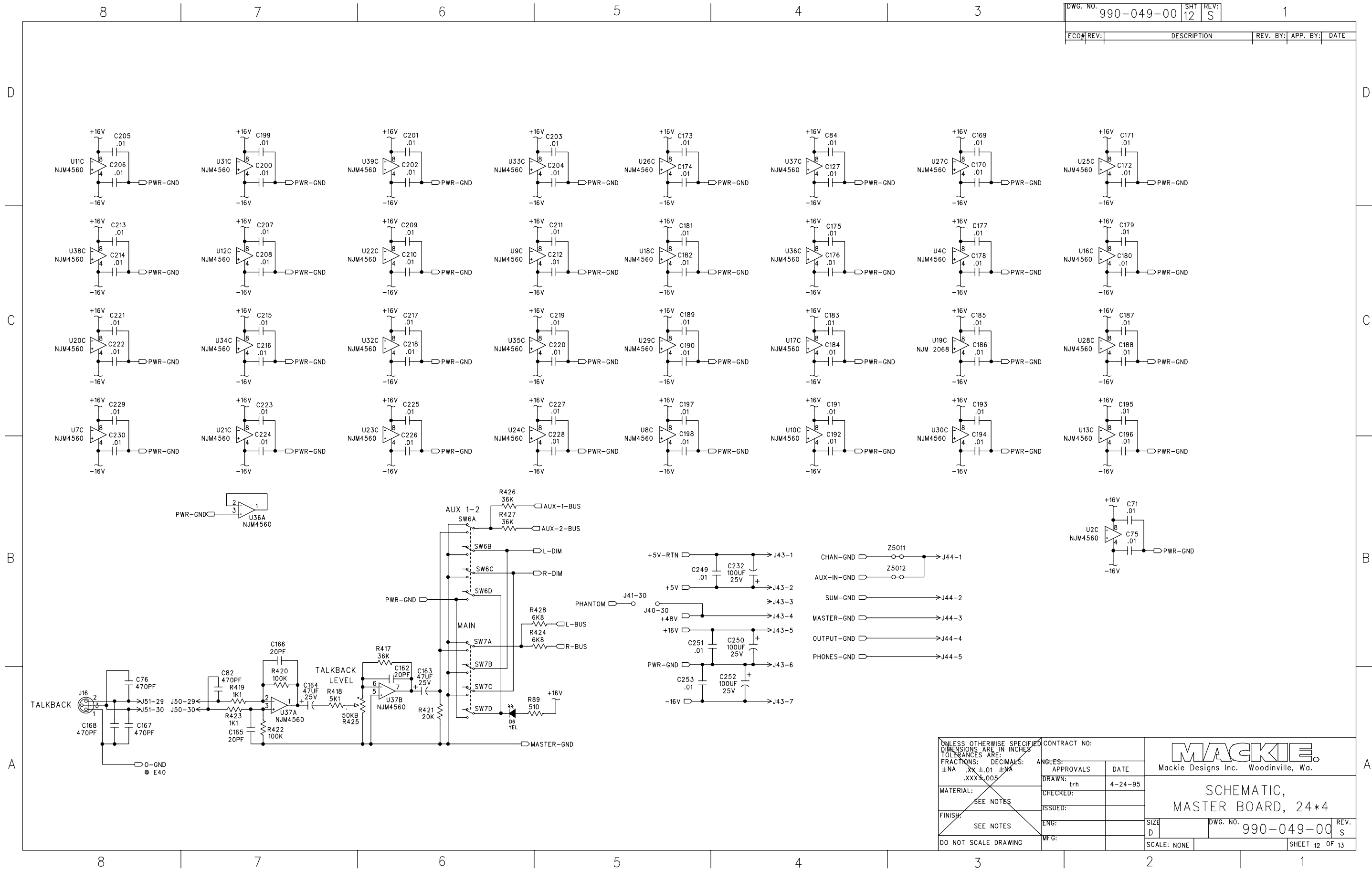

UNLESS OTHERWISE SPECIFIED DIMENSIONS ARE IN INCHES. TOLERANCES ARE: FRACTIONS: DECIMALS: ANGLES: ±NA .XX ±.01 ±NA .XXX ±.005		CONTRACT NO:		MACKIE Mackie Designs Inc. Woodinville, Wa.	
MATERIAL: SEE NOTES		APPROVALS	DATE		
FINISH: SEE NOTES		DRAWN: lrh	4-24-95	SCHEMATIC, MASTER BOARD, 24*4	
DO NOT SCALE DRAWING		CHECKED:	ISSUED:		
		ENG:		SIZE	DWG. NO. 990-049-00
		MFG:		SCALE: NONE	REV. S
				SHEET 12 OF 13	

- 620-015-00 JUMPER, FLEXSTRIP 30 COND 5"
- 620-016-00 JUMPER, FLEXSTRIP 20 COND 5"
- 620-017-00 JUMPER, FLEXSTRIP 30 COND 20"

- 760-011-00 BUTTON SW 9X9 MM
- 760-013-00 BUTTON SW RECT 9X5

- 706-009-00 SPACER, LED NYLON

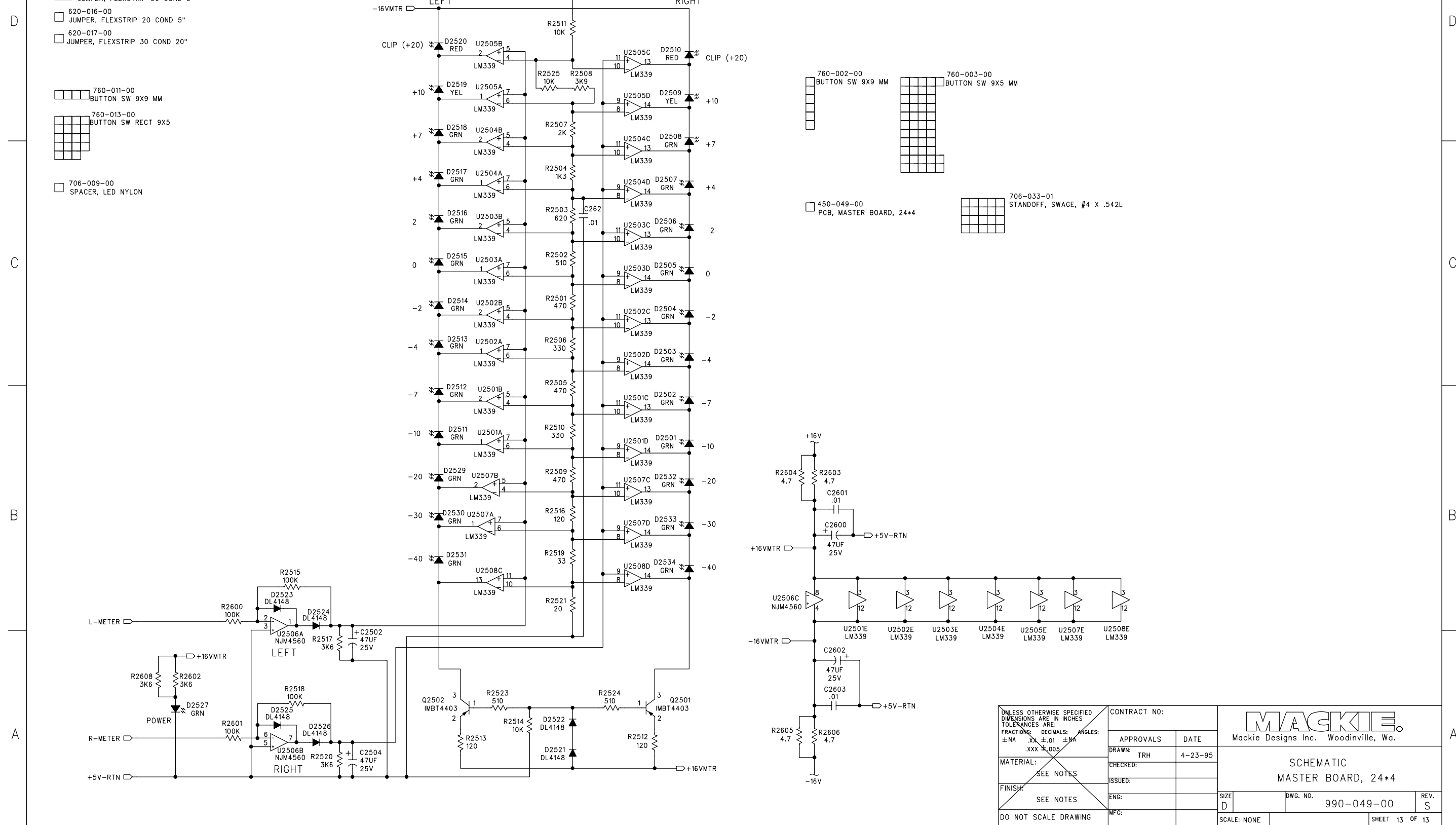

- 760-002-00 BUTTON SW 9X9 MM
- 760-003-00 BUTTON SW 9X5 MM

- 450-049-00 PCB, MASTER BOARD, 24*4
- 706-033-01 STANDOFF, SWAGE, #4 X .542L

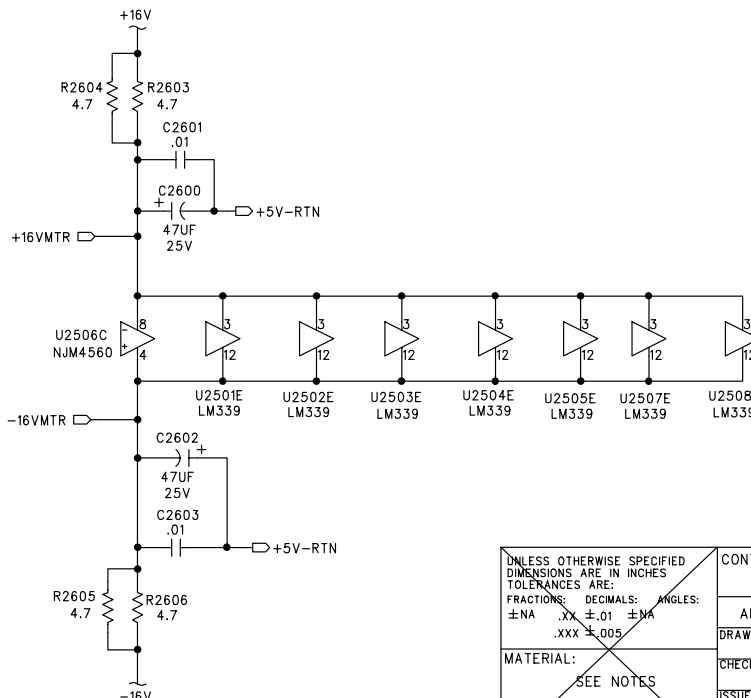

UNLESS OTHERWISE SPECIFIED DIMENSIONS ARE IN INCHES TOLERANCES ARE: FRACTIONS: DECIMALS: ANGLES: ±NA .XX ±.01 ±NA .XXX ±.005	CONTRACT NO:		Mackie Designs Inc. Woodinville, Wa.	
	APPROVALS:	DATE:		
	MATERIAL:	CHECKED:	SCHEMATIC	
	FINISH:	ISSUED:	MASTER BOARD, 24*4	
DO NOT SCALE DRAWING	ENG:	SIZE	DWG. NO.	REV.
	MFG:	SCALE: NONE	990-049-00	S
				SHEET 13 OF 13

49-6 MASTER BOARD 49 Rev S

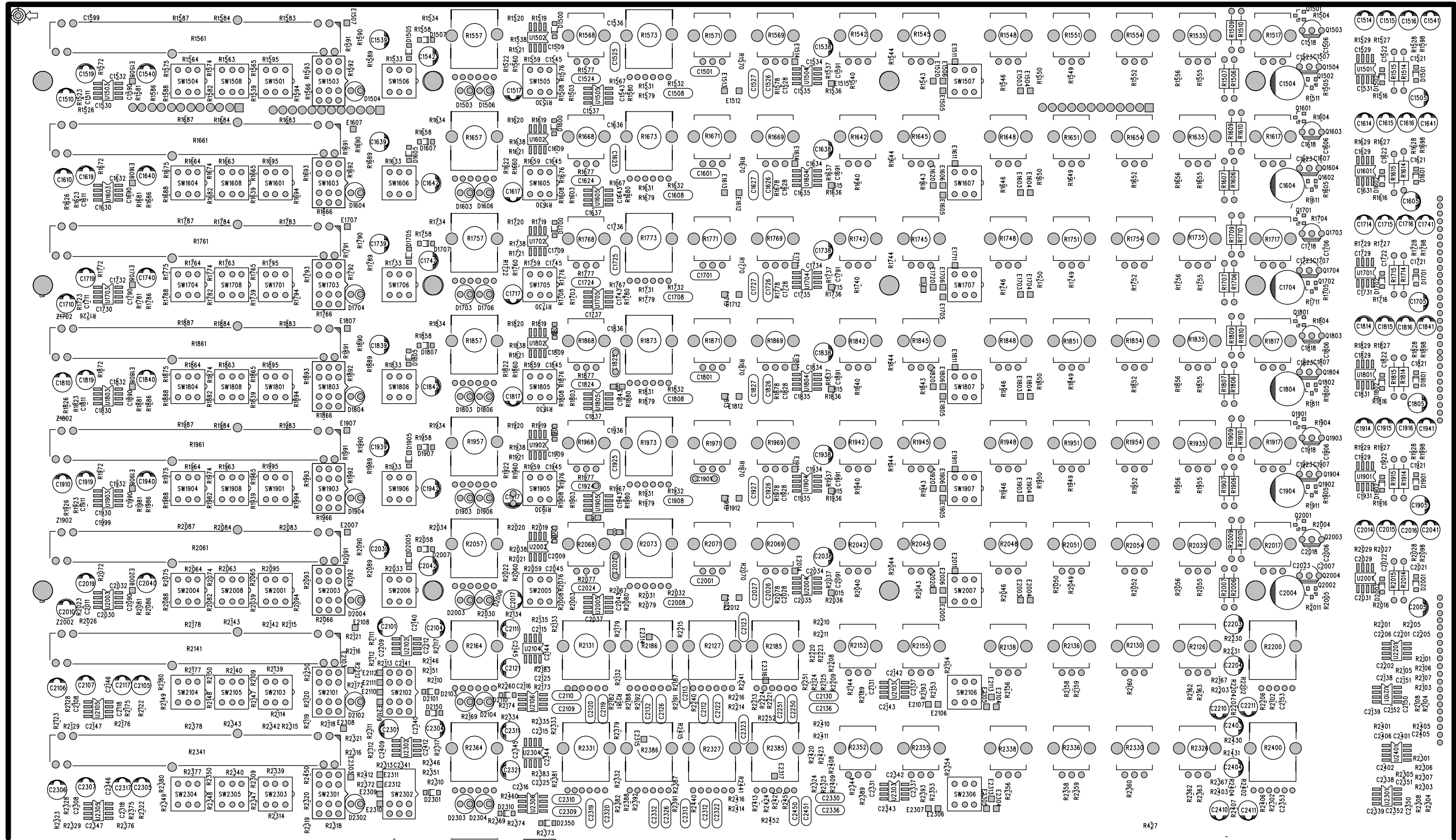

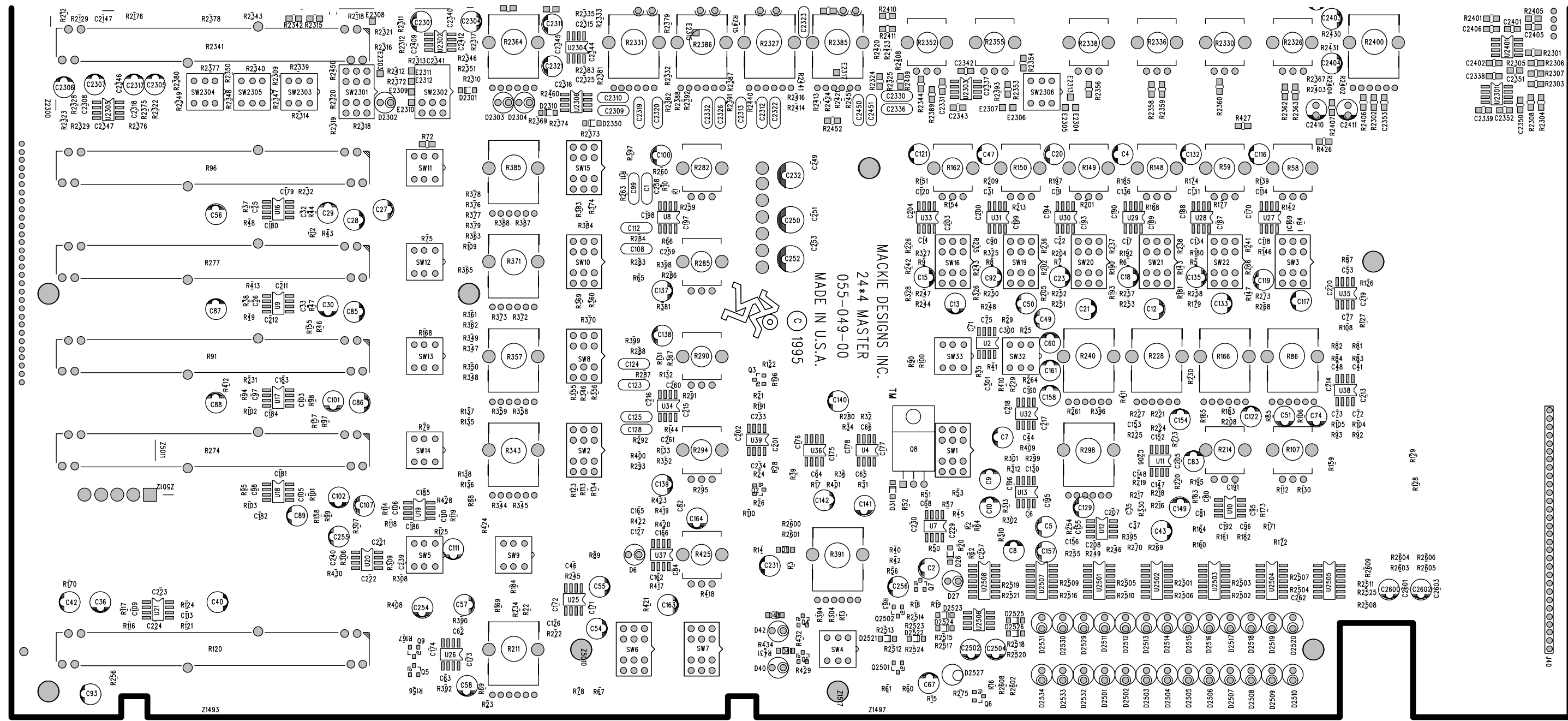

49-8 MASTER BOARD 49 Rev S

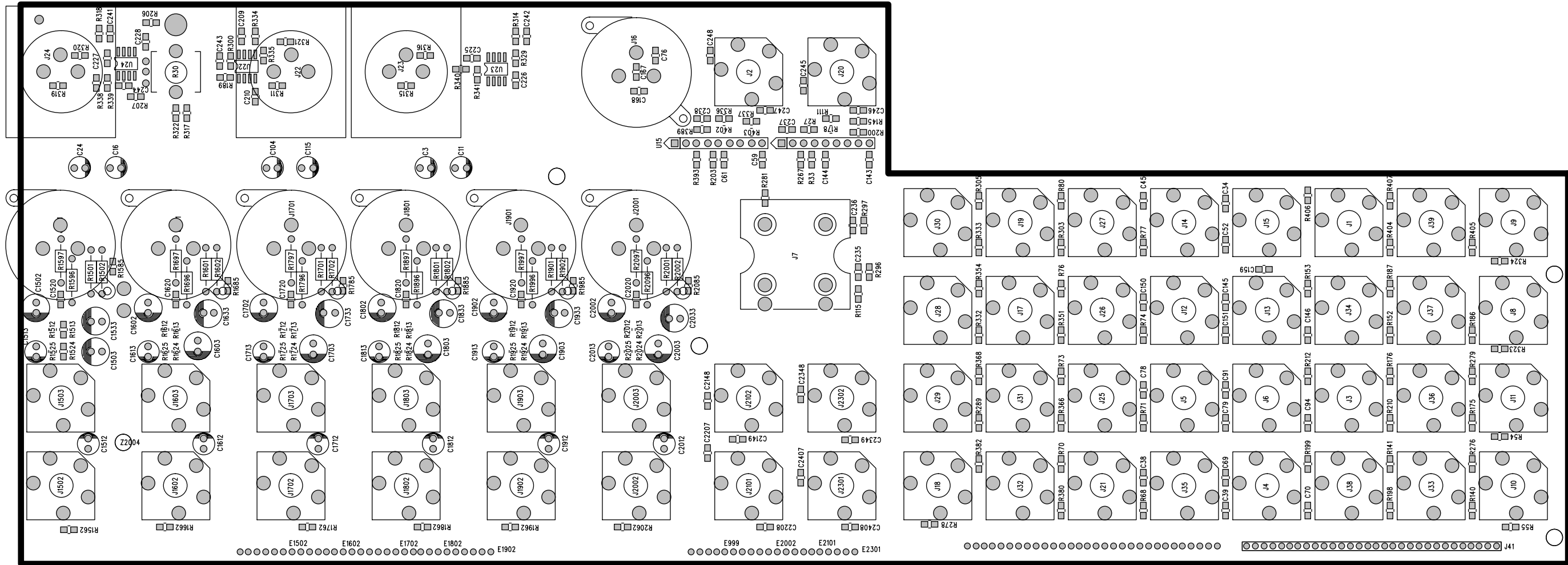

DWG. NO.	990-051-00	SHT	1	REV:	A	1
ECO#	REV:	DESCRIPTION	REV. BY:	APP. BY:	DATE	
	A	RELEASED TO PRODUCTION	TRH		8-10-94	

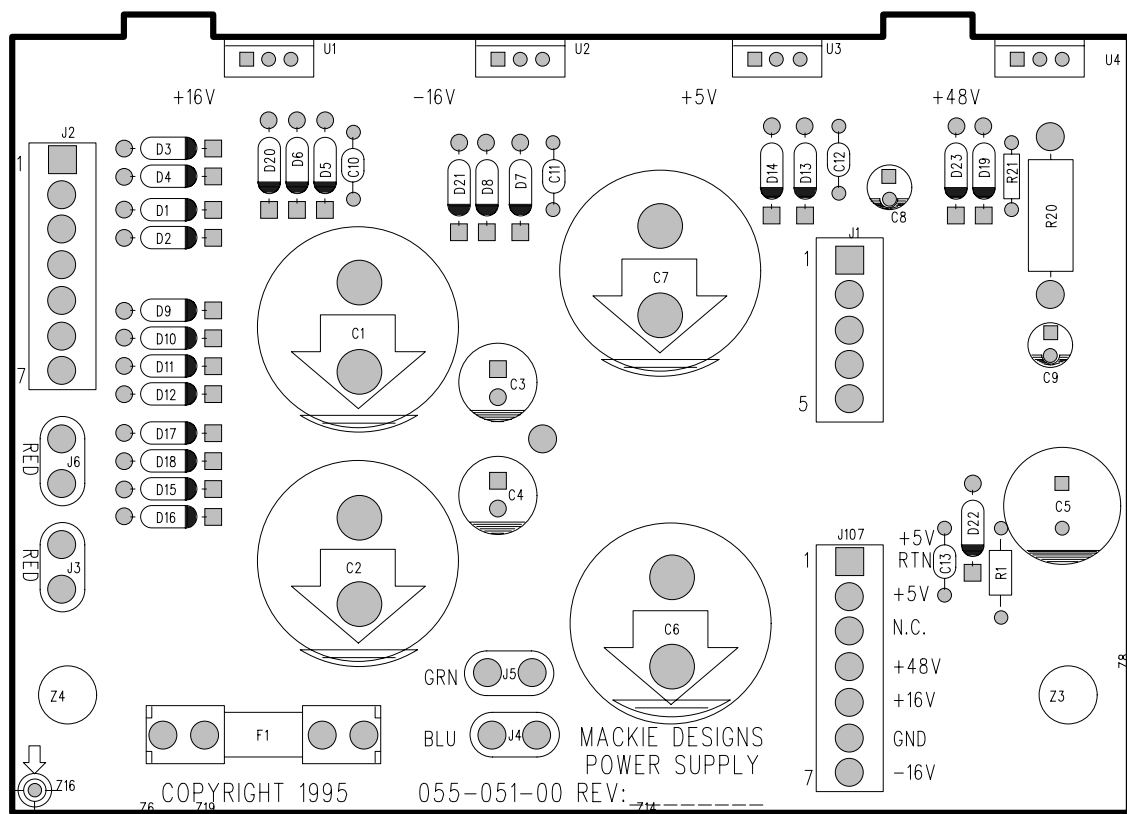
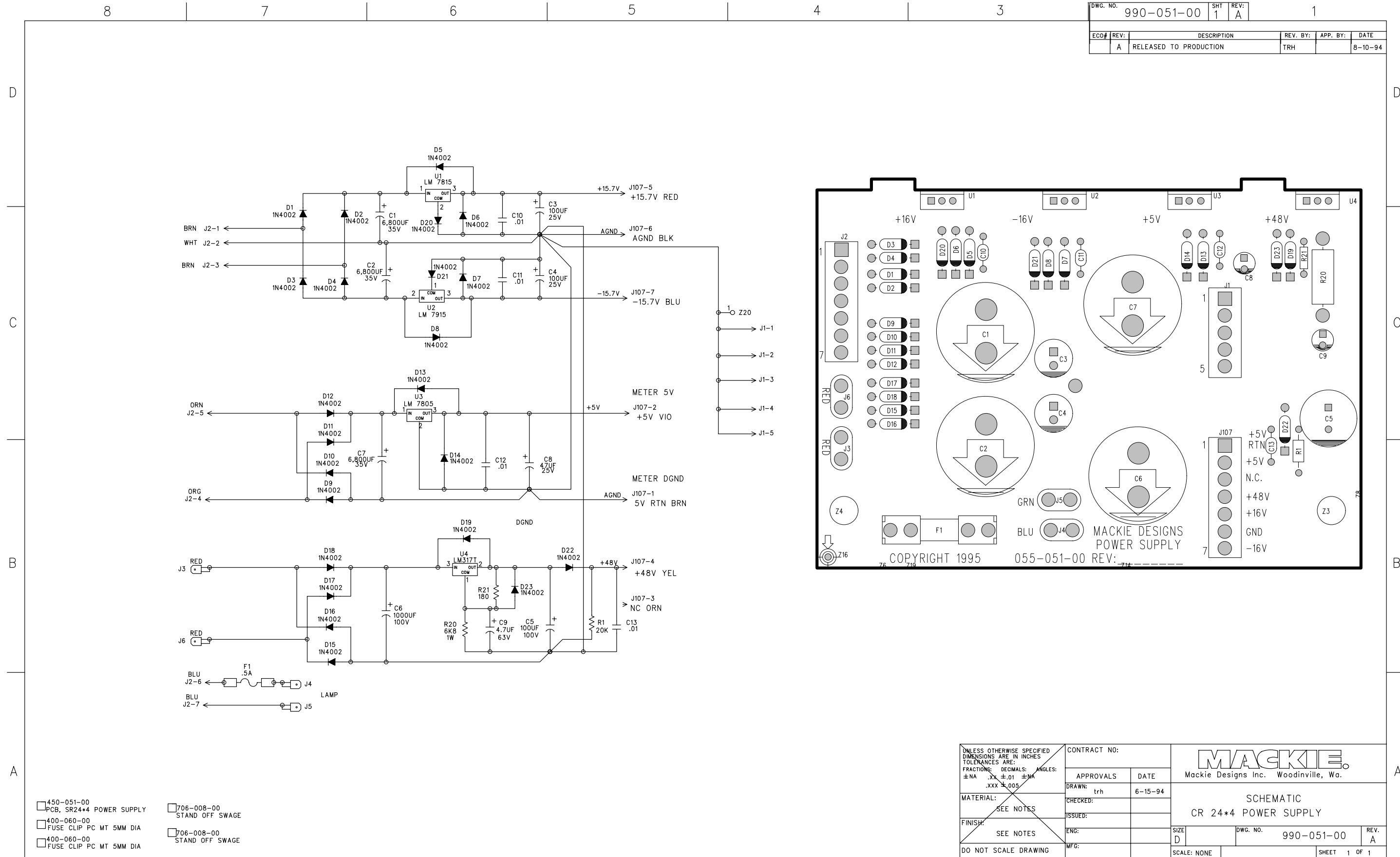

- 450-051-00 PCB, SR24•4 POWER SUPPLY
- 400-060-00 FUSE CLIP PC MT 5MM DIA
- 400-060-00 FUSE CLIP PC MT 5MM DIA
- 706-008-00 STAND OFF SWAGE
- 706-008-00 STAND OFF SWAGE

UNLESS OTHERWISE SPECIFIED DIMENSIONS ARE IN INCHES TOLERANCES ARE: FRACTIONS: DECIMALS: ANGLES: ±NA .XX ±.01 ±NA .XXX ±.005	CONTRACT NO:		MACKIE Mackie Designs Inc. Woodville, Wa.				
	APPROVALS	DATE					
	MATERIAL:	CHECKED:	trh	6-15-94			
	FINISH:	ISSUED:	ENG:				
DO NOT SCALE DRAWING	MFG:						
SCALE: NONE		SIZE	D	DWG. NO.	990-051-00	REV.	A
		SHEET		1 OF 1			

51-1 POWER SUPPLY 051 Rev A

DWG. NO.	990-050-00	SHT	14	REV.	S	1
ECO#	REV.	DESCRIPTION	REV. BY:	APP. BY:	DATE	

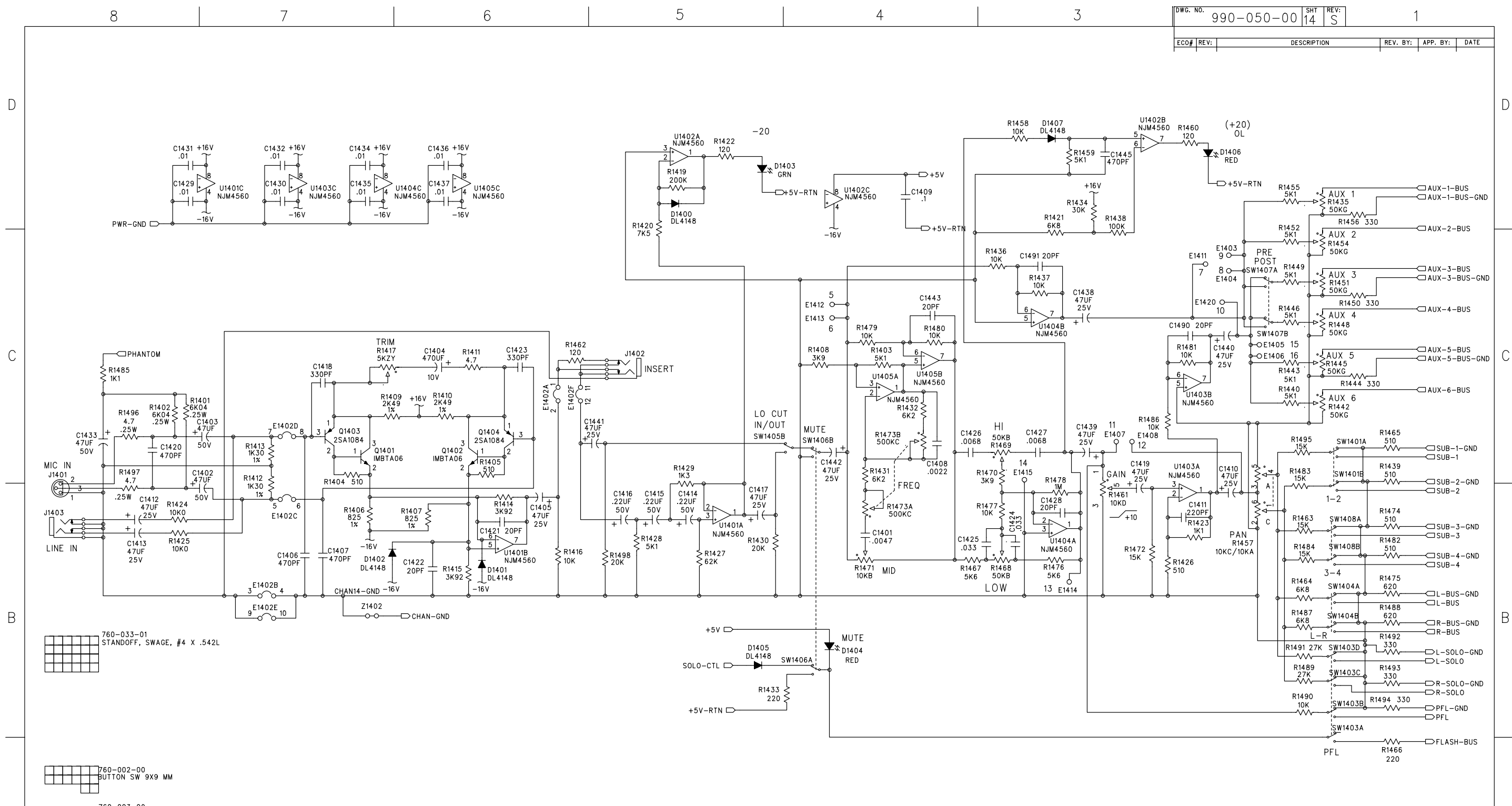

CHANNELS 1-20, CHANNEL 14 SHOWN

- 760-033-01
STANDOFF, SWAGE, #4 X .542L
- 760-002-00
BUTTON SW 9X9 MM
- 760-003-00
BUTTON SW 9X5 MM
- 760-013-00
BUTTON SW RECT 9X5
- 450-050-00
PCB, SLAVE-14 BOARD, 24*4
- 820-015-00
FLEXSTRIP JUMPER 30 COND 5"

UNLESS OTHERWISE SPECIFIED DIMENSIONS ARE IN INCHES TOLERANCES ARE: FRACTIONS: DECIMALS: ANGLES: ±.NA .XX ±.01 ±.MA .XXX ±.005	CONTRACT NO:		 Mackie Designs Inc. Woodinville, Wa.
	APPROVALS	DATE	
	DRAWN: trh	4-21-95	
	CHECKED:		
MATERIAL:	CHECKED:		SCHEMATIC, CHANNEL 14, SR 24-4
SEE NOTES	ISSUED:		
FINISH:	ENG:		
SEE NOTES	MFG:		
DO NOT SCALE DRAWING			DWG. NO. 990-050-00 REV. S SHEET 14 OF 14

See page 50-3 and 50-4 for the rest of this board

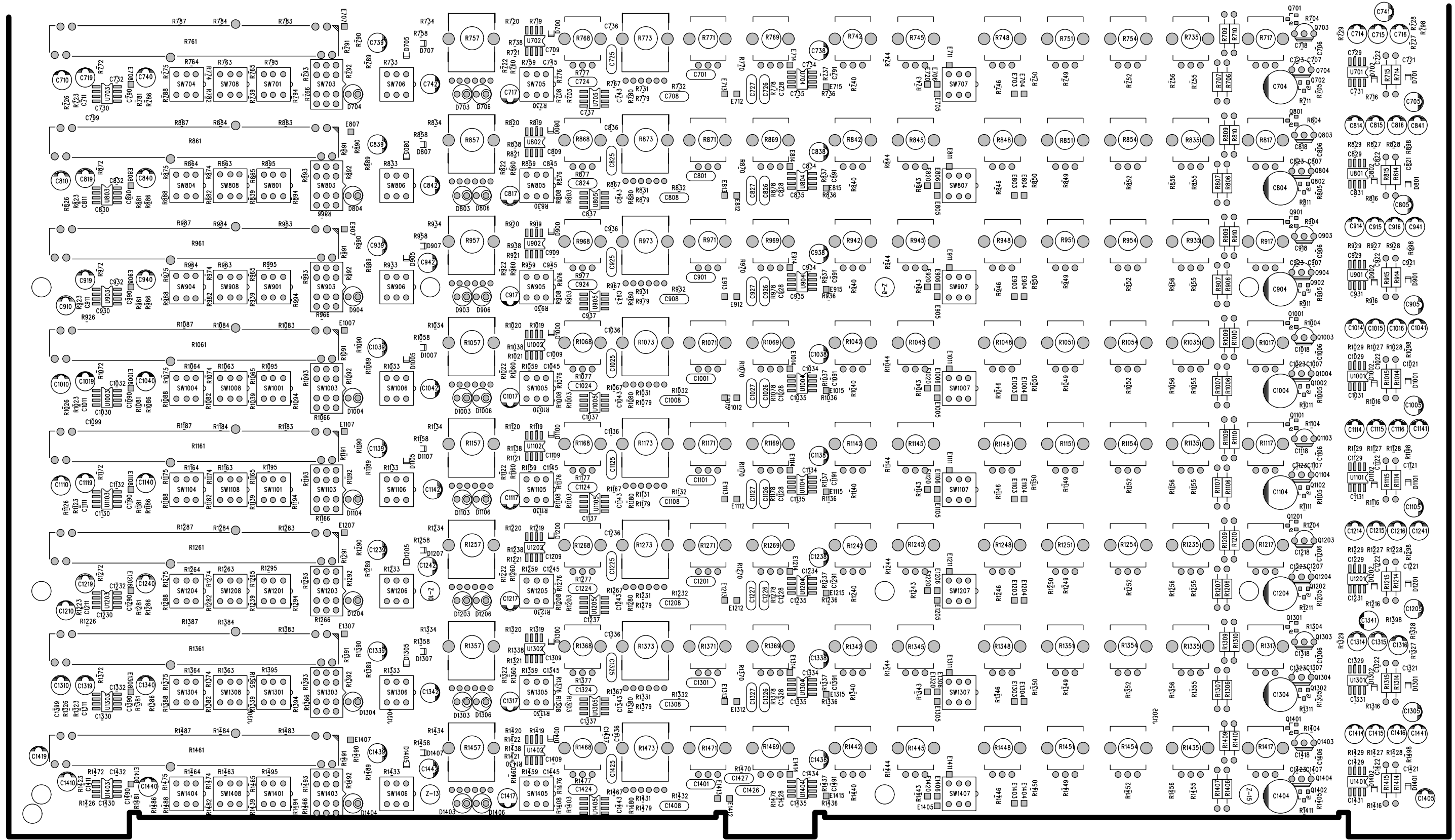

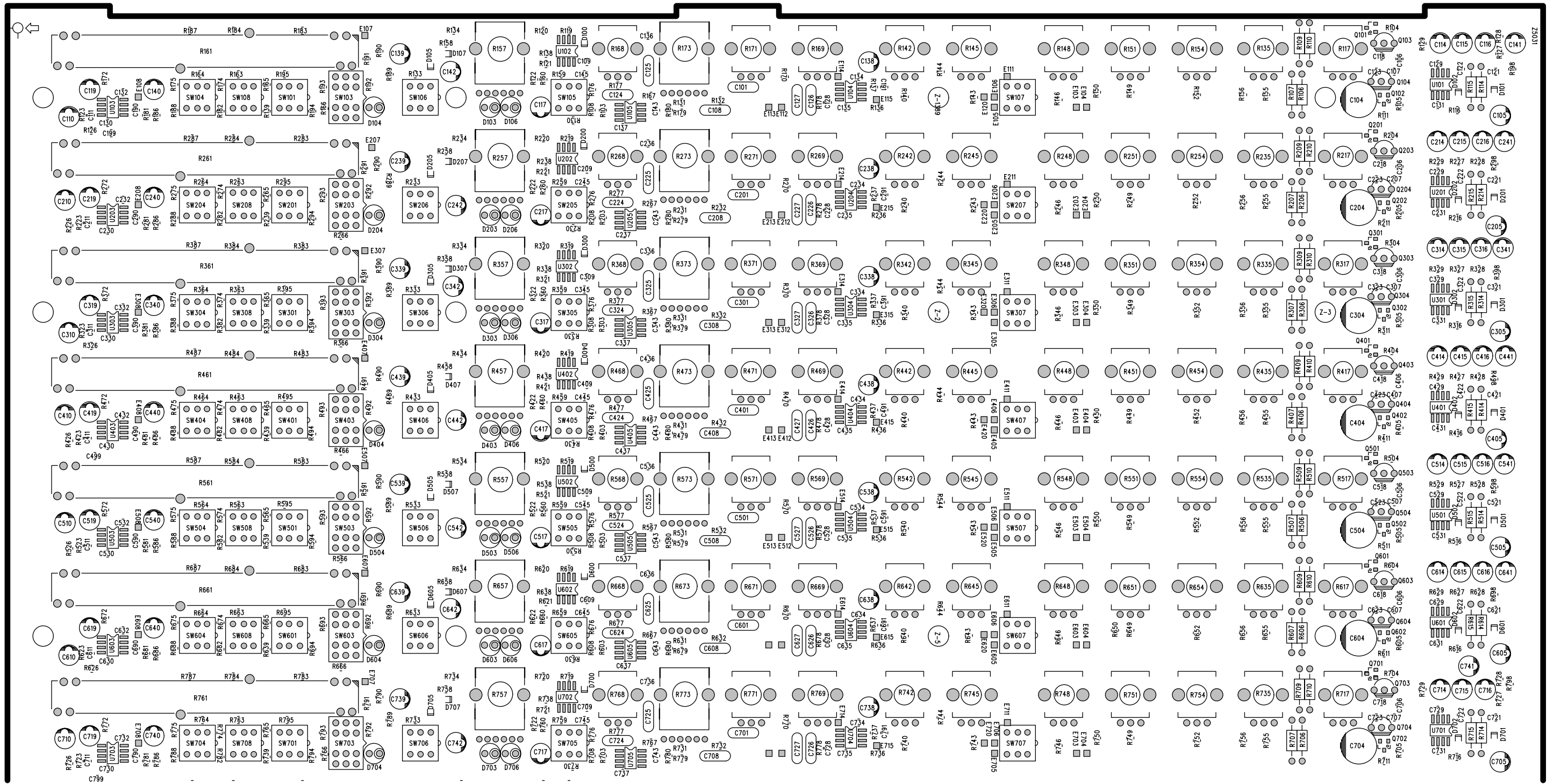

See page 50-2 and 50-4 for the rest of this board

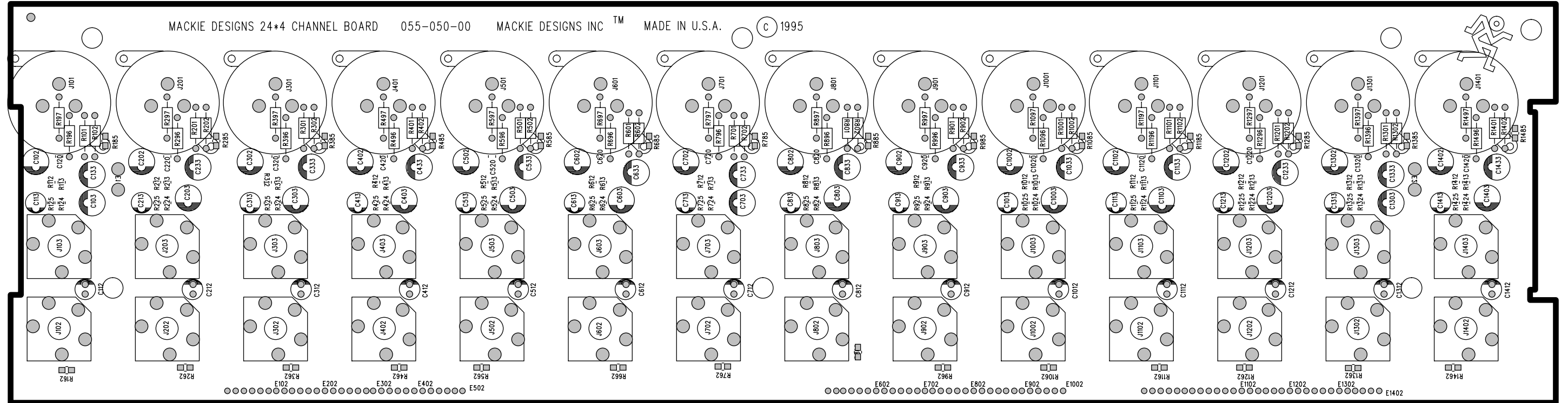

This board is a snap-off from the board on pages 50-2 and 50-3