

Technical Manual



JBL EON315

SPECIFICATIONS

ACOUSTIC & ELECTRICAL SPECIFICATIONS:

- System Power Rating: 280 W continuous, 560 W peak
- Frequency Response: 50 Hz – 18 kHz (± 3 dB) (EQ in "Flat" position)
- Frequency Range: 38 Hz – 20 kHz (-10 dB) (EQ in "Flat" position)
- LF Power Amp: 220 W continuous at driver impedance
- HF Power Amp: 60 W continuous at driver impedance
- Input Gain: Mic position: - Infinity to +40 dB
Line position: - Infinity to +4 dB (+20 dBu Max signal input)
- Input Impedance: 64 K ohms (balanced), 32 K (unbalanced)
- Boost EQ: LF +3 dB Shelving Filter @ 150 Hz
HF +2.5 dB Shelving Filter @ 4 kHz
- Low Cut Filter: Preset high pass @ 120 Hz
- Maximum SPL: 127 dB
- Crossover Frequency: 1.8 kHz

SYSTEM COMPONENTS:

- Baffle/Grille Assembly: 441956-001
- Low Frequency Transducer: M115-2 380 mm (15 in)
- DC Resistance: 1.4 ohm $\pm 10\%$

SYSTEM COMPONENTS: (CONT'D)

- High Frequency Transducer: 2414H-1 25.4 mm (1 in) polymer diaphragm, neodymium compression driver
- DC Resistance: 3.60 ohm $\pm 0.2\%$
- Input connector: Balanced XLR / 1/4 inch TRS combo jack
- Output Connector: Balanced male XLR, +20 dBu (peak)
- XLR Pin Assignments: Pin 2 (+), Pin 3 (-), Pin 1 (GND)

AURAL SWEEP TEST SPECIFICATIONS:

- A. System Aural Sweep Test: 200mV Input, 20 Hz to 20 kHz
Sweep Duration: 5 seconds
Volume Control Full Clockwise
- B. L.F. Aural Sweep Test: 3.5V Input, 20 Hz to 2 kHz
- C. H.F. Aural Sweep Test: .75V Input, 500 Hz to 1.5 kHz

PHYSICAL SPECIFICATIONS:

- Enclosure Dimensions: 685 x 438 x 366 mm D
(27 x 17.3 x 14.4 in D)
- Shipping Weight: 35 lb (15.9 kg.)

WARRANTY INFORMATION:

- Refer to Warranty Statement packed with each product.

PACKAGE

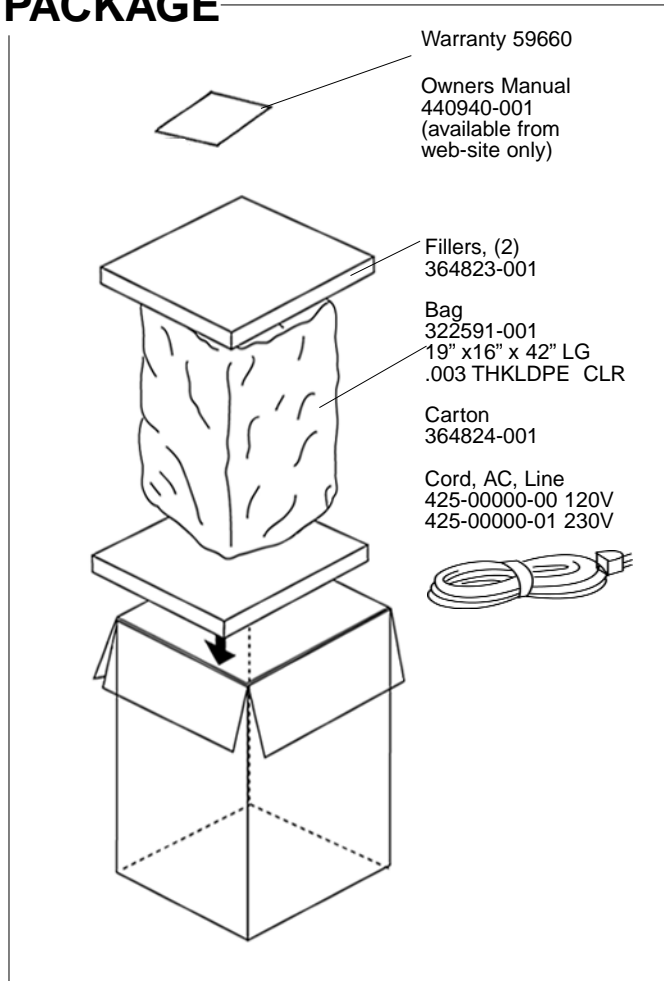

WIRING DIAGRAM

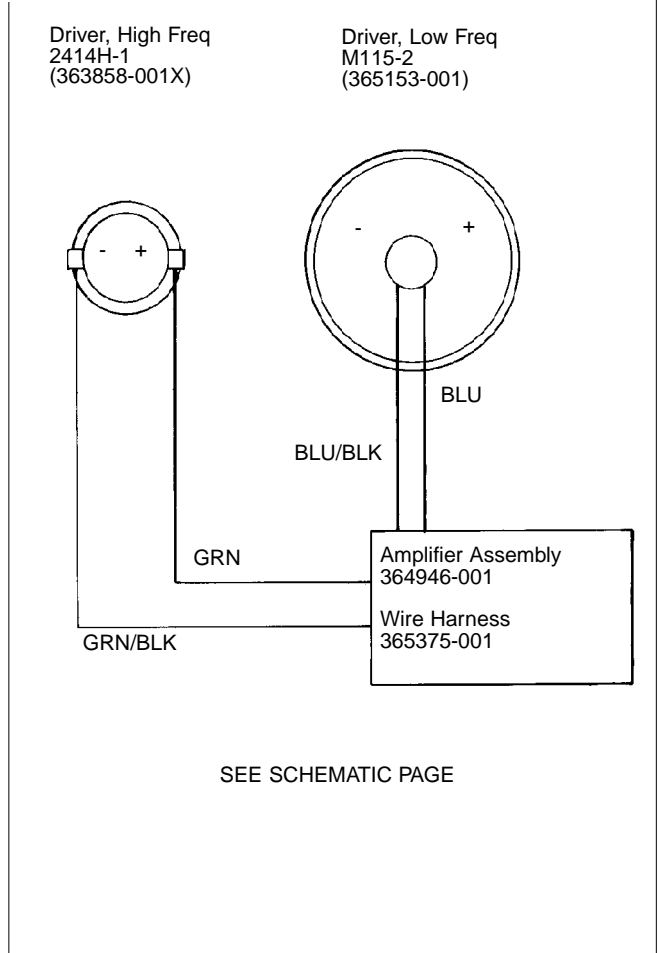

JBL EON315

SCHEMATIC (Wire Harness)

365375-001

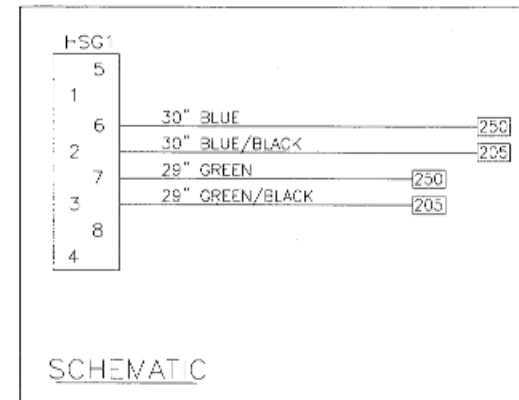
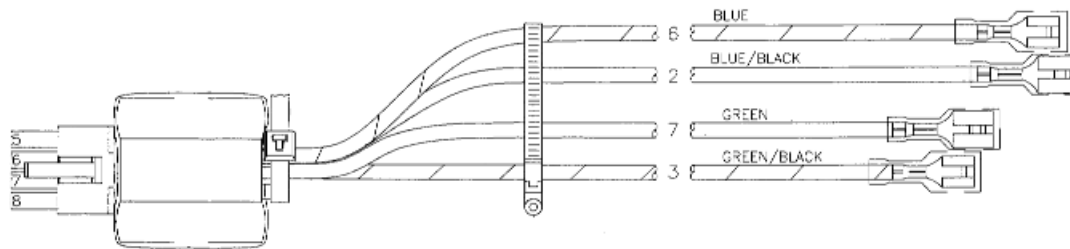
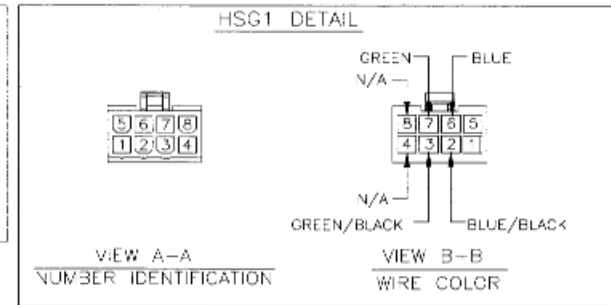
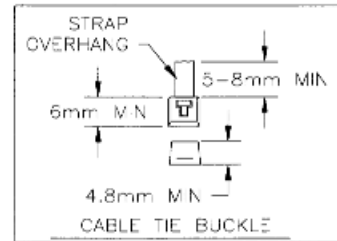

JBL EON315

COMPONENT EXPLODED VIEW

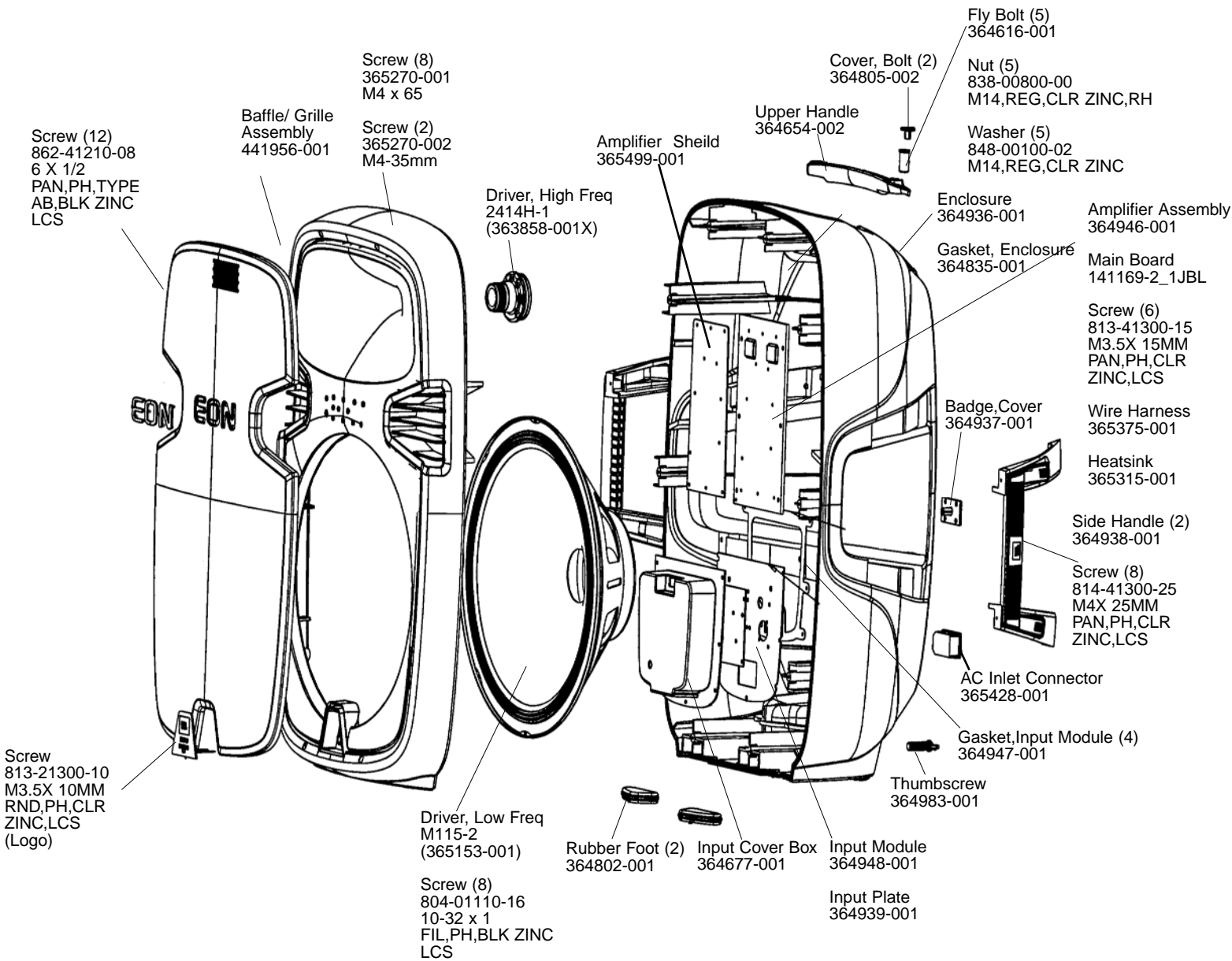

JBL EON315