

EXPORT WIRING

POWER XFMR
PART # 94-650-40

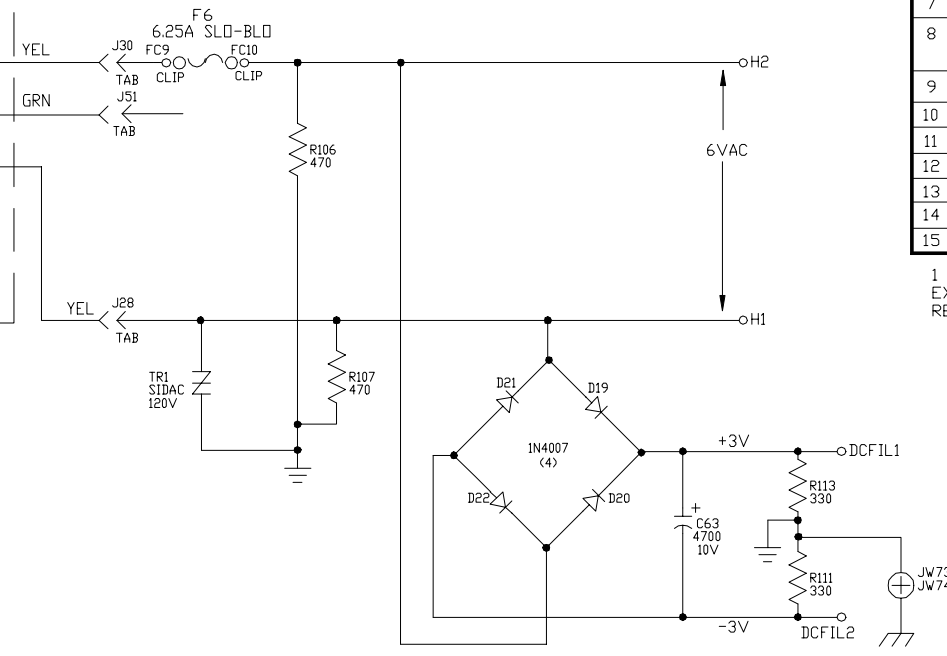
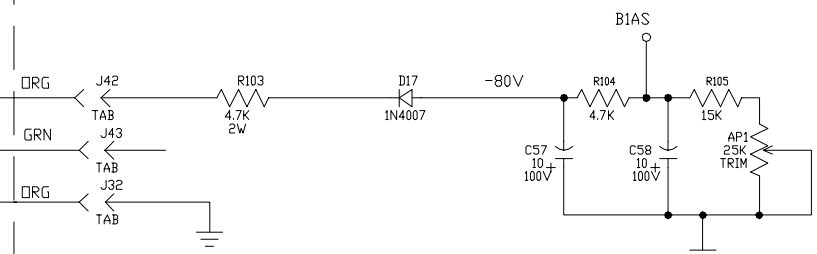
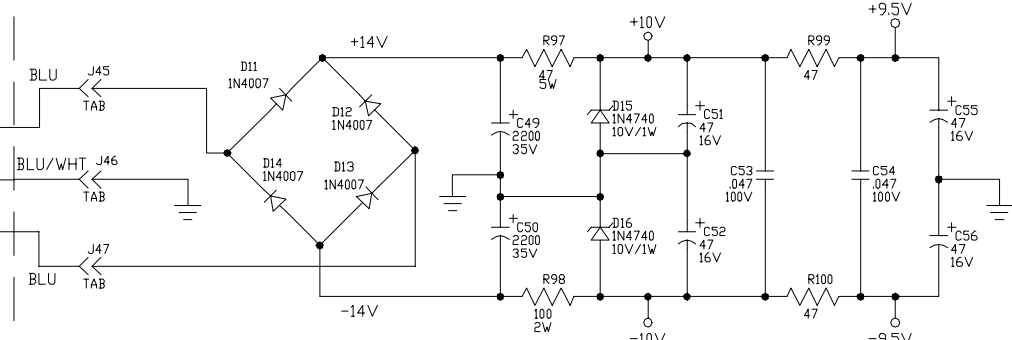

TEST POINT CHART

T.P. #	D.C. VOLTAGE NO SIGNAL (V)	SIGNAL, CHANNEL 1 ACTIVE (VP-P)	SIGNAL, CHANNEL 2 ACTIVE (VP-P)
1	205	0.3	0.3
2	215	0.02	0.02
3	215	0.03	2.2
4	185	---	0.14
5	200	---	105
6	215	---	130 (CLIPPED)
7	0	6	
8	0	2 W/.03VP-P SIGNAL FROM REV.	
9	0	0.6	
10	0	1.7	
11	265	22	15 (CLIPPED)
12	0	12	7.5 (CLIPPED)
13	---	0.2VDC	10VDC
14	---	10VDC	0.2VDC
15	---	0.2VDC (FX ON)	10VDC (FX OFF)

1 KHz SIGNAL @ INPUT; ALL CONTROLS @ "10", EXCEPT CHANNEL 2 GAIN, HIGH, MASTER @ "5" AND REVERB, PRESENCE @ "0". 8 OHM LOAD.

P/N 07-105-02
SUPERCEDES 07S295-51 !

- NOTES**
- CAUTION: SHOCK HAZARD!! THIS UNIT CONTAINS HAZARDOUS VOLTAGE. DISCONNECT POWER AND BE SURE POWER SUPPLY IS DISCHARGED BEFORE TOUCHING INTERNAL PARTS.
 - UNLESS NOTED, RESISTOR VALUES IN OHMS, 1/4W-5% TOL. CAPACITOR VALUES IN MICROFARADS, 50V-10% TOL.
 - VOLTAGES ARE MEASURED WITH 1 MEGOHM OSCILLOSCOPE AND 10 MEGOHM DIGITAL VOLTMETER.
 - CHASSIS GROUND \uparrow DIRTY GROUND \downarrow SIGNAL GROUND \pm

- BIAS CALIBRATION PROCEDURE**
- CONNECT UNIT TO PROPER AC LINE VOLTAGE.
 - ALLOW UNIT TO WARM UP AT LEAST 5 MINUTES.
 - WITH NO SIGNAL APPLIED ADJUST AP1 FOR 85 WATTS (0.8A DOMESTIC) DRAW FROM THE LINE.
 - ALTERNATE METHOD: WITH ENOUGH SIGNAL (CLEAN) TO JUST CLIP OUTPUT ADJUST AP1 FOR SLIGHT CROSSOVER DISTORTION VISIBLE ON OSCILLOSCOPE TRACE.

1	10/4/00	CHGD PARTS PER ECRN N00085	N00085	WFB	
0		CONTROL ISSUE			
INITIAL ISSUE					
REV:	DATE:	DESCRIPTION	ECR/ECN NO:	CHNG'D BY:	APPR'D BY:
THIS INFORMATION CONTAINED ON THIS DRAWING IS PROPRIETARY TO ST. LOUIS MUSIC, INC.					
SIGNATURES:		DATE:			
DRAWN: REM		2/19/99			
CHK'D:				FIRST USED ON:	
RLSD:				BV120HBb	
TOLERANCES:		DRAWING SIZE: D		DRAWING TITLE:	
		SCHEMATIC		SCHEMATIC - GUITAR AMP	
		CLASS CODE:		DRAWING NO.:	
		SCALE: NONE		07S105-XX	
		SHEET: 1 of 6			

11880 Borman Dr.
St. Louis, Missouri
63146

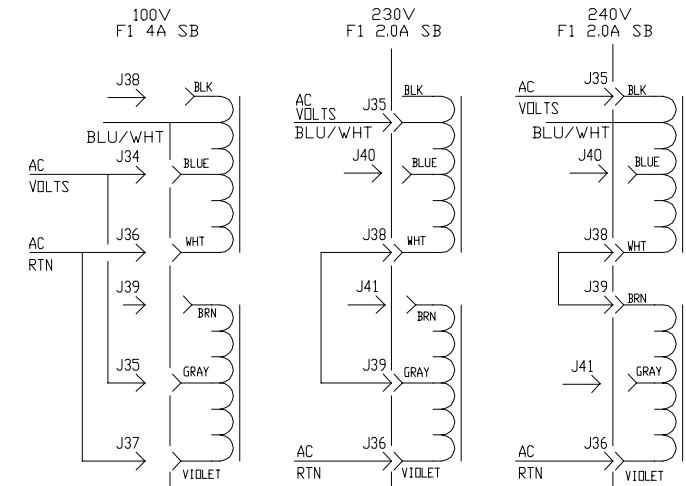
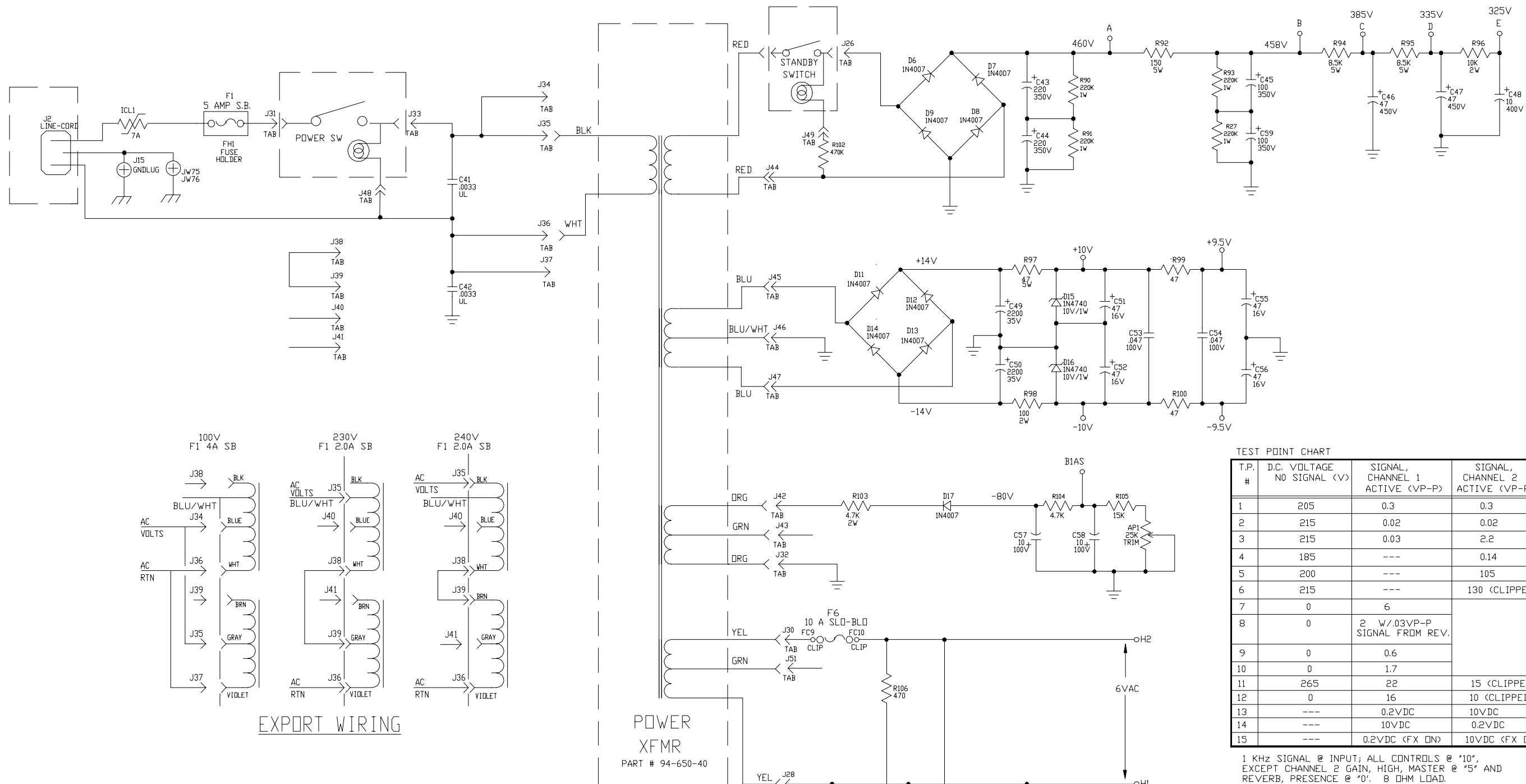

TEST POINT CHART

T.P. #	D.C. VOLTAGE NO SIGNAL (V)	SIGNAL, CHANNEL 1 ACTIVE (VP-P)	SIGNAL, CHANNEL 2 ACTIVE (VP-P)
1	205	0.3	0.3
2	215	0.02	0.02
3	215	0.03	2.2
4	185	---	0.14
5	200	---	105
6	215	---	130 (CLIPPED)
7	0	6	
8	0	2 W/.03VP-P SIGNAL FROM REV.	
9	0	0.6	
10	0	1.7	
11	265	22	15 (CLIPPED)
12	0	16	10 (CLIPPED)
13	---	0.2VDC	10VDC
14	---	10VDC	0.2VDC
15	---	0.2VDC (FX ON)	10VDC (FX OFF)

1 KHz SIGNAL @ INPUT; ALL CONTROLS @ '10', EXCEPT CHANNEL 2 GAIN, HIGH, MASTER @ '5' AND REVERB, PRESENCE @ '0'. 8 OHM LOAD.

- NOTES**
- 1) CAUTION: SHOCK HAZARD! THIS UNIT CONTAINS HAZARDOUS VOLTAGE. DISCONNECT POWER AND BE SURE POWER SUPPLY IS DISCHARGED BEFORE TOUCHING INTERNAL PARTS.
 - 2) UNLESS NOTED, RESISTOR VALUES IN OHMS, 1/4W-5% TOL. CAPACITOR VALUES IN MICROFARADS, 50V-10% TOL.
 - 3) VOLTAGES ARE MEASURED WITH 1 MEGOHM OSCILLOSCOPE AND 10 MEGOHM DIGITAL VOLTMETER.
 - 4) CHASSIS GROUND \uparrow DIRTY GROUND ∇ SIGNAL GROUND \oplus

- BIAS CALIBRATION PROCEDURE**
- 1) CONNECT UNIT TO PROPER AC LINE VOLTAGE.
 - 2) ALLOW UNIT TO WARM UP AT LEAST 5 MINUTES.
 - 3) WITH NO SIGNAL APPLIED ADJUST AP1 FOR 120 WATTS (1.3A DOMESTIC) DRAW FROM THE LINE.
 - 4) ALTERNATE METHOD: WITH ENOUGH SIGNAL (CLEAN) TO JUST CLIP OUTPUT ADJUST AP1 FOR SLIGHT CROSSOVER DISTORTION VISIBLE ON OSCILLOSCOPE TRACE.

P/N 07-105-01
SUPERCEDES 07S295-01 I

0	SEE SHT 1 FOR REV HISTORY				
REV:	DATE:	DESCRIPTION	ECR/ECN NO:	CHNG'D BY:	APPR'D BY:
THIS INFORMATION CONTAINED ON THIS DRAWING IS PROPRIETARY TO ST. LOUIS MUSIC, INC.					
SIGNATURES:		DATE:	11880 Borman Dr. St. Louis, Missouri 63146		
DRAWN: REM		2/19/99	FIRST USED ON: BV120HBb		
CHK'D:		DRAWING TITLE: SCHEMATIC - GUITAR AMP			
RLS'D:		DRAWING NO.:			
TOLERANCES:		DRAWING SIZE: D	DRAWING NO.:		
		DRAWING TYPE: SCHEMATIC	07S105-XX		
		CLASS CODE:	DRAWING NO.:		
		SCALE: NONE	SHEET: 2 of 6		

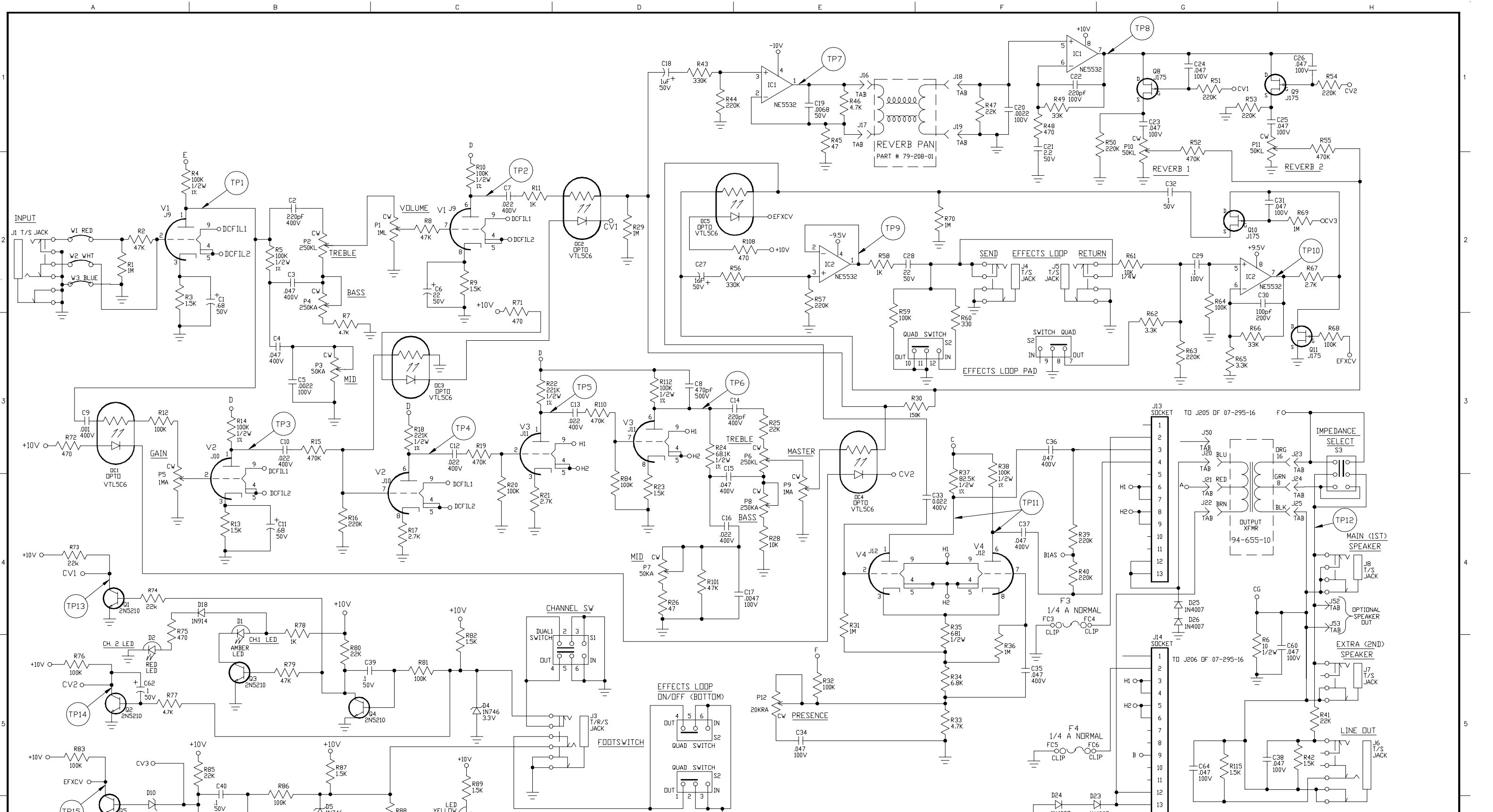

P/N 07-105-02
SUPERCEDES 07S295-51 !

REV:	DATE:	DESCRIPTION:	ECR/ECN NO.:	CHNG'D BY:	APPR'D BY:	DATE:
SEE SHIT 1 FOR REV HISTORY						
THIS INFORMATION CONTAINED ON THIS DRAWING IS PROPRIETARY TO ST. LOUIS MUSIC, INC.						
SIGNATURES:		DATE:		11880 Borman Dr. St. Louis, Missouri 63146		
DRAWN: REM		2/19/99		St. Louis Music, Inc.		
CHK'D:				FIRST USED ON: BV120HBb		
RLS'D:				DRAWING TITLE: SCHEMATIC - GUITAR AMP		
DRAWING NO.:				DRAWING NO.:		
TOLERANCES:		DRAWING SIZE: D		DRAWING NO.:		
		DRAWING TYPE: SCHEMATIC		DRAWING NO.:		
		CLASS CODE:		DRAWING NO.:		
		SCALE: NONE		DRAWING NO.:		
		SHEET: 3 OF 6		DRAWING NO.:		
				DRAWING NO.:		

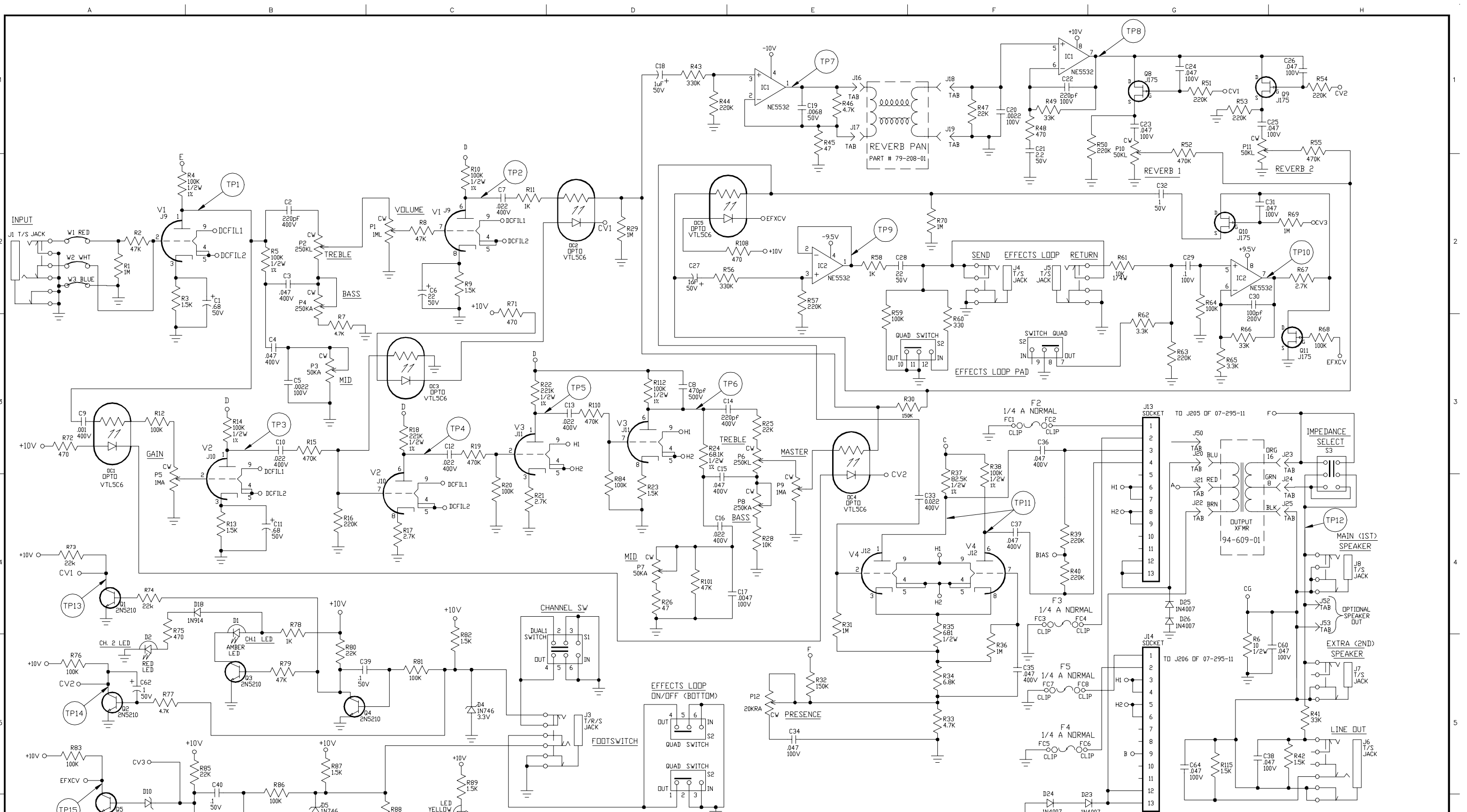

P/N 07-105-01
SUPERCEDES 07S295-01 I

REV:	DATE:	DESCRIPTION	ECR/ECN NO:	CHNG'D BY:	APPR'D BY:	DATE:
THIS INFORMATION CONTAINED ON THIS DRAWING IS PROPRIETARY TO ST. LOUIS MUSIC, INC.						
SIGNATURES:		DATE:		11880 Borman Dr. St. Louis, Missouri 63146		
DRAWN: REM		2/19/99		FIRST USED ON: BV120HBb		
CHK'D:				DRAWING TITLE: SCHEMATIC - GUITAR AMP		
RLS'D:				DRAWING NO.:		
TOLERANCES:		DRAWING SIZE: D		DRAWING NO.:		
		DRAWING TYPE: SCHEMATIC		DRAWING NO.:		
		CLASS CODE:		DRAWING NO.:		
		SCALE: NONE		DRAWING NO.:		
		SHEET: 4 OF 6		DRAWING NO.:		
				DRAWING NO.:		

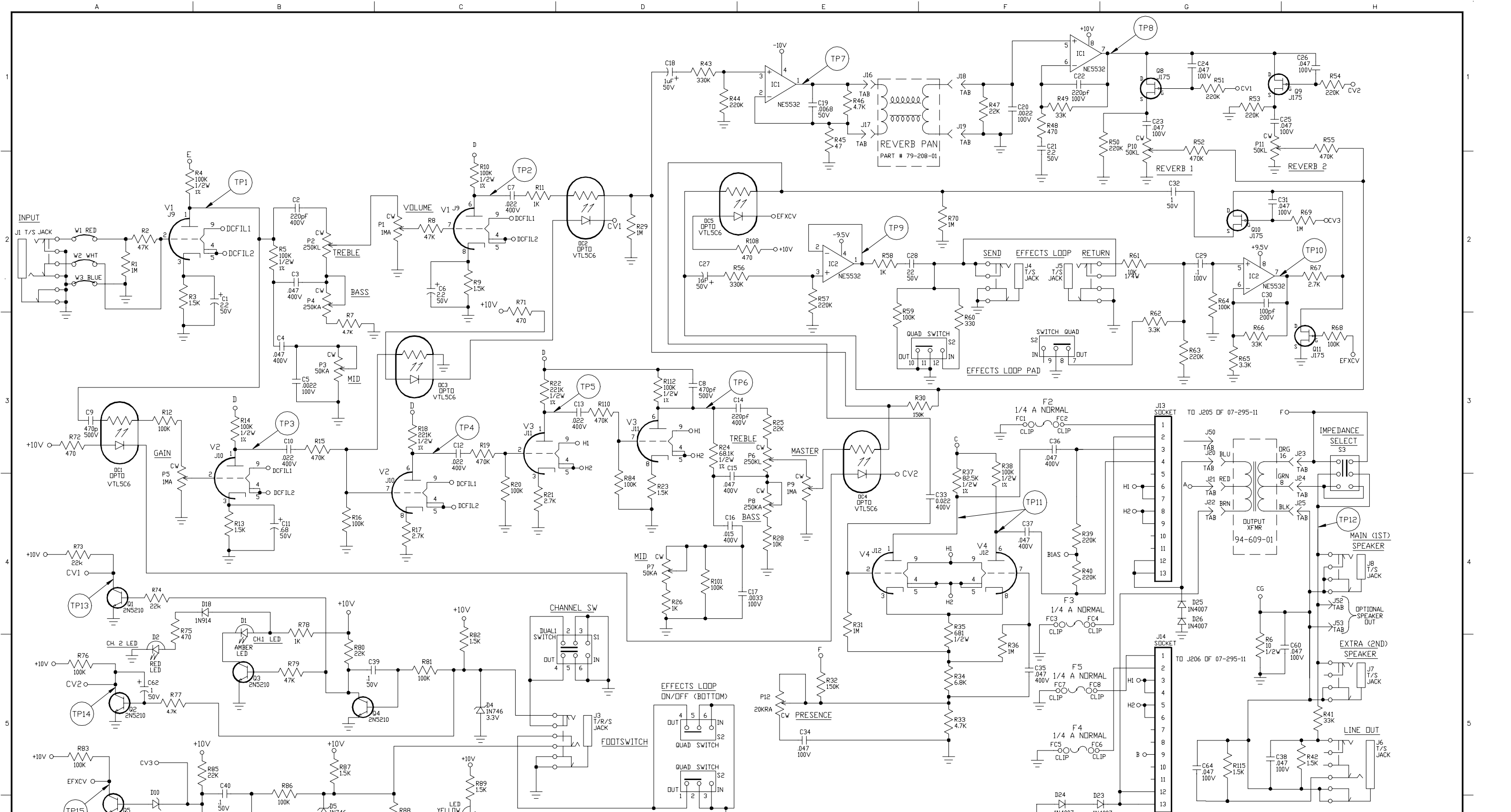

P/N 07-105-03
SUPERCEDES 07S295-02 !

REV:	DATE:	DESCRIPTION	ECR/ECN NO:	CHNG'D BY:	APPR'D BY:	DATE:
THIS INFORMATION CONTAINED ON THIS DRAWING IS PROPRIETARY TO ST. LOUIS MUSIC, INC.						
SIGNATURES:		DATE:				
DRAWN: REM		2/19/99				
CHK'D:				FIRST USED ON: BV120Hb6		
RLS'D:				DRAWING TITLE: SCHEMATIC - GUITAR AMP		
DRAWING SIZE: D		DRAWING NO.:				
DRAWING TYPE: SCHEMATIC						
CLASS CODE:						
SCALE: NONE		SHEET: 5 OF 6				

11880 Borman Dr.
St. Louis, Missouri
63146

DRAWING NO.: 07S105-XX

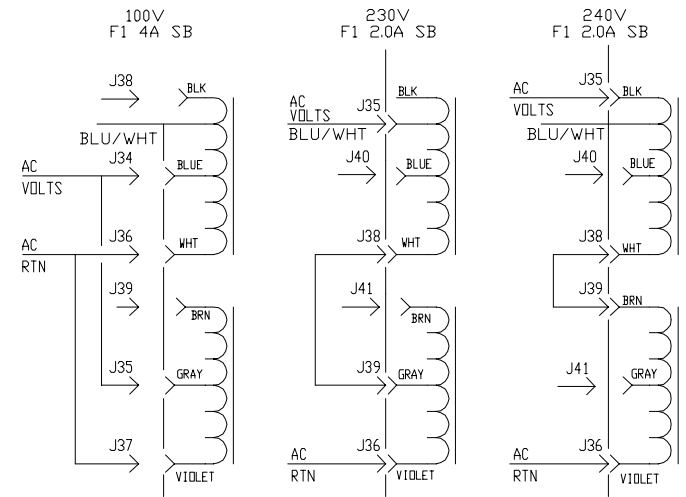
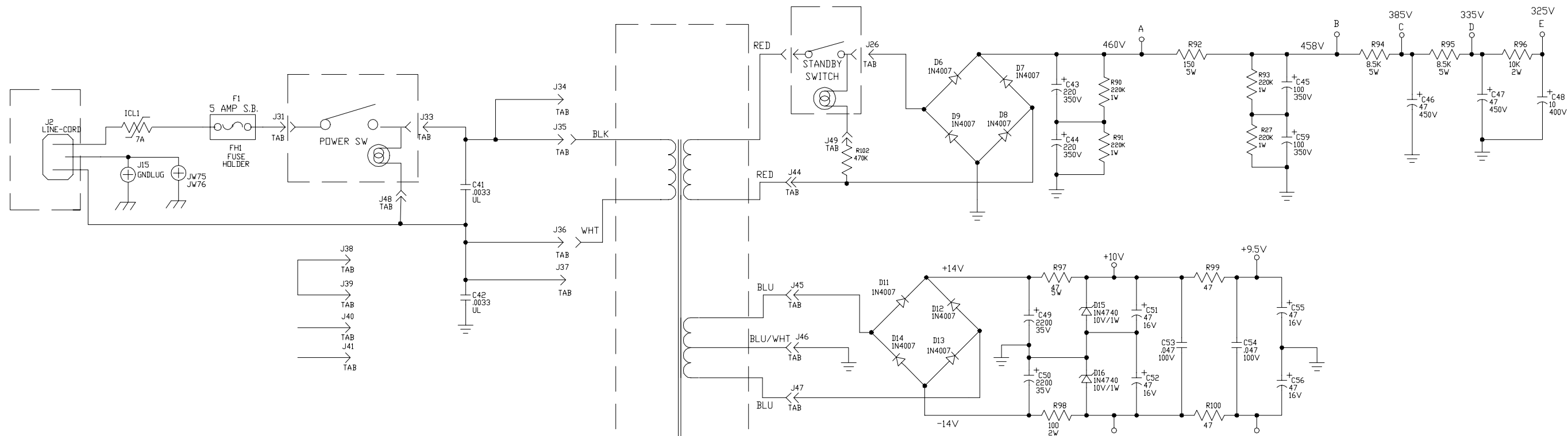

EXPORT WIRING

POWER XFMR
PART # 94-650-40

TEST POINT CHART

T.P. #	D.C. VOLTAGE NO SIGNAL (V)	SIGNAL, CHANNEL 1 ACTIVE (VP-P)	SIGNAL, CHANNEL 2 ACTIVE (VP-P)
1	205	0.3	0.3
2	215	0.02	0.02
3	215	0.03	2.2
4	185	---	0.07
5	200	---	50
6	215	---	130 (CLIPPED)
7	0	6	
8	0	2 W/0.3VP-P SIGNAL FROM REV.	
9	0	0.6	
10	0	1.7	
11	265	22	15 (CLIPPED)
12	0	16	10 (CLIPPED)
13	---	0.2VDC	10VDC
14	---	10VDC	0.2VDC
15	---	0.2VDC (FX ON)	10VDC (FX OFF)

1 KHz SIGNAL @ INPUT; ALL CONTROLS @ '10', EXCEPT CHANNEL 2 GAIN, HIGH, MASTER @ '5' AND REVERB, PRESENCE @ '0'. 8 OHM LOAD.

P/N 07-105-03
SUPERCEDES 07S295-02 I

- NOTES
- 1) CAUTION: SHOCK HAZARD!! THIS UNIT CONTAINS HAZARDOUS VOLTAGE. DISCONNECT POWER AND BE SURE POWER SUPPLY IS DISCHARGED BEFORE TOUCHING INTERNAL PARTS.
 - 2) UNLESS NOTED, RESISTOR VALUES IN OHMS, 1/4W-5% TOL. CAPACITOR VALUES IN MICROFARADS, 50V-10% TOL.
 - 3) VOLTAGES ARE MEASURED WITH 1 MEGOHM OSCILLOSCOPE AND 10 MEGOHM DIGITAL VOLTMETER.
 - 4) CHASSIS GROUND ⚡ DIRTY GROUND ⚡ SIGNAL GROUND ⚡

- BIAS CALIBRATION PROCEDURE
- 1) CONNECT UNIT TO PROPER AC LINE VOLTAGE.
 - 2) ALLOW UNIT TO WARM UP AT LEAST 5 MINUTES.
 - 3) WITH NO SIGNAL APPLIED ADJUST AP1 FOR 120 WATTS (1.3A DOMESTIC) DRAW FROM THE LINE.
 - 4) ALTERNATE METHOD: WITH ENOUGH SIGNAL (CLEAN) TO JUST CLIP OUTPUT ADJUST AP1 FOR SLIGHT CROSSOVER DISTORTION VISIBLE ON OSCILLOSCOPE TRACE.

0	SEE SHT 1 FOR REV HISTORY				
REV:	DATE:	DESCRIPTION	ECR/ECN NO:	CHNG'D BY:	APPR'D BY:
THIS INFORMATION CONTAINED ON THIS DRAWING IS PROPRIETARY TO ST. LOUIS MUSIC, INC.					
SIGNATURES:		DATE:		11880 Borman Dr. St. Louis, Missouri 63146	
DRAWN: REM		2/19/99		FIRST USED ON: BV120HBb	
CHK'D:				DRAWING TITLE: SCHEMATIC - GUITAR AMP	
RLS'D:				DRAWING NO.: 07S105-XX	
TOLERANCES:		DRAWING SIZE: D		SCALE: NONE	
		SHEET: 6 of 6			

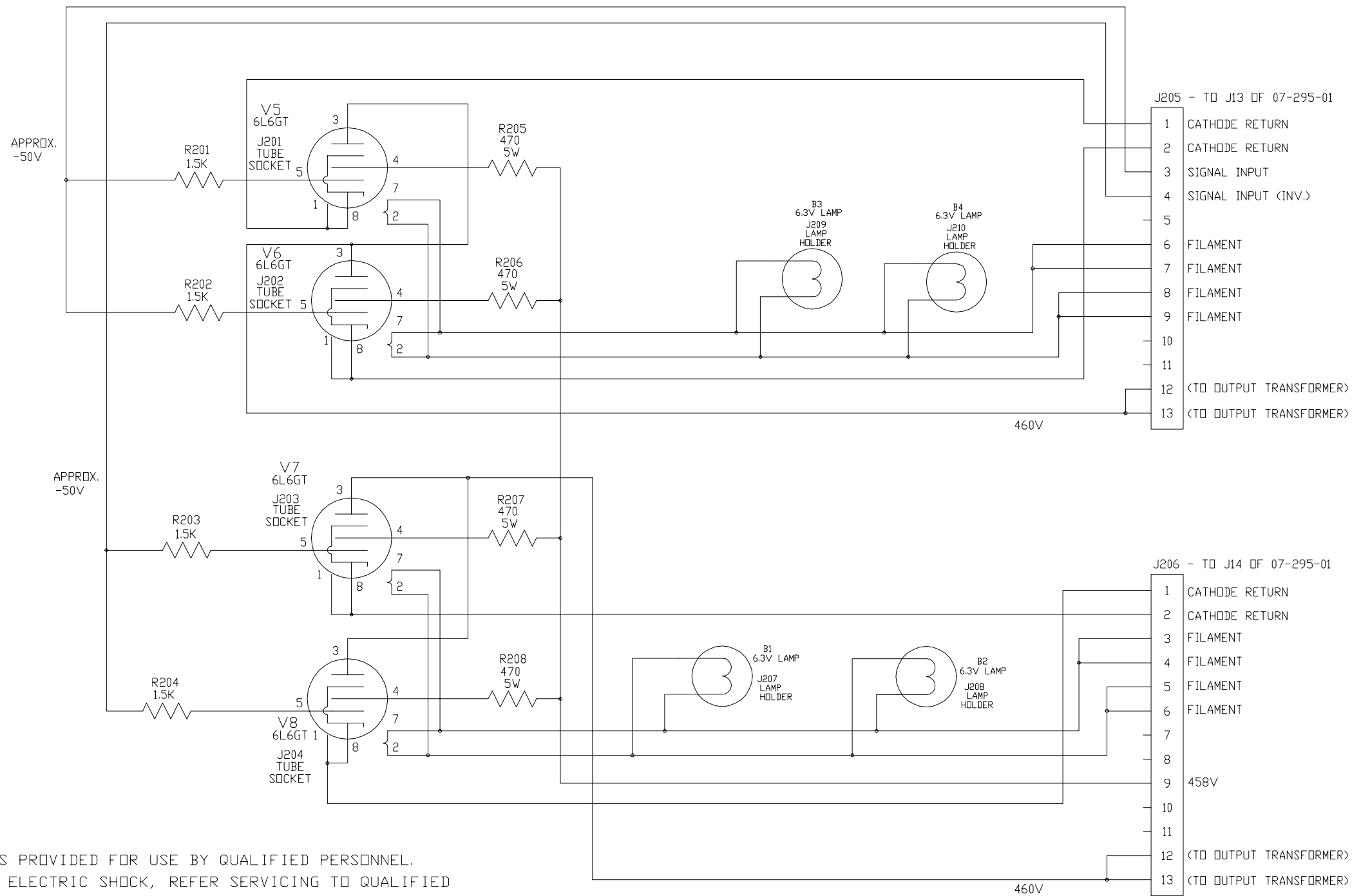

CAUTION:

THIS SCHEMATIC IS PROVIDED FOR USE BY QUALIFIED PERSONNEL. TO AVOID RISK OF ELECTRIC SHOCK, REFER SERVICING TO QUALIFIED SERVICE PERSONNEL. DO NOT PERFORM ANY SERVICING BEYOND THAT EXPLAINED IN THE OPERATING INSTRUCTIONS.

NOTES

- 1) CAUTION: SHOCK HAZARD!!
THIS UNIT CONTAINS HAZARDOUS VOLTAGE. DISCONNECT POWER AND BE SURE POWER SUPPLY IS DISCHARGED BEFORE TOUCHING INTERNAL PARTS.
- 2) UNLESS NOTED, RESISTOR VALUES IN OHMS, 1/4W-5% TOL. CAPACITOR VALUES IN MICROFARADS, 50V-10% TOL.
- 3) VOLTAGES ARE MEASURED WITH 1 MEGOHM OSCILLOSCOPE AND 10 MEGOHM DIGITAL VOLTMETER.
- 4) CHASSIS GROUND ---

SIGNATURES:		DATE:	 11880 BORMAN DR. ST. LOUIS, MISSOURI 63146
DRAWN:	LMA	04/03/96	
CHK'D:	GM	04/04/96	PROJECT NAME:
APP'D:	GM	04/04/96	BV-120H
ORIGINAL ISSUED:	04/04/96	DRAWING NAME:	
PLOT DATE:	04/03/96	TUBE BD. SCHEMATIC	
PLOT TIME:	23:06:38	DRAWING NO.	07S295-12
FILE NAME:	29512HO_	SCALE:	1:1
		SHEET:	-