

PA(NA0277I)



- NOTES:
1. ALL RESISTORS IN OHMS 1/4WATT UNLESS OTHERWISE NOTED.
 2. ALL CAPACITORS IN MFD. UNLESS OTHERWISE NOTED.
 3. ALL VOLTAGES MEASURED WITH A 10MΩ/DC ELECTRONIC VOLT METER, WITH ALL CONTROLS SET AT MINIMUM.
 4. TRANSISTORS
TR1, 3, 5: 2SC644
TR2, 4, 6: 2SC828
 5. RELAYS
SR-1: FUJITSU #474
SR-2: OMRON MH2/1Y
 6. TREMOLO TRANSFORMER
U.S. & CANADIAN MODELS: NOT PROVIDED
GENERAL, EUROPEAN, SOUTH AFRICAN & AUSTRALIAN MODELS: REFER TO PAGE 7
 7. AC OUTLET
PROVIDED ON GENERAL MODEL ONLY
 8. POWER SWITCH CIRCUIT
EUROPEAN & AUSTRALIAN MODELS: REFER TO PAGE 7
U.S. & CANADIAN MODELS: REFER TO PAGE 11

Yamaha Combo Amplifier
 Model RA-100
 Yamaha Europa G.m.b.H.
 GSB-019 10.12.75

POWER AMP SCHEMATIC DIAGRAM

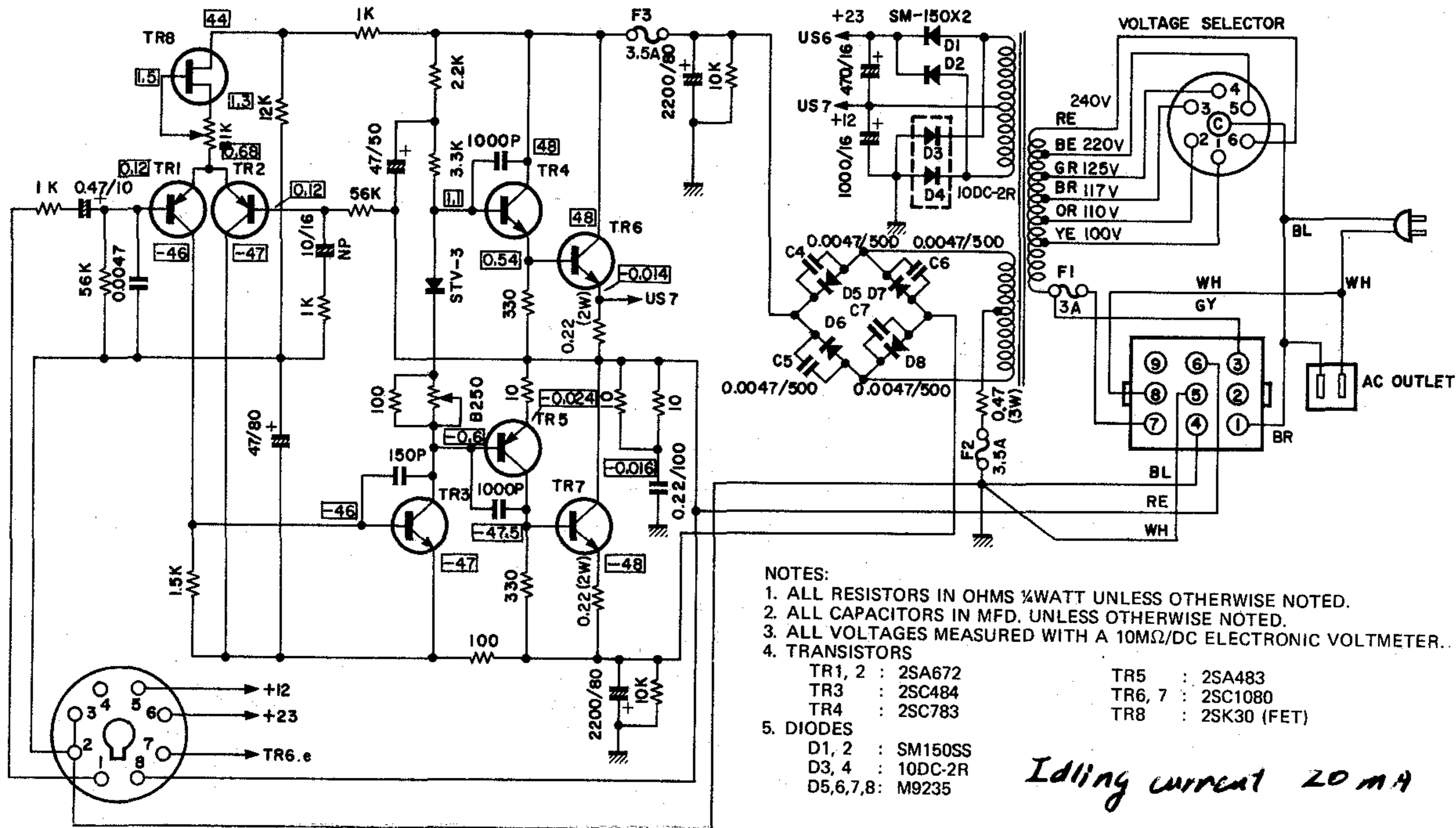

- NOTES:
1. ALL RESISTORS IN OHMS 1/4WATT UNLESS OTHERWISE NOTED.
 2. ALL CAPACITORS IN MFD. UNLESS OTHERWISE NOTED.
 3. ALL VOLTAGES MEASURED WITH A 10MΩ/DC ELECTRONIC VOLTMETER.
 4. TRANSISTORS

TR1, 2 : 2SA672	TR5 : 2SA483
TR3 : 2SC484	TR6, 7 : 2SC1080
TR4 : 2SC783	TR8 : 2SK30 (FET)
 5. DIODES

D1, 2 : SM150SS
D3, 4 : 10DC-2R
D5, 6, 7, 8 : M9235

Idling current 20 mA

▼ U.S. & CANADIAN MODELS

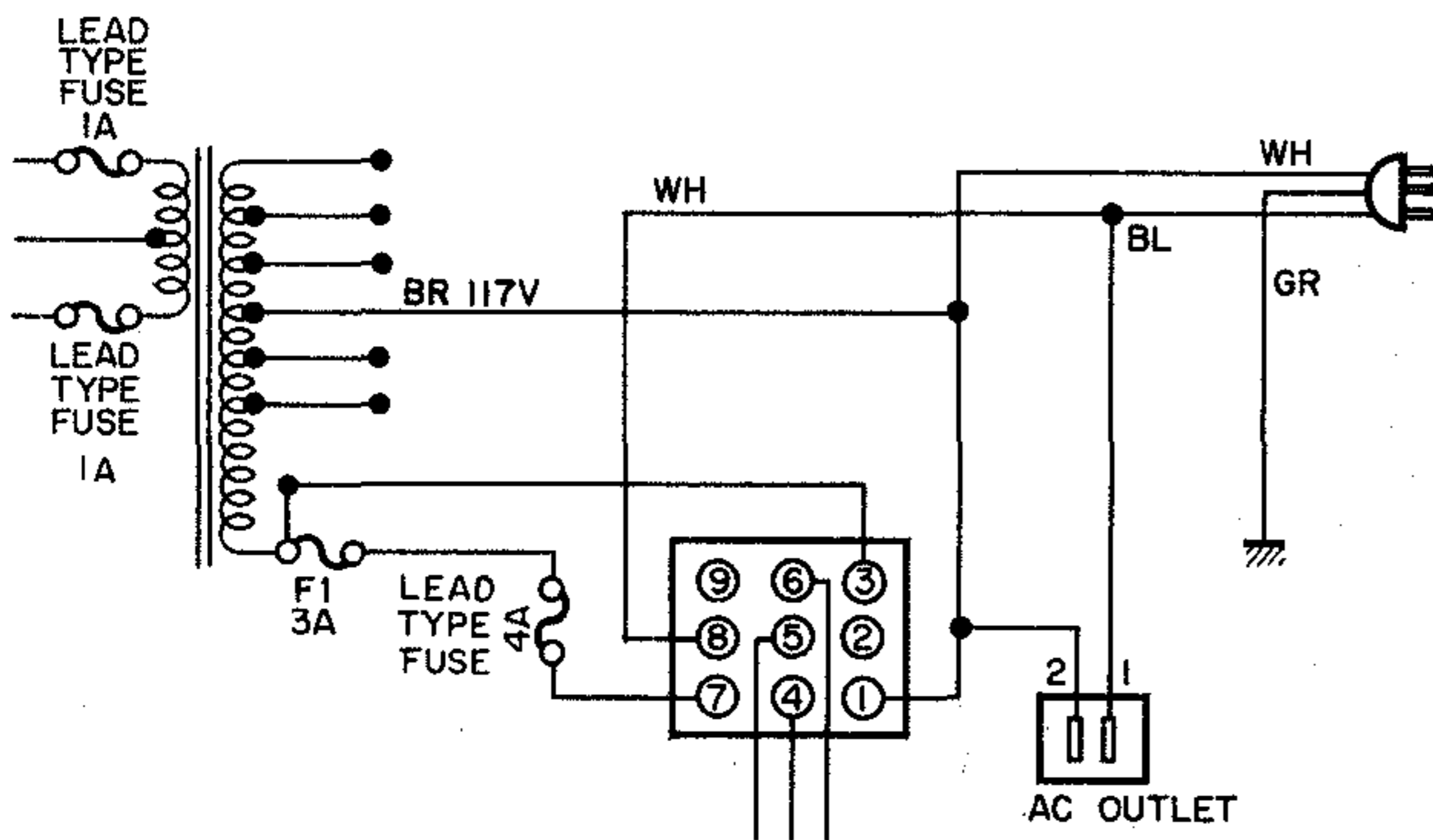

TREMOLO UNIT SCHEMATIC

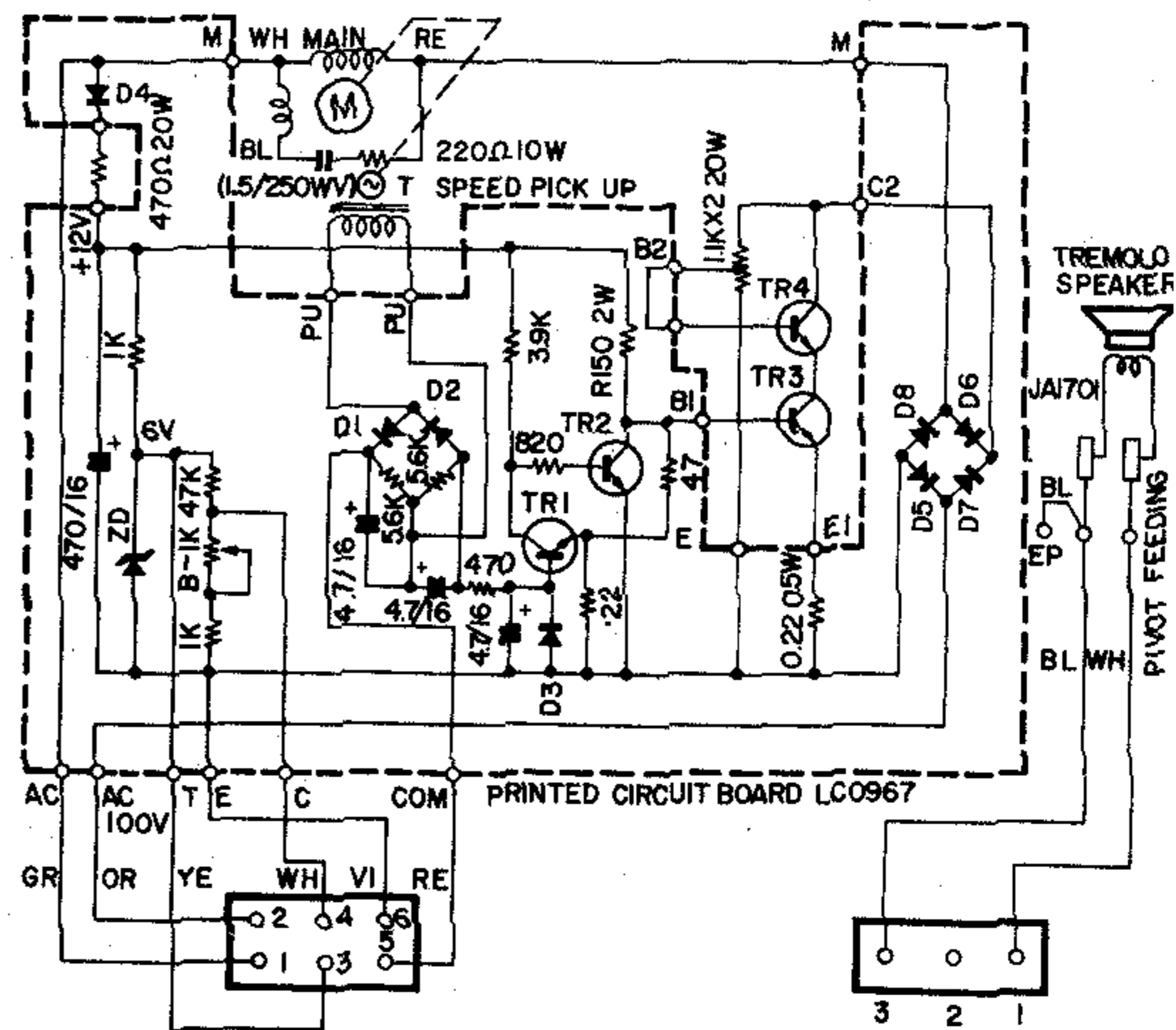

- NOTES:
- Motor : YAMAHA JC 00008 (4P)
 - D1 ~ D3 : Germanium Diode 1N34
 - ZD : Zener Diode 1S1715 6V
 - D4 ~ D8 : Silicon Diode 10D-4
 - Tr1 : 2SC458(A)
 - Tr2 : 2SC753(Y)
 - Tr3 : 2SD259
 - Tr4 : 2SD259 } hFE 75~160
 - R : Metal Oxide Resistor

▼ EUROPEAN MODEL

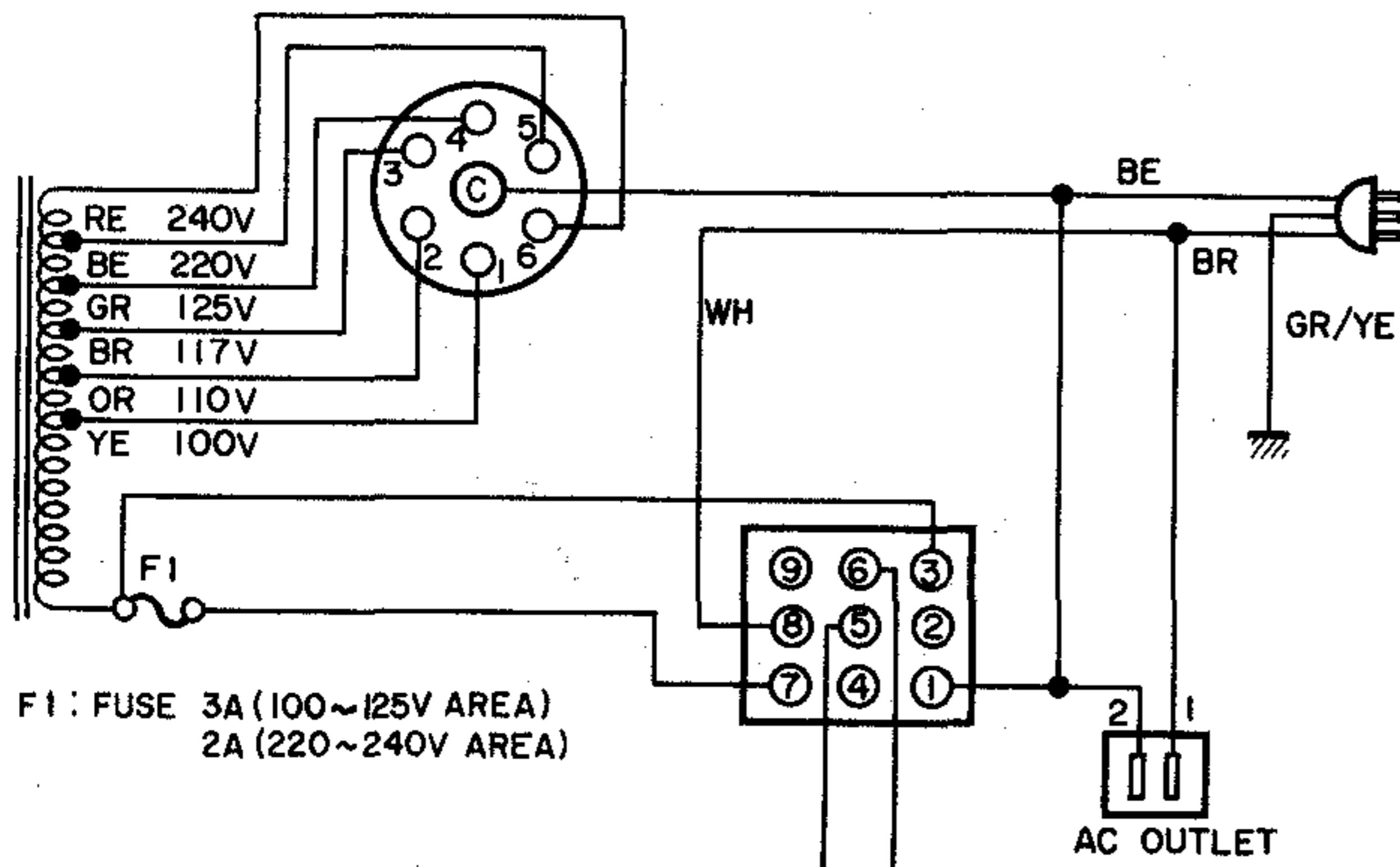

F1 : FUSE 3A (100~125V AREA)
2A (220~240V AREA)

Yamaha Combo Amplifier
Model RA - 100
Yamaha Europa G.m.b.H.
GSB-019 10.12.75

ELECTRICAL CHECKS AND ADJUSTMENTS

EQUIPMENT REQUIREMENTS

- Use a signal generator with an output impedance of under $1k\Omega$.
- The oscilloscope, level meter and other equipment should each have more than $100k\Omega$ input impedance.

OUTPUT POWER

- Set the Volume, Bass, Treble and Reverb controls to maximum.
- Connect a 4Ω load to the output terminal.
- Feed a $-22dBm/450Hz$ signal in through the High Input jack.
- Output signal level should be $+27.8dBm$ (90W).
- In this condition the distortion factor should be under 3%.

FREQUENCY RESPONSE

- Set the Volume, Bass and Treble controls to maximum, Reverb to minimum.
- Feed a $-46dBm$ signal in through the High Input jack.
- At this time check that the output level variation falls within $\pm 3dB$ of the standard characteristics.
- Leave the unit in this condition and connect the foot switch to the Tremolo Remote Control jack. When the Voice switch is set on and off check the frequency response characteristics; no major deviation should occur.

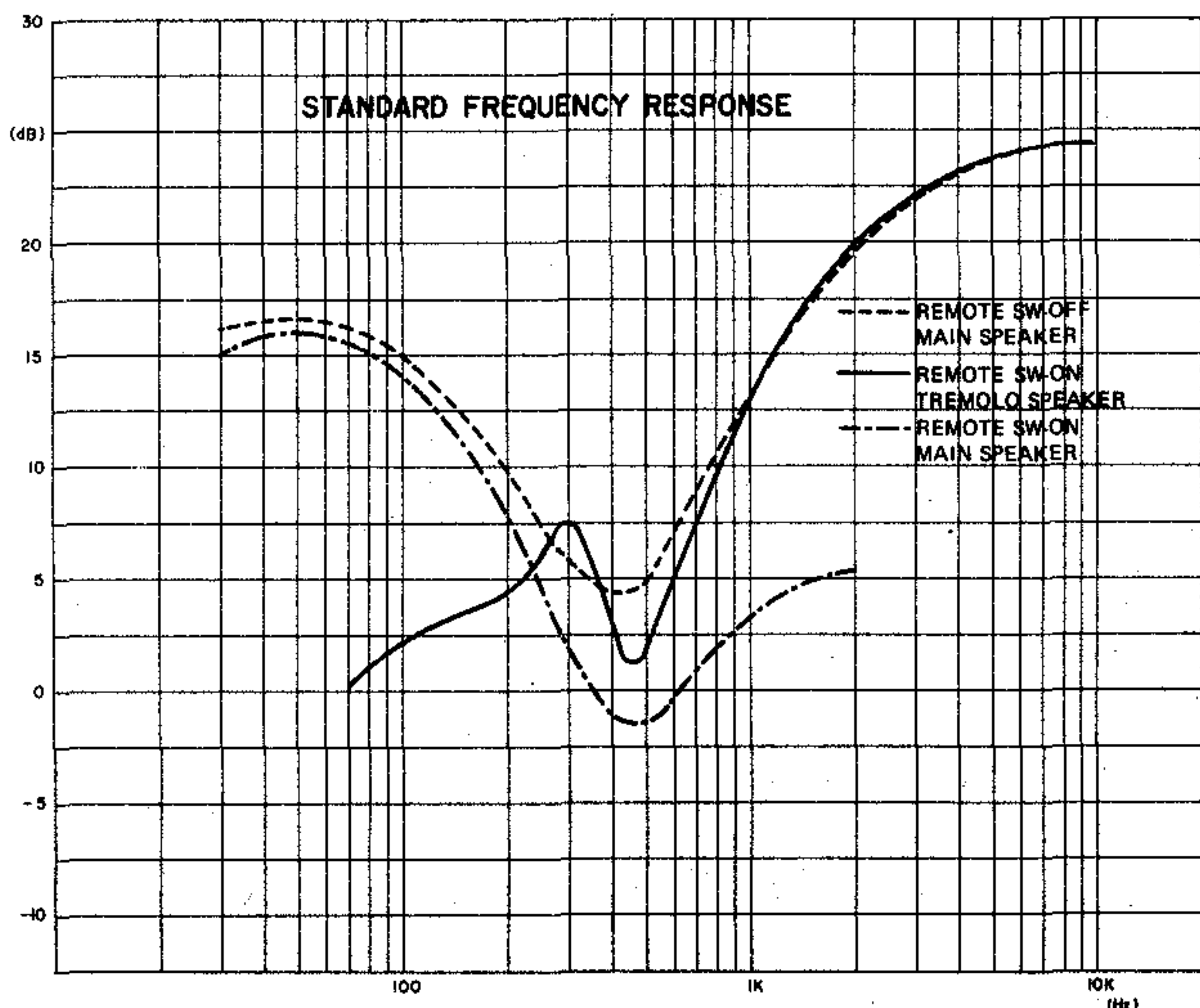

TREBLE CONTROL CHARACTERISTICS

- Set the Volume, Bass and Treble controls to maximum, the Reverb to minimum.
- Feed a 7kHz signal in through the High Input jack. The input level must be set so that the output signal is not distorted.

- When the Treble control is turned from maximum to minimum, variation must be $20dB\pm 3dB$.

BASS CONTROL CHARACTERISTICS

- Set the Volume, Bass and Treble controls to maximum, the Reverb to minimum.
- Feed a 80Hz signal in through the High Input jack. The input level must be set so that the output signal is not distorted.
- When the Bass control is turned from maximum to minimum, variation must be $16dB\pm 3dB$.

REVERB SENSITIVITY ADJUSTMENT

- Set the Bass, Treble and Reverb controls to maximum, the Volume to minimum.
- Feed Electone Flute 8' C3~B3 (all seven notes at the same time) in through the High Input jack at $-26dBm$.
- Adjust reverb sensitivity with the preamp circuit board variable resistor ($B47k\Omega$), so that the output terminal signal is $+6dBm\pm 4dB$.

REVERB DRIVE IC IDLING CURRENT ADJUSTMENT

- Within ten seconds after switching on the power the voltage between +12 and TP terminals on the preamp circuit board must be adjusted to $365\pm 10mV$ ($8\pm 0.2mA$) with the variable resistor ($B4.7k\Omega$) for idling current adjustment. Ten minutes after switching on the power this value should be $329\sim 611mV$ ($7\sim 13mA$).

TREMOLO SPEED

- Connect the foot switch to the Tremolo Remote Control jack and set the Tremolo/Chorus selector to Tremolo.
- Turn the Tremolo Speed control all the way to the left; at this time tremolo speed should be $1\sim 2.5r.p.s.$
- Turn the control all the way to the right; the speed should be $6.5\sim 7.3r.p.s.$

NOISE LEVEL

- Set the Volume, Bass and Treble controls to maximum, the Reverb to minimum.
- With no plug inserted into the Input jack the noise level should be under $-30dBm$. During this check, make sure the power switch is set to the On position which provides the lowest hum level.