

Circuit Board (Input, Output, FTSW Board)

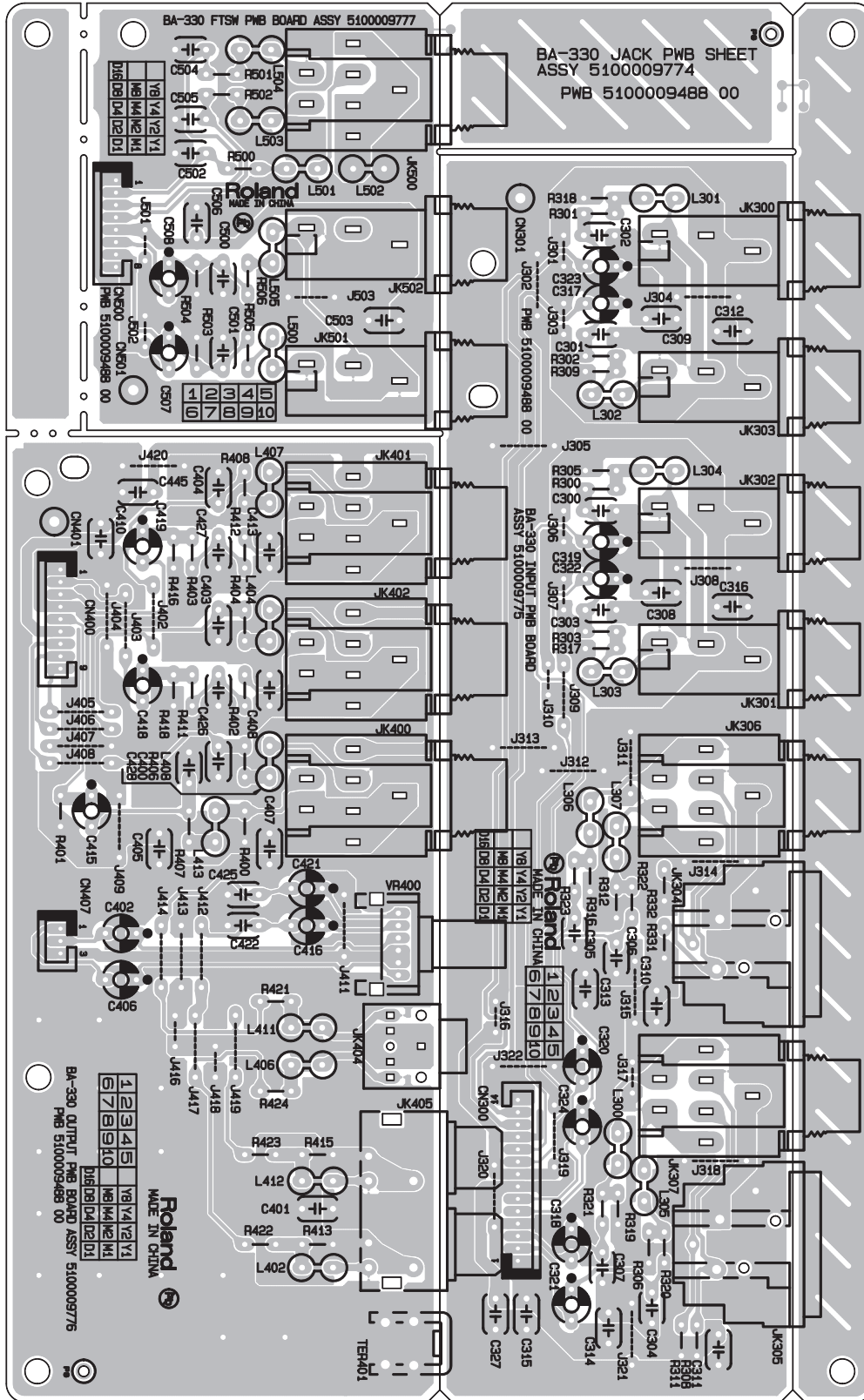

Circuit Diagram (Input Board)

INPUT BOARD

* Under the following settings
 Vol :MAX
 EQ :center
 Tone:center
 EFX :OFF
 ANTI:OFF
 Eco :MAX

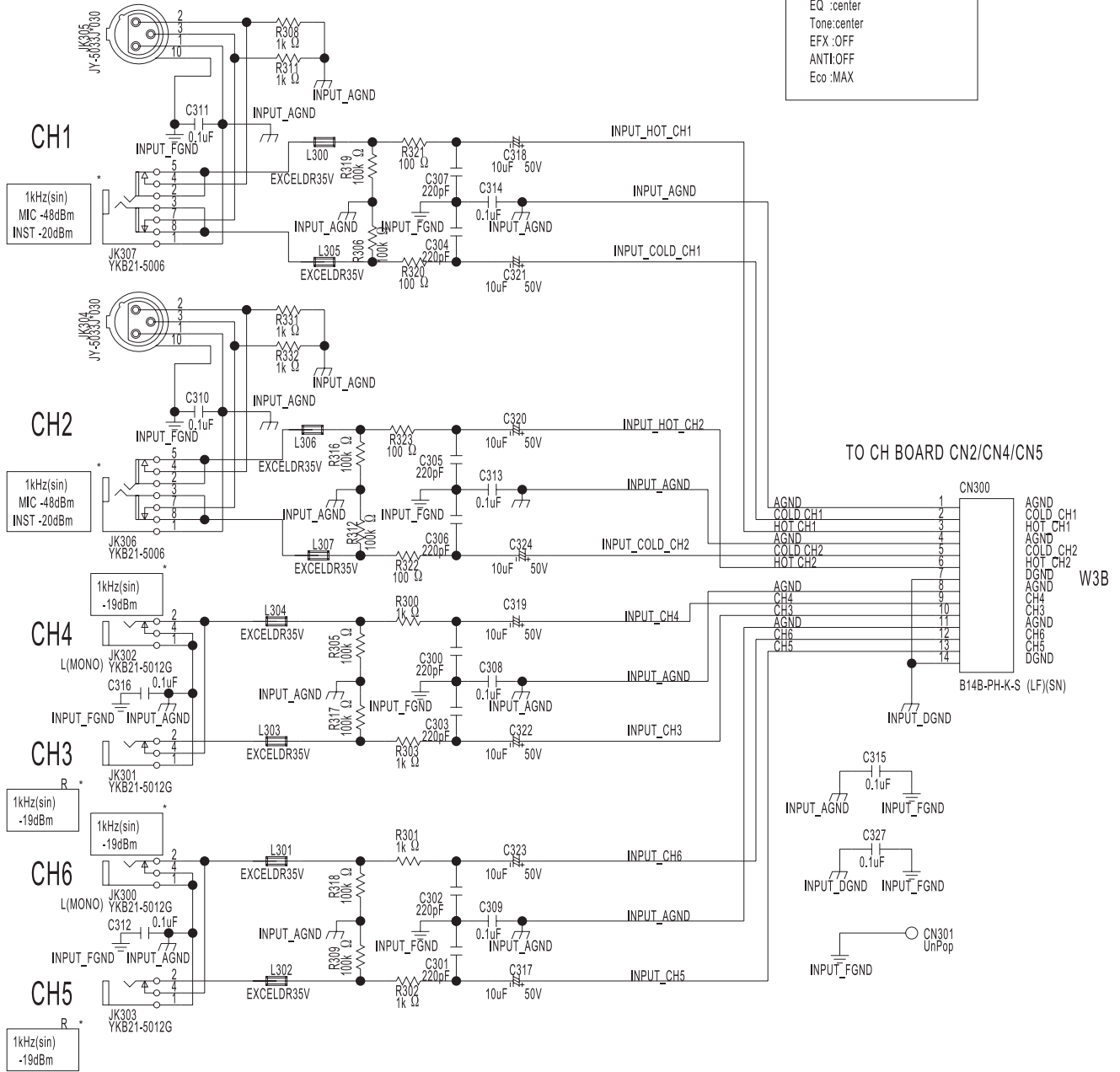

Circuit Diagram (Output Board)

OUTPUT BOARD

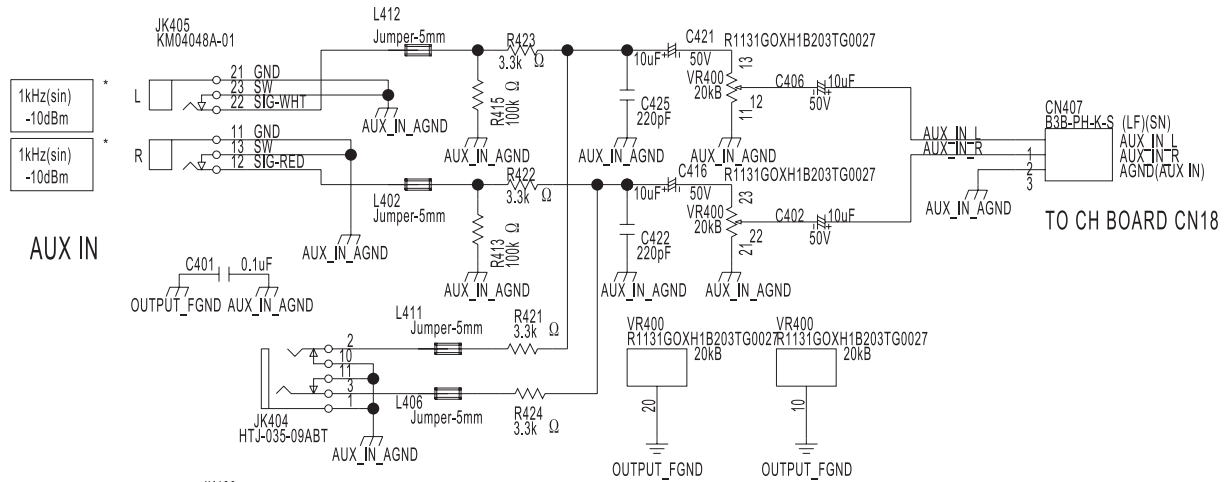

STEREO LINK IN

1kHz(sin)
-12dBm

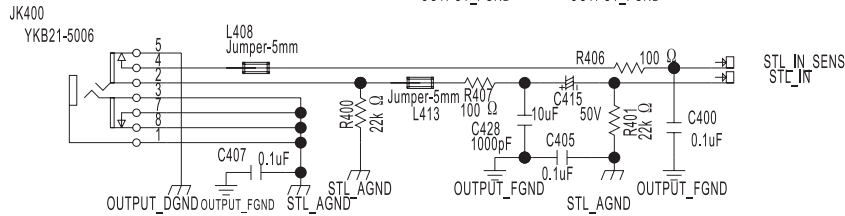

STEREO LINK OUT L

1kHz(sin)
-12dBm

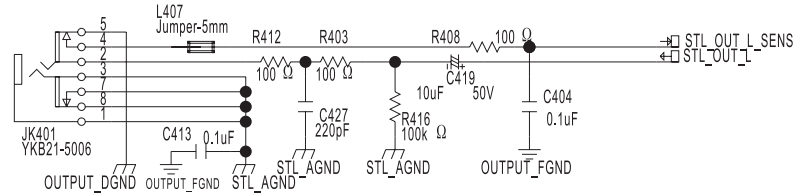

STEREO LINK OUT R

1kHz(sin)
-12dBm

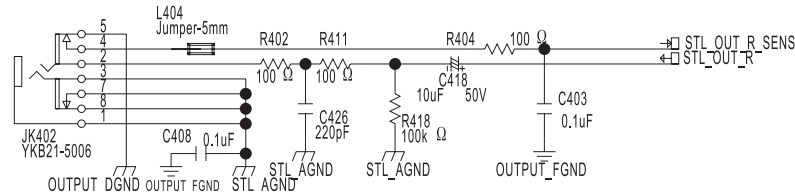

Under the following settings
 Vol :MAX
 EQ :center
 Tone:center
 EFX :OFF
 ANTI:OFF
 Eco :MAX

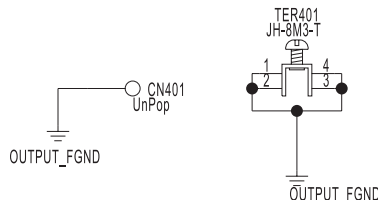
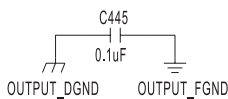
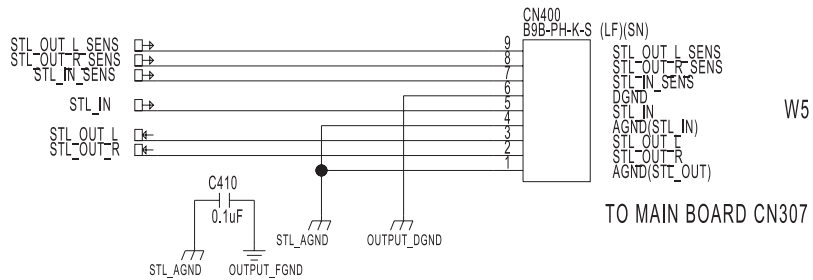

Circuit Diagram (FTSW Board)

FTSW BOARD

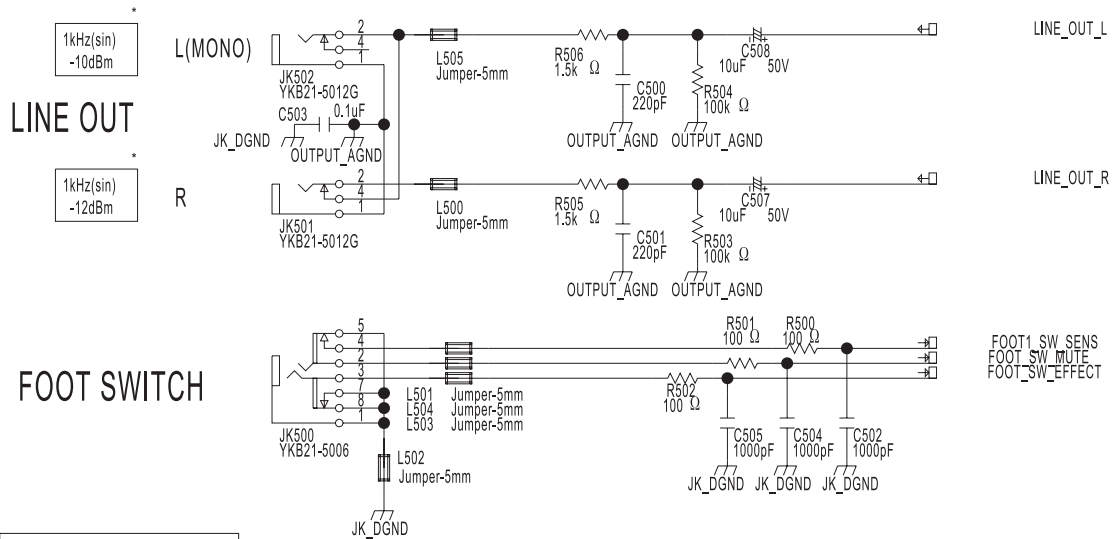

* Under the following settings
 Vol :MAX
 EQ :center
 Tone:center
 EFX :OFF
 ANTI:OFF
 Eco :MAX

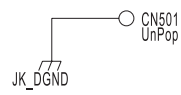
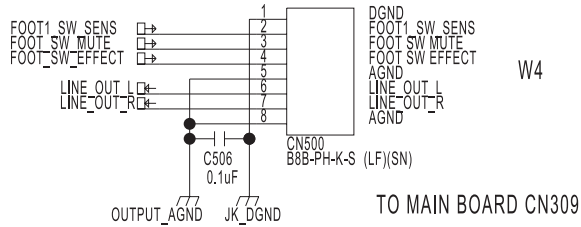

MEMO