

# Piezo Tweeter Application Note

## Piezo Tweeter Construction

Let's consider, in detail, the construction of the CTS Super Horn piezo tweeter. Although developed and patented in the early 1970s, it is still a workhorse in commercial sound installations. The circular PZT bimorph in this case consists of two wafers, 0.89" in diameter and 0.0055" thick. The ultra-thin wafer is required to achieve the desired acoustical performance. The bimorph is coupled at it's center to the apex of a specially impregnated diaphragm which then works into a compression volume. Slots in the compression the compression space direct the sound into the throat of the horn. The radial slots are transformed into a 3" circular mouth through the unique shape in the throat of the horn. The actual horn contour is a hybrid design between a pure exponential contour and a hyperbolic one. Again, this computer-generated geometry is optimized for the best acoustical output.

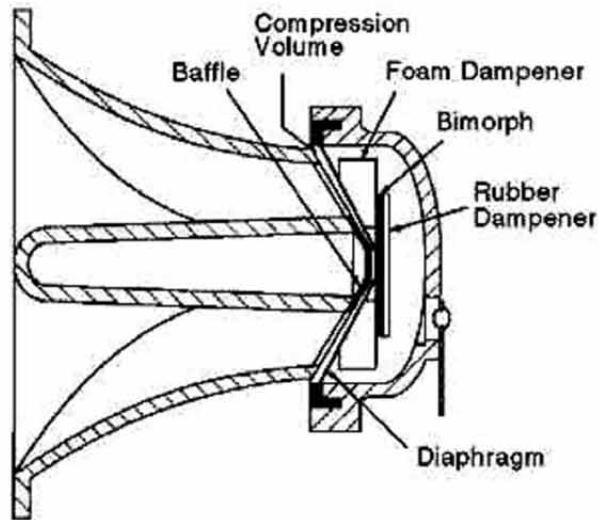

The result is a frequency response (Figure 6) showing high sensitivity and smooth characteristics. Again, it should be noted that low quality products are available on the market using poorly tooled parts and imprecise manufacturing methods. The results are inferior performance and unpredictable results. CTS is proud of its commitment to quality and the consistently high performance of the full line at CTS piezoelectric speakers.

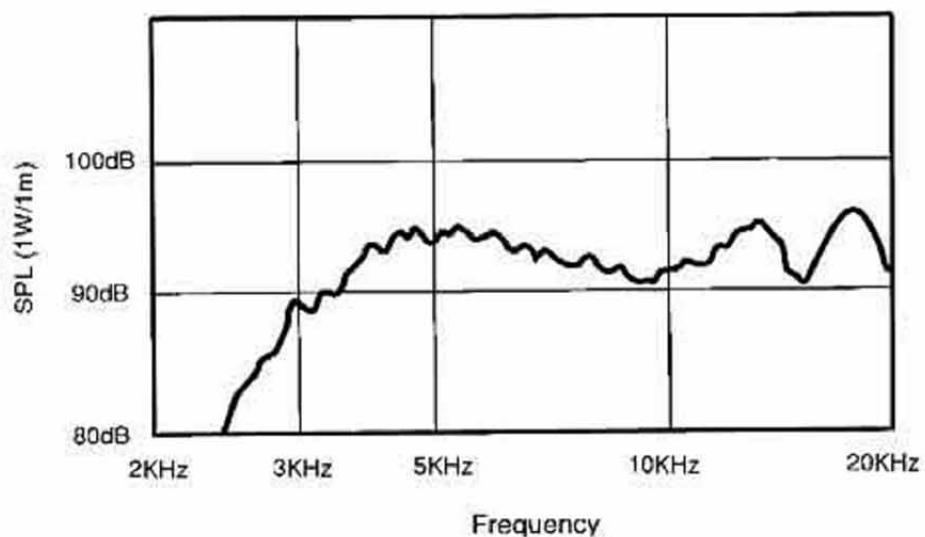

Fig. 6 Super Horn frequency response

## Piezo Tweeter Performance

Because of the light dynamic mass of the piezo tweeter (no voice coil, spider, etc.), the response is very fast. Tone burst measurements show the excellent transient response at all frequencies across the band.

A further advantage of the piezo tweeter is its high-power efficiency. With no voice coil, there is no resistive heating and little lost acoustical power. In fact, the actual impedance of the tweeter (Figure 7) is very high, from about 50 ohms to 250 ohms for the Super Horn in its operating range. At these values, the amplifier sees the little additional load from the tweeter, allowing use of arrays with little additional power load. Because it generates little waste energy it is capable of being driven harder than the dynamic tweeter.

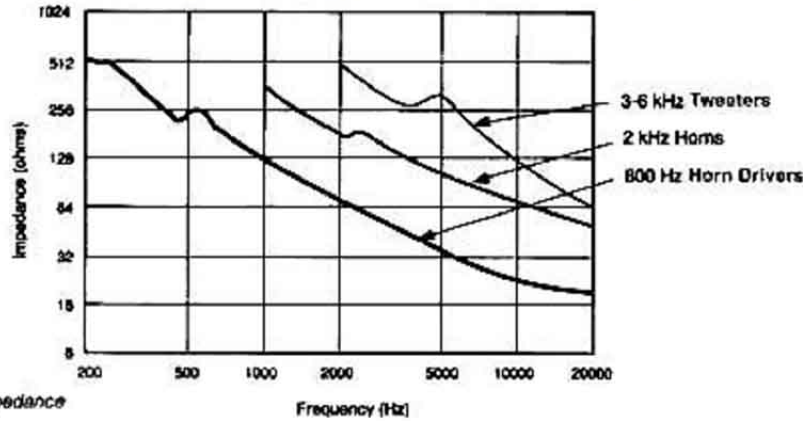

Fig. 7 Piezo speaker impedance

## Application Hints

With all the aforementioned virtues of piezo tweeters, there are still some issues in their use with which the design engineer should be familiar.

The piezo tweeter appears like a lossy capacitor to the amplifier (Figure 8). As shown in the impedance plot (Figure 7) the impedance decreases with frequency. Many amplifiers today boast outputs that extend to 100 kHz. At those frequencies, ultrasonic resonances may occur between the amplifier and the tweeter, causing damage to one or the other or both.

If such an amplifier is used, particularly with an array of tweeters, a small series resistor is suggested (Figure 9). For CTS tweeters with a low-end cutoff of 3 kHz to 6 kHz, a 50 ohm, 2 watt resistor wired in series with each tweeter will prevent this resonance problem without noticeably affecting the response. It should be noted that this problem is uncommon in automotive applications since these amplifiers usually roll off at 20 kHz. The 2 kHz horn products do not require an external series resistor since one is built into each unit. The KSN1086 mid-range driver and KSN1090 and 1103 voice range products should be protected with a 20 ohm, 10 watt series resistor.

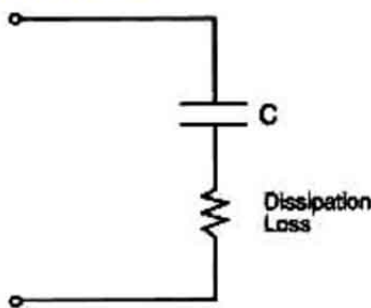

C	= .12 $\mu$ F for 4 kHz Tweeters
	= .30 $\mu$ F for 2 kHz Horns
	= 1.2 $\mu$ F for 800 Hz Horn Driver

Fig. 8 Piezo tweeter equivalent circuit

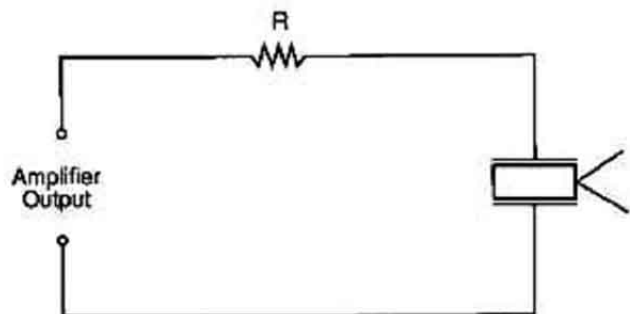

Speaker Family	R
3-6 kHz Tweeters	50 $\Omega$ 2W
2 kHz Horn	Not Required
800 Hz Horn Driver	20 $\Omega$ 10W

Fig.9 Protective series resistor

## Crossover Networks

The piezo tweeter does not require a crossover network. Since the tweeter is capacitive in nature, it rejects low-frequency power. However, if the mid-range is still operating at the turn-on of the tweeter (4 kHz in the case of the Super Horn), a harshness may be heard in the total system. This disturbance in the crossover region can be minimized by the addition of an R-C filter (Figure 10) tuned to attenuate the turn-on peak, rolling off the mid-range a little earlier.

If a conventional crossover network is to be used, the tweeter must be made to look "resistive" in order to work with the crossover. This can be done by wiring an 8 ohm resistor /across/ the piezo tweeter. It should be noted, however, that the power efficiency benefits are now lost since the piezo tweeter will look more like an 8 ohm dynamic unit electrically. It will, however, allow the use of conventional crossover technology. If a variable level attenuation is desired, an L-Pad can be used.

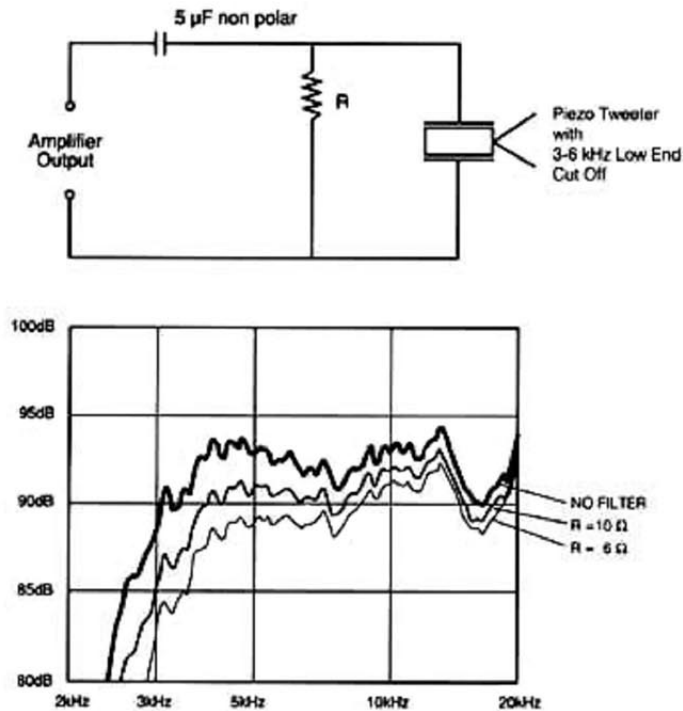

Fig 10 Single stage R-C filter for attenuating turn on response

If a straight level attenuation is desired, a simple (non-polar) capacitor (Figure 11) can be series wired.

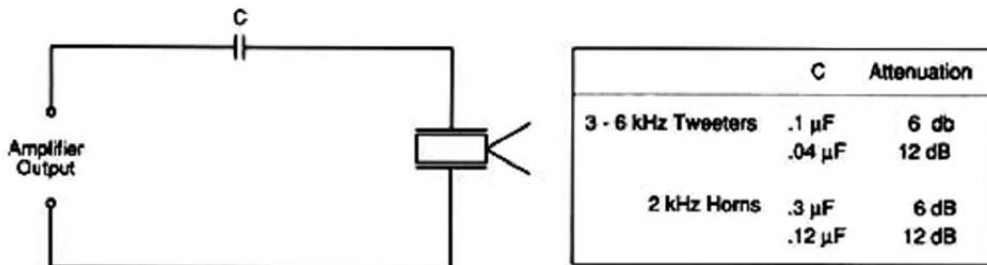

Fig. 11 Series attenuating capacitor

## Multiple Tweeters

System sensitivity can be increased by adding piezo tweeters in parallel (Figure 12). The high electrical impedance of CTS' piezo tweeters allows several units to be connected in parallel without overloading the amplifier.

Each time the number of tweeters connected in parallel is doubled, the average sensitivity for the array increases by 3 to 6 dB. The actual increase depends on factors such as off-axis angle, frequency, tweeter model and the configuration of the array. For CTS Super Horns, the on-axis response increases 6 dB for each doubling. Part of this increase occurs because of the narrower beam produced by multiple horns. As the beam becomes narrower, the off-axis response degrades as a result of destructive interference between tweeters. The angle at which the destructive interference is the greatest depends on the frequency and on the spacing between the tweeters.

The destructive interference can be minimized in one plane by orienting a single row or column perpendicular to that plane. For example, if horizontal dispersion is more important than vertical, the tweeters should be mounted in a single vertical column. This assures that the horizontal dispersion of the array is identical to that of a single tweeter. The vertical dispersion, however, can begin to degrade significantly beyond 5 degrees. Mounting the tweeters at an angle (off-axis) with respect to one another can also improve the off-axis response.

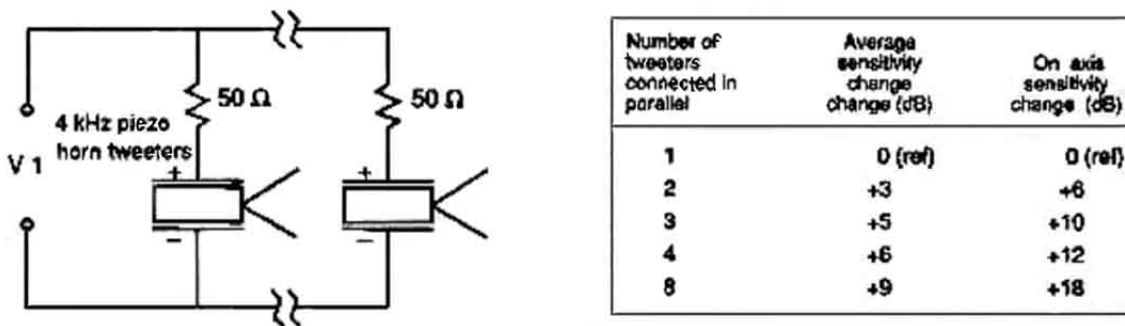
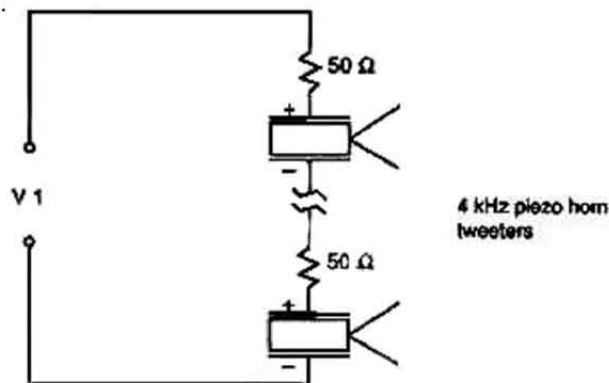

Fig. 12 Output level increase for parallel connected piezo tweeters

Connecting piezoelectric tweeters in series doesn't increase system sensitivity, but it does higher sound pressure levels at maximum rated power (Figure 13). maximum power handling capability of the array increases as tweeters are added in series. At maximum rated drive level, doubling the number of tweeters in series reduces the voltage across each tweeter by half with the resulting SPL decrease of 6 dB for each tweeter. The additional tweeters, however, create a 6 dB increase for a net on-axis sensitivity change of 0 dB. If the voltage applied to the array is now doubled, so that each tweeter sees it's maximum rated voltage, the array's on-axis SPL increases 6 dB.



Number of tweeters connected in series	Average sensitivity change (dB)	On axis sensitivity change (dB)	On axis SPL at max. power rating (dB)	Max. array EIA voltage (V1 rms volts)	Max. array EIA power (watts rel. to 8 ohms)
1	0 (ref)	0 (ref)	0 (ref)	25	75
2	-3	0	+6	50	300
3	-5	0	+10	75	700
4	-6	0	+12	100	1250

Fig. 13 Output level for series connected piezo tweeters

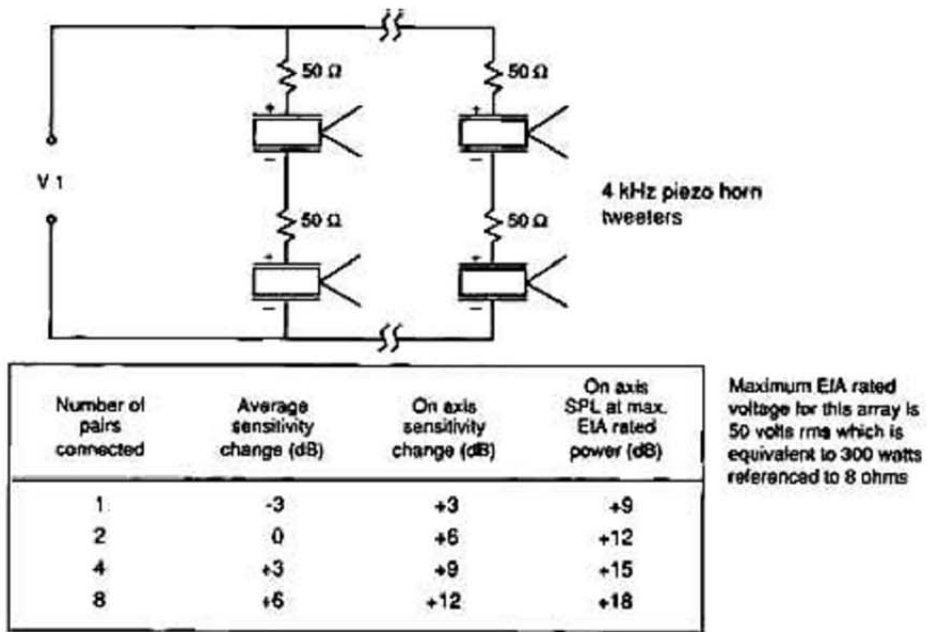

Fig. 14 Output level for parallel connected, series pairs of piezo tweeters

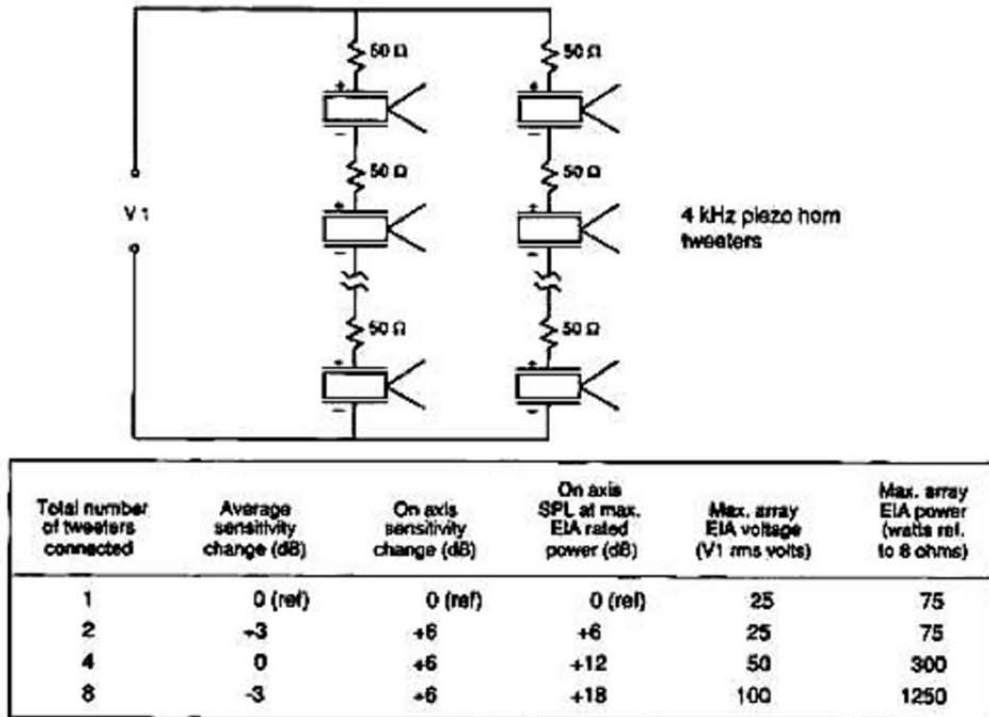

Fig. 15 Output level for two strings of series connected Piezo Tweeters

## Power Handling

The power rating of CTS piezoelectric speakers is determined using the EIA RS426 test method. This is a continuous 8 hour noise test with peak voltage spikes twice (4 times higher in terms of power) the average applied signal. Thus, for a speaker to be rated at 75 watts (25 volts), it must not degrade after 8 hours of continuous operation at 75 watts with 300 watt spikes. As a result of using the EIA test method, CTS power ratings for its piezoelectric speakers tend to be conservative compared to conventional industry claims for speaker systems. In addition, the extremely dense, high-quality ceramic manufactured by CTS withstands cracking and other high power failure mechanisms much better than the piezoelectric ceramic used by many other manufacturers.

## Powerline Series

The Powerline series of 2 kHz horns use an internal protection circuit which allows the horn to continuously handle the full output of a 400 watt (8 ohm reference) amplifier.

The protector is a parallel combination of a miniature light bulb and a positive temperature coefficient resistor (PTC)(Figure 16).

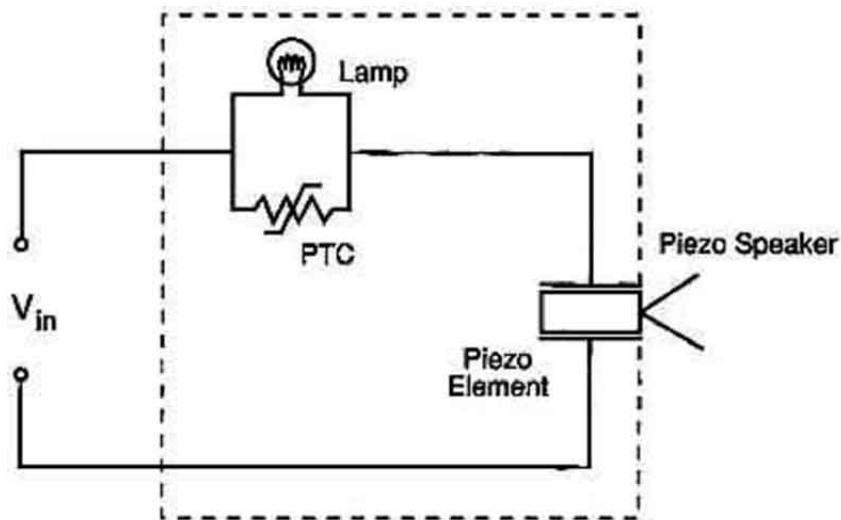

*Fig. 16 Powerline internal protection circuit*

In a music system in which there is excessive clipping at high power, or high-amplitude high-frequency signal content, the piezo drive element sees very large currents and will heat up due to dissipation losses. When the PTC senses the high temperature it increases its resistance dramatically. This has the immediate effect of significantly lowering the power into the driver, and the SPL produced. To avoid this sudden shift, and make the power control practically imperceptible, the miniature lamp is wired in parallel with the PTC. The lamp is essentially a very fast-acting PTC and responds to music peaks rather than RMS heating as does the PTC. The audible effect is similar to that produced by a level compressor. In this way, the driver is held below damaging levels.

The resulting speaker performance then is as follows: under normal operating conditions, the powerline speaker performs in its normal mode, faithfully reproducing the signal applied in proportion to its volume. Under temporary, extremely high power surges (even in excess of 400 watts), the speaker will still perform in its normal expected mode. But now, if subjected to continuous high-frequency power, above 100 watts or so, the PTC temporarily opens up, allowing the speaker to continue to play, drawing its power through the light bulb, at a somewhat compressed power level. The transition is smooth, and at the power levels being played at the time, barely perceptible to the human ear. When the speaker cools off, the PTC automatically resets, and conditions return to normal.

## Conclusion

The CTS product line of piezo tweeters has grown dramatically since the Super Horn made its debut 18 years ago. CTS' speaker portfolio now includes mid-range drivers, voice range products, 2 kHz horns, and the Power Line family. CTS is committed to total customer satisfaction. With the wide variety of models available, and the technical tips provided herein, we are confident we can satisfy your audio design needs.