

GUITAR AMPLIFIERS
T-Series Vacuum Tube Amplifiers

SERVICE MANUAL

MODELS

T100C and T100
T50C and T50

CONTENTS

Important Notice.....	1
Specifications.....	2
Front Panel Layout and Features.....	3
Functions of Controls.....	4
Rear Panel Layout and Features.....	5
Troubleshooting.....	6 - 10
Tube Functions.....	11 - 12
Bias Adjustment.....	13
Production Up-dates.....	14
Circuit Board Layout T100/T50C.....	15
Circuit Board Layout T100/T50.....	16
MB Circuit Board.....	17
PB and Tone Circuit Board.....	18
Block Diagram.....	19
Schematics.....	20 - 22
Parts List.....	24 - 29

IMPORTANT NOTICE

This manual has been provided for the use of authorized Yamaha Retailers and their service personnel. It has been assumed that basic service procedures inherent to the industry, and more specifically Yamaha Products, are already known and understood by the users, and have therefore not been restated.

WARNING: Failure to follow appropriate service and safety procedures when servicing this product may result in personal injury, destruction of expensive components and failure of the product to perform as specified. For these reasons, we advise all Yamaha product owners that all service required should be performed by an authorized Yamaha Retailer or the appointed service representative.

IMPORTANT: The presentation or sale of this manual to any individual or firm does not constitute authorization, certification, recognition of any applicable technical capabilities, or establish a principle-agent relationship of any form.

The data provided is believed to be accurate and applicable to the unit(s) indicated on the cover. The research, engineering, and service departments of Yamaha are continually striving to improve Yamaha products. Modifications are, therefore, inevitable and changes in specification are subject to change without notice or obligation to retrofit. Should any discrepancy appear to exist, please contact the distributor's Service Division.

WARNING: Static discharges can destroy expensive components. Discharge any static electricity your body may have accumulated by grounding yourself to the ground buss in the unit (heavy gauge black wires connect to this buss).

IMPORTANT: Turn the unit OFF during disassembly and parts replacement. Recheck all work before you apply power to the unit.

WARNING: CHEMICAL CONTENT NOTICE!

The solder used in the production of this product contains LEAD. In addition, other electrical/electronic and/or plastic (where applicable) components may also contain traces of chemicals found by the California Health and Welfare Agency (and possibly other entities) to cause cancer and/or birth defects or other reproductive harm.

DO NOT PLACE SOLDER, ELECTRICAL/ELECTRONIC OR PLASTIC COMPONENTS IN YOUR MOUTH FOR ANY REASON WHAT SO EVER!

Avoid prolonged, unprotected contact between solder and your skin! When soldering, do not inhale solder fumes or expose eyes to solder/flux vapor!

If you come in contact with solder or components located inside the enclosure of this product, wash your hands before handling food.

SPECIFICATIONS

	T-50	T-50C	T-100	T-100C
OUTPUT POWER	50 WATTS	50 WATTS	100 WATTS	100 WATTS
TUBES	2-6L6GC OUTPUT 7-12AX7 PREAMP	2-6L6GC OUTPUT 7-12AX7 PREAMP	4-6L6GC OUTPUT 7-12AX7 PREAMP	4-6L6GC OUTPUT 7-12AX7 PREAMP
SPEAKER		1-12" CELESTION G12M-70		1-12" CELESTION G12H-100
INPUTS	INSTRUMENT, EFFECTS RETURN			
OUTPUTS	SPEAKER X 2, EFFECTS SEND, SLAVE OUT, FOOTSWITCH, AC OUT			
ACCESSORIES	FOOT SWITCH, CORD			
FRONT PANEL CONTROLS	PREAMP X 2, BASS X 2, MIDDLE X 2, TREBLE X 2, MASTER X 2, REVERB X 2, PRESENCE, POWER, STANDBY			
REAR PANEL CONTROLS	SLAVE OUT LEVEL, IMPEDANCE SELECTOR			
POWER REQUIREMENTS	120V AC, 60Hz			
DIMENSIONS (H x W x D)	8½" x 20½" x 11" 216mm x 521mm x 279mm	18" x 18⅞" x 10½" 457mm x 473mm x 267mm	8½" x 20½" x 11" 216mm x 521mm x 279mm	18" x 18⅞" x 10½" 457mm x 473mm x 267mm
WEIGHT	35 LBS. (77 kg)	45 LBS. (99 kg)	40 LBS. (86 kg)	57 LBS. (125 kg)
OPTIONAL ACCESSORIES	COVER			

On-going improvements to the Yamaha T series line may occur, therefore specifications are subject to change

Celestion is a registered trademark of Celestion Industries, Inc.

FRONT PANEL LAYOUT AND FEATURES

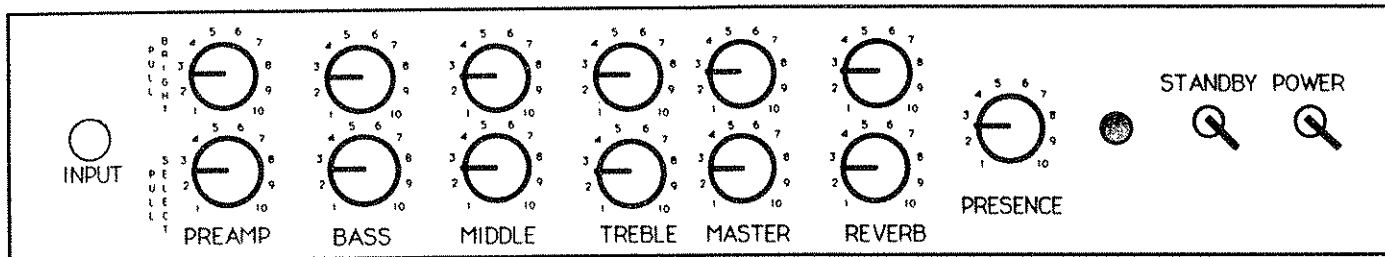

Note: Top row of controls is for the Clean Channel. Bottom row of controls is for the Overdrive Channel. (This is the same for both combo and head chassis).

Input: Plug your guitar in here for input to both footswitchable channels.

Clean Channel Preamp: A most powerful control! This knob will determine the Clean voice of your amp. Lower settings (2 - 5) will yield "jazzy to funky" very clean tones. (For the most efficient clean sound, set this as high as possible before clipping /distorting.) For those that like some teeth to their rhythm, higher settings will provide some pleasant surprises. As the control goes from 5 to 10 you'll notice several unique voices appear. From grimey "broken rhythm" to stinging blues, you'll find a wider variety of tones than any other two channel amp!

Recommended starting point: 4 - 6.

Pull Bright: This switch adds sparkle and bite to the Clean Channel only. With this pulled out, you might use a lower treble/presence combination.

Overdrive Channel Preamp: A monster in disguise! In this control you'll find gain, gain, and more gain. Low settings (2 - 4) will knock your socks off, tones here are powerful, punchy, and potent! As you turn it higher, you'll find singing sustain, buzz saw overdrive and finally endless harmonics. As with any high-gain preamp, the higher you set this control, the softer and mushier the tones. When playing louder - use less of this control.

Recommended starting point: 4

Pull Select: By pulling this control you will manually select the Overdrive Channel. When using an external footswitch the front panel switch will be disabled.

FUNCTION OF CONTROLS

Bass: Truly a Soldano signature feature, this control on the Clean channel adds body and depth. On the Overdrive channel it's the famous "chunk, chunk, chunk" that many have paid dearly for. (no mods needed here)

Recommended starting points: Clean 6 / Overdrive 4

• Note: With higher Lead Preamp settings use a lower Bass setting.

Middle: The most "active" control! Ranges from "no middle" hollowness to the fattest, beefy mids heard. This control may be "the key" to your tone.

Recommended starting points: Clean 7 / Overdrive 4

Treble: This is Mr. Personality. Use this control to add top end sizzle and bite. Experiment with different combinations of treble and "Pull Bright" in the Clean Channel, and remember if it's set too high on the Overdrive Channel with too much "Preamp", the amp may squeal. (simply turn down the treble or preamp to remedy)

Recommended starting points: Clean 7 / Overdrive 5

Master: Unlike other two channel amps, your new Yamaha amp features completely independent master volume controls. This control determines the overall loudness of the amp.

Remember to use these for "tone" also. Try a higher setting on the Clean Master for an amazing blues tone. But be careful, this amp gets LOUD! Any volume level may be obtained from bedroom metal to concert volume. In regular use try to keep these controls close in value.

Note: In extreme settings like high Overdrive levels with very low Clean levels some channel bleed will be heard.

Recommended starting points: Clean 2 / Overdrive 2

Reverb: A classic amp feature! We've included the finest Accutronics 3 spring reverb with separate level controls for each channel. Higher settings deserve "surf licks" !

Recommended setting: Both channels 2 - 3

Presence: As this control works on the power amp sections, it affects both channels at the same time. You'll notice it adds overall brightness and clarity most apparent in the upper ranges of the control from 6 to 10.

Standby: An important power tube saver! This switch controls the high voltage going to the output tubes. Use it when warming up, between sets and before powering down and you'll prolong the life of your tubes. Flip the switch up to operate, down for Standby.

Power: Up is on, down is off.

REAR PANEL LAYOUT AND FEATURES

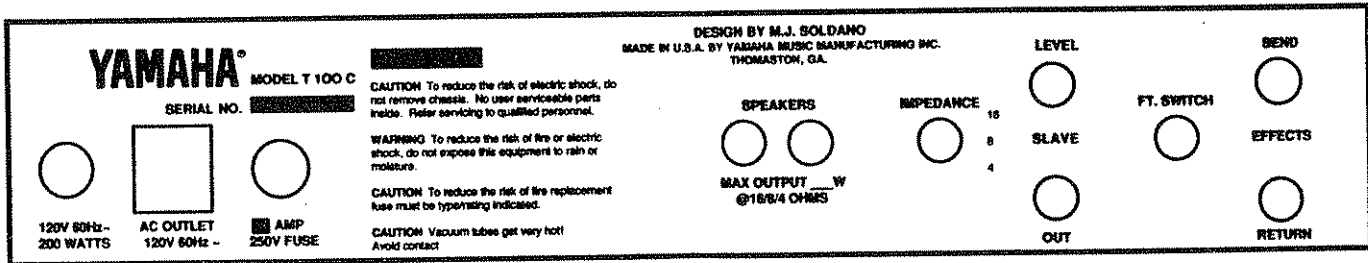

Effects Loop

Send Jack: Use a shielded "guitar type" cable to connect this "output" to the input of your external effects.

Return Jack: Use a shielded cable to "return" the output of your external effects to this effects return "input" of your amp.

Footswitch Jack: This is where you will connect the cable going to your footswitch. You may use either a shielded (guitar) cable or an unshielded (speaker) cable. Also note; should you ever lose/misplace or forget your YAMAHA footswitch, any "latching" (switch to ground) type of footswitch will work.

Slave Out Jack: For those that choose to "Slave" their amp into a component style rack system, take output signal from here. *Note:* While slaving you still **must have** a speaker or resistive load connected to this amp or damage will occur.

Slave Out Level Control: This controls the amount of signal sent from the "slave out jack".

Speaker Impedance Selector Switch: Use this switch to properly match your amp to speaker or speaker cabinet(s) impedance. Please read the page on "Speaker Output" for detailed information.

Speaker Output Jacks: These jacks connect the output from your amp to the input of your speaker(s). Use a high quality UNSHIELDED speaker cable(s) ONLY.

Fuse: Replace only with the type and rating indicated on the chassis. It's a good idea to always carry some spares because of the effect of bad power tubes. If this fuse "blows", please review the Power/Output Tube page and check for a bad tube.

Aux. AC Outlet: We've added this outlet for your convenience. Use it for external effects, tuners, etc. Just don't exceed the maximum rating which is 300w.

TROUBLESHOOTING

TESTING CONDITION:

Set the unit to the following conditions:

1. Ensure power cord is plugged into a known live AC outlet (Input voltage 120 VAC).
2. Set ALL EQ controls to 10 on both channels and Presence to 0.
3. Check power cord.
4. Check both external and internal fuses.
5. If the fuse is opened, replace WITH SAME TYPE.
6. Check for a defective ON/OFF switch.
7. Set PREAMP to 1 and MASTER volume to mid position (5 - 6) on both channels.
8. Confirm speaker connection.
9. Remove any additional plug/s connected to the rear panel.
10. When troubleshooting a problem, check both CLEAN and OVERDRIVE Channels.

A. GENERAL INSPECTION AT POWER-ON

1. Check for a lit pilot LED (green or red).
2. Pull out the OVERDRIVE PREAMP control, the pilot LED should change color (RED).
3. Check the filament of the 12AX7's and/or 6L6's. Should be red in color.
4. Standby Switch in the UP position, check the plate color of the 6L6's.
5. Listen for HUM (a little hum is expected) you may need to increase the preamp and master controls. Return Preamp to 1.
6. Input a signal source (1khz at -30dB, adjust Preamp and Master control for adequate listening level).
7. If the unit is NOISY, use controls to isolate the problem area.

CAUTION: The T Series uses high voltage and output tubes run very hot.

B. POWER SUPPLY TROUBLESHOOTING

1. NO PILOT LIGHTS

Check Power Transformer (has internal one-time temperature fuse) for open.
Check Diode and filter capacitor of the B+ voltage supply.
Check Diode and filter capacitor of the low voltage supply.
Check for a defective switching relay.

2. IF FUSE BLOWS IMMEDIATELY AFTER POWER-ON (STANDBY DOWN)

Perform checks in section B1.
Check Power Transformer.

3. IF FUSE BLOWS AFTER SEVERAL MINUTES OF OPERATION (STANDBY UP)

Check the plate color of the 6L6's power tube.
Check the BIAS voltage for the 6L6's power tube.
Check for a leaky coupling capacitor on the plate of V7a and V7b.
Defective 6L6 power tube.

4. VERY LOUD HUM

Check input cable.
Check AC power cord (3 connector type).
Defective 6L6.

NOTE: If HUM goes away after the amplifier warms-up, look for defective 12AX7 tube/s (cathode to filament cold short).

C. UNIT DEAD

1. UNIT IS DEAD (no output from either channel).

NOTE 1: *With a sound source at the input, adjust the Preamp, Master and Reverb controls. Listen for sound. Check both channels. If sound is heard only after the REVERB control is increased, the problem is the Effects jack, V4a and/or it's associated circuitry. (see Block or Schematic Diagram)*

NOTE 2: *With the Master and Reverb control set to maximum, rock the unit or tap the reverb spring unit. Listen for Reverb noise. Check both channels. This procedure will divide the unit in half. If sound is heard the problem is before V4b. If NO sound is present at the output your problem is after V4b.*

NOTE 3: *Set the CLEAN PREAMP and MASTER CONTROLS for adequate listening level.*

Perform checks in section B1.

Defective V1a or associated circuitry.

Defective V3a/b or associated circuitry.

Defective V4a/b or associated circuitry.

Defective V7 or associated circuitry.

Defective Output Transformer or circuitry.

NOTE: *Use the following tubes for substitution: V2 and V6*

2. CLEAN CHANNEL IS DEAD

Defective V1b or associated circuitry.

Defective V5a or associated circuitry.

Defective CL35 coupler.

NOTE: *Use the following tubes for substitution: V2 and V6*

3. OVERDRIVE CHANNEL IS DEAD.

Defective V2a and V2b or associated circuitry.

Defective V5b or associated circuitry.

Defective CL51, OD52 or OD36 coupler.

NOTE: *Use the following tube for substitution: V6*

4. CHECKING ASSOCIATED CIRCUITRY WHEN SUBSTITUTION FAILS.

Check Power Supply Voltages.
Check plate voltage.
Check cathode voltage.
Check coupling capacitor.
Check grid voltage.

NOTE: Use voltage table in this section. All voltage measurements are with respect to power ground.

STEP 1. Use the PREAMP CIRCUITRY TUBE FUNCTION page to help pinpoint your problem area.

STEP 2. Check the plate voltage at pins 1 and 6. Compare your reading with the table. If your measurement differs from the table, proceed as follows.

NOTE: *10 to 15% variation in voltage reading is normal.*

Plate voltage is HIGHER: Measure both sides of the plate load resistor. If the tube is conducting, the plate load resistor will drop some voltage. When the plate voltage equals B+ and a plate load is in the circuitry, the tube is either cut-off or not conducting. Check for grid voltage, open cathode or plate resistor, and see if the filament is hot or red in color. Also check for filament voltage.

Plate voltage is LOWER: When the plate voltage is lower this indicates the tube is conducting more than it should. Check the control grid voltage. Check for leaky coupling capacitor between amplifier stages. Grid must be negative with respect to the cathode for normal operation.

Common-cathode circuitry: Check the cathode voltage on common-cathode circuitry with the voltage table.

Check the value of the resistors in the circuit with an OHM METER. Unit under test should be turned "OFF". Let the capacitors in the supply discharge before making any measurements.

STEP 3. Use an Oscilloscope and check for signal gain through each stage. Use the following as a guide line. (Use a ground lifting plug).

Expect gain from grid to plate.
Expect unite or a little loss from grid to cathode.
Expect gain from cathode to plate.

DC and AC RMS VOLTAGE TABLE

NOTE: The voltage table has DC and RMS AC measurements. The DC voltages listed in the table is the NOMINAL voltage based on 117/120 volts AC line. The VRMS is with an input signal of 1khz at -40dB (.02 vpp) and the Controls set to the following (Both Channels).

Preamp = 10 Bass = 10 Middle = 10 Treble = 0
 Presence = 0 O/D Master = 0
 Connect unit to a 8 ohm/100 watt load

Adjust the Master to "10" when needed.

Key: DC = DC voltage
 VRMS = AC signal using a FLUKE(c) Model 77
 Cl = Clean Channel
 O/D = Overdrive Channel

TUBE #		PIN NUMBERS											
12AX7													
	1		2		3		6		7		8		
	DC	VRMS	DC	VRMS	DC	VRMS	DC	VRMS	DC	VRMS	DC	VRMS	
V1	156	.4			1.2		222	5	0	.148	1.8		
V2	209	20			1.5		285	13			3.3		
V3	164	11			1.6		329				174	11	
V4	189	5			1.4		189	5			1.4		
V5	329				190	5	329				190		
V6	428	73			2.7		170	.05			1.2		
V7	213	22	22.6	2	34	2	204	25			34	2	

TUBE # PIN NUMBERS
 6L6

	3		4		5	
	DC	VRMS	DC	VRMS	DC	VRMS
V8	470	164	462		-50	
V9	470	164	462		-50	

PREAMP CIRCUITRY TUBE FUNCTION

V1a Input Buffer (clean and overdrive)

SYMPTOMS: Both channels noisy
Both channels dead
Microphonia whistling and squealing
Low volume
Lack of tonal color

V1b Preamp (clean)

SYMPTOMS: Clean channel noisy
Clean channel dead
Microphonia whistling and squealing Clean channel
Low volume Clean channel
Lack of tonal color Clean channel

V2a and V2b Overdrive gain stages

SYMPTOMS: Overdrive channel noisy
Overdrive channel dead
Low volume Overdrive channel
Lack of tonal color Overdrive channel

V3a Final preamp stage

SYMPTOMS: Both channels noisy
Both channels dead
Both channels low volume
Both channels lack of tonal color

V3b Output buffer for Effect Send

SYMPTOMS: Both channels noisy
Both channels dead
Both channels low volume
Both channels lack of tonal color

V4a Effect Return

SYMPTOMS: Both channels noisy
Both channels dead
Both channels low volume
Both channels lack of tonal color

V4b Reverb Mix

SYMPTOMS: Both channels noisy
Both channels dead
Both channels low volume
Both channels lack of tonal color

V6a Reverb Driver

SYMPTOMS: Reverb noisy
Reverb dead
Reverb low volume

V6b Reverb Return Preamp

SYMPTOMS: Reverb noisy
Reverb dead
Reverb low volume

V5a Clean Channel Tone driver

SYMPTOMS: Clean channel noisy
Clean channel dead
Clean channel volume low or controls have no effect

V5b Overdrive Channel Tone driver

SYMPTOMS: Overdrive channel noisy
Overdrive channel dead
Overdrive channel volume low or controls have no effect

V7a and V7b Phase Inverter

SYMPTOMS: Both channels noisy
Both channels dead
Low volume
Sounds distorted

V8 and V9 (2) 6L6 Power output tube (T50/T50C)

V8 – V11 (4) 6L6 Power output tube (T100/T100C)

SYMPTOMS: Low volume
Sounds distorted

BIAS ADJUSTMENT PROCEDURES WITH OSCILLOSCOPE

SET-UP: Before performing the Bias Adjustment.

1. 120 VAC 60Hz.
2. Output Impedance Switch 8 ohms
3. Unit connected to an 8 ohm load
4. Set ALL controls for the OVERDRIVE channel to "0"
5. Set controls to the following:

MASTER to "10"
MIDDLE to "10"
PRESENCE to "7"
ALL other controls to "0".

6. Input a .3 vpp 1kHz signal
7. Connect an Oscilloscope across the 8 ohm load

Step 1. Observe the oscilloscope and adjust the CLEAN PREAMP control to a level where the amplifier just starts to clip.

Step 2. Adjust the internal BIAS TRIMMER to eliminate all but a very slight amount of crossover distortion. There should be a slight bend in the wave shape, just barely noticeable.

This adjustment will insure the longest possible tube life.

BIAS ADJUSTMENT PROCEDURES WITH METER ONLY

SET-UP: No signal

Step 1. This measurement is taken from the ANODE of the bias diode (or across 47uf electrolytic capacitor) to ground.

Step 2. Adjust the internal BIAS TRIMMER so the voltage is approx -52 volts with NO signal applied to the input.

PRODUCTION UP-DATES

The following is a list of circuit up-date that has occurred. When ordering parts, please verify serial number.

1. The 1k ohms resistor on pin 8 of V6b was changed to a 1.8k ohms in models T50 and T100 Rack mountable Head.
2. The 1k ohms resistor on pin 8 of V6b was changed to a 1.8k ohms in models T50C and T100C after first production.
3. Lead configuration of the TREBLE potentiometer and the TONE PACK PWB mounting. The new TONE PACK is soldered directly to the TREBLE potentiometer. New parts are direct replacements.

Old
Part # T100POT1

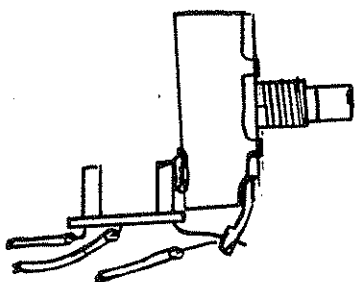

New
Part # T100POT1B

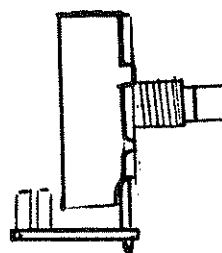

4. The mounting of REVERB DRIVE TRANSFORMER has been changed. The old type had leads exiting the transformer from it's side. The new type has leads exiting from the bottom.

R10Y
Part # T10050RT

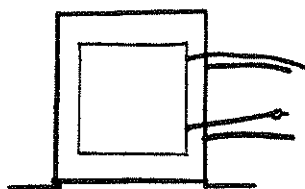

R10Y-1
Part # T10050RT-1

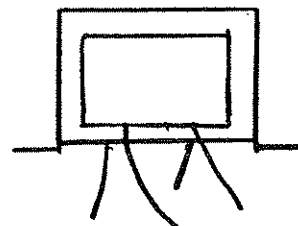

CIRCUIT BOARD LAYOUT FOR MODELS T00C AND T50C

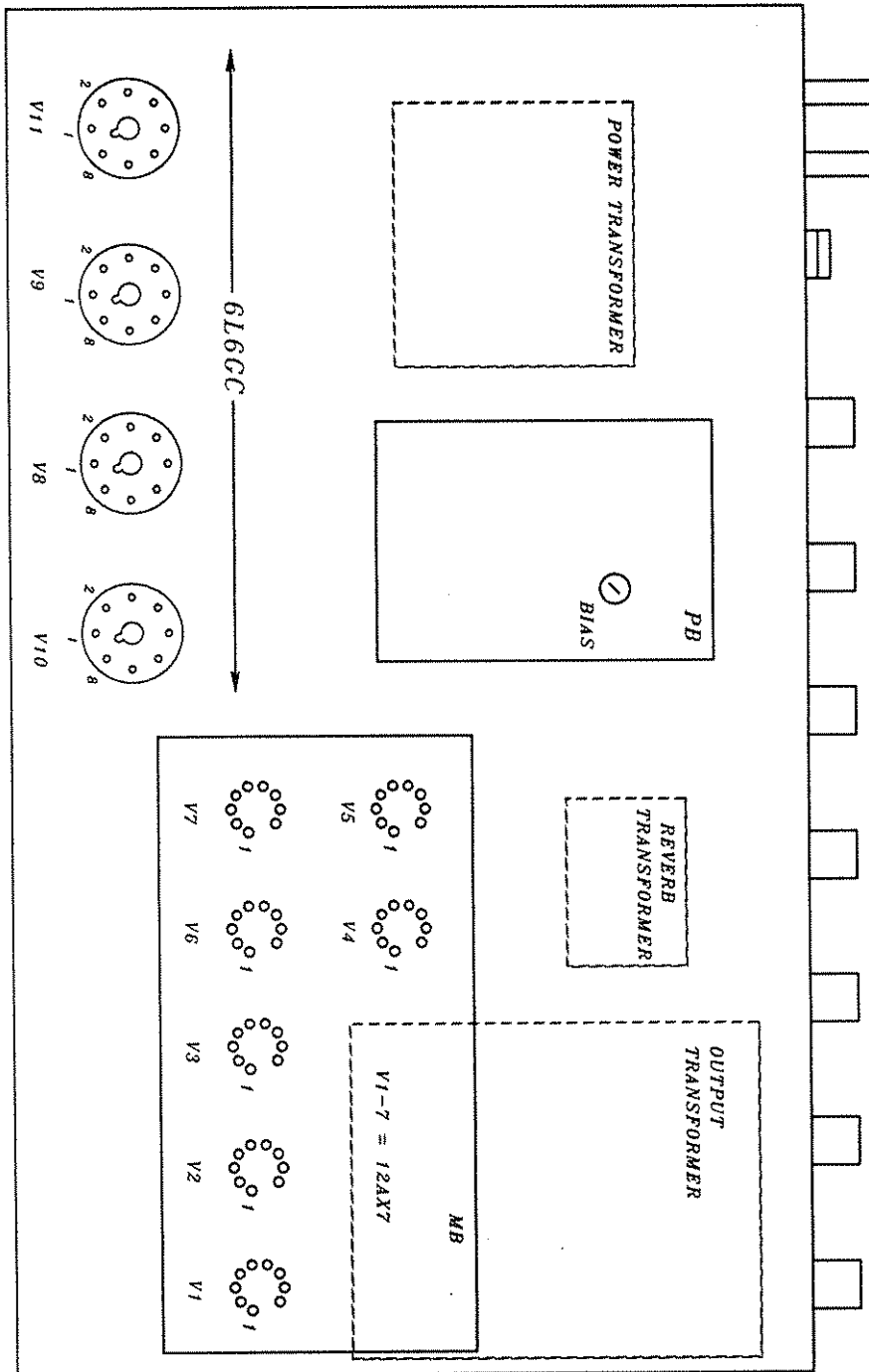

YAMAHA AMPLIFIER CHASSIS T100C - T50C

TOP VIEW

CIRCUIT BOARD LAYOUT FOR MODELS T100 AND T50

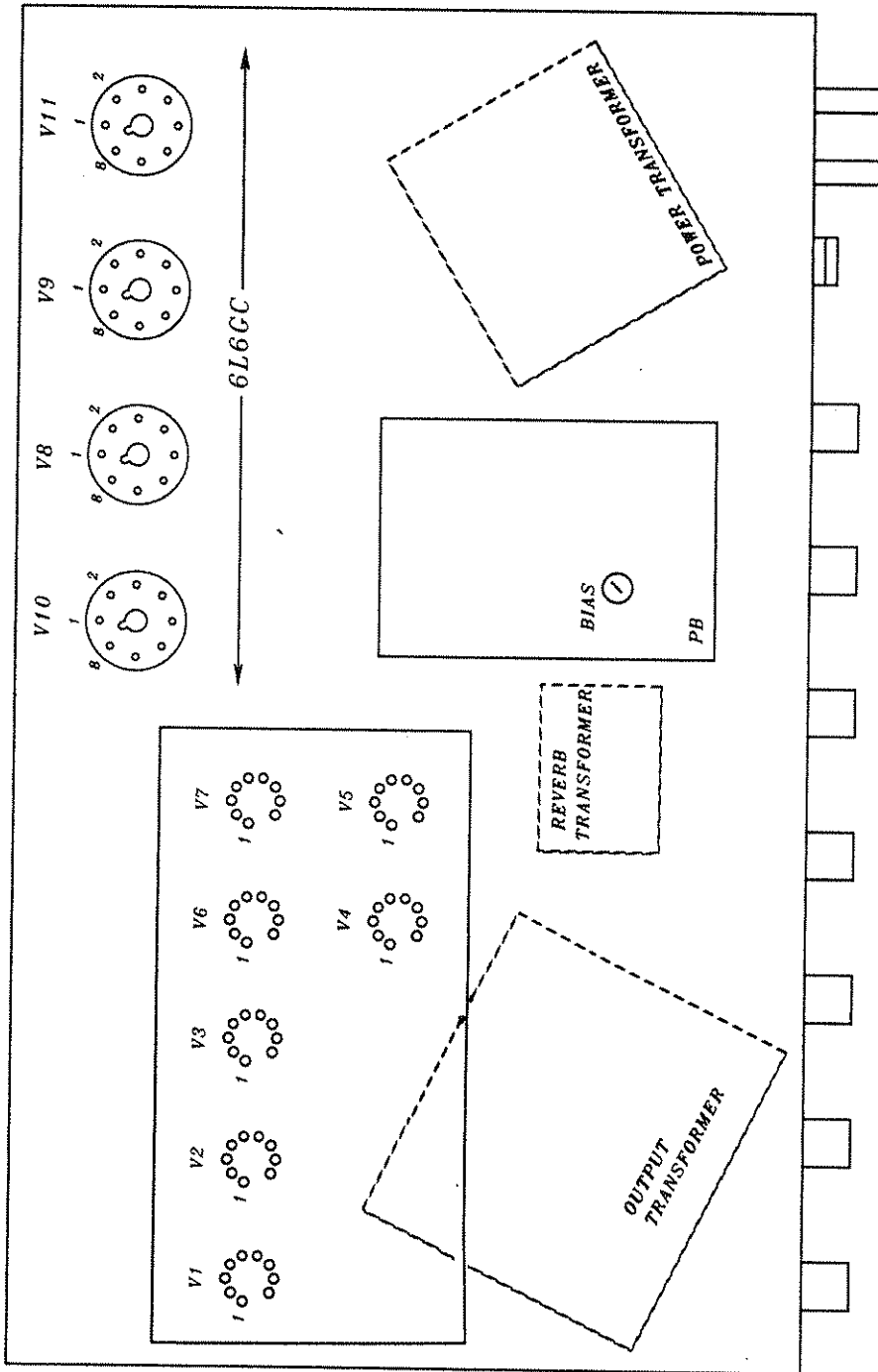

YAMAHA AMPLIFIER CHASSIS T100 - T50

BOTTOM VIEW

MB CIRCUIT BOARD

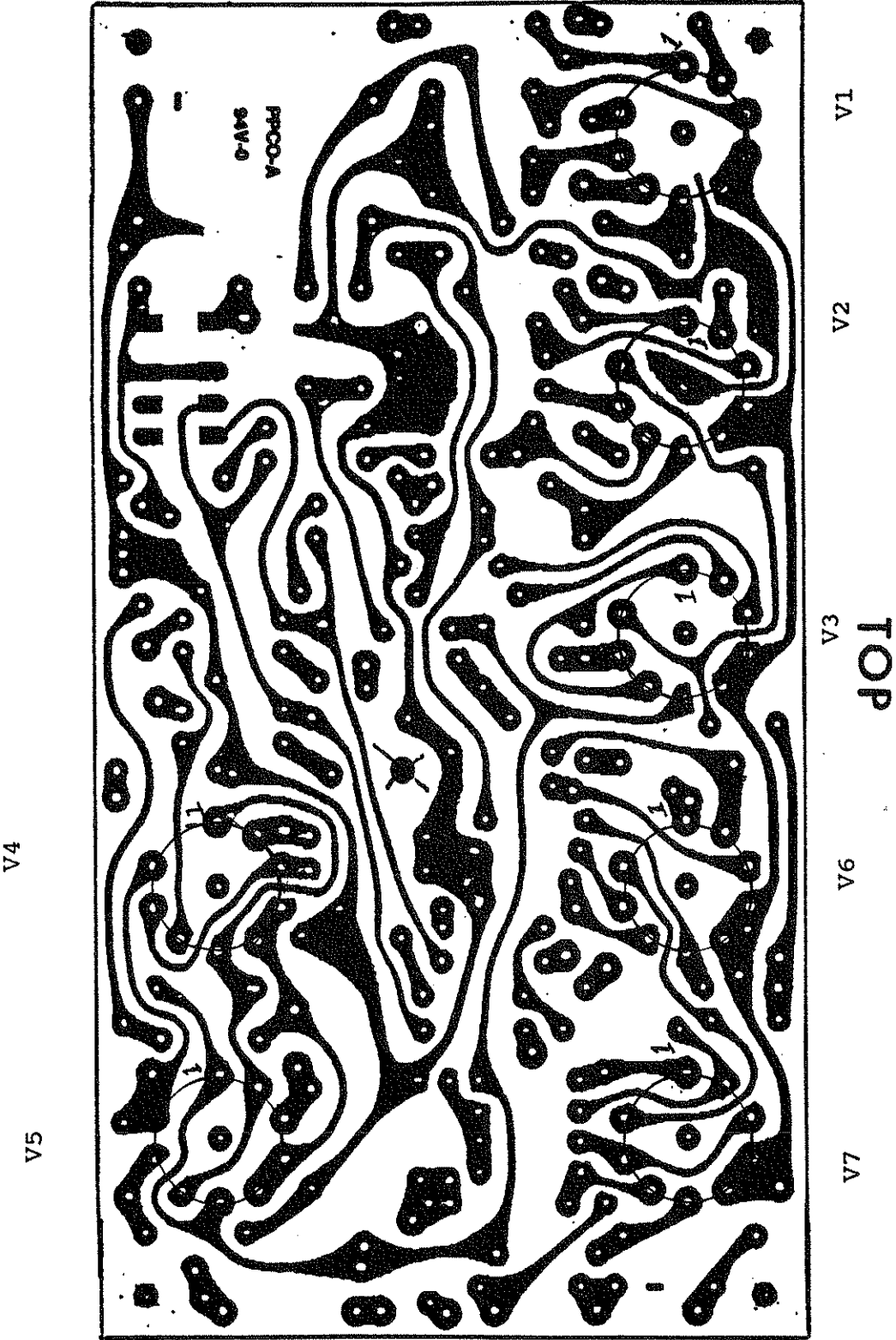

PB AND TONE CIRCUIT BOARD

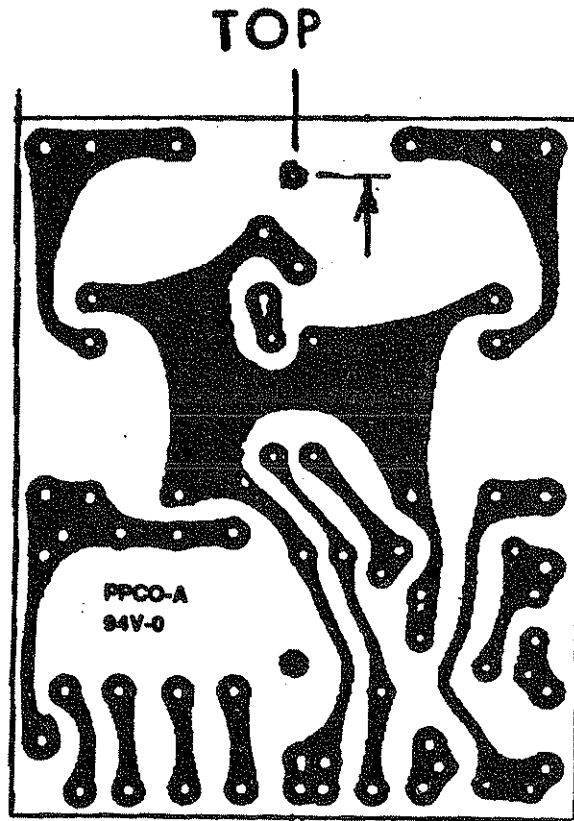

BLUE to MB BOARD (Clean Channel)
GREEN to MB Board (O/D Channel)

WHITE to MIDDLE CONTROL

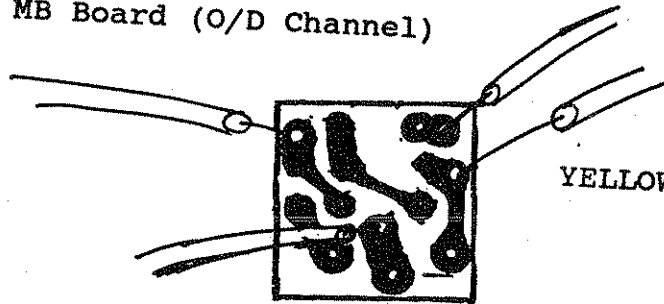

YELLOW to BASS CONTROL

WHITE to MASTER CONTROL

TONE CONTROL PWB

VACUUM TUBE AMPLIFIER BLOCK DIAGRAM

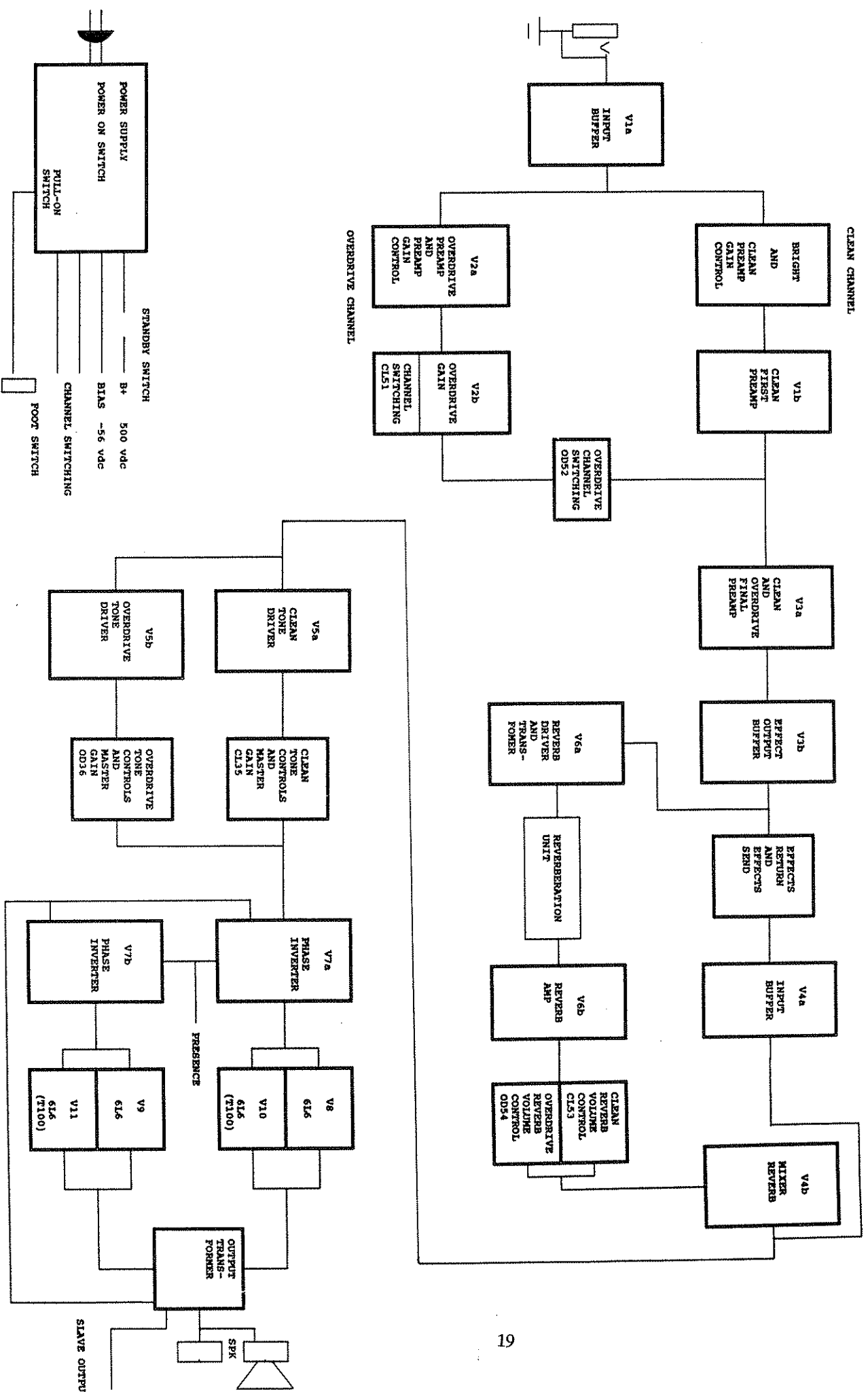

SCHEMATIC Part 1 OF 3

POWER SUPPLY T50-100

YAMAHA

MONITOR THE OUTPUT WITH AN OSCILLOSCOPE.
BIAS TRIM - ADJUST FOR MINIMUM CROSSEVER DISTORTION
AT MAXIMUM POWER OUTPUT.

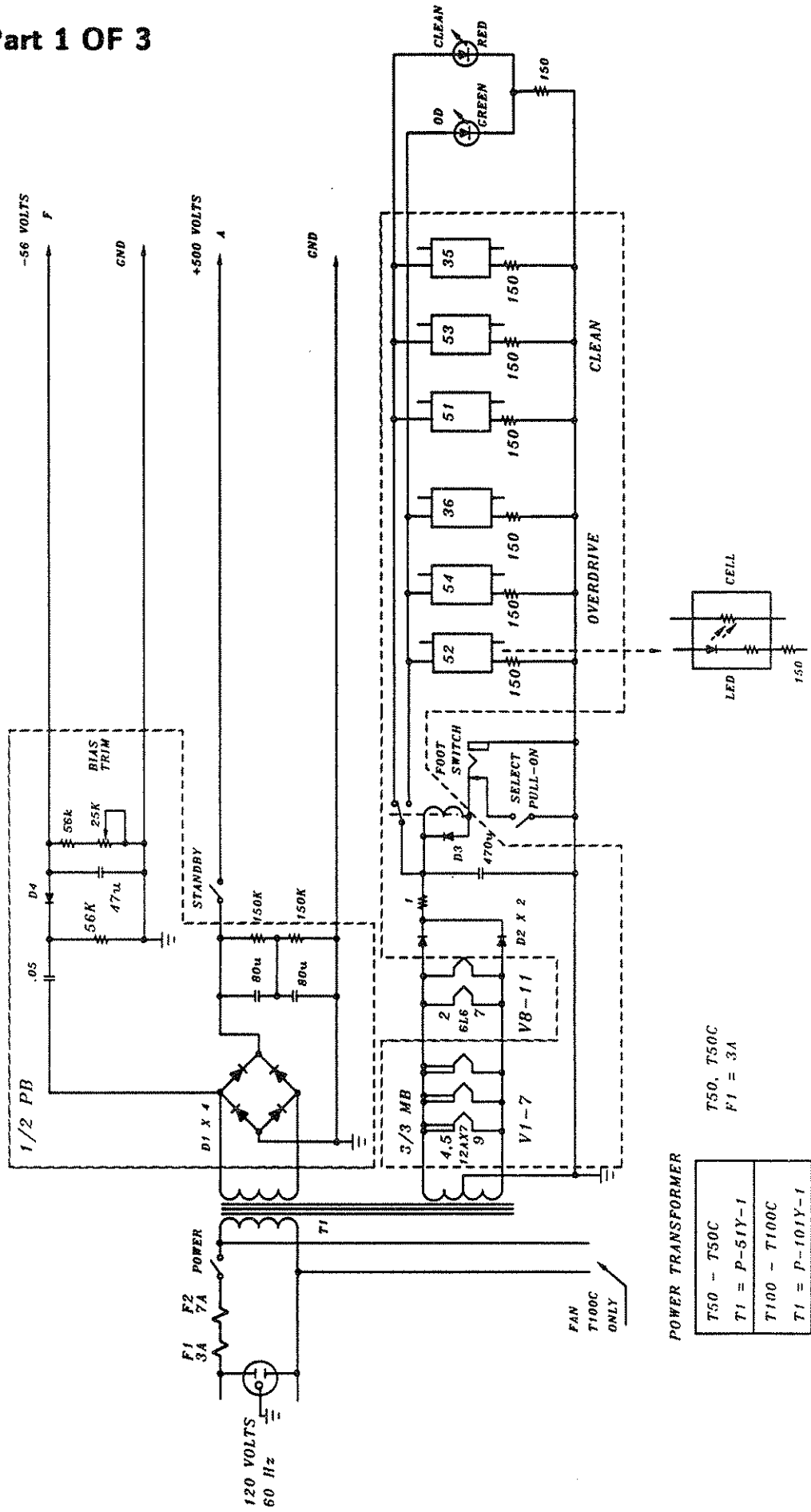

POWER TRANSFORMER

T50 - T50C
T1 = P-51Y-1
T100 - T100C
T1 = P-101Y-1

T50, T50C
F1 = 3A

SCHEMATIC PART 2 OF 3

YAMAHA

PRE-AMPLIFIER SECTION

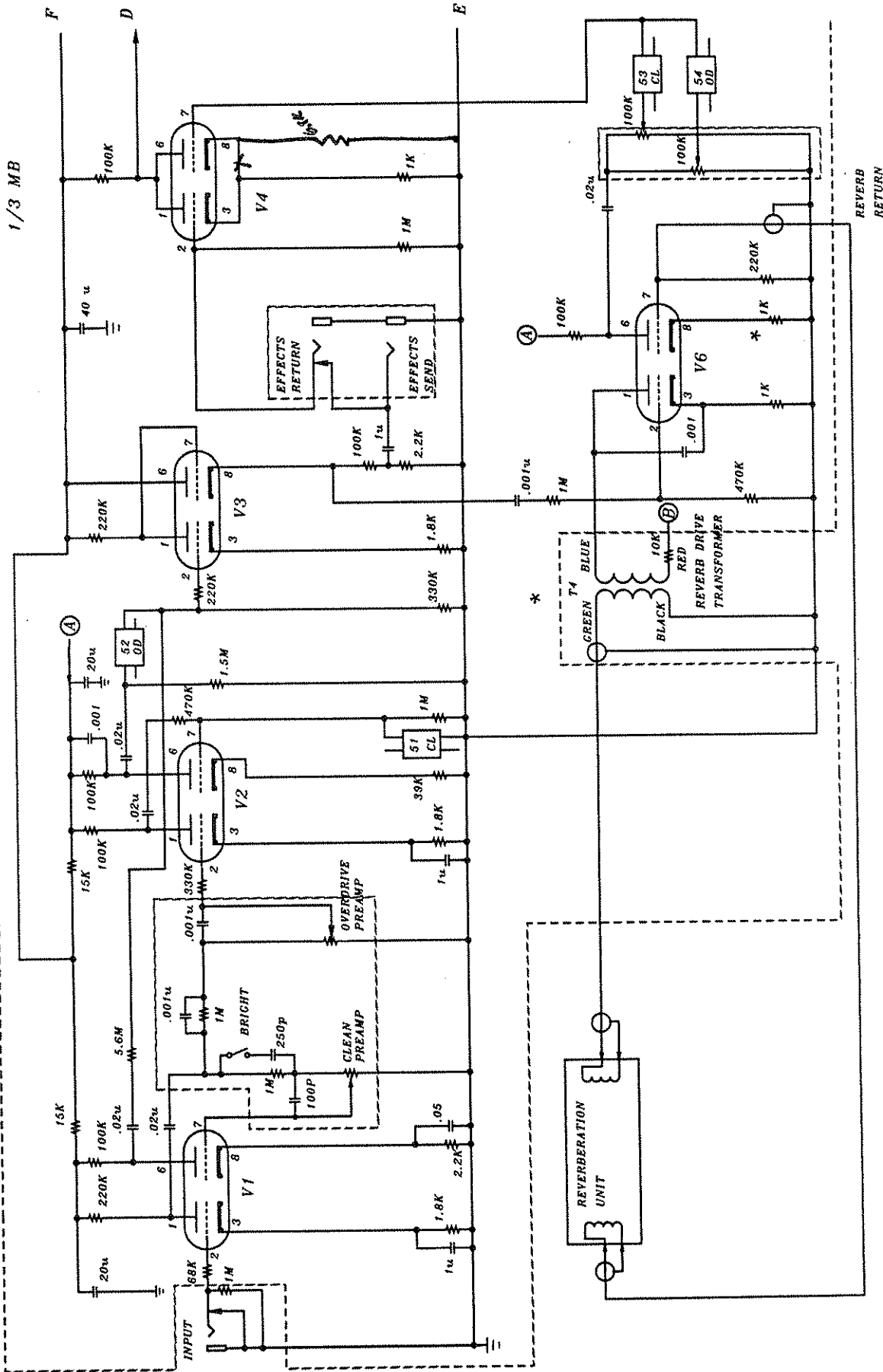

* Please read Production up-dates page 14

V1 - 6 = 12AX7

SCHEMATIC PART 3 OF 3

YAMAHA

POWER AMPLIFIER SECTION

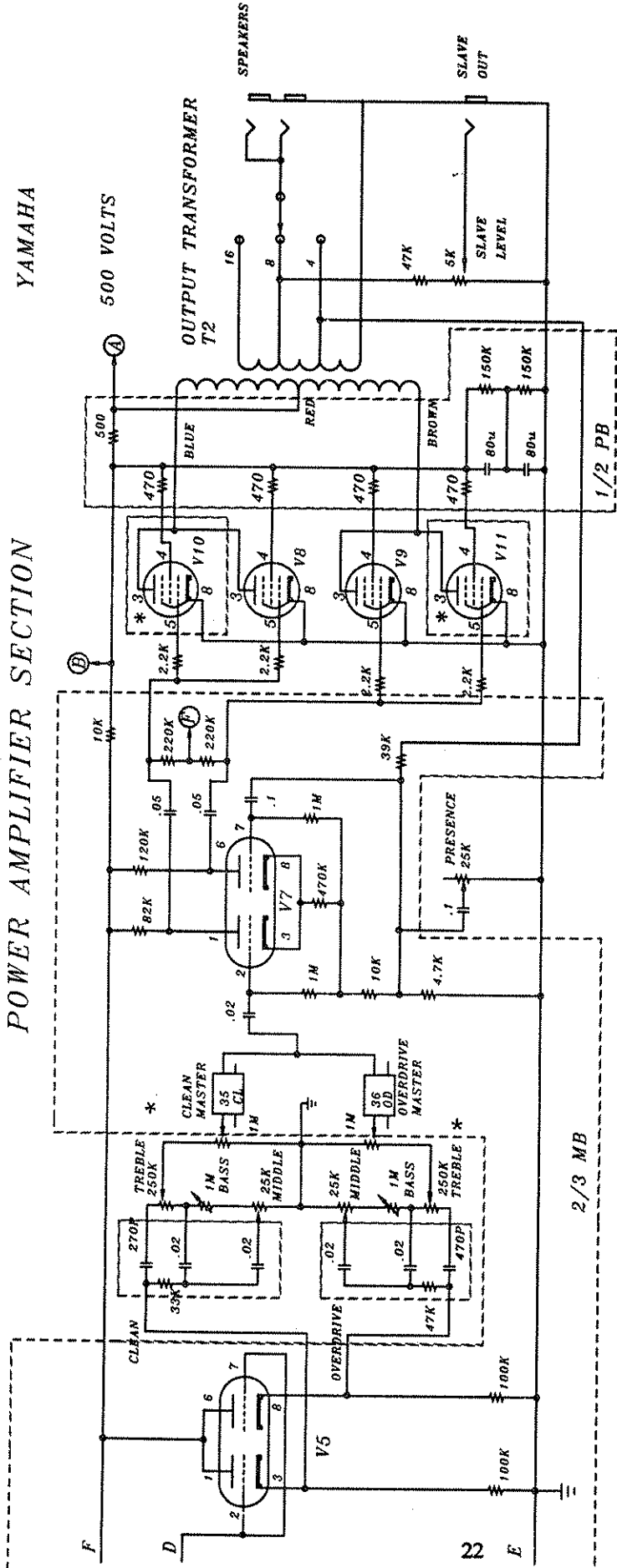

* - T100 ONLY

* Please read Production up-dates page 14

THE DC VOLTAGE LISTED IN THE TABLE IS THE NOMINAL DC VOLTAGE FOR THAT PIN BASED ON 117 VOLTS AC LINE.

ALL VOLTAGE IS MEASURED WITH RESPECT TO POWER GROUND

PIN NUMBERS

TUBE #	1	2	3	4	5	6	7	8	9
V1	156		1.2			222		1.8	
V2	209		1.5			285		3.3	
V3	164		1.6			329		3.3	
V4	189		1.4			189		1.4	
V5	329		190			329		190	
V6	428		2.7			170		1.2	
V7	213		34			204		34	
V8			470	462	-50			0	
V9			470	462	-50			0	

T2 - OUTPUT TRANSFORMER
 T50-T50C = 0-51Y-1
 T100-T100C = 0-101Y-1

V5 - 7 = 12AX7
 V8, 9 = 6L6CC
 V10, 11 = 6L6CC T100 ONLY

THIS PAGE HAS INTENTIONLLY LEFT BLANK

**T SERIES VACUUM TUBE AMPLIFIERS
PARTS LIST**

YAMAHA ELECTRONIC SERVICE PARTS LIST

MODEL NAME: T50C/T100C T-SERIES VACUUM TUBE AMPLIFIER
50W AND 100W TUBE AMP COMBO

ITEM#	PART NO.	PART DESCRIPTION	NOTE	
1.	NCY81370	CABINET		
2.	DAY83040	BAFFLE ASSY W/GRILLE	CLOTH & SCREWS	
3.	EKY00720	HEX SCREW #10-32 X 1-3/4	BAFFLE BD	
4.	EKY00730	#10 PLAIN WASHER BL	BAFFLE BOARD	
5.	EFAI2030	FHSMS #8 X 1 1/4 BL	BCK BD STRIP	
6.	EWFI0030	FINISHING WASHER #8	BCK BD STRIP	
7.	DAY83050	BACK BOARD STRIP	2 PER W/VINYLY	
8.	EKY00340	PHMS #10-32 X 1-1/2	AMP, TOP BOARD	
9.	EWPK0030	#10 PLAIN WASHER BL	AMP-TOP BOARD	
10.	AAAY01180	STRAP HANDLE ASSY	2 PER UNIT	
11.	CBY01900	STRAP HANDLE	BLACK	
12.	AAAY01200	STRAP HANDLE INSERT		
13.	EKY00870	OHMS #10-32 X 1 NK	2 PER - HANDLE	
14.	NBY03120	100 WATT AMP	T100C ONLY	
15.	NBY03100	50 WATT AMP	T50C ONLY	
16.	JHY00050	REVERB	9AB2B1B	
17.	CBY01930	REVERB BAG - SLIT LENGTHWISE		
18.	EPAG0830	PHSMS #6 X 1/2 BL	6 PER REVERB BAG	
19.	EWPI0030	#8 PLAIN WASHER BL	REVERB BAG	
20.	AAAY01190	CORNER PROTECTOR	6 PER - SILVER	
21.	EOAI1250	OHSMS #8 X 3/4	12 PER-CORNER	
22.	CBY01920	TUNING FORK LOGO		
23.	EFAG0830	FHSMS #6 X 1/2 BL	2 PER - LOGO	
24.	CBY01890	RUBBER FOOT	4 PER UNIT	
25.	ETAI1230	THSMS #8 X 3/4 BL	4 PER - FOOT	

YAMAHA ELECTRONIC SERVICE PARTS LIST

MODEL NAME: T50C/T100C T-SERIES VACUUM TUBE AMPLIFIER
50W AND 100W TUBE AMP COMBO

ITEM#	PART NO.	PART DESCRIPTION	NOTE	
26.	JAY50800	WOOFER	T100C ONLY	
27.	JAY50700	WOOFER	T50C ONLY	
28.	ENPI0010	PAL NUT #8-32	4 PER - WOOFER	
29.	MIY00150	SPKR WIRE 12" W/HEAT	SHIELD W/PLUG	
30.	AAY01240	FAN	T100C ONLY	
31.	AAY01250	BRACKET FOR FAN	2 PER UNIT	
32.	EPAI1030	PHMS #8 X 5/8 2 PER	FAN BRACKET	
33.	AAY01260	FINGER GUARD	ON FAN	
34.	EPMI3230	PHMS #8-32 X 2 BL 4	PER-FINGERGRD	
35.	AAY01210	SHIELD SHEET 7 X 17	SELF-ADHESIVE	
36.	PBY00060	FOOT SWITCH ASSY		
37.	MIY00140	FOOT SWITCH CABLE		
38.	T10050RT	REVERB DRV. XFORMER	R10Y (SER#'S)	
39.	T10050RT-1	REVERB DRV. XFORMER	R10Y-1(SER#'S)	
40.	T50000PT	T50C POWER XFORMER	P51Y-1	
41.	T50000OT	T50C OUTPUT XFORMER	O51Y-1	
42.	T10000PT	T100C POWER XFORMER	P101Y-1	
43.	T10000OT	T100C OUTPUT XFORMER	O101Y-1	
44.	T1005PCC	POWER CORD	MIY00160	
45.	T10050KN	KNOB	13 PER UNIT	
46.	T100POT5	POT.5K LINEAR	SLAVE LEVEL	
47.	T100POT6	POT.500K W/SWITCH	PREAMP/BRIGHT	
48.	T100POT4	POT.100K LINEAR	REVERB	
49.	T100POT1	POT.250K LINEAR	TREBLE SER#	
50.	T100POT1B	POT.250K LINEAR W/TONE	PK TRBL SER#	

YAMAHA ELECTRONIC SERVICE PARTS LIST

MODEL NAME: T50C/T100C T-SERIES VACUUM TUBE AMPLIFIERS
50W AND 100W TUBE AMP COMBO

ITEM#	PART NO.	PART DESCRIPTION	NOTE	
51.	T100POT2	POT. 1 MEG LOG.	BASS/MASTER	
52.	T100POT3	POT.25K LINEAR	MID/PRESENCE	
53.	T10050FH	FUSE HOLDER ASSY		
54.	T100TUB8	TUBE SOCKET	8 PIN OCTAL	
55.	T100TUB9	TUBE SOCKET - PC MOUNT 9 PIN		
56.	T10050PH	PHOTOCELL	VALTEC - VTL5C1	
57.	T10050RS	RELAY SWITCH	CHANNEL SELECT	
58.	T10050PS	POWER SWITCH	POWER STANDBY	
59.	T1PRETUB	PREAMP TUBE	12AX7	
60.	T1POWTUB	POWER TUBE	6L6GC	
61.				
62.				
63.				
64.				
65.				
66.				
67.				
68.				
69.				
70.				
71.				
72.				
73.				
74.				
75.				

YAMAHA ELECTRONIC SERVICE PARTS LIST

MODEL NAME: T50/T100 T-SERIES VACUUM TUBE AMPLIFIER
50W AND 100W TUBE AMP HEAD

ITEM#	PART NO.	PART DESCRIPTION	NOTE	
1.	NCY81380	CABINET		
2.	DAY83030	BACK BOARD STRIP	2 PER W/VINYL	
3.	EFAI2030	FHSMS #8 X 1 1/4 BL	BCK BD STRIP	
4.	EWFI0030	FINISHING WASHER #8	BCK BD STRIP	
5.	AA01180	STRAP HANDLE BRACKET	2 PER UNIT	
6.	CBY01900	STRAP HANDLE	BLACK	
7.	AA01200	STRAP HANDLE INSERT		
8.	EKY00870	OHMS #10-32 X 1 NK	2 PER - HANDLE	
9.	NBY03110	100 WATT AMP	T100 ONLY	
10.	NBY03090	50 WATT AMP	T50 ONLY	
11.	CBY01910	PLASTIC WASHER #10	AMP, FRONT	
12.	EKY00340	PHMS #10-32 X 1-1/2	AMP, BTM, FRONT	
13.	AA01190	CORNER PROTECTOR	8 PER - SILVER	
14.	EOAI1250	OHSMS #8 X 3/4	16 PER -CORNER	
15.	CBY01890	RUBBER FOOT	4 PER UNIT	
16.	ETAI1230	THSMS #8 X 3/4 BL	4 PER - FOOT	
17.	AA01230	RADIATION GRILLE	TOP OF UNIT	
18.	EPAG1230	PHSMS #6 X 3/4 BL-RADIATION GRILLE		
19.	JHY00060	REVERB ASSY	#8AB3D1B	
20.	PBY00060	FOOT SWITCH ASSY		
21.	MIY00140	FOOT SWITCH CABLE		
22.	T1005PCR	POWER CORD	MIY00190	
23.	T10050RT	REVERB DRV. XFORMER	R10Y (SER#'S)	
24.	T10050RT-1	REVERB DRV. XFORMER	R10Y-1(SER#'S)	
25.	T50000PT	T50 POWER XFORMER	P51Y-1	

YAMAHA ELECTRONIC SERVICE PARTS LIST

MODEL NAME: T50/T100 T-SERIES VACUUM TUBE AMPLIFIER
50W AND 100W TUBE AMP HEAD

ITEM#	PART NO.	PART DESCRIPTION	NOTE	
26.	T500000T	T50 OUTPUT XFORMER	O51Y-1	
27.	T10000PT	T100 POWER XFORMER	P101Y-1	
28.	T100000T	T100 OUTPUT XFORMER	O101Y-1	
29.	T10050KN	KNOB	13 PER UNIT	
30.	T100POT5	POT.5K LINEAR	SLAVE LEVEL	
31.	T100POT6	POT.500K W/SWITCH	PREAMP/BRIGHT	
32.	T100POT4	POT.100K LINEAR	REVERB	
33.	T100POT1	POT.250K LINEAR	TREBLE SER#	
34.	T100POT1B	POT.250K LINEAR W/TONE PK TRBL	SER#	
35.	T100POT2	POT.1 MEG LOG.	BASS/MASTER	
36.	T100POT3	POT.25K LINEAR	MID/PRESENCE	
37.	T10050FH	FUSE HOLDER ASSY		
38.	T100TUB8	TUBE SOCKET	8 PIN OCTAL	
39.	T100TUB9	TUBE SOCKET - PC MOUNT	9 PIN	
40.	T10050PH	PHOTOCELL	VALTEC - VTL5C1	
41.	T10050RS	RELAY SWITCH	CHANNEL SELECT	
42.	T10050PS	POWER SWITCH	POWER STANDBY	
43.	T1PRETUB	PREAMP TUBE	12AX7	
44.	T1POWTUB	POWER TUBE	6L6GC	
45.				
46.				
47.				
49.				
50.				

Yamaha Corporation of America
Electronic Service Division

T50/100
GUITAR AMPLIFIER
REVERB WASH MODIFICATION

Please read through these instructions before proceeding with this modification.

OVERVIEW

When the Overdrive channel (with reverb On) is being played, and a change is made to the Clean channel, a noise is created in the reverb drive circuit. This modification will reduce the "effect return from loading the reverb return", while providing better current gain, through isolation of amplifier stage "V4." The two (2) plates and two (2) cathodes on Amp stage "V4" will be isolated. Five (5) components will be added, and three (3) circuit traces must be opened (cut).

COMPONENTS NEEDED FOR THIS MODIFICATION

The parts needed for this modification are listed below. A parts modification kit is available from the Yamaha Electronic Service Parts Department. Please use the part number provided if additional kits are needed. Part # T50/100 KIT.

1. (1) 6.8K ohm @ 1/2 watt
2. (1) 100K ohm @ 1/2 watt
3. (1) 470K ohm @ 1/2 watt
4. (1) 220K ohm @ 1/2 watt
5. (1) .0047 or .005mfd. @ 250 volts (minimum voltage rating)

BILLING PROCESS

Billing for this modification should be done through YAMAHA CORPORATION of AMERICA, Electronic Service Division. Please use the standard warranty claim form for reimbursement. Yamaha will reimburse the Labor (up to one hour) at the standard warranty labor rate.

GAINING ACCESS TO THE INSIDE

CABINET UNIT (refer to figure 1)

Remove the four (4) phillips-head screws on the top of the cabinet. The chassis may not clear the metal corners, therefore, they may have to be taken off. The reverb cables may have to be unplugged from the reverb spring pan, (located on the bottom of the cabinet) in order for the chassis to be removed from the cabinet.

RACK-MOUNT UNIT (refer to figure 2)

Remove the two (2) phillips-head screws located on the bottom of the amplifier cabinet and the four (4) phillips-head screws on the front panel. It may be necessary to remove the metal corner covers, which may prevent removal of the chassis. First, try sliding the chassis out toward the front, if it clears, the corners need not be removed.

PERFORMING THE MODIFICATION

Figure 3 is the circuit diagram of the non-modified amp (V4), and Figure 4 illustrates the amplifier diagram, after the modification. A circuit diagram and tube layout are include in the back of this information.

1. The Plates and Cathodes of amplifier stage "V4" must be isolated as illustrated.
2. Currently Pins 1 and 6 are connected directly together, and Pins 3 and 8 are connected directly together.
3. Individual plate and cathode resistors are necessary for each amplifier stage (V4). The connecting foil between Pins 3 and 8 must be cut (see figures 5 and 6). Install one end of a 6.8K ohm resistor to Pin 8 of V4 amplifier stage (see figure 6A). Connect the other end of the resistor to ground. The 1K ohm resistor on pin 3 will remain in the circuit without any change.
4. The foil between Pins 1 and 6 on V4 must also be cut (see circuit board comparison figures 5, 6). The last foil that must be cut or opened, is between V4 pin 6, and V5 pin 2. Individual plate resistors (100K ohm) are to be used on Pins 1 and 6. The existing 100K ohm resistor that is connected to Pin 6 will remain as is.
5. Add a 100K ohm resistor to Pin 1 of amplifier stage V4, and connect the other end of the resistor to B+. Add a jumper wire from Pin 1 (V4) and connect the other end of the wire to Pin 2 of amplifier stage V5.
6. Next, connect one end of the .0047mfd capacitor to Pin 6 on amplifier stage V4. On the other end of the capacitor, connect one end of the 470K ohm resistor. Now, locate tube V7, pin 2. You will find one end of a .02mfd capacitor soldered at this point. Next, unsolder the opposite end of the .02mfd capacitor. Solder one end of the 220K ohm resistor to the circuit trace the cap was removed from. On the other end of the 220K ohm, connect both the .02mfd cap and the other end of the 470K ohm resistor that was added.
7. If distortion is detected in the Reverb signal only, then replace the 1K ohm cathode resistor with a 2k ohm resistor on amplifer stage V6. This resistor is connected from pin 3 to ground.
8. Verify all work before testing the operation after modification.

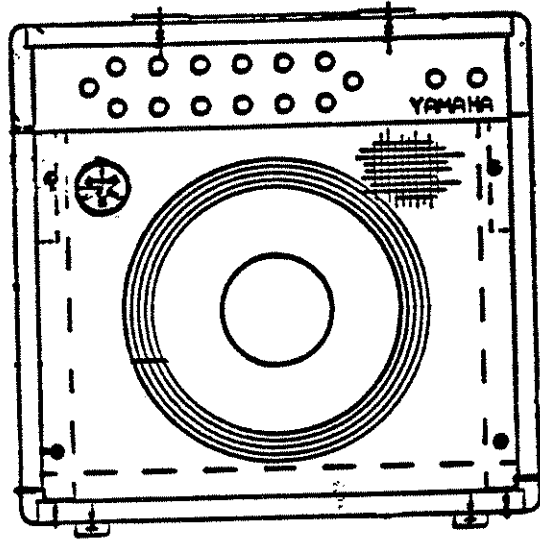
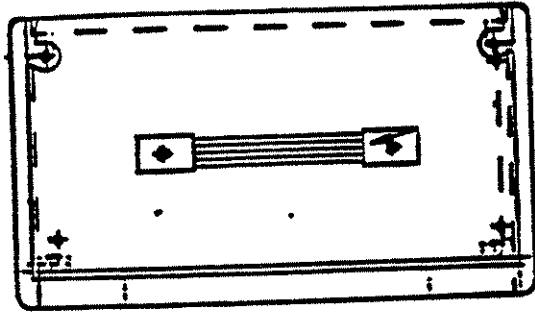

FIGURE 1

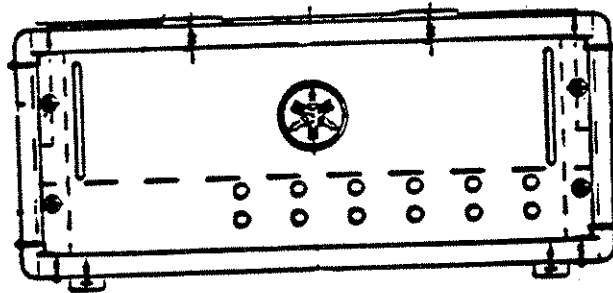
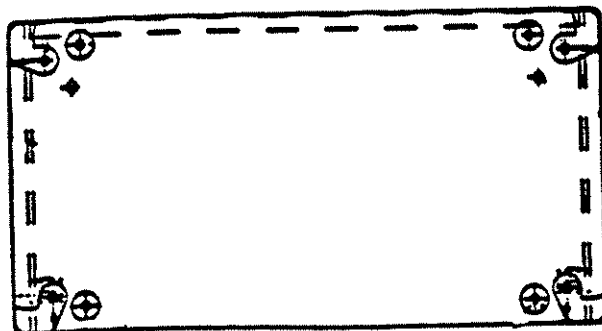

FIGURE 2



Before Modification.

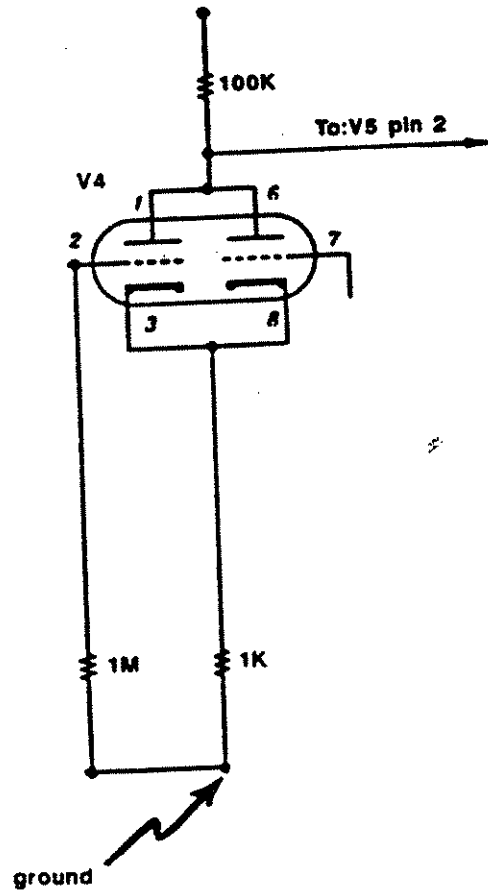
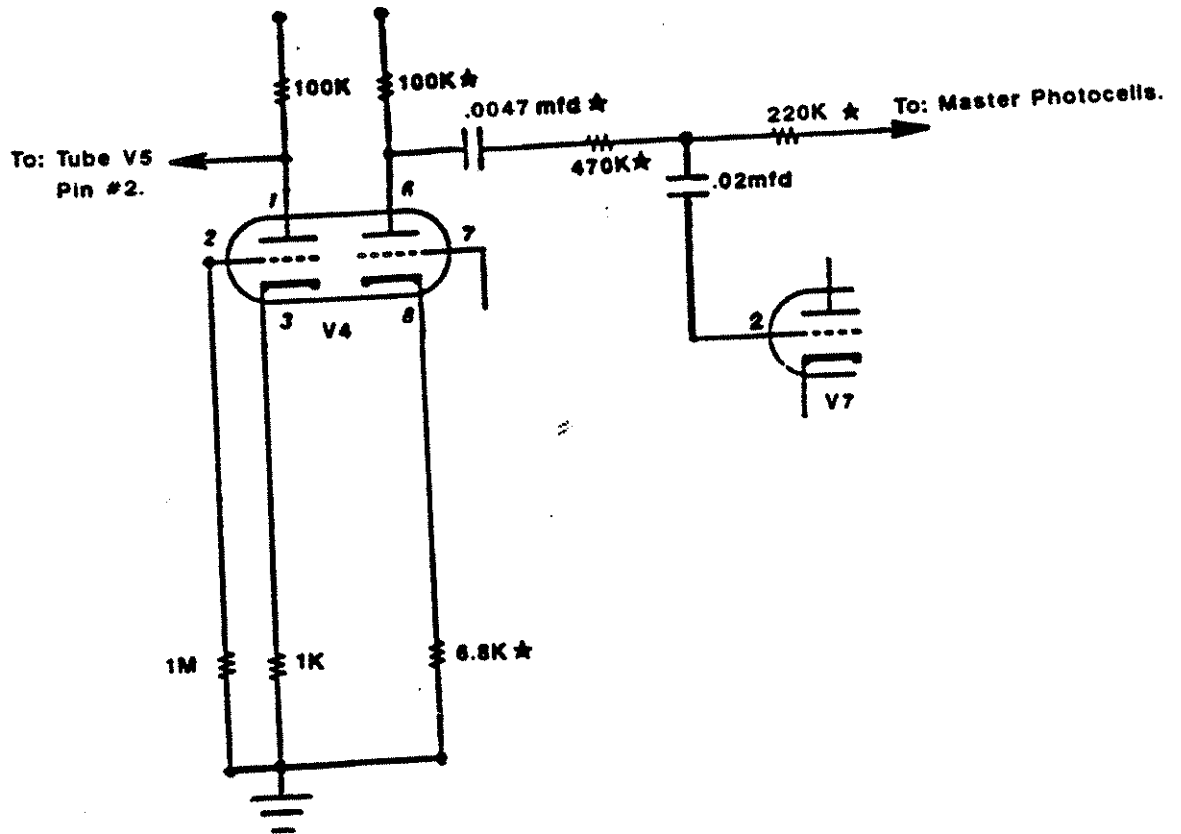

FIGURE 3

FIGURE 4

After Modification.



★ Parts added.

Before Modification.

FIGURE 5

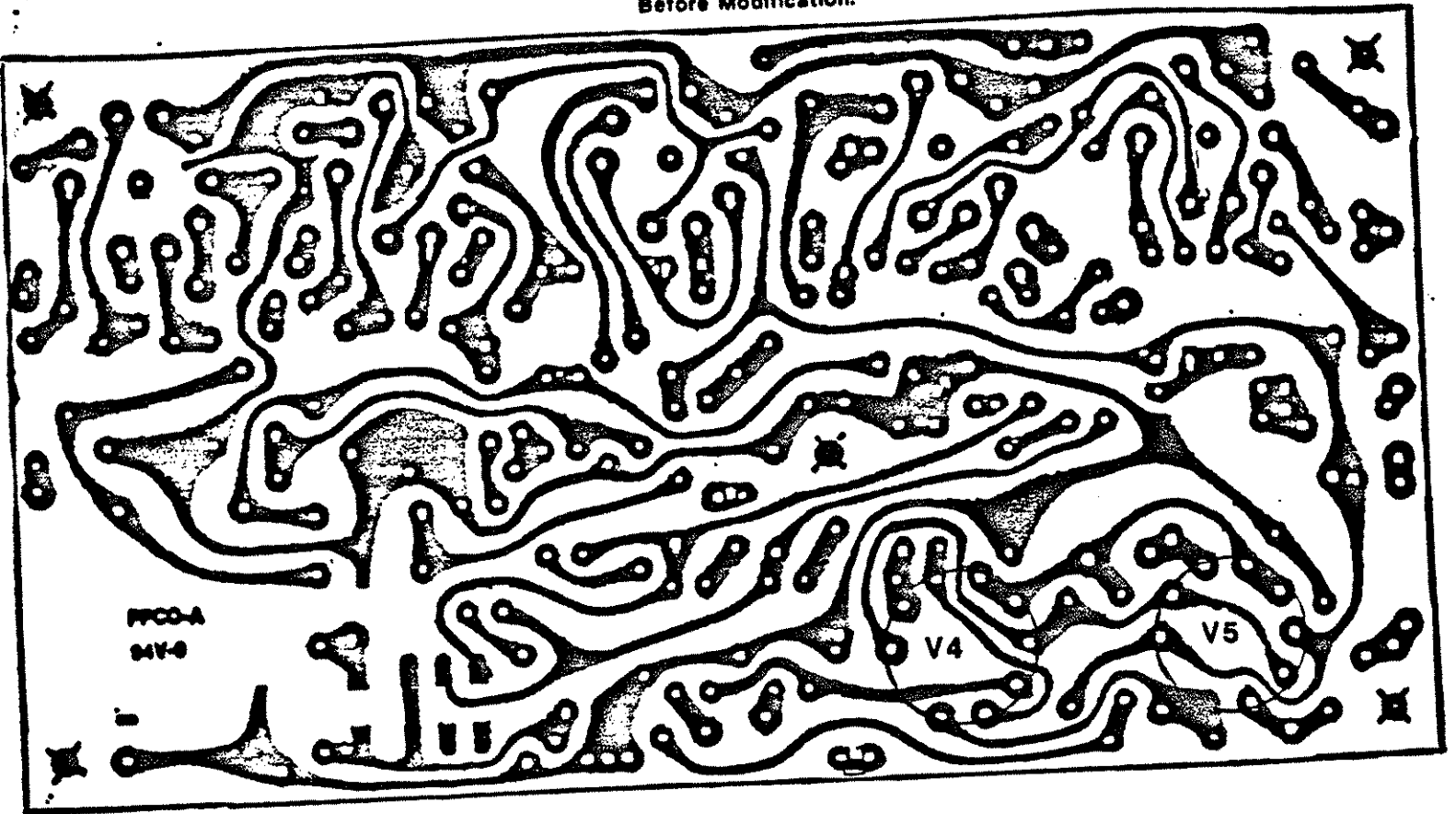

After Modification.

FIGURE 6

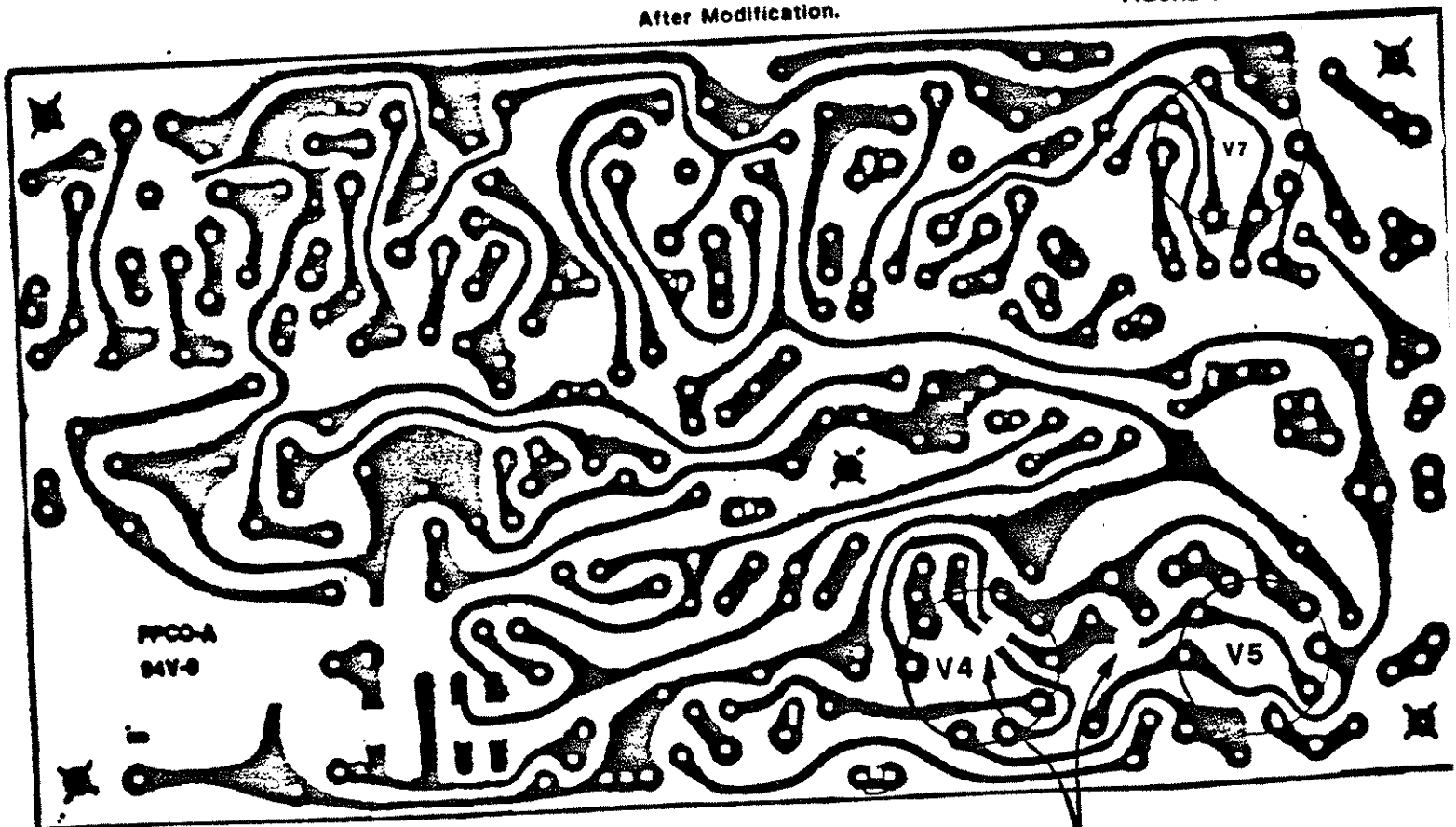

CUT FOIL AS SHOWN.

YAMAHA

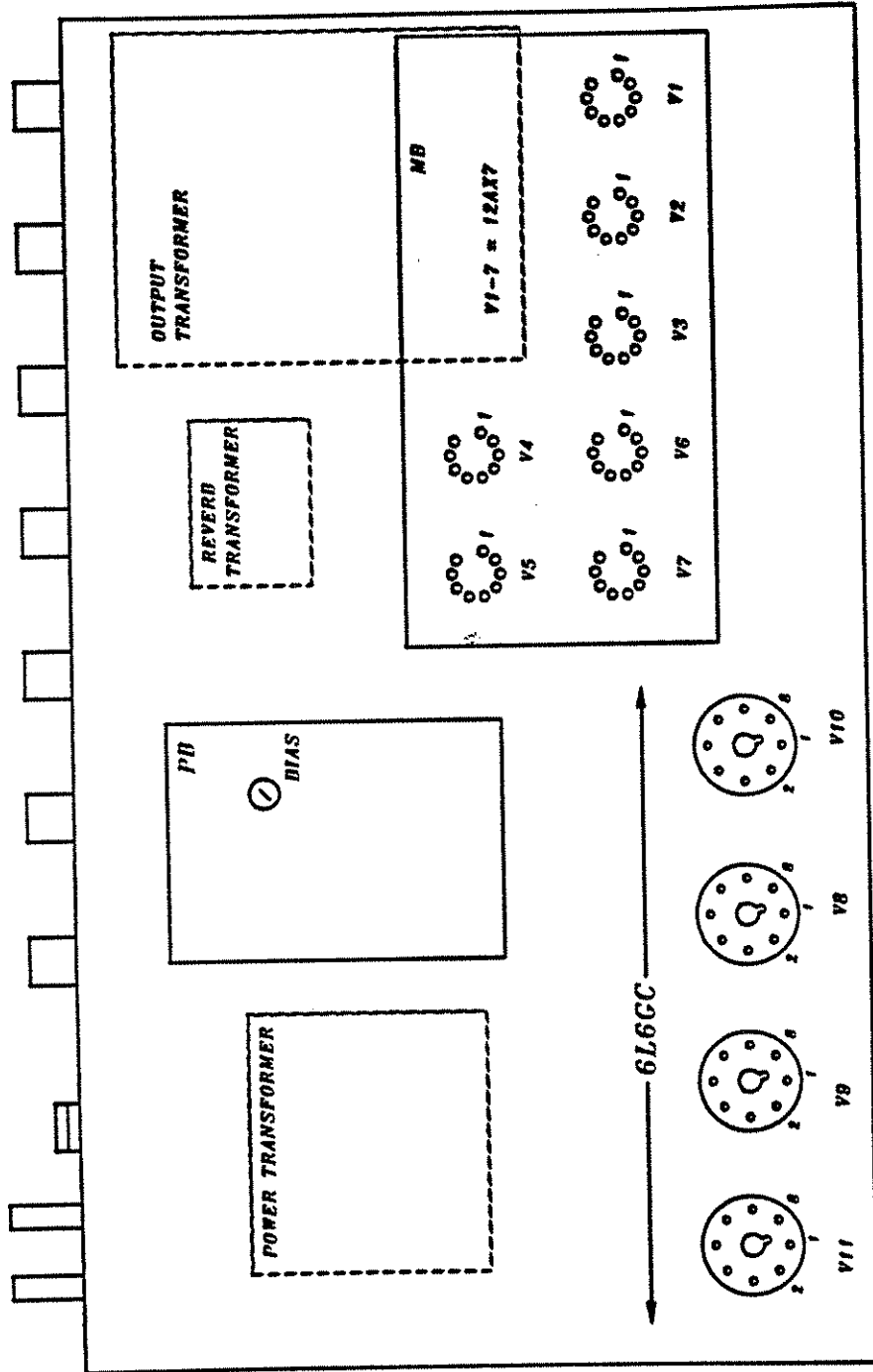

TUBE AMPLIFIER CHASSIS - TOP VIEW

T50C/T100C

YAMAHA
POWER SUPPLY
T50-100

MONITOR THE OUTPUT WITH AN OSCILLOSCOPE.
BIAS TRIM - ADJUST FOR MINIMUM CROSSOVER DISTORTION
AT MAXIMUM POWER OUTPUT.

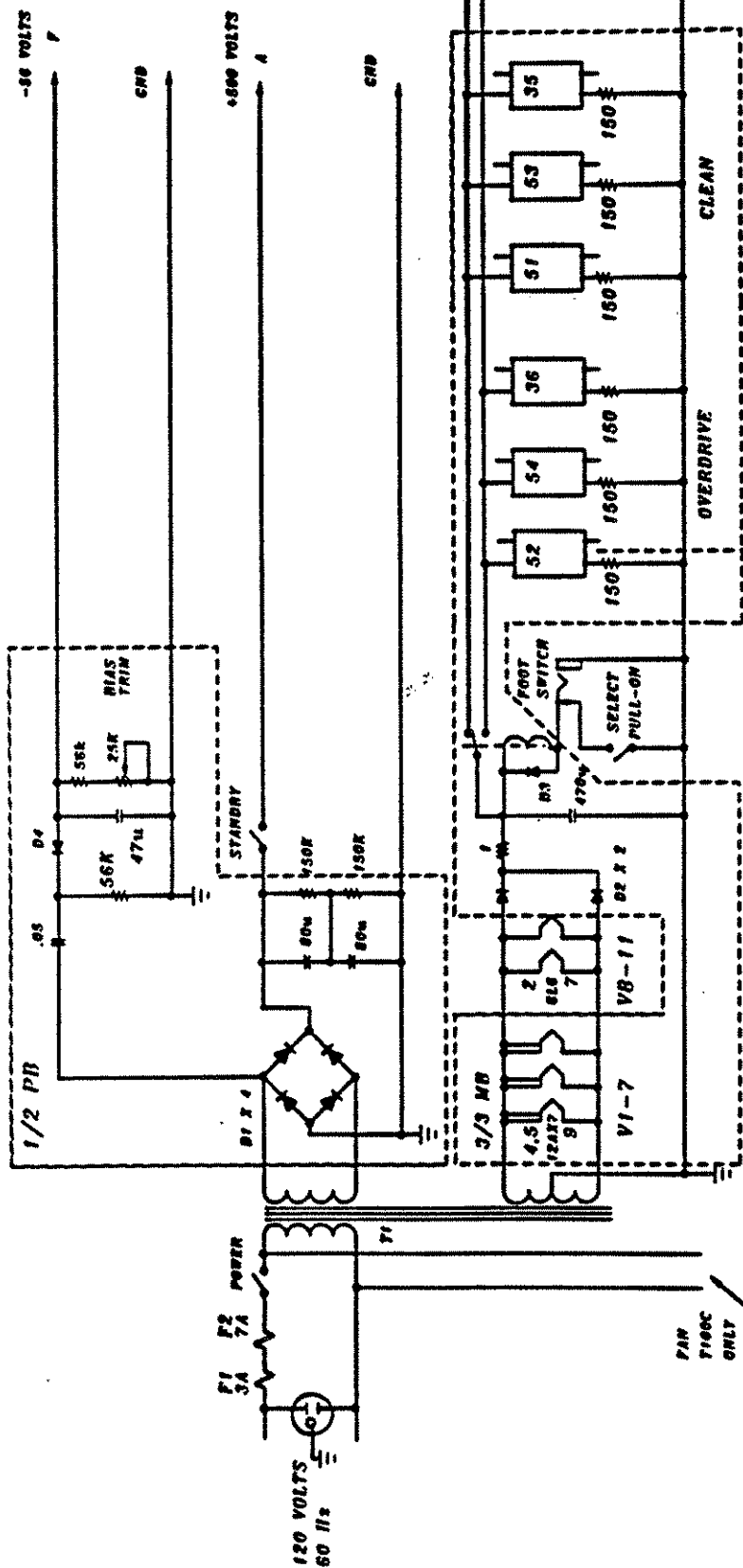

POWER TRANSFORMER

T50 - T50C
T1 = P-51Y-1
T100 - T100C
T1 = P-101Y-1

T50, T50C
F1 = 3A

YAMAHA
POWER AMPLIFIER SECTION

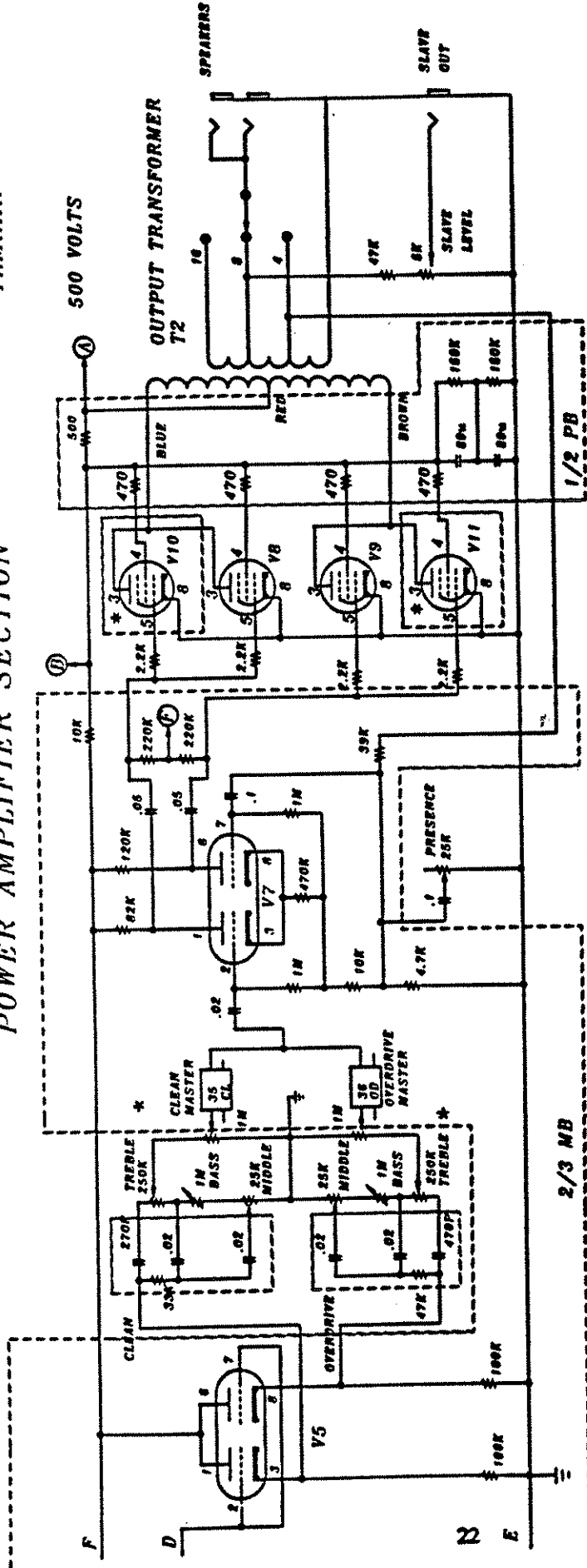

* - T100 ONLY

* Please read Production up-dates page 14

THE DC VOLTAGE LISTED IN THE TABLE IS THE NOMINAL DC VOLTAGE FOR THAT PIN BASED ON 117 VOLTS AC LINE.

ALL VOLTAGE IS MEASURED WITH RESPECT TO POWER GROUND

TUBE #	1	2	3	4	5	6	7	8	9
V1	166	1.2				222		1.8	
V2	209	1.6				266		3.3	
V3	184	1.8				329		3.3	
V4	189	1.4				189		1.4	
V5	329	199				329		199	
V6	428	2.7				179		1.2	
V7	213	34				204		34	
V8		470	462		-50			0	
V9		470	462		-50			0	

T2 - OUTPUT TRANSFORMER
T50-T50C = 0-51Y-1
T100-T100C = 0-101Y-1

V5 - 7 = 12AX7
V8, 9 = 6L6CC
V10, 11 = 6L6CC T100 ONLY