

ECO#	REV:	DESCRIPTION	REV. BY:	APP. BY:	DATE
01		PROTOTYPE RELEASE	SOBEK	Violi	28.3.01
02		R56-R59-R87-R90 da 5K9 a 5K6	Adami	Violi	23.5.2001

D

C

B

A

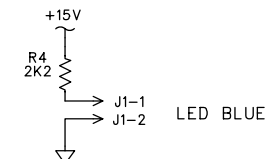
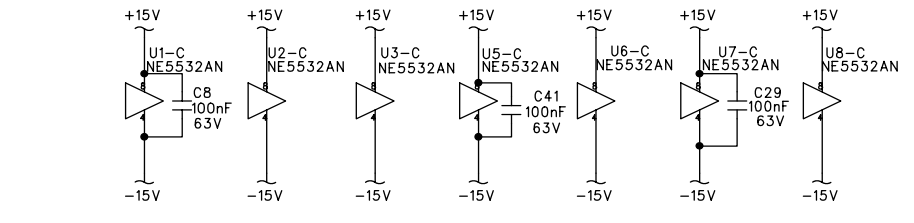
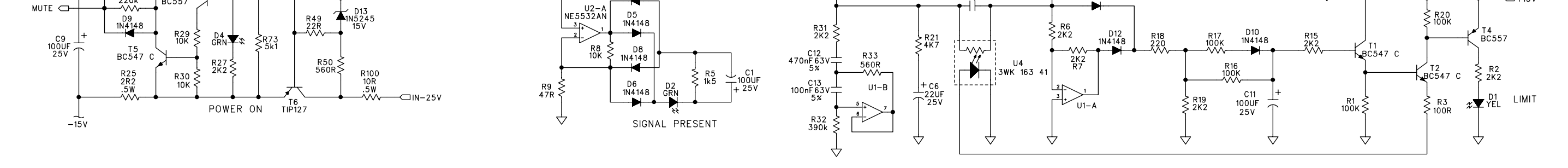
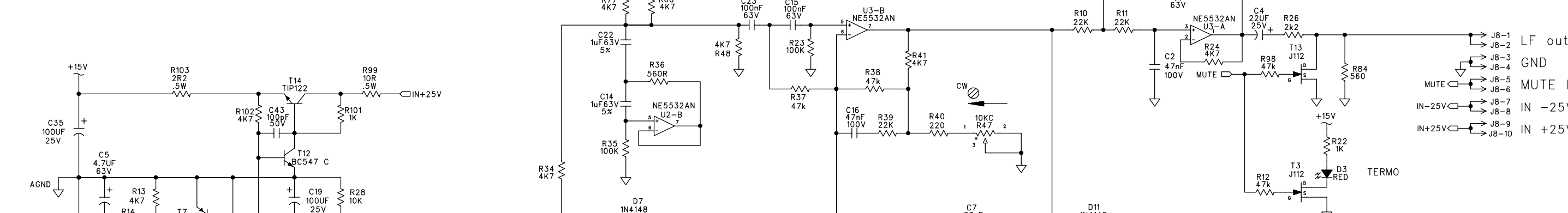
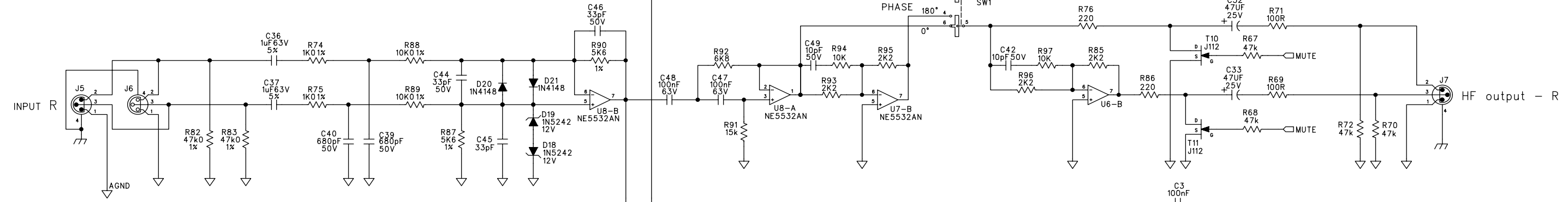
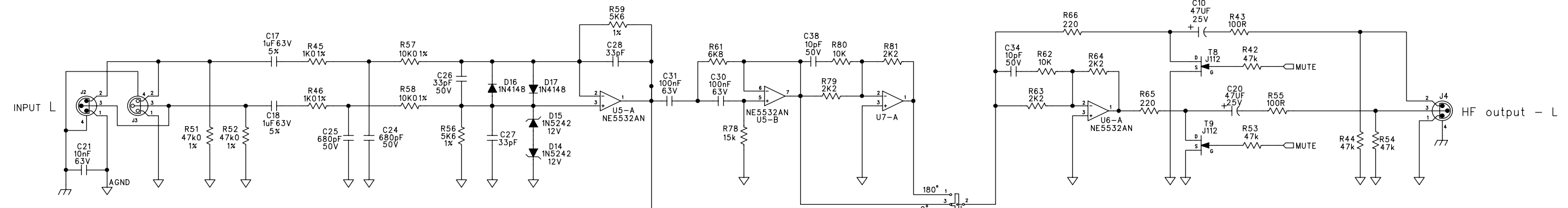

APPROVALS		DATE
DRAWN: SOBEK		28.3.2001
CHECKED: VIOLI		23.5.2001
NP ENG:		
MATERIAL:		
MFG:		
MFG ENG:		
ISSUED:		

MACKIE
Mackie Designs Italy

SCHMATIC, INPUT MODULE

SRS 1501

SIZE: D	SCALE: NONE	DWG. NO. Cod. SE036964	REV. 02
---------	-------------	------------------------	---------

DO NOT SCALE DRAWING

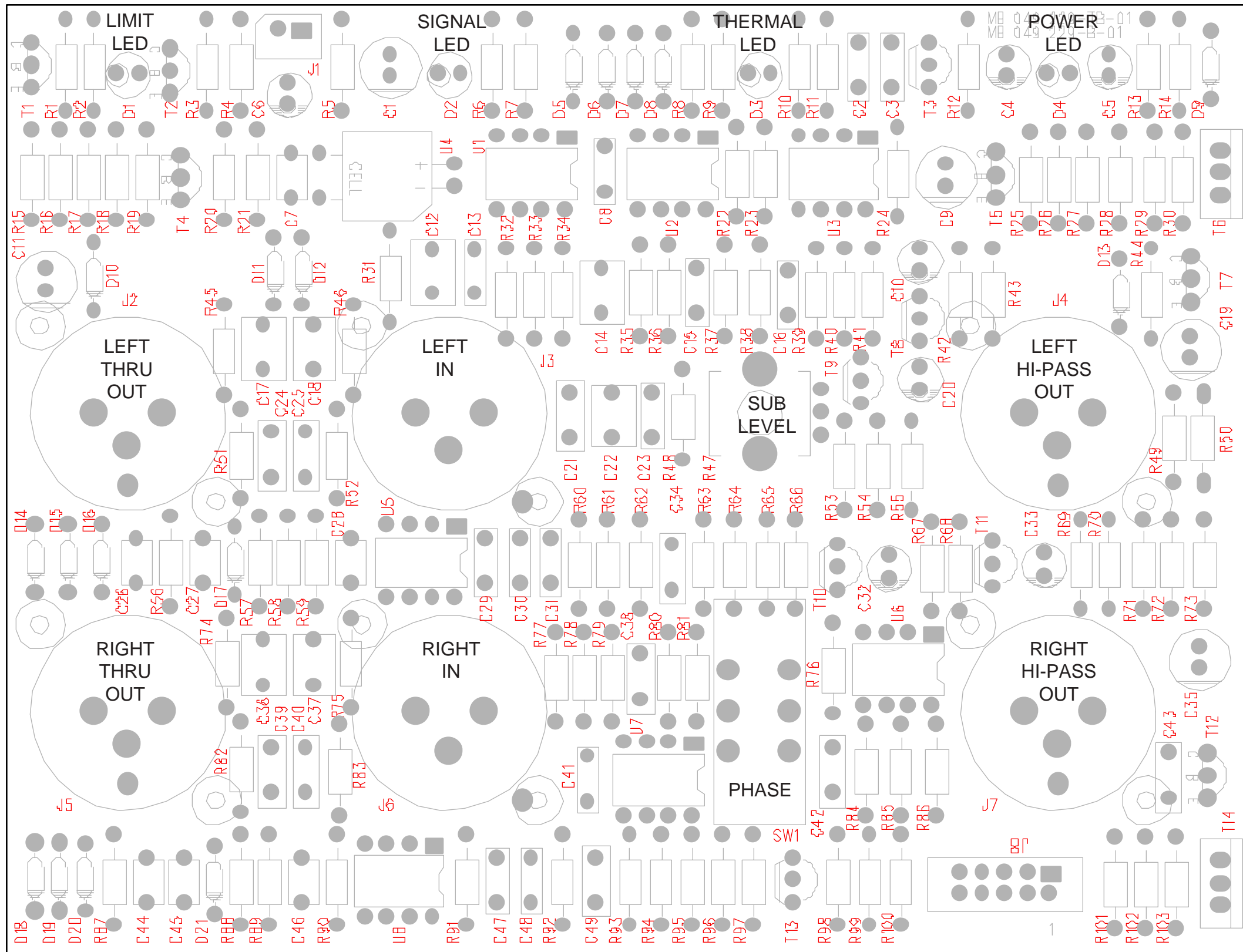

Top Surface

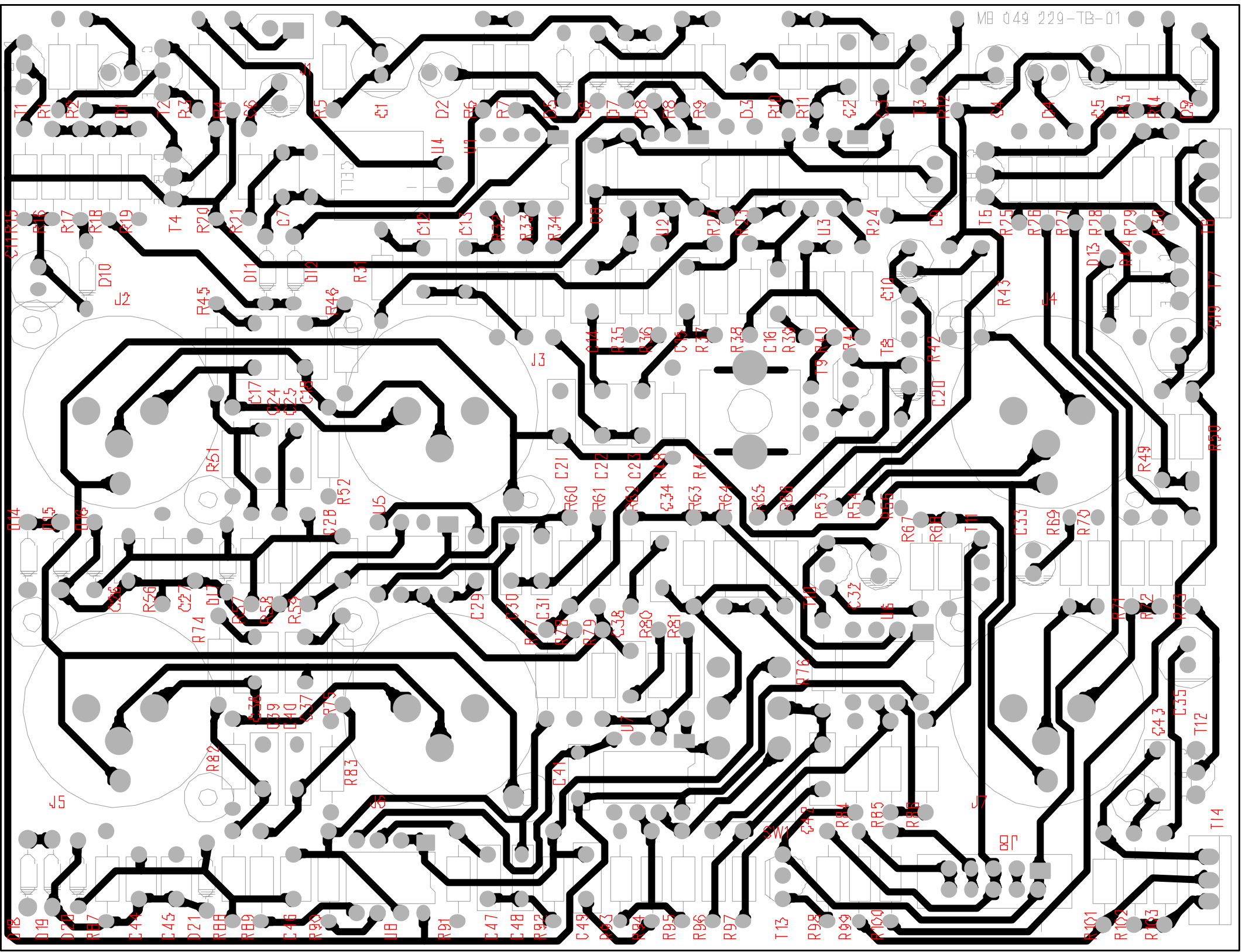

Top Surface

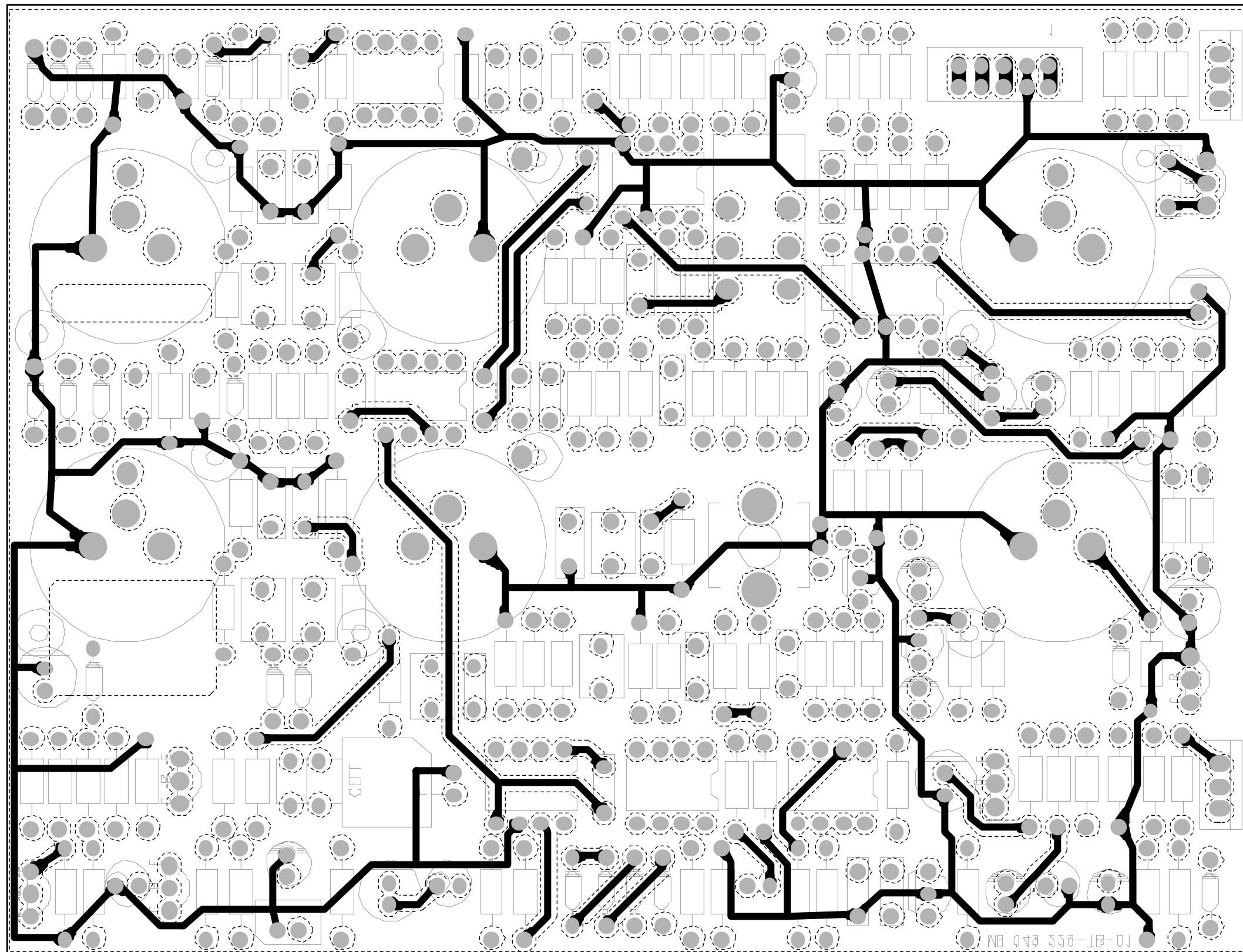

Bottom Surface
(dotted lines are the copper
pour boundary)

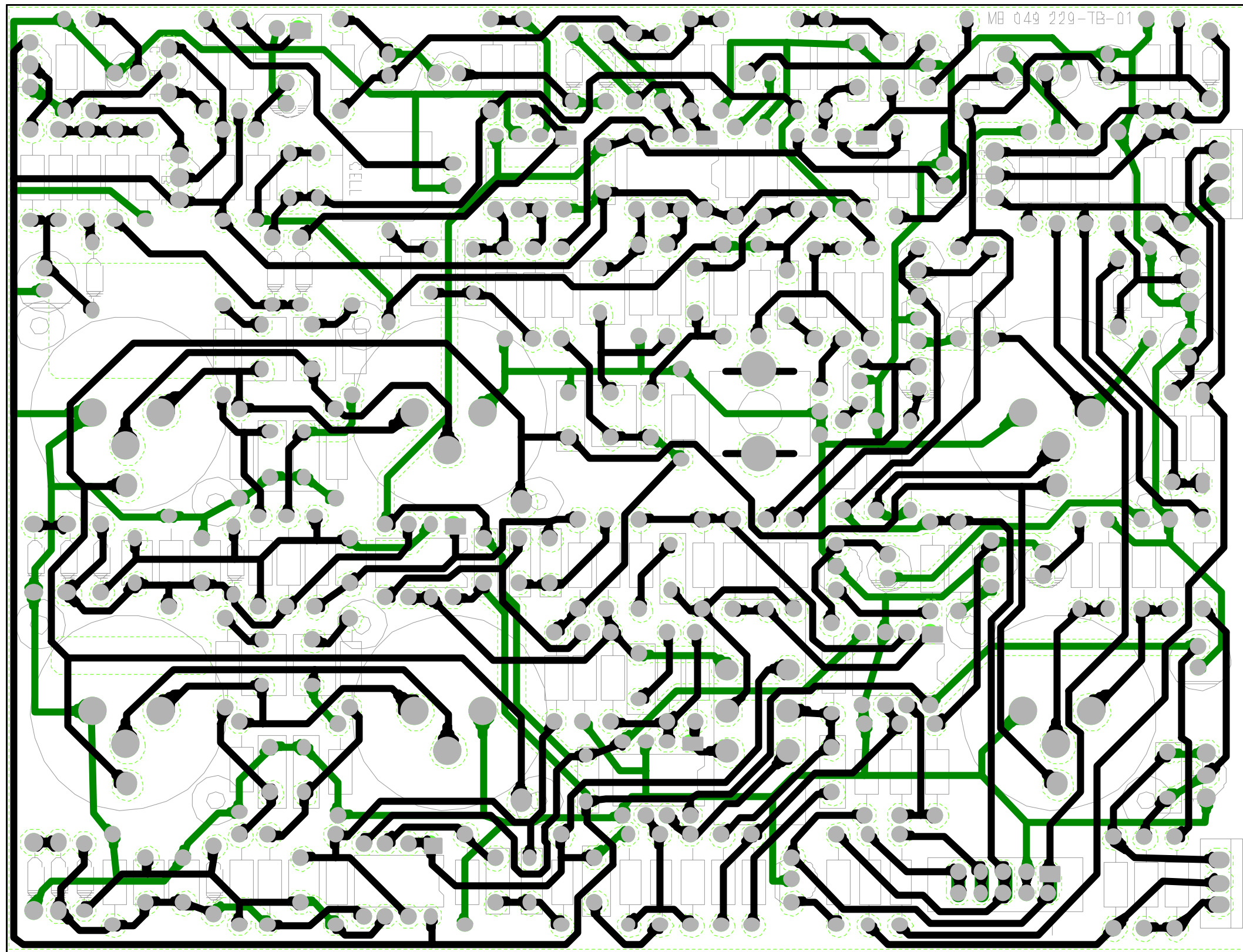

Top Surface has grey pads and black lines (dotted lines are the copper pour boundary)

Bottom Surface has green pads and lines (dotted lines are the copper pour boundary)