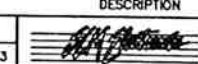

NOTES

- 1) CAUTION: SHOCK HAZARD!!
THIS UNIT CONTAINS HAZARDOUS VOLTAGE. DISCONNECT POWER AND BE SURE POWER SUPPLY IS DISCHARGED BEFORE TOUCHING INTERNAL PARTS.
- 2) UNLESS NOTED, RESISTOR VALUES IN OHMS, 1/4W-5% TOL. CAPACITOR VALUES IN MICROFARADS, 50V-10% TOL.
- 3) VOLTAGES ARE MEASURED WITH 1 MEGOHM OSCILLOSCOPE AND 10 MEGOHM DIGITAL VOLTMETER.
- 4) VOLTAGES IN RECTANGLES ARE RMS SIGNAL VOLTAGES WITH 0.4v IN. OTHER VOLTAGES ARE D.C. IN CONDITIONS STATED.
- 5) CIRCUIT GROUND ∇ DIRTY GROUND ∇ CHASSIS GROUND ∇

CAUTION:

THIS SCHEMATIC IS PROVIDED FOR USE BY QUALIFIED PERSONNEL. TO AVOID RISK OF ELECTRIC SHOCK, REFER SERVICING TO QUALIFIED SERVICE PERSONNEL. DO NOT PERFORM ANY SERVICING BEYOND THAT EXPLAINED IN THE OPERATING INSTRUCTIONS.

3				
2	05/16/94	LMA		REV CHG TO REFLECT JUMPER CHG PER E150
1	05/05/94	REM		CHANGED VALUES OF R24, R25, R32, R33 PER ED190.
REV	DATE	BY	CHK'D	DESCRIPTION
SIGNATURES:		DATE:		 TERRY BORMAN DR. ST. LOUIS, MISSOURI 63148
DRAWN:	REM	11/15/93		
CHK'D:	GM	11/15/93		PROJECT NAME:
APP'D:	GM	11/15/93		SVT-CL
ORIGINAL ISSUED:	11/15/93	DRAWING NAME:		PWR AMP SCHEMATIC
PLOT DATE:	05/16/94	DRAWING NO.:		07S419-11
PLOT TIME:	11:30:31	REV.:		2
FILE NAME:	41911H2Z	SCALE:	~	SHEET: 2 OF 2

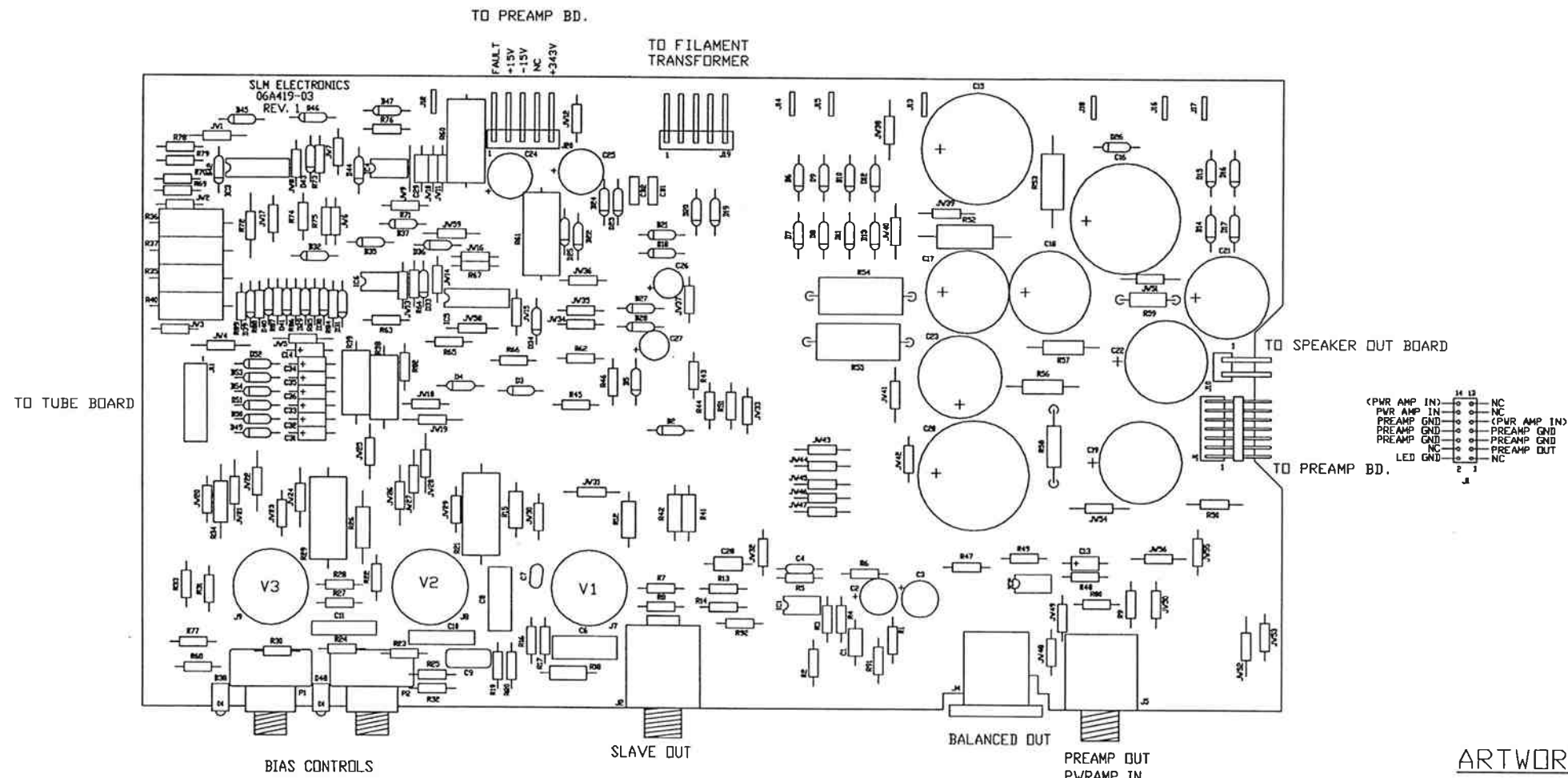

ARTWORK REV. 1

TO ADJUST BIAS:
 ALLOW UNIT TO WARM UP FOR 20 MINUTES.
 ADJUST BIAS CONTROLS SO THAT ONLY THE GREEN LEDS
 ARE LIT. FOR UNMATCHED TUBES THIS CONDITION MAY
 NOT BE ABLE TO BE MET. IF SO ADJUST CONTROLS
 SO THAT ONLY THE RED LEDS ARE LIT. SEE THE OWNER'S
 MANUAL FOR TROUBLESHOOTING TIPS USING THE BIAS
 CONTROLS AND LEDS.

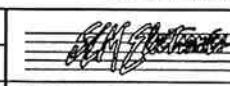
3				
2	05/16/94	LMA		76-000-01 TO -05 PER E150
1	05/05/94	REM		CHANGED VALUES OF R24, R25, R32, R33 PER E0190.
REV	DATE	BY	CHK'D	DESCRIPTION
SIGNATURES:		DATE:		 1880 BORMAN DR. ST. LOUIS, MISSOURI 63146
DRAWN:	REM	11/15/93		
CHK'D:	RC	11/22/93		PROJECT NAME:
APP'D:	GM	11/22/93		SVT-CL
ORIGINAL ISSUED:	11/15/93			DRAWING NAME:
PLOT DATE:	05/16/94			PWR AMP PICTORIAL
PLOT TIME:	11:25:48			DRAWING NO. 07S419-11
FILE NAME:	41911P22			REV. 2
SCALE: 1:1		SHEET: 1 OF 2		

DESIGNATOR	PART #	DESCRIPTION
CB1	73-101-01	1/4A THRMSTR
CB2	73-101-01	1/4A THRMSTR
C1	10A104-01	0.1 50V
C2	12-476-62	47 63V
C3	12-476-62	47 63V
C4	10A101-21	100pf 200V
C5	NOT USED	
C6	10-104-10	0.1 400V
C7	10-500-02	50pf 500V
C8	10-104-10	0.1 400V
C9	10-104-21	0.1 200V
C10	10-473-10	0.047 400V
C11	10-473-10	0.047 400V
C12	NOT USED	
C13	12A106-11	10uF 16V
C14	12A105-51	1uF 50V
C15	12-107-30	100 450V
C16	12-107-30	100 450V
C17	12-476-42	47 450V
C18	12-476-42	47 450V
C19	12-476-42	47 450V
C20	12-107-30	100 450V
C21	12-476-42	47 450V
C22	12-476-42	47 450V
C23	12-107-62	100 250V
C24	12-227-32	220 35V
C25	12-227-32	220 35V
C26	12-227-12	220 16V
C27	12-227-12	220 16V
C28	10A473-11	0.047 100V
C29	10A473-11	0.047 100V
C30	NOT USED	
C31	12A106-11	10uF 16V
C32	12A106-11	10uF 16V
C33	12A106-11	10uF 16V
C34	12A106-11	10uF 16V
C35	12A106-11	10uF 16V
C36	12A106-11	10uF 16V
D1	NOT USED	
D2	21A914-01	1N914
D3	21A370-01	1N3070
D4	21A370-01	1N3070
D5	21A914-01	1N914
D6	21A407-01	1N4007
D7	21A407-01	1N4007
D8	21A407-01	1N4007
D9	21A407-01	1N4007
D10	21A407-01	1N4007
D11	21A407-01	1N4007
D12	21A407-01	1N4007
D13	21A407-01	1N4007
D14	21A407-01	1N4007
D15	21A407-01	1N4007
D16	21A407-01	1N4007
D17	21A407-01	1N4007
D18	21A407-01	1N4007
D19	21A407-01	1N4007
D20	21A407-01	1N4007
D21	21A407-01	1N4007
D22	21A407-01	1N4007

D23	21A407-01	1N4007
D24	21A407-01	1N4007
D25	21A407-01	1N4007
D26	21A407-01	1N4007
D27	21A444-01	1N4744 15V/1W
D28	21A444-01	1N4744 15V/1W
D29	21A370-01	1N3070
D30	21A370-01	1N3070
D31	21A370-01	1N3070
D32	21A914-01	1N914
D33	21A914-01	1N914
D34	21A914-01	1N914
D35	21A914-01	1N914
D36	21A914-01	1N914
D37	21A914-01	1N914
D38	21-512-01	RED/GRN LED
D39	21A370-01	1N3070
D40	21A370-01	1N3070
D41	21A370-01	1N3070
D42	21A914-01	1N914
D43	21A914-01	1N914
D44	21A914-01	1N914
D45	21A914-01	1N914
D46	21A914-01	1N914
D47	21A914-01	1N914
D48	21-512-01	RED/GRN LED
D49	21A370-01	1N3070
D50	21A370-01	1N3070
D51	21A370-01	1N3070
D52	21A370-01	1N3070
D53	21A370-01	1N3070
D54	21A370-01	1N3070
IC1	37-532-01	NE5532
IC2	37-072-01	TLD72
IC3	37-074-01	TLD74
IC4	37-072-01	TLD72
IC5	37-074-01	TLD74
IC6	37-072-01	TLD72
J1	17-101-14	14PIN R/A-HEADER
J2	39-116-51	T/S JACK
J3	NOT USED	
J4	39-308-01	MALE XLR
J5	39-910-01	JACK STACKED
J6	NOT USED	
J7	17-450-09	9PIN TUBE SOCKET
J8	17-450-09	9PIN TUBE SOCKET
J9	17-450-09	9PIN TUBE SOCKET
J10	17-311-02	2PIN R/A-HEADER
J11	17-101-16	16PIN DR_HEADER
J12	17-836-01	TAB
J13	17-836-01	TAB
J14	17-836-01	TAB
J15	17-836-01	TAB
J16	17-836-01	TAB
J17	17-836-01	TAB
J18	17-836-01	TAB
J19	17-311-05	5PIN R/A-HEADER
J20	17-311-05	5PIN R/A-HEADER
JW1-8	76-000-05	JUMPER
JW9	76-000-05	JUMPER
JW10-56	76-000-05	JUMPER
JW57	76-000-05	JUMPER
JW58-59	76-000-05	JUMPER

P1	70-503-20	50KL
P2	70-503-20	50KL
P3	NOT USED	
R1	76-223-01	22K
R2	76-472-01	4.7K
R3	76-103-01	10K
R4	76-331-01	330
R5	76-103-01	10K
R6	76-331-01	330
R7	76-102-01	1K
R8	76-474-01	470K
R9	76-222-01	2.2K
R10	NOT USED	
R11	NOT USED	
R12	77-104-02	100K 1/2W 1%
R13	76-102-01	1K
R14	76-221-01	220
R15	77-683-01	68K 1/2W
R16	76-105-01	1M
R17	76-821-01	820
R18	77-683-01	68K 1/2W
R19	76-474-01	470K
R20	76-182-01	1.8K
R21	78-473-05	47K 5W
R22	76-154-01	150K
R23	76-154-01	150K
R24	76-124-01	120K
R25	76-683-01	68K
R26	78-473-01	47K 1W
R27	76-474-01	470K
R28	76-182-01	1.8K
R29	78-473-05	47K 5W
R30	76-154-01	150K
R31	76-154-01	150K
R32	76-683-01	68K
R33	76-124-01	120K
R34	78-473-01	47K 1W
R35	78-100-92	10 2W-H.SRG
R36	78-100-92	10 2W-H.SRG
R37	78-100-92	10 2W-H.SRG
R38	78-100-92	10 2W-H.SRG
R39	78-100-92	10 2W-H.SRG
R40	78-100-92	10 2W-H.SRG
R41	78-221-91	220 1W-H.SRG
R42	78-221-91	220 1W-H.SRG
R43	76-683-01	68K
R44	76-472-01	4.7K
R45	76-473-01	47K
R46	76-223-01	22K
R47	76-104-01	100K
R48	76-104-01	100K
R49	76-224-01	220K
R50	76-103-01	10K
R51	76-472-01	4.7K
R52	78-154-02	150K 2W
R53	78-154-02	150K 2W
*R54	78-153-05	15K 5W
*R55	78-473-05	47K 5W
R56	78-224-01	220K 1W
R57	78-224-01	220K 1W
*R58	78-473-01	47K 1W
*R59	77-222-01	2.2K 1/2W

R60	78-500-05	50 5W
R61	78-500-05	50 5W
R62	76-151-01	150
R63	76-102-01	1K
R64	76-151-01	150
R65	76-102-01	1K
R66	76-102-01	1K
R67	76-153-01	15K
R68	76-682-01	6.8K
R69	76-222-01	2.2K
R70	76-222-01	2.2K
R71	76-151-01	150
R72	76-102-01	1K
R73	76-151-01	150
R74	76-102-01	1K
R75	76-102-01	1K
R76	76-153-01	15K
R77	76-682-01	6.8K
R78	76-222-01	2.2K
R79	76-222-01	2.2K
R80	76-105-01	1M
R81	NOT USED	
R82	76-333-01	33K
R83	NOT USED	
R84	76-222-01	2.2K
R85	76-222-01	2.2K
R86	76-222-01	2.2K
R87	76-222-01	2.2K
R88	76-222-01	2.2K
R89	76-222-01	2.2K
R91	76-473-01	47K
R92	76-221-01	220
*R95	NOT USED	

S1	NOT USED	
(8)	85-061-01	SPACERS
PCB1	06A419-03	PC BOARD
V1	97-927-01	12AX7
V2	95-126-01	12AU7
V3	95-126-01	12AU7

* USES SPACERS
*1 BREAK IN SEQUENCE

3				
2	05/16/94	LMA		76-000-01 TO -05 PER E150
(1)	05/05/94	REM		CHANGED VALUES OF R24, R25, R32, R33 PER E0190.
REV	DATE	BY	CHK'D	DESCRIPTION
SIGNATURES:		DATE:		 1180 BORMAN DR. ST. LOUIS, MISSOURI 63146
DRAWN:	REM	11/15/93		
CHK'D:	RC	11/22/93	PROJECT NAME:	
APP'D:	GM	11/22/93	SVT-CL	
ORIGINAL ISSUED:	11/15/93	DRAWING NAME:		PWR AMP PICTORIAL
PLOT DATE:	05/16/94			
PLOT TIME:	11:25:48	DRAWING NO.	07S419-11	REV. 2
FILE NAME:	41911P2Z	SCALE:	1:1	SHEET: 2 OF 2

SUT-CL Pwr AMP

162 ✓

B

C

D

E

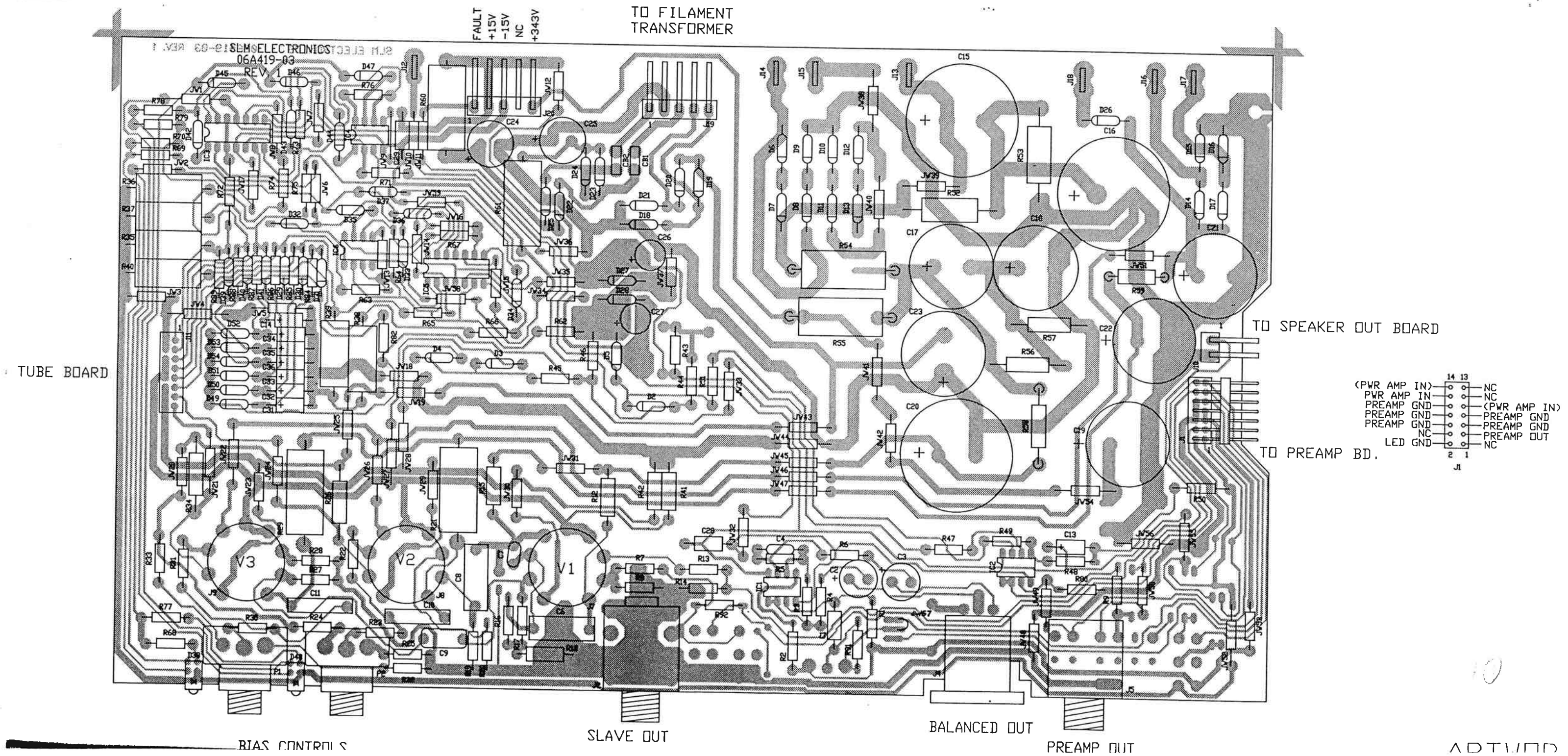

(PWR AMP IN)	14	13	NC
PWR AMP IN	12	11	NC
PREAMP GND	10	9	(PWR AMP IN)
PREAMP GND	8	7	PREAMP GND
PREAMP GND	6	5	PREAMP GND
NC	4	3	PREAMP OUT
LED GND	2	1	NC

J1

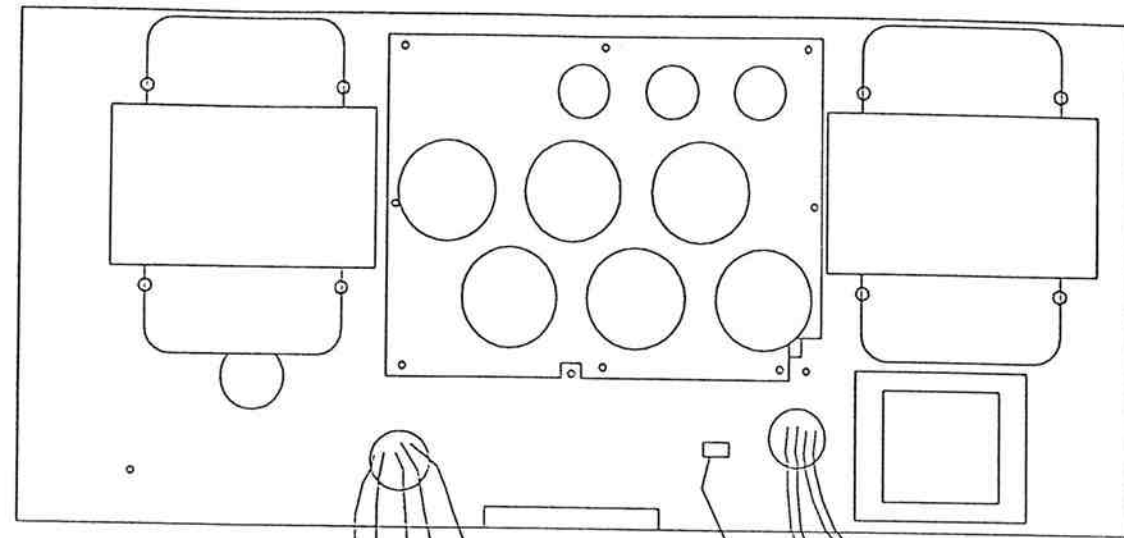

()=PARTS ON 16-412-01

KEEP BOTH ENDS INSIDE CHASSIS

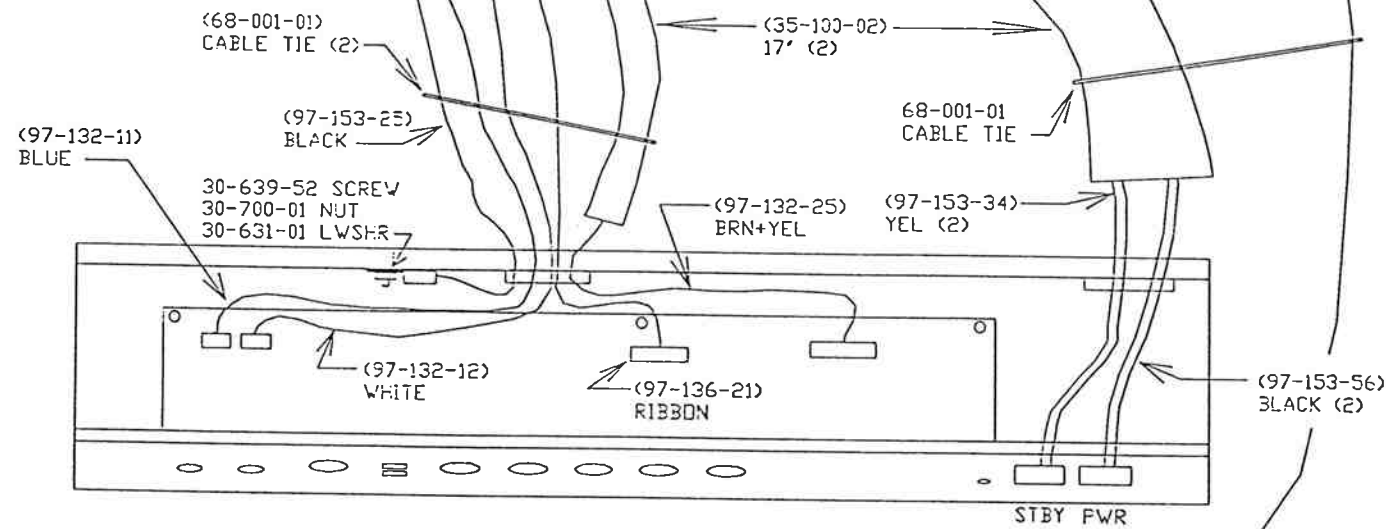

3/4"

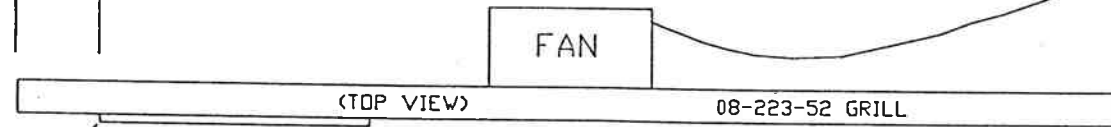

68-009-51 LOGO
 INSTALL WITH (2) 30-612-10
 3/4" FROM LEFT SIDE; 1" FROM TOP

51-115-01 HANDLE (2)
 30-838-03 SCREW (28)
 ON SIDES

51-891-01 CORNER (6)
 30-838-03 SCREW (12)

30-883-01 SCREW (4)
 30-861-71 WASHER (4)

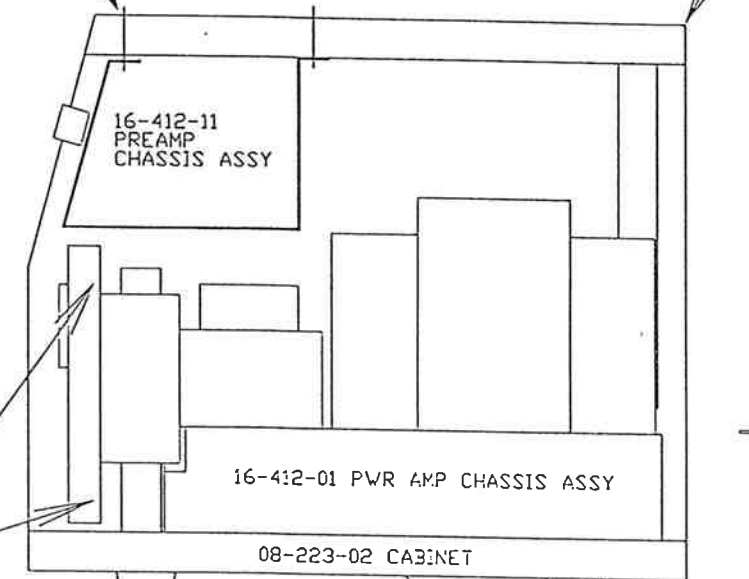

51-405-01 GRILL
 INSTALL WITH
 30-612-01 SCREW (6)

30-832-01 T-NUT (4) INSIDE
 30-871-52 SCREW (4)
 61-202-01 FEET (4)

30-891-01 SCREW (5)
 30-850-06 WASHER (5)
 TO CHASSIS

GRILL AND FAN ASSY
 INSTALL WITH
 68-035-01 FASTENER (8)
 30-612-01 SCREW (8)

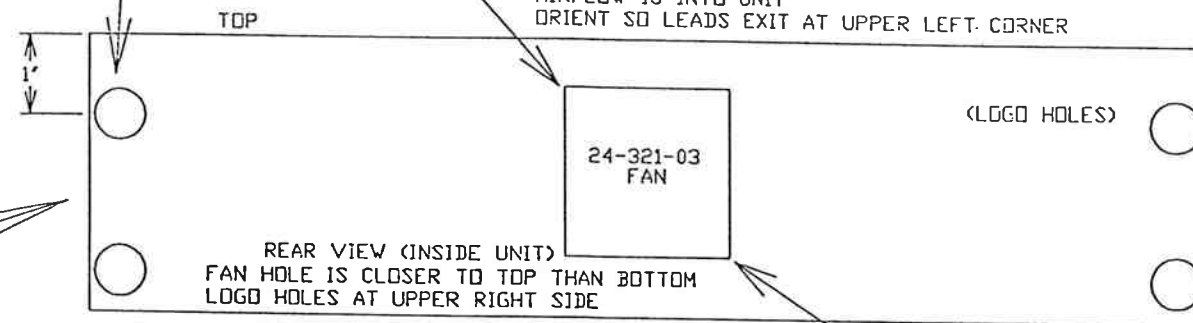

FAN MOUNTED CLOSER TO TOP
 AIRFLOW IS INTO UNIT
 ORIENT SO LEADS EXIT AT UPPER LEFT CORNER

2-16-94 REV 0 GM
 7-18-94 REV 1 GM CHANGED LOGO, MOUNTING

SVTCLFIN.DWG

SVT-CL FINAL ASSEMBLY