

CONFIDENTIAL

INPUT THIRTEEN-FOURTEEN

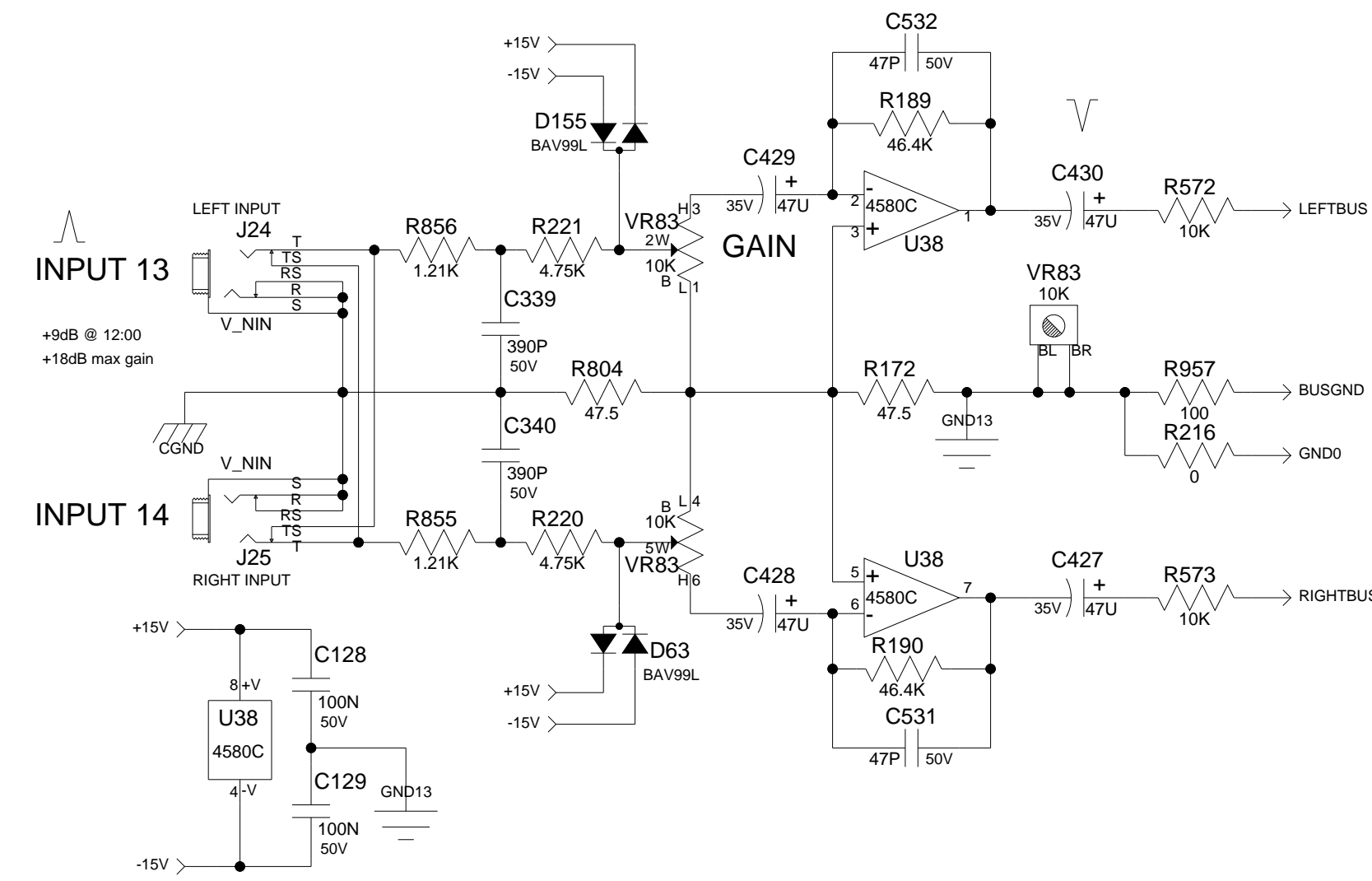

C.R LEVELS

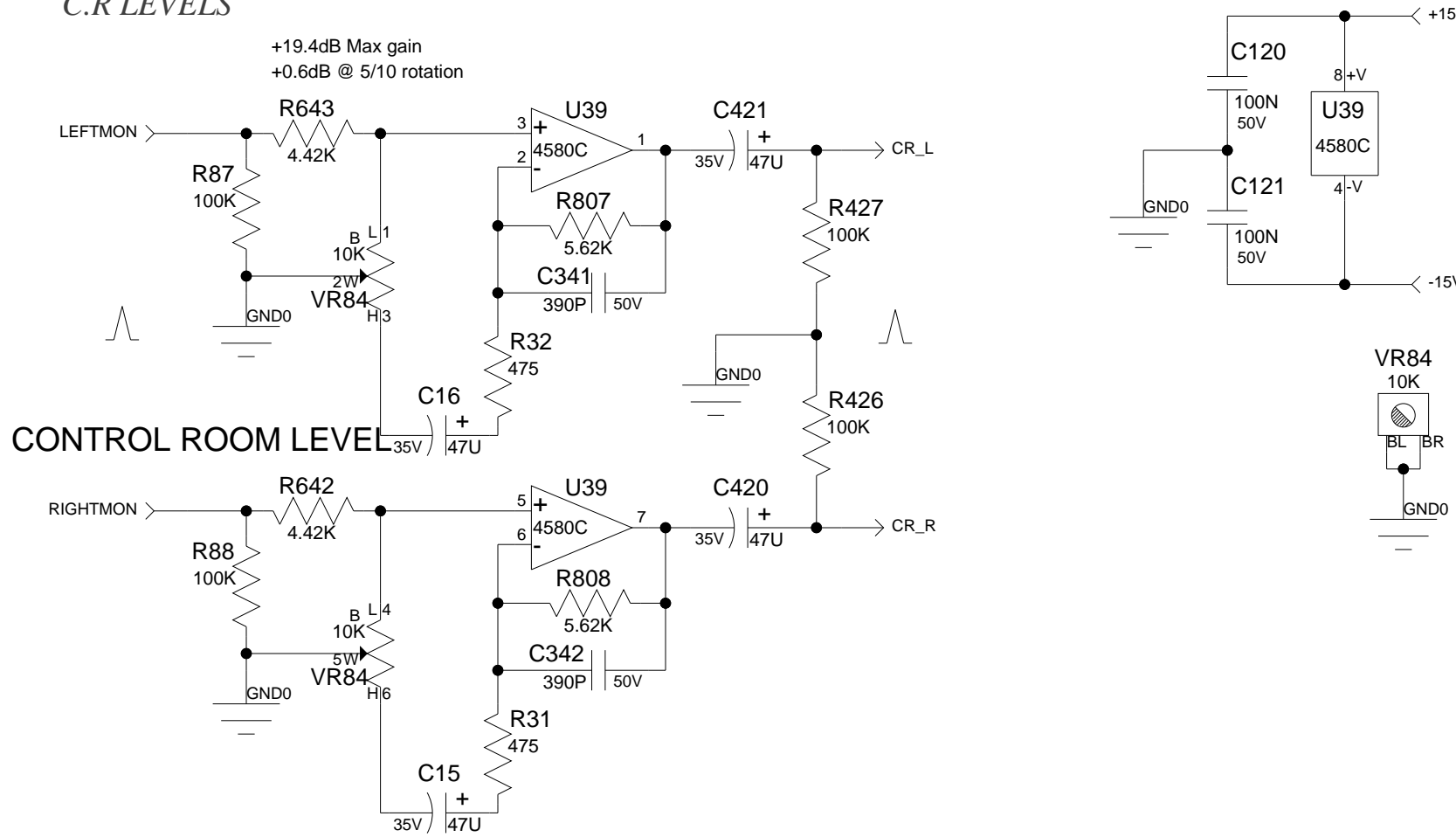

CONTROL ROOM OUTS

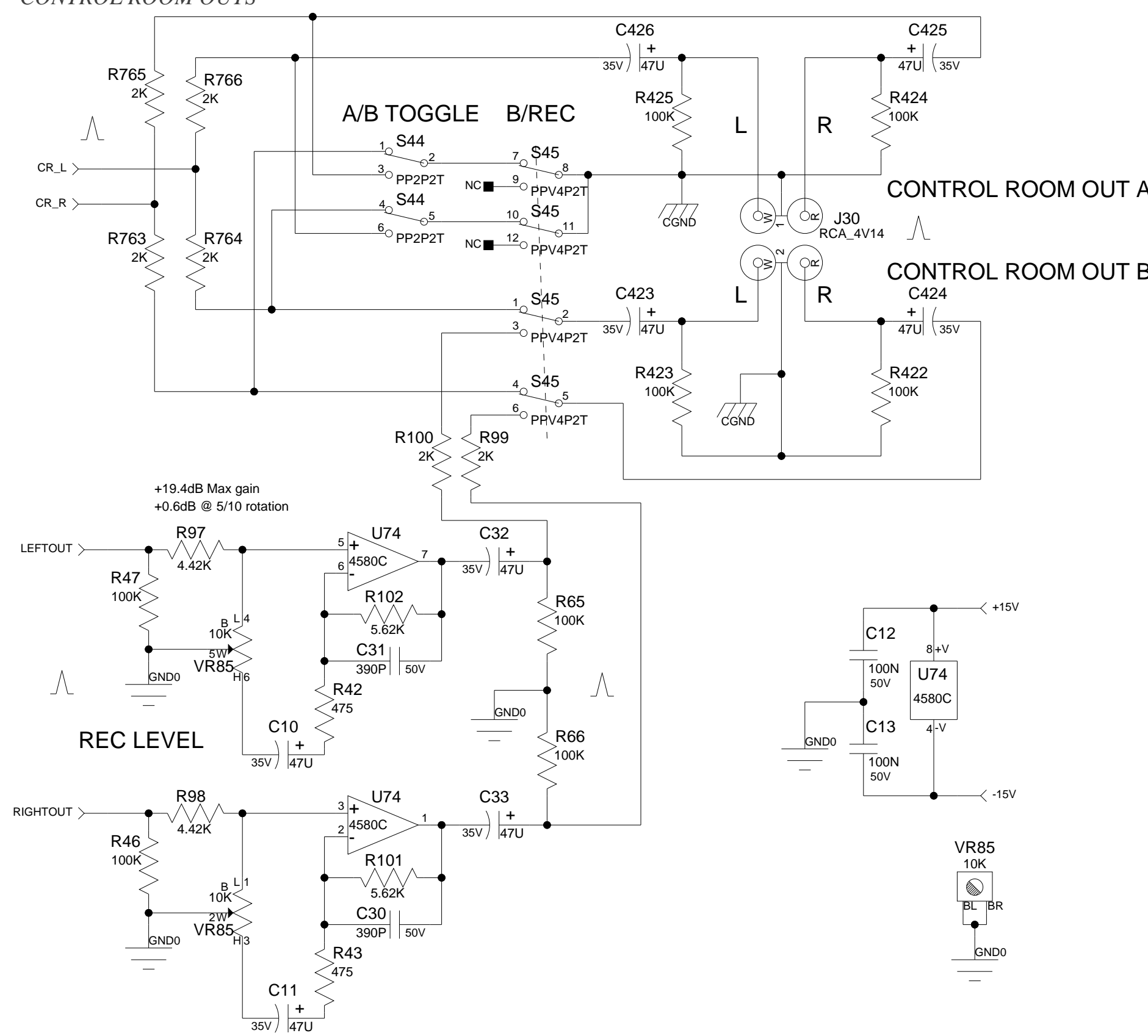

SOLO SUM / PFL

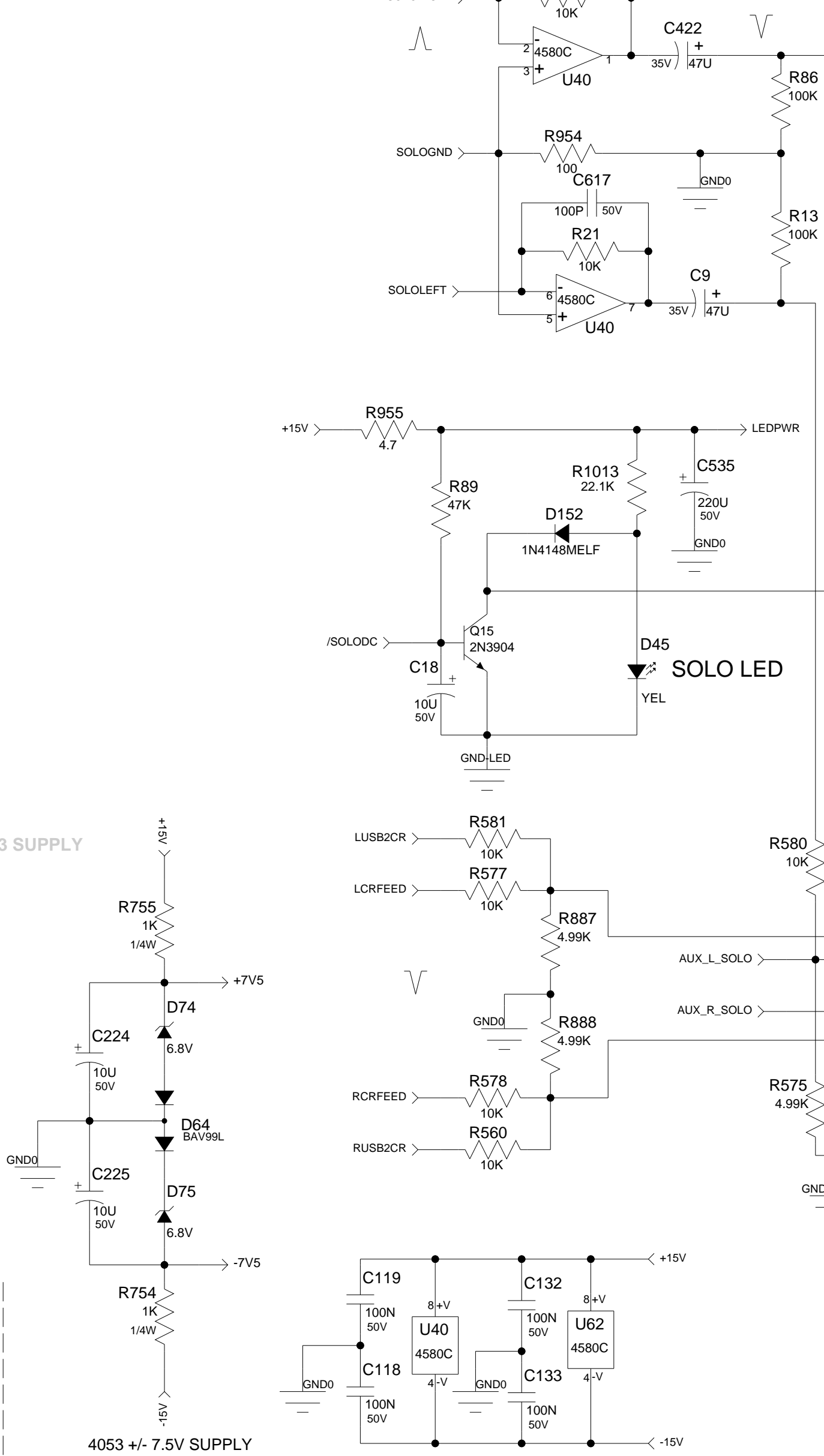

POWER

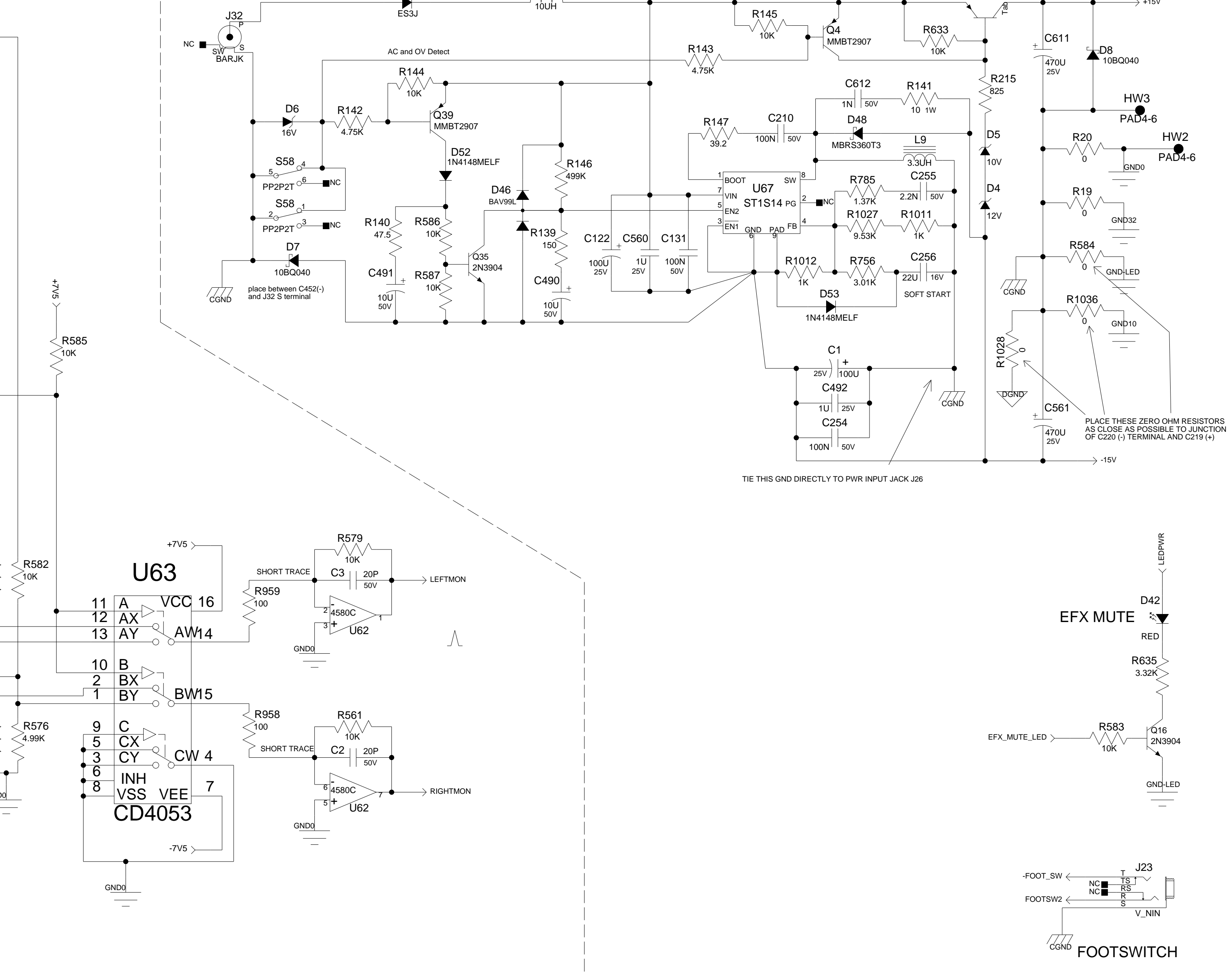

MAIN SUM

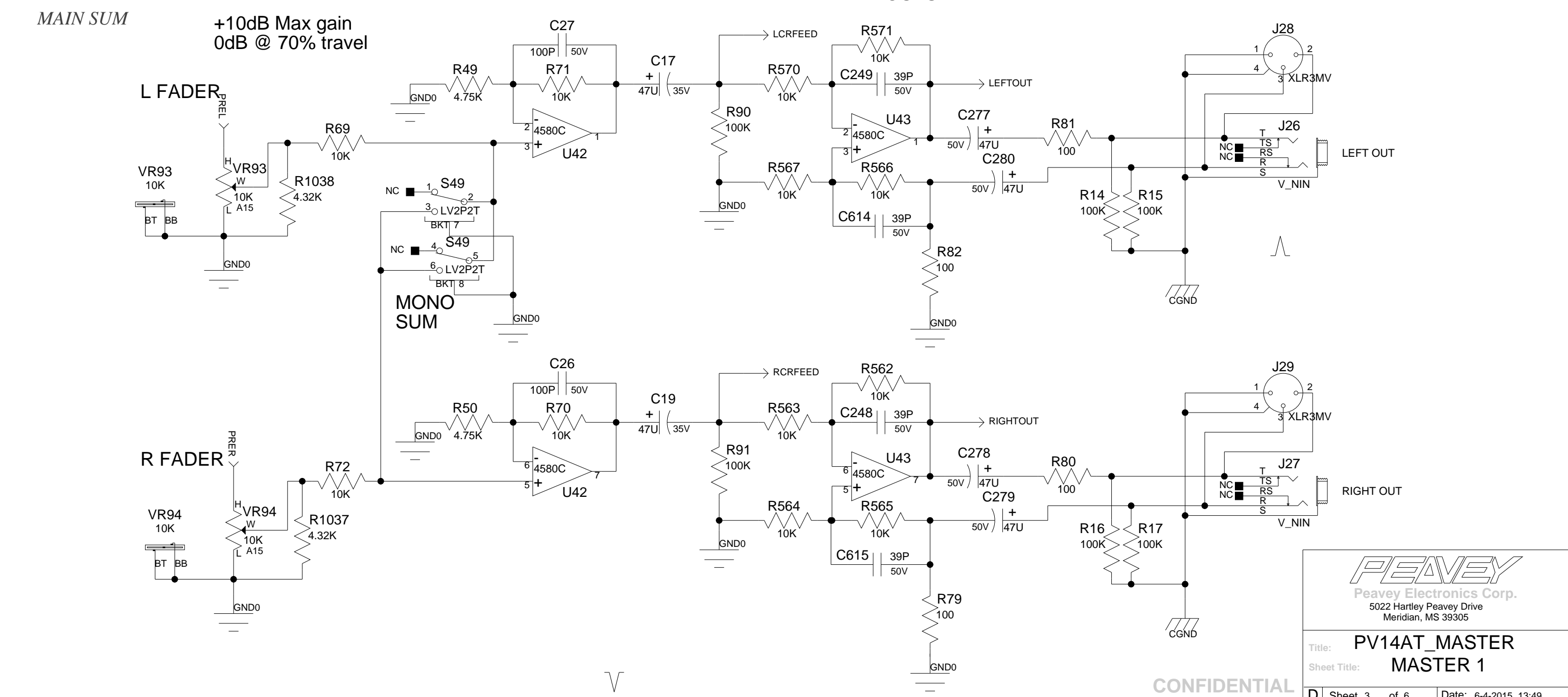

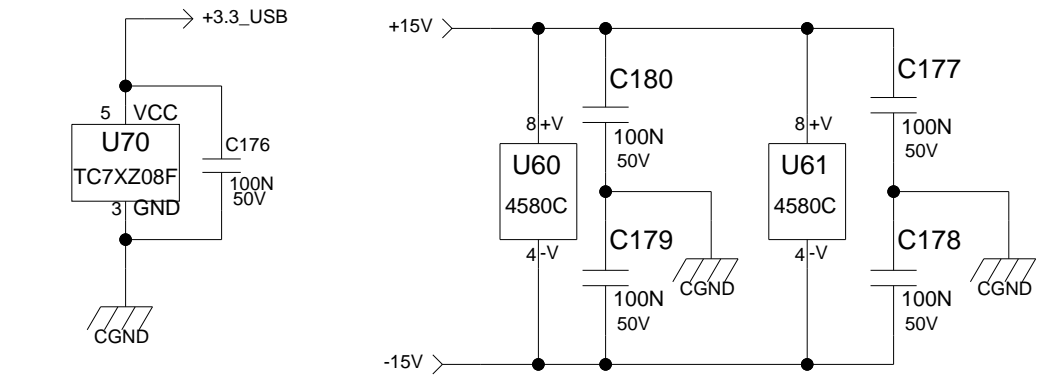
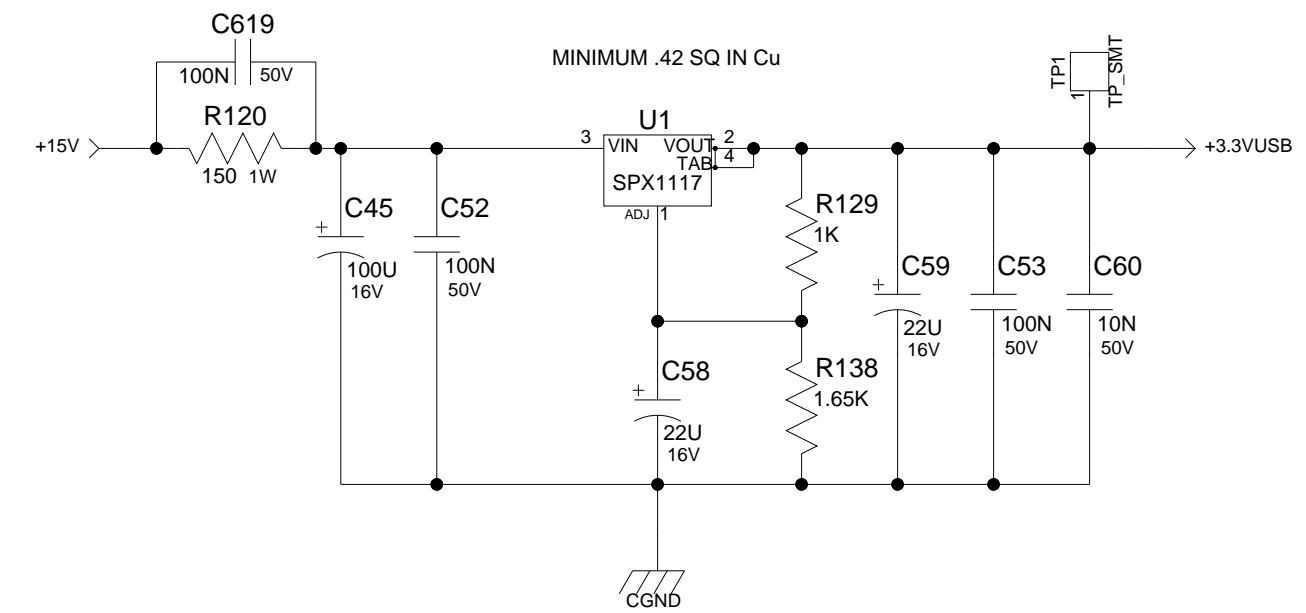
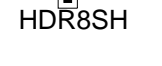
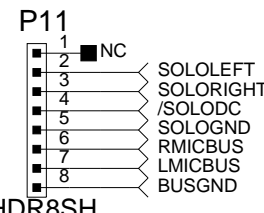
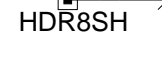
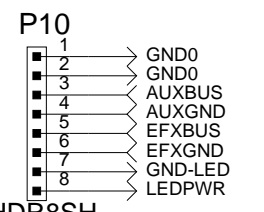
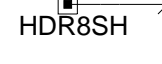
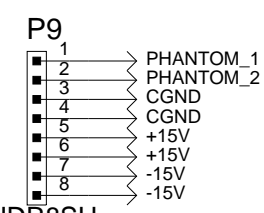
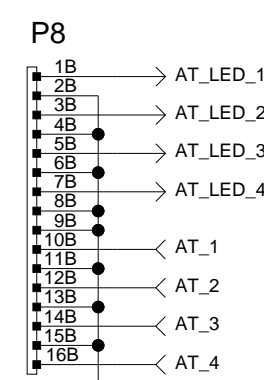
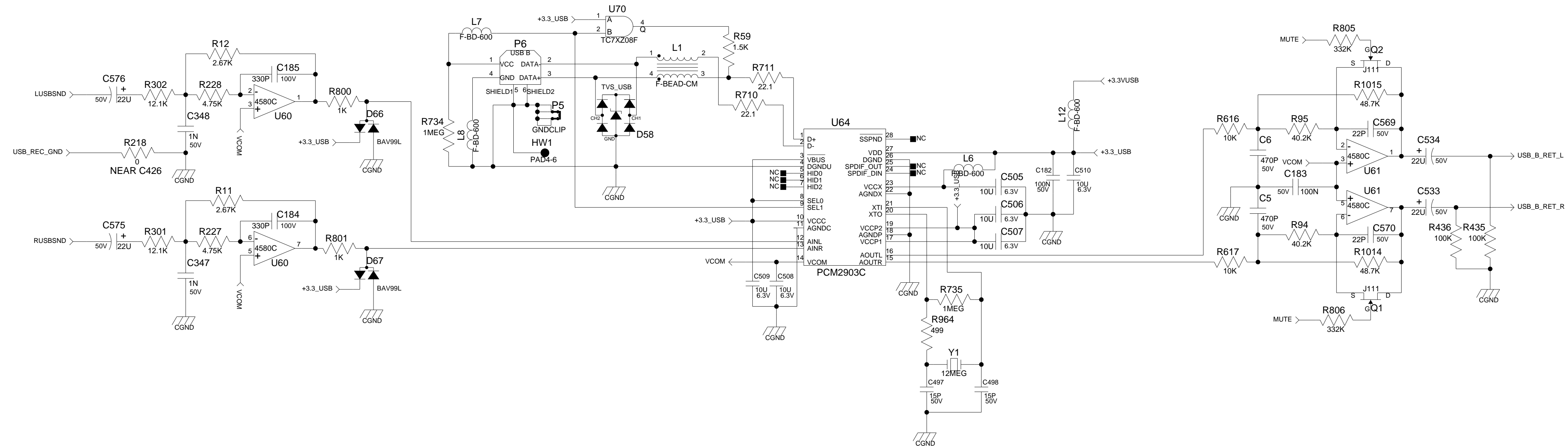

Peavey Electronics Corp.
5022 Hartley Peavey Drive
Meriden, MS 39305

Title: PV14AT_MASTER
Sheet Title: USB
Date: 6-4-2015_13:49

CONFIDENTIAL

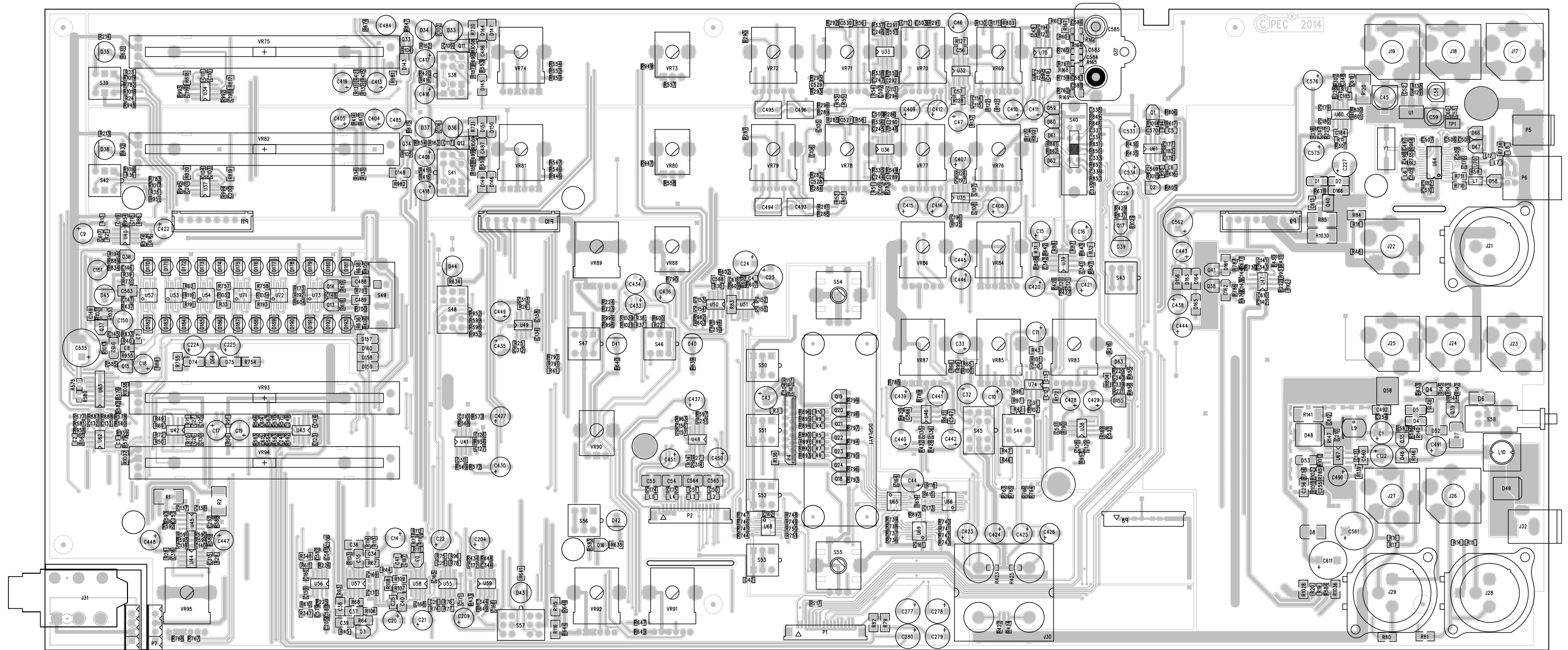

BILL OF MATERIAL REPORT

REPORT DATE/TIME: 6/5/2015 3:55:56 PM

BOARD NAME: PV14 AT Master ASSEMBLY LEVEL NUMBER: 32206993

PROJECT NUMBER: P1400033 DESIGNER: FJE - 32102252

Qty.	Part #	Description	Reference Designators
2	30200010	0.0 1/4W 5% MF 1206	R1028 R1036
2	30200047	1K 1/4W 1% MF 1206	R754 R755
6	30200060	100 1/4W 1% MF 1206	R79 R80 R81 R82 R83 R84
1	30200175	1.1K 1/10W 1% MF 0805	R193
1	30200189	1.37K 1/10W 1% MF 0805	R785
2	30200195	1.00M 1/10W 1% MF 0805	R734 R735
5	30200202	3.32K 1/10W 1% MF 0805	R634 R635 R636 R638 R641
2	30200214	2.21K 1/4W 1% MF 1206	R720 R721
1	30200239	10 1W 1% MF 2512	R141
1	30200241	4.70 1/10W 1% MF 0805	R955
1	30200242	150 1/10W 1% MF 0805	R139
4	30200243	316 1/10W 1% MF 0805	R166 R167 R168 R169
3	30200264	499 1/10W 1% MF 0603	R130 R137 R964
1	30200267	2.21K 1/10W 1% MF 0805	R758
8	30200281	0.0 JUMPER 0.1 0603	R19 R20 R213 R214 R216 R217 R218 R584
8	30200283	1.21K 1/10W 1% MF 0603	R164 R165 R847 R848 R849 R854 R855 R856
9	30200284	1.5K 1/10W 1% MF 0603	R51 R52 R53 R54 R55 R56 R57 R58 R59

17	30200287	100	1/10W	1% MF	0603	R41 R170 R171 R946 R947 R948 R949 R950 R951 R952 R953 R954 R956 R957 R958 R959 R963
16	30200288	100K	1/10W	5% MF	0603	R13 R14 R15 R16 R17 R18 R46 R47 R48 R86 R87 R88 R90 R91 R92 R93
81	30200289	10K	1/10W	1% MF	0603	R21 R22 R69 R70 R71 R72 R73 R74 R75 R77 R78 R123 R124 R144 R145 R194 R546 R547 R548 R549 R550 R551 R552 R553 R554 R557 R558 R559 R560 R561 R562 R563 R564 R565 R566 R567 R568 R569 R570 R571 R572 R573 R574 R577 R578 R579 R580 R581 R582 R583 R585 R586 R587 R588 R589 R590 R591 R592 R593 R594 R595 R597 R598 R599 R600 R602 R603 R605 R606 R607 R608 R609 R610 R611 R614 R615 R616 R617 R633 R760 R761
1	30200290	120	1/10W	5% MF	0603	R731
6	30200291	13.7K	1/10W	1% MF	0603	R992 R993 R994 R995 R998 R999
23	30200294	1K	1/10W	1% MF	0603	R129 R678 R782 R783 R786 R787 R788 R789 R790 R791 R792 R793 R794 R795 R796 R797 R798 R799 R800 R801 R1011 R1012 R1032
5	30200295	20K	1/10W	1% MF	0603	R110 R111 R112 R113 R114
9	30200296	22.1K	1/10W	1% MF	0603	R162 R163 R596 R631 R632 R639 R640 R1013 R1029
5	30200301	3.32K	1/10W	1% MF	0603	R637 R674 R675 R676 R677

1	30200303	3.9K	1/10W	5% MF	0603	R34
8	30200306	33	1/10W	5% MF	0603	R890 R891 R892 R893 R894 R895 R896 R897
2	30200311	40.2K	1/10W	1% MF	0603	R94 R95
21	30200313	47K	1/10W	5% MF	0603	R39 R40 R89 R736 R737 R738 R739 R740 R741 R742 R743 R744 R745 R746 R747 R748 R749 R750 R751 R833 R834
2	30200314	48.7K	1/10W	1% MF	0603	R1014 R1015
1	30200318	6.49K	1/10W	1% MF	0603	R30
18	30200319	6.81K	1/10W	1% MF	0603	R281 R282 R283 R284 R285 R286 R287 R288 R289 R290 R291 R292 R293 R294 R295 R296 R645 R647
4	30200323	8.2K	1/10W	1% MF	0603	R335 R336 R337 R338
2	30200324	82K	1/10W	5% MF	0603	R104 R105
1	30200325	9.53K	1/10W	1% MF	0603	R1027
2	30200342	221K	1/10W	1% MF	0805	R1008 R1009
2	30200343	825	1/10W	1% MF	0805	R215 R757
5	30200356	475	1/10W	1% MF	0805	R31 R32 R33 R42 R43
3	30200361	5.1M	1/4W	1% MF	1206	R64 R115 R116
4	30200368	7.5K	1/10W	1% MF	0603	R850 R851 R852 R853
6	30200374	4.32K	1/10W	1% MF	0805	R817 R818 R819 R820 R1037 R1038
2	30200385	6.49K	1/10W	1% MF	0805	R127 R128
3	30200388	150	1W	1% MF	2512	R1 R2 R120
1	30200399	25.5	1/10W	1% MF	0603	R437
3	30200404	200K	1/10W	1% MF	0603	R618 R619 R730

2	30200437	1.82K	1/10W	1% MF	0805	R347 R348
2	30200443	2.2M	1/10W	5%	0805	R981 R982
1	30200455	2.4K	1/10W	1% MF	0603	R45
2	30200465	392	1/10W	1% MF	0603	R889 R1031
5	30200469	2.49K	1/10W	1% MF	0603	R60 R61 R759 R762 R1033
10	30200470	2.67K	1/10W	1% MF	0603	R3 R4 R5 R6 R7 R8 R9 R10 R11 R12
14	30200471	4.75K	1/10W	1% MF	0603	R49 R50 R142 R143 R192 R220 R221 R222 R223 R224 R225 R226 R227 R228
25	30200475	100K	1/10W	1% MF	0603	R65 R66 R414 R415 R416 R417 R418 R419 R420 R421 R422 R423 R424 R425 R426 R427 R428 R429 R430 R431 R432 R433 R434 R435 R436
4	30200476	1M	1/10W	1% MF	0603	R698 R699 R700 R701
1	30200477	24.9	1/10W	1% MF	0805	R803
8	30200483	8.06K	1/10W	1% MF	0603	R23 R24 R35 R36 R37 R38 R620 R621
14	30200484	2K	1/10W	1% MF	0603	R99 R100 R763 R764 R765 R766 R767 R768 R1016 R1017 R1018 R1019 R1020 R1021
2	30200485	1.65K	1/10W	1% MF	0603	R138 R1034
2	30200486	221	1/10W	1% MF	0603	R191 R962
3	30200495	22.1	1/10W	1% MF	0805	R710 R711 R802
2	30200496	100	1W	5% MF	2512	R85 R1030
4	30200524	2.26K	1/4W	1%	0603	R131 R132 R133 R134
1	30200526	39.2	1/4W	5% MF	1206	R147
6	30200527	15K	1/10W	1%	0603	R25 R26 R27 R28

			R29 R44
2	30200534	499K 1/10W 1% 0805	R106 R146
5	30200538	150K 1/10W 1% 0805	R67 R68 R107 R108 R109
1	30200539	33.2K 1% 1/10W 0603	R173
6	30200540	3.01K 1% 1/10W 0603	R76 R96 R604 R756 R861 R862
4	30200543	47.5 1/10W 1% 0805	R136 R140 R172 R804
2	30200550	4.7 1/10W 1% 0603	R117 R118
5	30200553	4.99K 1% 1/10W 0603	R103 R575 R576 R887 R888
6	30200623	46.4K 1/10W 1% MF 0603	R125 R126 R187 R188 R189 R190
4	30200641	5.62K 1/10W 1% THKF 0603	R101 R102 R807 R808
3	30200643	12.1K 1/10W 1% THKF 0603	R63 R301 R302
2	30200644	332K 1/10W 1% THKF 0603	R805 R806
2	30200645	121 1/10W 1% THKF 0603	R62 R119
10	30200647	4.42K 1/10W 1% THKF 0603	R97 R98 R121 R122 R642 R643 R644 R646 R648 R649
10	30300069	0.22UF 50V 10% X7R 1206	C35 C36 C37 C38 C39 C40 C486 C487 C488 C489
1	30300085	0.1UF 50V 20% Z5U 0805	C149
5	30300089	220PF 50V 5% NPO 0805	C56 C57 C566 C567 C568
5	30300108	10UF 35V +80,20% Y5V 1210	C54 C55 C563 C564 C565
1	30300115	2200PF 50V 10% X7R 0805	C255
2	30300124	0.01UF 50V +80,20% Y5V 0603	C60 C610
91	30300128	0.1UF 50V +80/-20% Y5V 0603	C12 C13 C42 C48 C49 C50 C51 C52 C53 C102 C103 C104 C105 C106 C107 C108

C109 C110 C111 C112
C113 C114 C115 C116
C117 C118 C119 C120
C121 C123 C124 C125
C126 C127 C128 C129
C130 C131 C132 C133
C134 C135 C136 C137
C138 C139 C140 C141
C142 C143 C144 C145
C146 C147 C148 C152
C153 C154 C155 C156
C157 C158 C159 C160
C161 C162 C163 C164
C165 C166 C167 C168
C169 C170 C171 C172
C173 C174 C175 C176
C177 C178 C179 C180
C182 C183 C205 C206
C210 C254 C619

C492 C560

C4 C26 C27 C28
C29 C310 C311 C315
C316 C333 C334 C335
C336 C616 C617 C618

C500 C501 C502 C503

C30 C31 C312 C313
C314 C337 C338 C339
C340 C341 C342 C583
C584

C289 C290 C291 C292

C569 C570

C45

C343 C344 C346 C347
C348 C585 C586 C587
C588 C612

C184 C185 C613

C25

C527 C528 C529 C530

C497 C498

2 30300130 1UF 25V +80/-20% Y5V 1206
16 30300133 100PF 50V 5% NPO 0603
4 30300134 1800PF 50V 10% X7R 0603
13 30300141 390PF 50V 5% NPO 0603
4 30300148 0.022UF 50V 5% X7R 0805
2 30300150 22PF 50V 5% NPO 0805
1 30300152 100UF 16V 20% EL LOZ SMT6
10 30300160 1000PF 50V 5% NPO 0603
3 30300170 330PF 100V 5% NPO 0805
1 30300171 0.047UF 50V 5% X7R 0805
4 30300176 0.068UF 50V 5% X7R 0805
2 30300210 15PF 50V 5% COG 0603

4	30300212	150PF 100V 5% NPO 0603	C198 C199 C200 C201
14	30300220	39PF 50V 5% NPO 0603	C194 C195 C244 C245 C246 C247 C248 C249 C250 C251 C252 C253 C614 C615
2	30300222	470PF 50V 5% NPO 0603	C5 C6
2	30300237	22UF 16V 20% EL SMT4	C58 C59
1	30300245	1500PF 50V 5% NPO 0805	C41
4	30300256	47PF 50V 5% NPO 0603	C196 C197 C531 C532
2	30300257	20PF 50V 5% NPO 0603	C2 C3
2	30300258	2.2UF 25V 10% X7R 0805	C7 C8
1	30300270	150NF 50V 5% X7R 0805	C34
7	30300324	10UF 6.3V 10% X5R 0603	C504 C505 C506 C507 C508 C509 C510
1	30300325	22UF 16V 10% X5R 1206	C256
4	30300350	0.01UF 50V 5% X7R 0603	C579 C580 C581 C582
4	30320181	22UF 50V 20% EL RAD	C533 C534 C575 C576
7	30320182	47UF 50V 20% EL RAD	C23 C24 C227 C277 C278 C279 C280
4	30320184	2.2UF 50V 20% ELN RAD	C150 C151 C484 C485
6	30320185	10UF 50V 20% ELL RAD	C18 C224 C225 C226 C490 C491
1	30320187	220UF 50V 20% EL RAD	C535
2	30320324	470UF 25V 20% ELS RAD	C561 C611
63	30320344	47UF 35V 20% EL RAD	C9 C10 C11 C14 C15 C16 C17 C19 C20 C21 C22 C32 C33 C46 C47 C204 C209 C404 C405 C406 C407 C408 C409 C410 C411 C412 C413 C414 C415 C416 C417 C418 C419 C420 C421 C422

					C423 C424 C425 C426 C427 C428 C429 C430 C433 C434 C435 C436 C437 C438 C439 C440 C441 C442 C443 C444 C445 C446 C447 C448 C449 C450 C451
1	30320623	47UF	63V 20% EL	RAD	C562
4	30320625	100UF	25V 20% EL	RAD	C1 C43 C44 C122
4	30330133	0.12UF	50V 5% PE	RAD	C493 C494 C495 C496
2	30400979	24V ZENER (SOD123)-SMT			D1 D2
1	30409216	16 X 2 BLUE, WHITE CHARACTERS			DISPLAY1
1	30418005	4053 3- 2:1 ANALOG SW SMT			U63
22	30418026	1N4148 (LL34) DIODE SMT			D52 D53 D143 D144 D145 D146 D147 D148 D149 D150 D151 D152 D156 D157 D158 D159 D160 D161 D162 D163 D164 D165
4	30418051	MMBTA13LTI NPN DARL. SMT			Q11 Q12 Q13 Q14
12	30418135	2N3904 NPN SOT23			Q3 Q15 Q16 Q17 Q18 Q19 Q20 Q21 Q22 Q23 Q24 Q35
1	30418136	MMBT5401 PNP SOT23			Q38
1	30418137	2N5551 NPN SOT23			Q41
2	30418138	J111 JFET N SOT23			Q1 Q2
2	30418140	6.8V ZENER (SOD123)-SMT			D74 D75
1	30418141	1N758 10V ZENER SOD123			D5
2	30418219	SCHOTTKY 40V 1A SMT			D7 D8
6	30418284	MMBT2907 PNP SOT23			Q4 Q33 Q34 Q36 Q37 Q39
1	30418363	MBS360T3 SCHOTTKY 60V 3A			D48
1	30418402	12V ZENER (SOD123)-SMT			D4

1	30418499	FCX493 100V 1A NPN SMT	Q40
1	30418587	PCM2903C ST CODEC W/USB SMT	U64
2	30418588	74HC595PW 8-TRI SHIFT REG SMT	U65 U66
1	30418593	TC7SZ08F SINGLE AND SOT23-5	U70
6	30418649	LM339 QUAD COMPARATOR TSSOP	U52 U53 U54 U71 U72 U73
11	30418655	BAV99L DUAL 4148 DIODE SO	D3 D46 D59 D60 D61 D62 D63 D64 D66 D67 D155
2	30418668	74HC165 PARALLEL-IN/SERIAL OUT	U68 U69
1	30418807	SPX1117 LDO ADJ VREG SMT	U1
1	30418943	ST1S14 3A SYNC ADJ SW REG SMT	U67
30	30418958	4580C DUAL LN OPAMP SO8	U32 U33 U34 U35 U36 U37 U38 U39 U40 U41 U42 U43 U44 U45 U46 U47 U48 U49 U50 U51 U55 U56 U57 U58 U59 U60 U61 U62 U74 U75
1	30418960	2SA2040 LO VCE PNP TO-252	Q58
1	30418967	16V 1.5W ZENER SMA	D6
1	30419242	3A 600V FAST RECOVERY RECT	D49
1	30419248	SCHOTTKY 40V 1A SOD-123	D166
1	30419297	TVS ARRAY LOW-CAP USB 2.0	D58
4	30450050	RED T1 LED W/.500" SPCR	D33 D36 D42 D44
2	30450051	GRN T1 LED W/.500" SPCR	D34 D37
7	30450052	YEL T1 LED W/.500" SPCR	D35 D38 D39 D40 D41 D43 D45
2	30450837	RED RECT LED W/0.390" SPACER	D181 D193
16	30450838	GRN RECT LED W/0.390" SPACER	D170 D171 D172 D173 D174 D175 D176 D177 D182 D183 D184 D185 D186 D187 D188 D189

6	30450839	YEL RECT LED W/0.390" SPACER	D178 D179 D180 D190 D191 D192
1	30500926	COMMON MODE F-BEAD	L1
8	30500935	FERRITE CHIP SMT 600OHM 1.3A	L2 L3 L4 L5 L6 L7 L8 L12
1	30518738	3.3UH IND 4.6A SHIELDED SMT	L9
1	30519995	10UH IND 4.5A SHIELDED SMT	L10
1	30600520	4C 2.5MM WPCB WPCB 2.25"	P7
1	30800045	CRYSTAL 12MHZ SMT	Y1
1	30901785	SCREW TERM, 6-32 -PCB MT	P5
2	31190258	10KB SNGL 9MM VER	VR88 VR90
2	31190266	50KB SNGL 9MM VER	VR73 VR80
2	31190710	10KA/C DUAL 12MM DET VER	VR74 VR81
11	31190711	10KB DUAL 12MM VER	VR69 VR76 VR83 VR84 VR85 VR86 VR87 VR89 VR91 VR92 VR95
4	31190716	50KB DUAL 12MM DET VER	VR70 VR72 VR77 VR79
2	31190717	10KB DUAL 12MM DET VER	VR71 VR78
2	31191064	10K_ DUAL 60MM VER	VR75 VR82
2	31191065	10K_ SNGL 60MM VER	VR93 VR94
1	31322321	SWITCH, DPDT PC MNT SLIDE	S49
1	31322341	SWITCH DPDT PP 2.8MM PC H	S58
6	31322356	SWITCH DPDT 2.8MM SHFT V	S39 S42 S43 S44 S46 S47
5	31322360	SWITCH 4PDT 2.8MM SHFT V	S38 S41 S45 S48 S57
5	31322361	SWITCH DPDT 2.8MM MOM V	S50 S51 S52 S53 S56
1	31322453	SWITCH 2P3T SLIDE PC V 9MM	S40
2	31322479	ENCDR 24P 24D 2BIT SW PC V	S54 S55
1	31466223	JACK, STEREO R/A 1/4" 6.5MM	J31

1	31466267	DC POWER JACK W/O EARS	J32
1	31466473	QUAD NICKEL RCA JACK 14MM	J30
8	31466543	STEREO HID JACK NINS W/SPD	J18 J19 J22 J23 J24 J25 J26 J27
3	31466553	MXLR A-SER VERT PIN4 SHELL	J21 J28 J29
1	31466557	JACK, 3.5MM PHONE HI-D	J17
1	31466615	DUAL RCA 14MM VERT WH-RD	J20
1	33715222	USB B HOR	P6
3	33716928	8 HDR V SR 2.5MM TIN	P9 P10 P11
1	33719149	16 FLT FLX 1.0MM CONN TH	P4
3	33719217	16 FFC 1.0MM ZIF HORZ BOT SMT	P1 P2 P8

 END OF BILL OF MATERIAL REPORT
