

# Hot Rod Tweed Conversion for SF Bassman Head

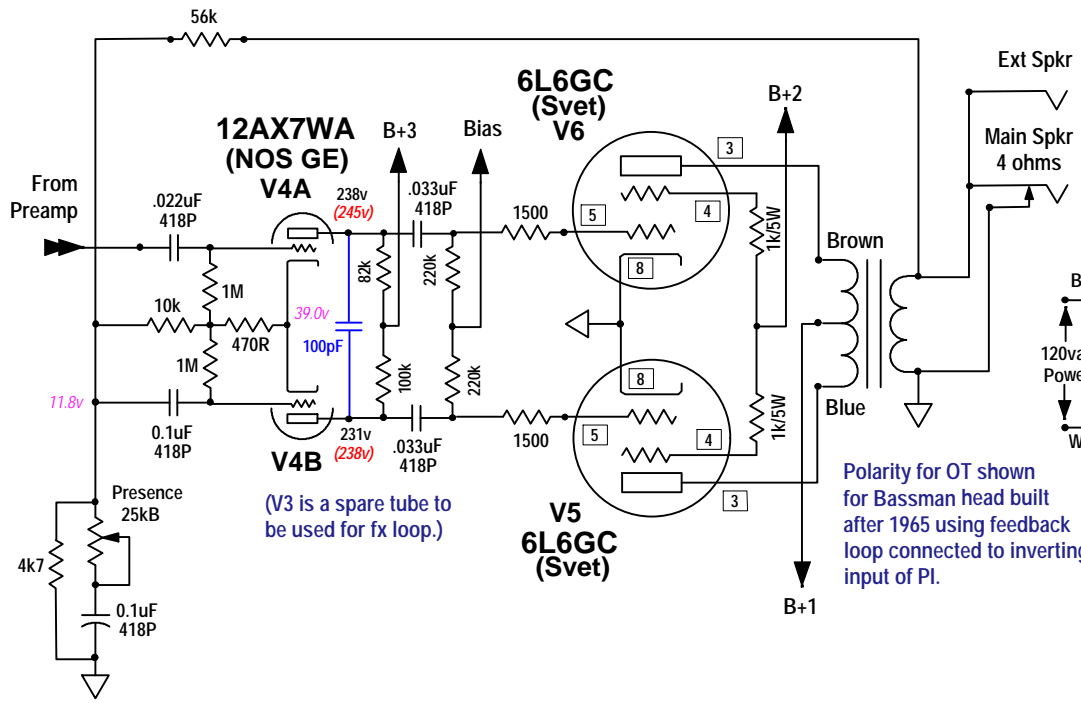

Notes:  
 Wiring for optional tube rectifier & switch shown on layout drawing  
 Tube rectifier voltages in Black  
 SS rectifier voltages in Red *Italic*  
 418P = Orange Drop cap  
 SM = Silver Mica cap

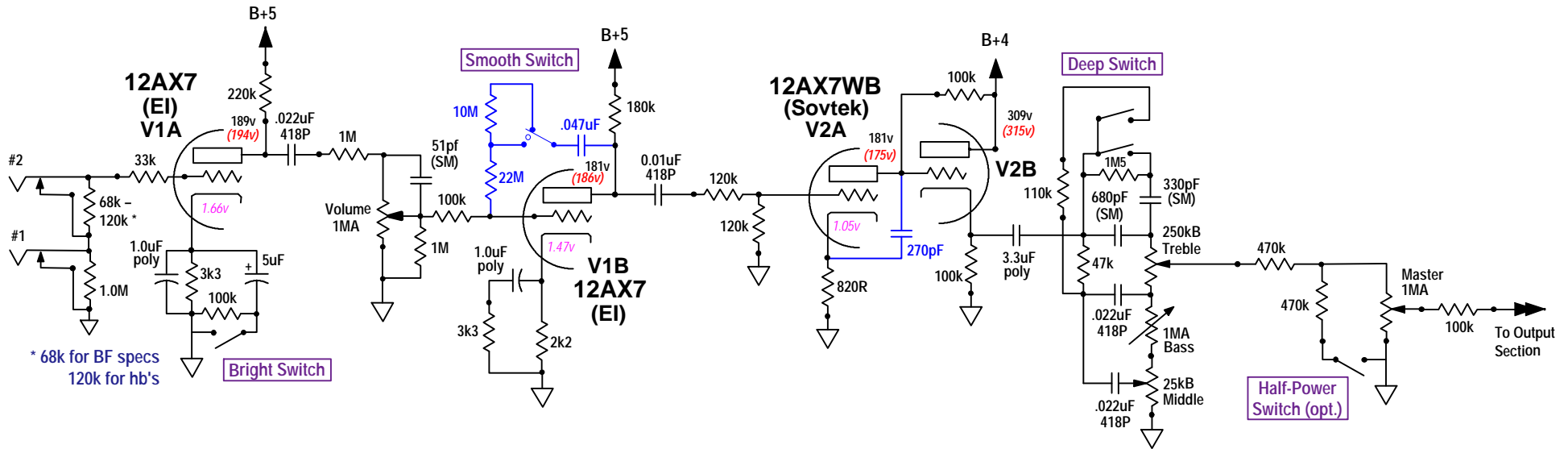
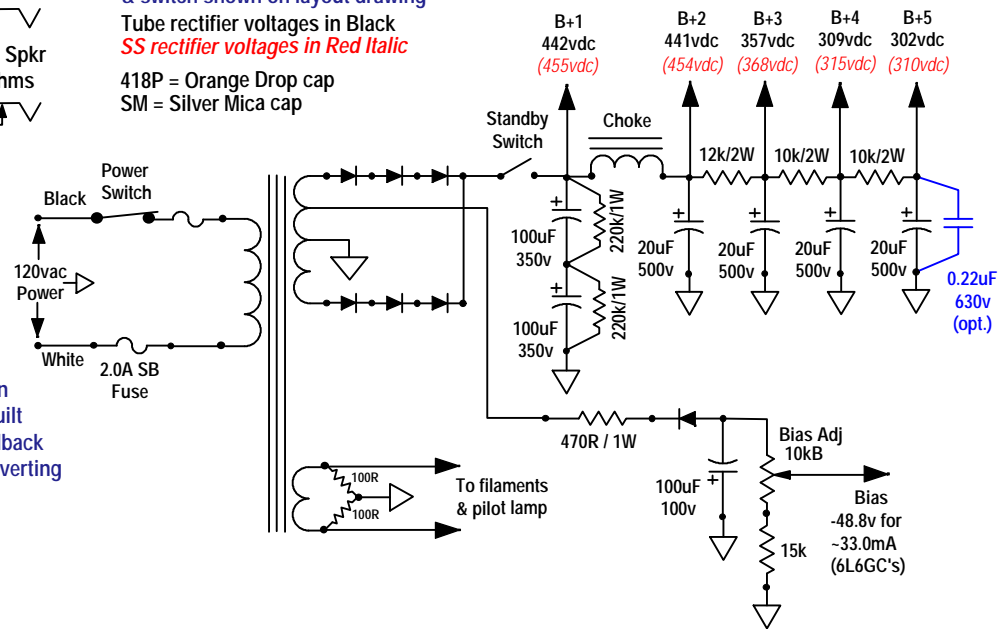

Blues Master variation

Designed by Steve Ahola  
 Rev.03-01-00