

ECHO CHAMBER

RE-201/101

SERVICE NOTES

CONTENTS

SPECIFICATIONS (RE-201/101)	1
RE-201	
PCB CHANGES	2
BLOCK DIAGRAM	2
MINIATURE BOARD OP-13 / ECHO BOARD OP-14B / FILTER BOARD FL-7	3
OP-16/OP-14B/FL-7 / CIRCUIT DIAGRAM	4
POWER SUPPLY PS-15D (SERIAL NO. 576450 AND HIGHER)	5
POWER SUPPLY PS-15D CIRCUIT DIAGRAM	6
POWER SUPPLY PS-15C (SERIAL NO. UP TO 576449)	7
POWER SUPPLY PS-15C CIRCUIT DIAGRAM	8
RE-101	
PCB CHANGES	9
BLOCK DIAGRAM	9
MINIATURE BOARD OP-16 / ECHO BOARD OP-17B / FILTER BOARD FL-7 / CIRCUIT DIAGRAM	10
RE-201/101	
MOTOR REPLACEMENT	11
TAPE PACK CHASSIS ASSEMBLY	12
ADJUSTMENT AND CHECKING	
1. MECHANICAL ADJUSTMENT	13
2. ELECTRICAL ADJUSTMENT	15
PARTS	19
PARTS LIST	21

SECOND EDITION July 30, 1978

All of the information contained in
the first edition and the supplement
is collected in this second edition.

SPECIFICATIONS

JUL 30 1978 RE-201/101

SPECIFICATIONS

	RE-201	RE-101
Supply Voltage	100/117/220/230/240V, 50/60Hz	
Power Consumption	16W	15W
Dimensions	415(W) x 275(D) x 185(H)mm	16.5(W) x 10.8(D) x 7.3(H)in
Weight	9.5Kg, 2.1 lbs.	9.2Kg, 2.0 lbs.
Accessories	Connection Cord (2) Foot Switch (FS-1) Endless Tape (RT-1) Cleaner Vinyl Cover	
S/N Ratio	60dB - "A" weighted	

INPUT

	MIC	INSTRUMENT	FROM PA
Input Level	-50dBm(2.4mV)	-24dBm(44mV)	-24dBm(44mV)
Input Impedance	0.9Kohm	16Kohm	100Kohm

OUTPUT

	H	M	L
Output Level	-15dBm(140mV)	-23dBm(54mV)	-35dBm(14mV)
Output Impedance	1.4Kohm	1.5Kohm	0.5Kohm

RE-201

MOTOR

Initially — CDM-131019 (not available now)
 Serial No. 331200 and higher — M-502E-B02
 See page 8 for replacing CDM-131019 by M-502E-B02.

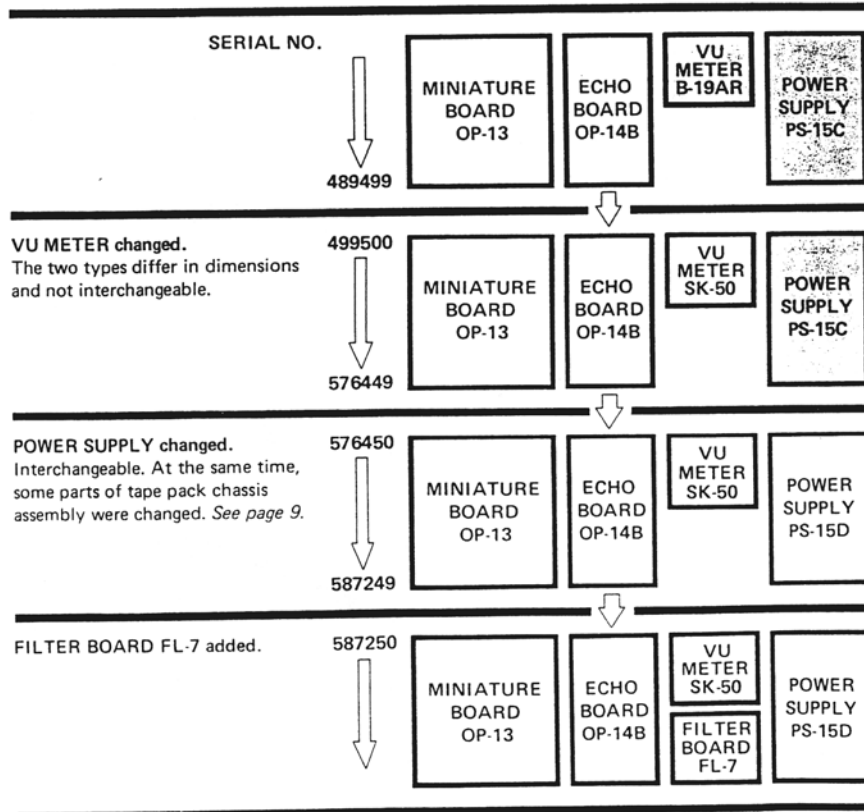

When ordering parts, never fail to declare:
 (1) Model, (2) Serial No., (3) Parts No. and (4) Parts Designation and/or Rating.

BLOCK DIAGRAM

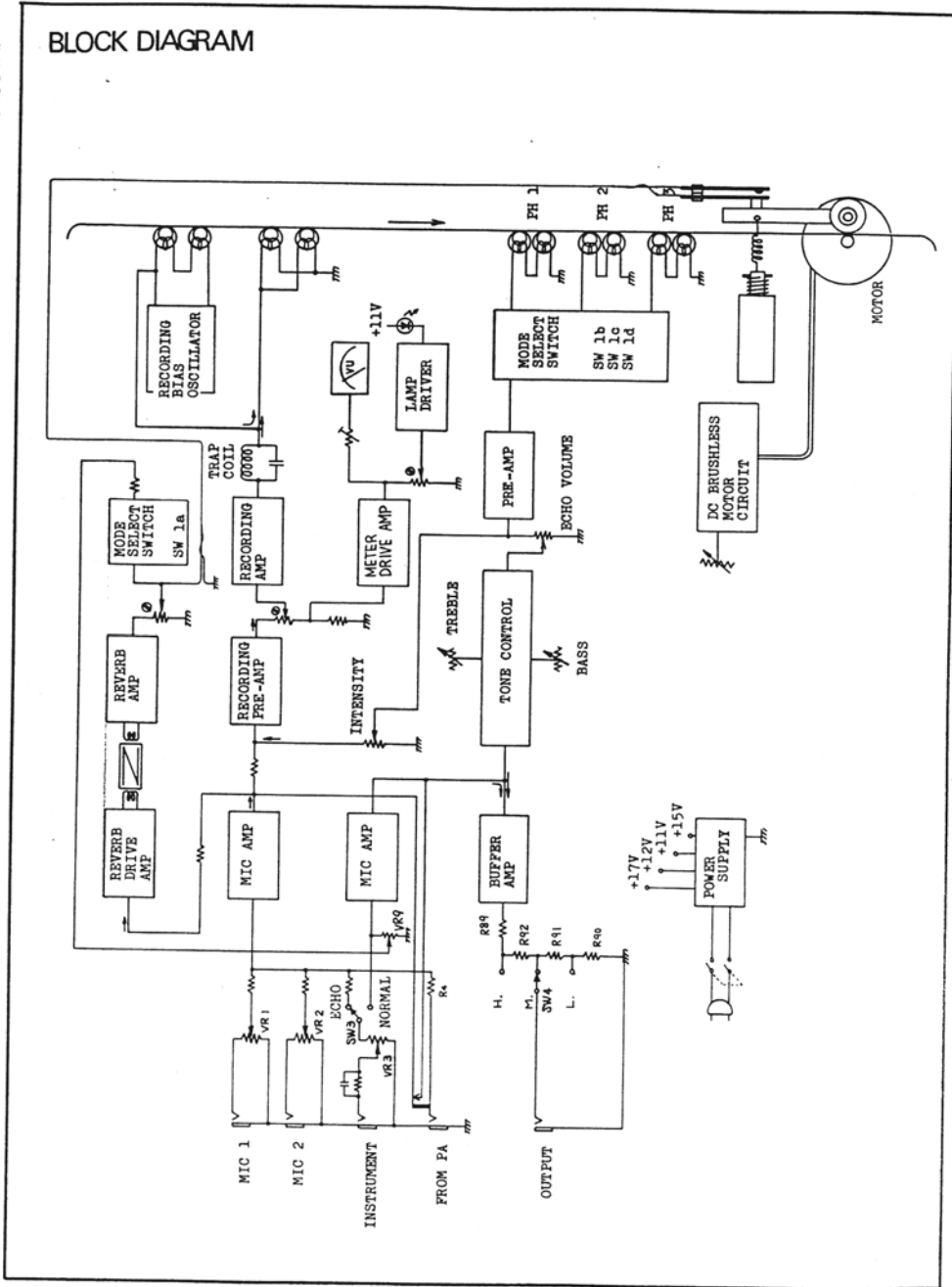

MINIATURE BOARD OP-13 (149-013)

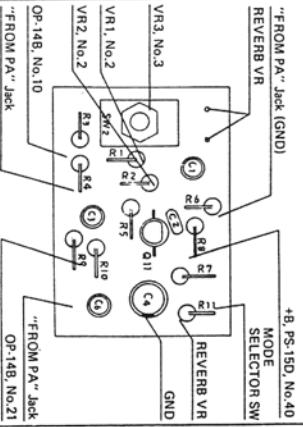

SW2: 6A-1011 (Serial No. 588100 and higher)
 SW1: 6A-1011 (Serial No. 588100 and higher)
 Reversible by slightly modifying the mounting hole.

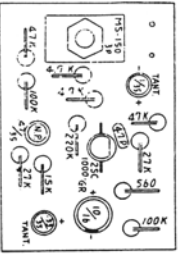

VIEWED FROM FOIL SIDE

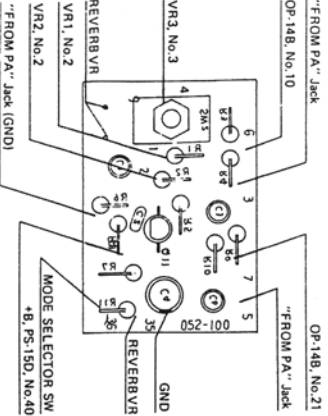

ECHO BOARD OP-14B (149-014B)

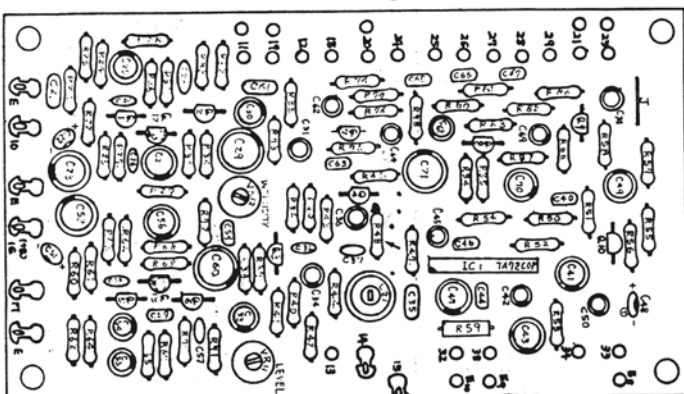
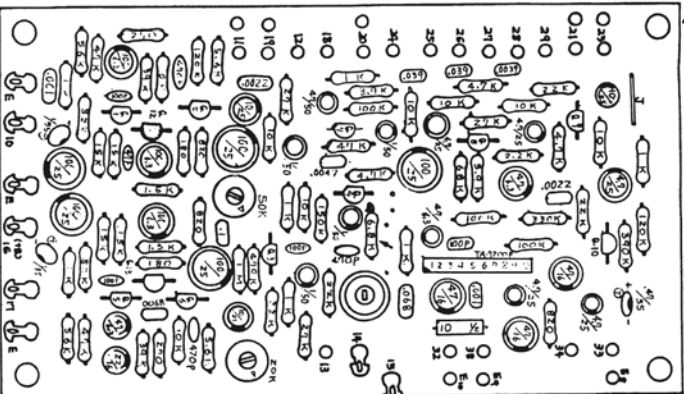
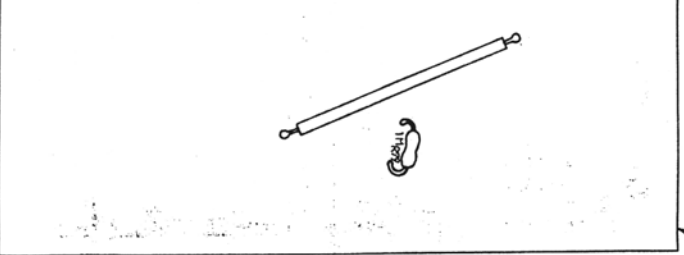

- T1-10 25C-1000 GR
- T1-12, 13 25A483 GR
- Tantalum Capacitor

FILTER BOARD FL-7 (145-007)
 For Serial No. 587250 and higher

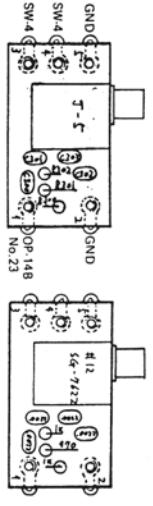

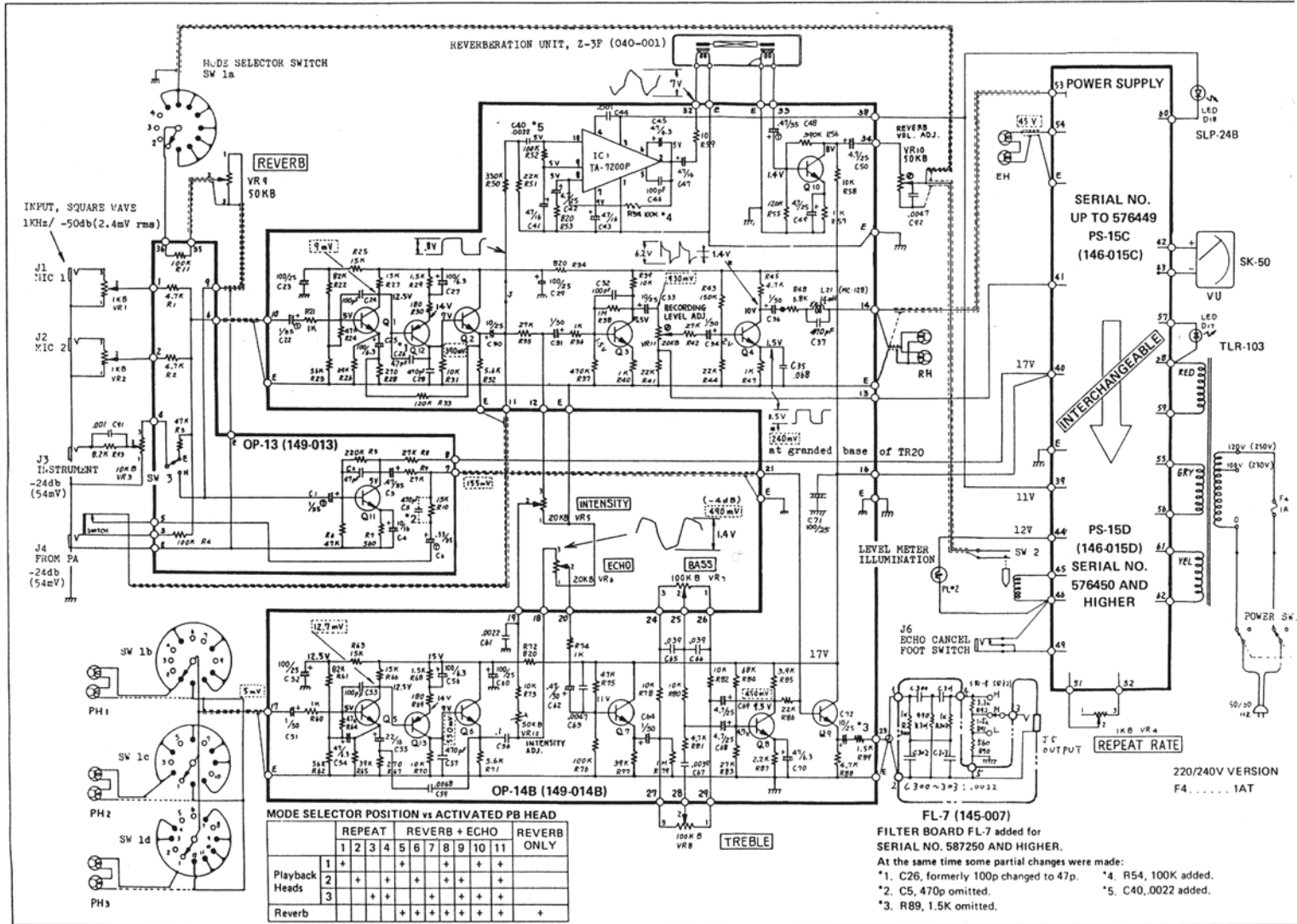

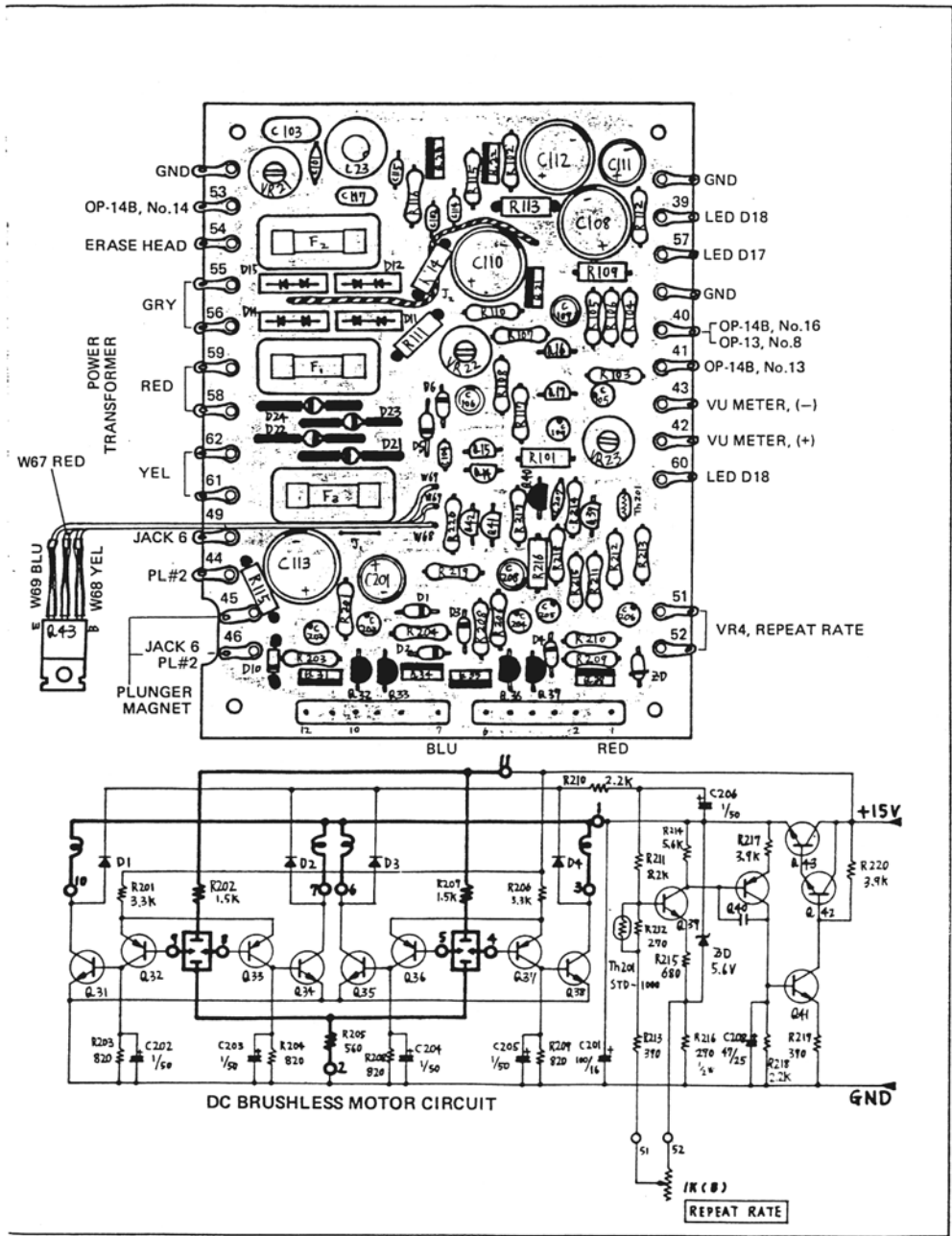

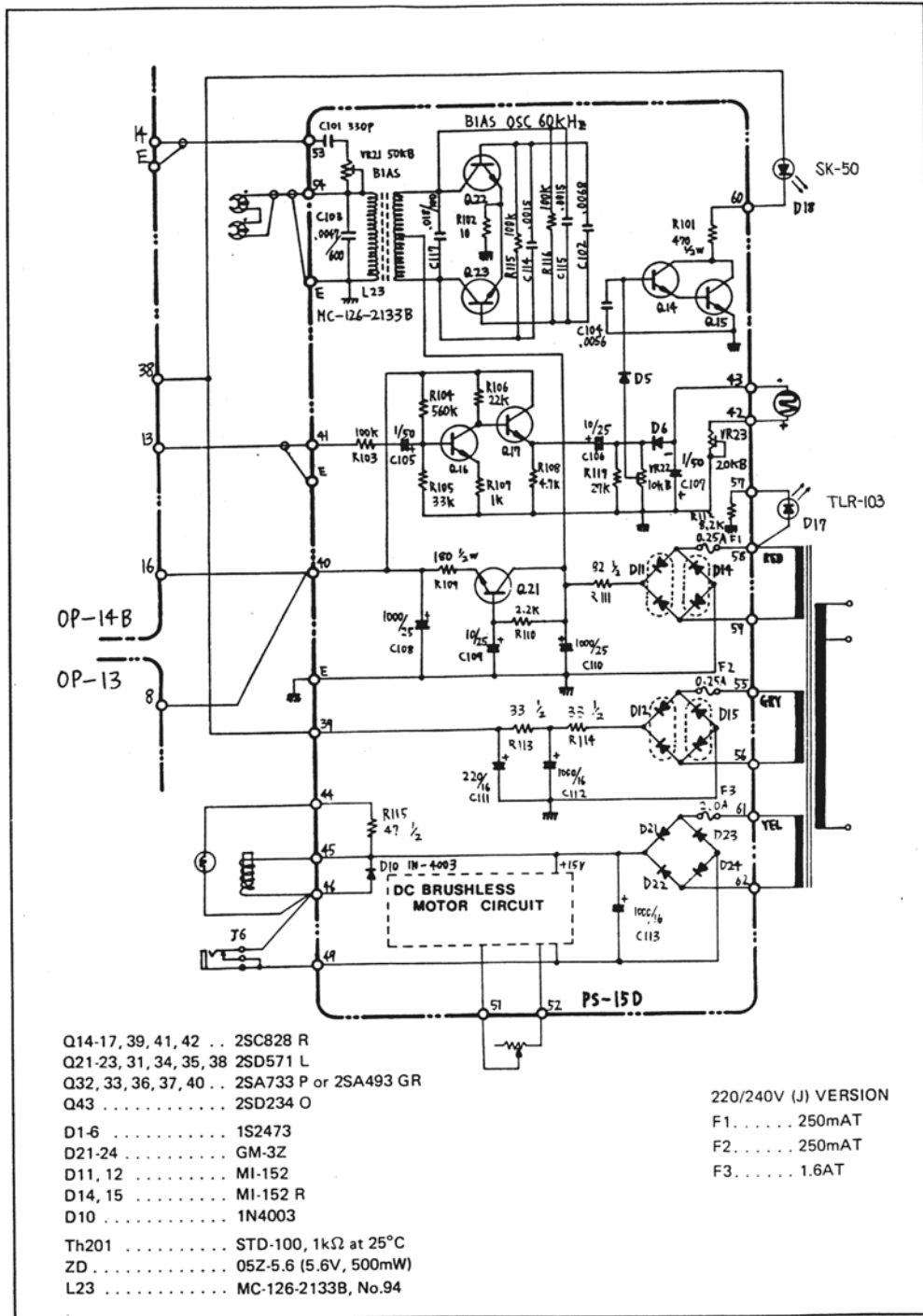



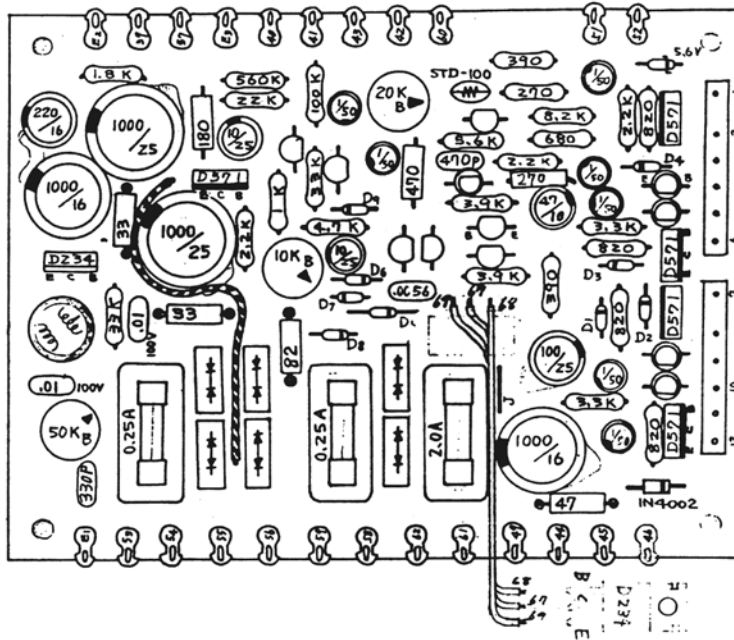



POWER SUPPLY PS-15C (146-015C)



-  E 2SC828 R
-  E 2SA733 P or Q
-  E C B 2SD571 L or 2SD414
-  MI-152R
-  MI-152
-  1S-2473

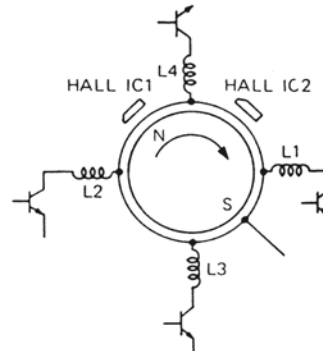

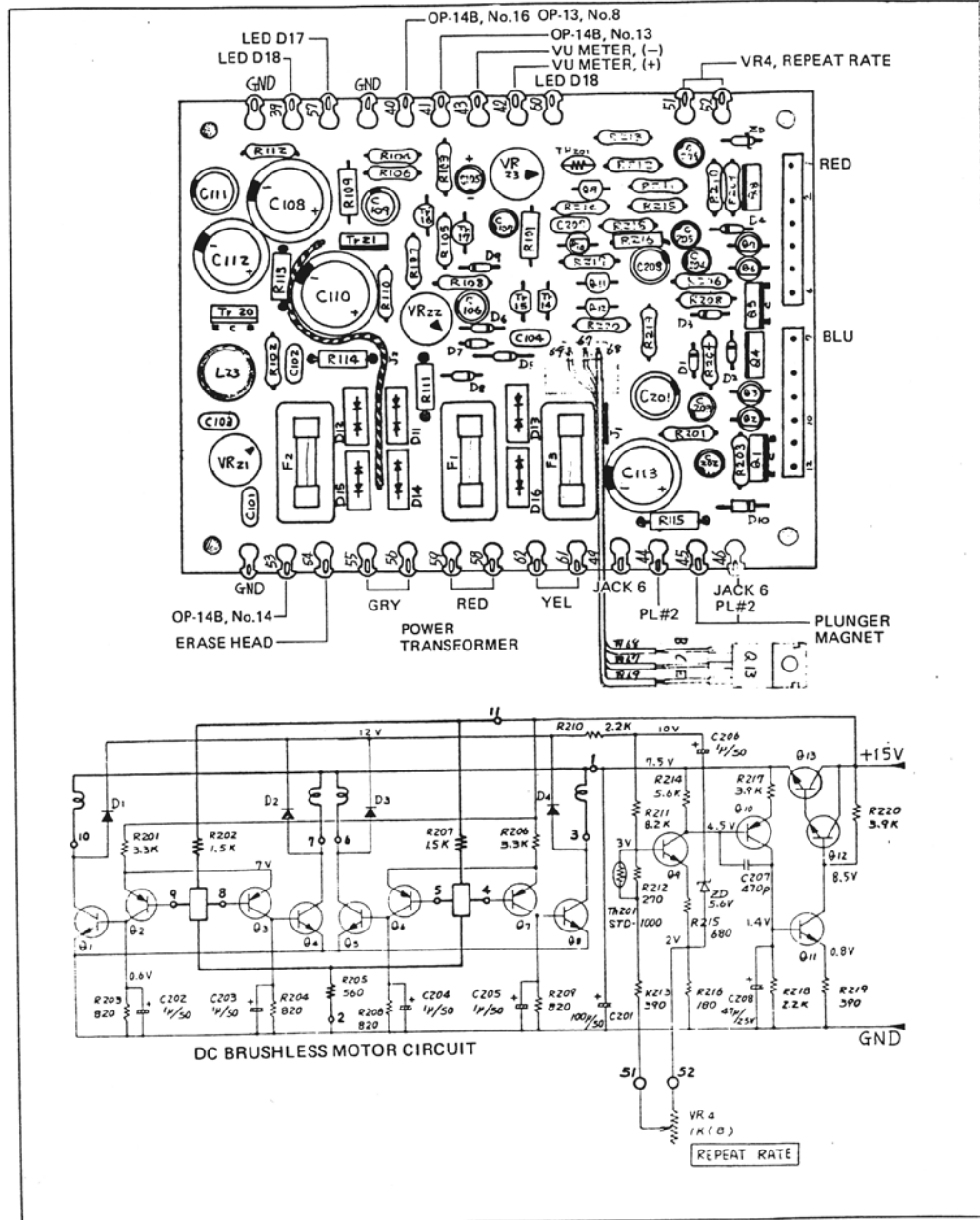

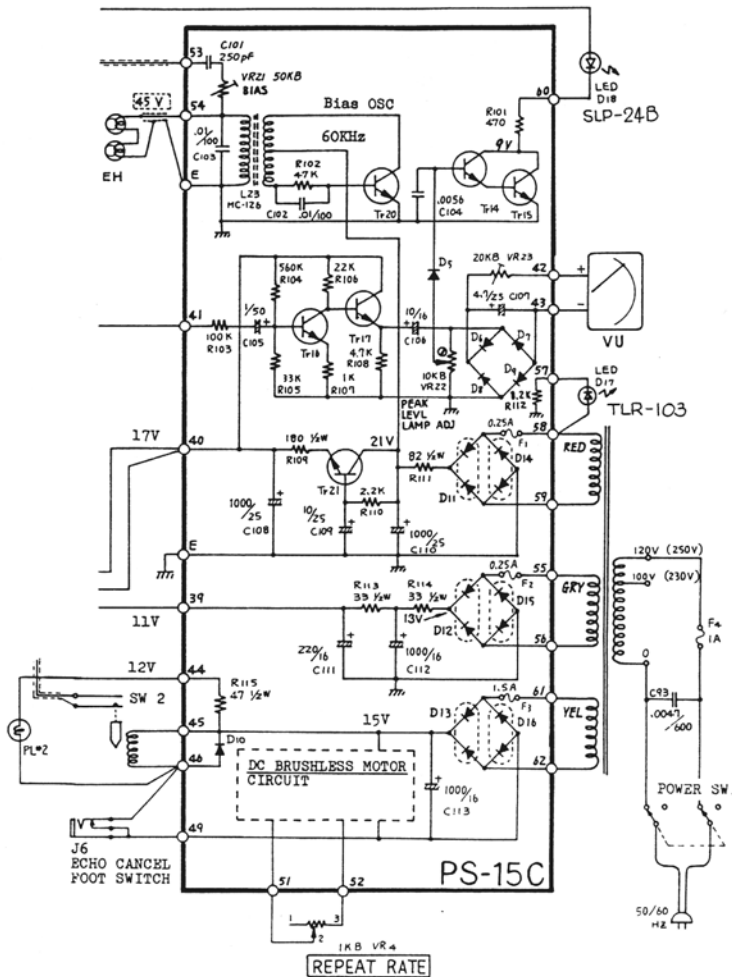

- Tr14-17, Q9, 11, 12 . . . 2SC828 R
- Tr20, Q13 2SD234 O
- Tr21, Q1, 4, 5, 8 . . . 2SD571 L or 2SD414 Q^{*1}
- Q2, 3, 6, 7, 10 2SA493 GR or 2SA733 P
- D1-9 1S2473
- D10 1N4002
- D11-13 1S1850 (CSA) or MI-152
- D14-16 1S1850 (CSA) or MI-152 R
- L23 MC-126, No.46

(*1) Q1, 4, 5, and 8 must be same class of same transistor.

RE-101

MOTOR
 Initially — CDM-131019 (not available now)
 Serial No. 330300 and higher — M-502E-B02
 See page 8 for replacing CDM-131019 by M-502E-B02.

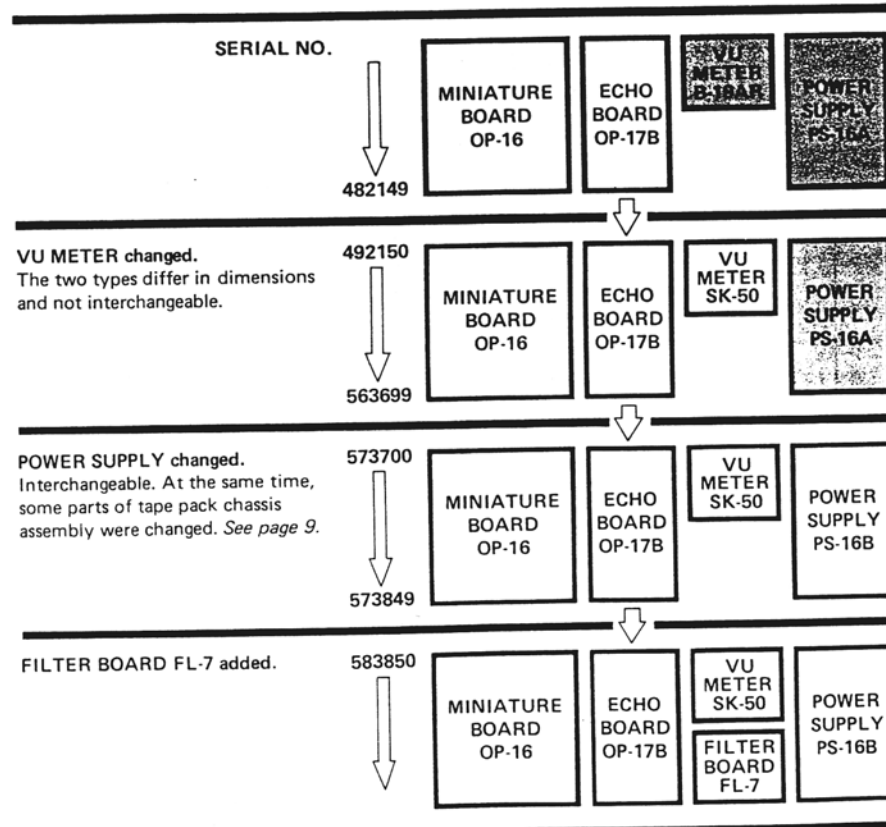

When ordering parts, never fail to declare:
 (1) Model, (2) Serial No., (3) Parts No. and (4) Parts Designation and/or Rating.

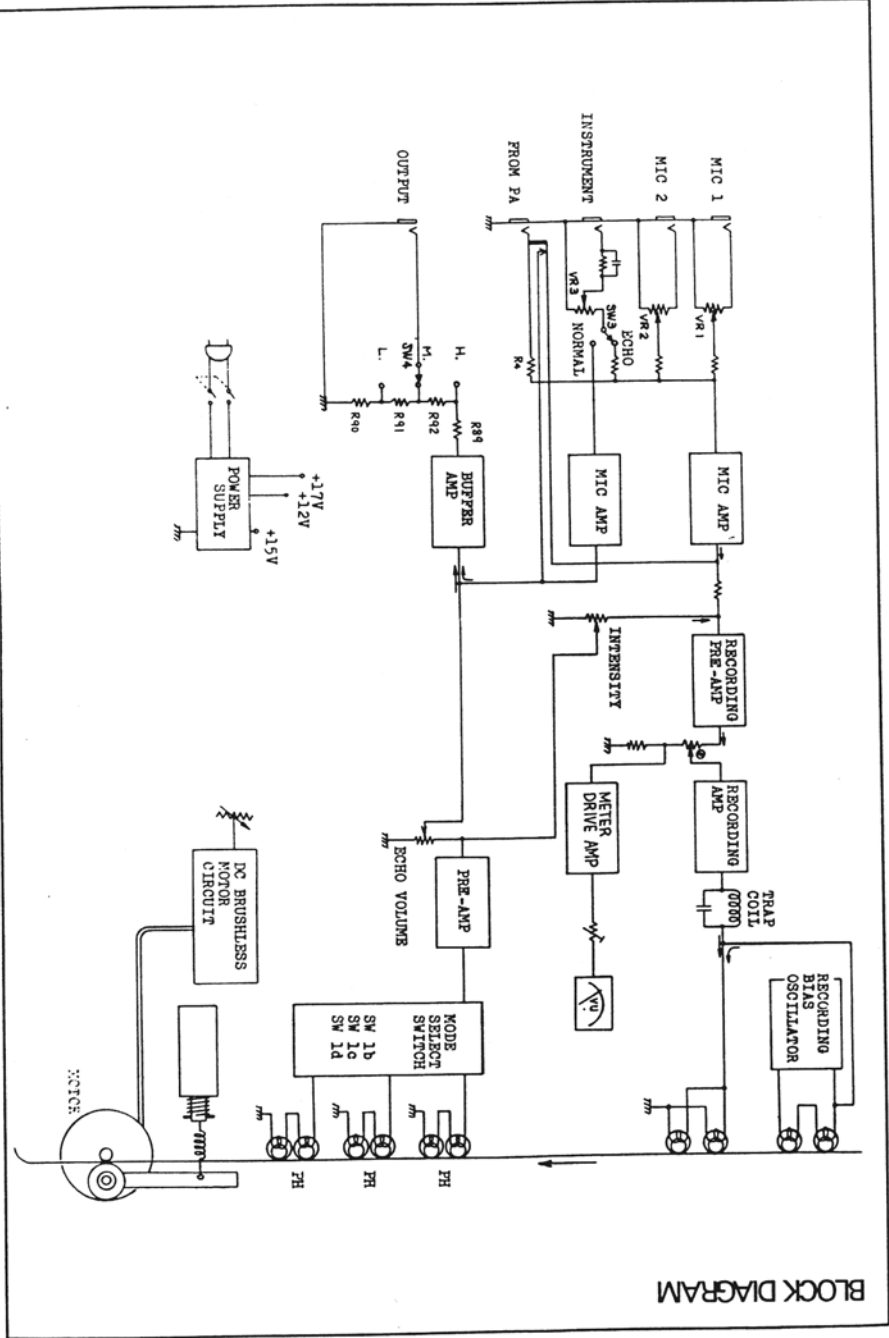

BLOCK DIAGRAM

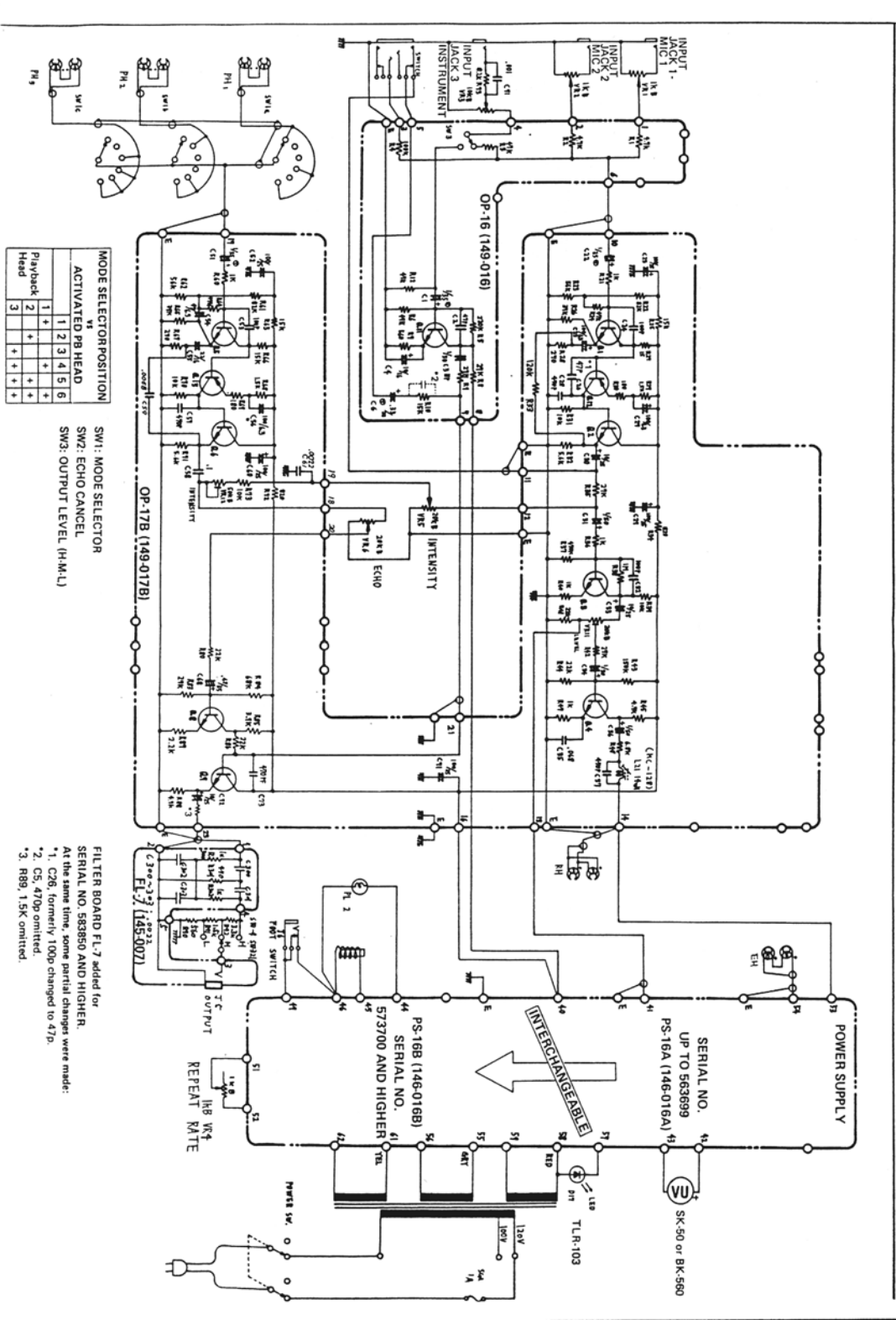

SM1: MODE SELECTOR
 SM2: ECHO CANCEL
 SM3: OUTPUT LEVEL (H.M.L.)

MODE SELECTOR POSITION

1	2	3	4	5	6
+	+	+	+	+	+
+	+	+	+	+	+
+	+	+	+	+	+

ACTIVATED PB HEAD

1	2	3	4	5	6
+	+	+	+	+	+
+	+	+	+	+	+
+	+	+	+	+	+

Playback Head

1	2	3
+	+	+
+	+	+
+	+	+

FLTR BOARD FL-7 added for SERIAL NO. 583850 AND HIGHER.
 At the same time, some partial changes were made:
 *1. C26, formerly 100p changed to 47p.
 *2. C5, 470p omitted.
 *3. R89, 1.5K omitted.

MOTOR REPLACEMENT

TO REPLACE MOTOR CDM-131019 BY M-502E-802
 Motor CDM-131019 that was initially used is no more available. If it is necessary to replace the motor, use M-502E-802. Mount it by use of an adaptor as shown in the photo below and by adding a motor circuit adaptor as shown on the left.

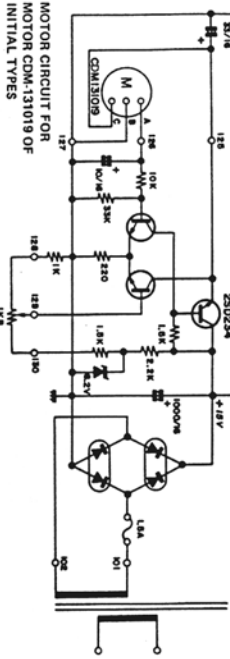

MOTOR CIRCUIT FOR MOTOR CDM-131019 OF INITIAL TYPES

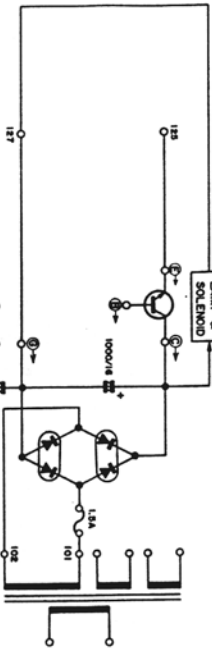

CONNECT FROM POINTS ENCIRCLED TO CORRESPONDING TERMINALS OF MOTOR CIRCUIT ADAPTOR.

MOTOR CIRCUIT ADAPTOR

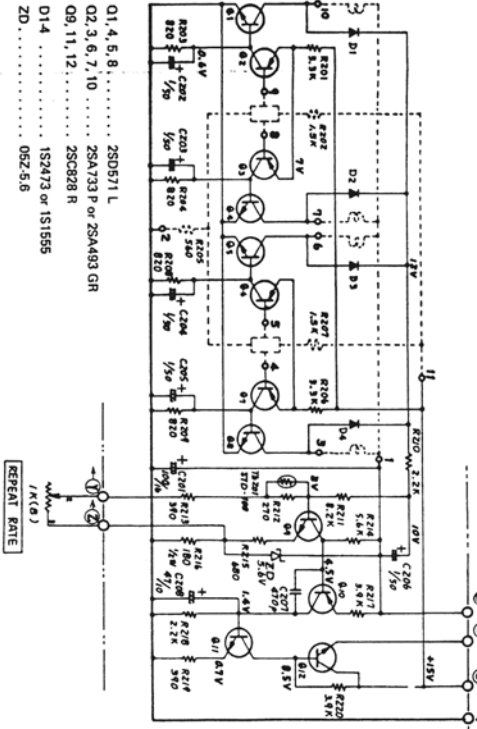

Mount motor M-502E-802 by use of an adaptor.
 Secure it with four 4p bolts.

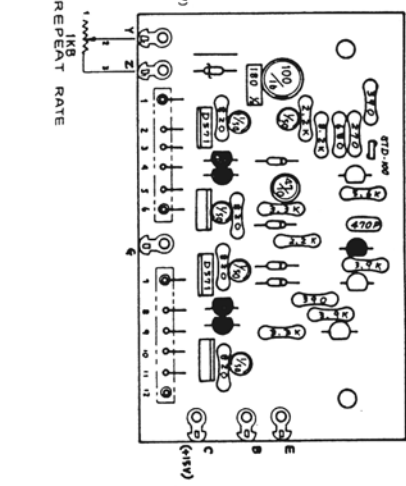
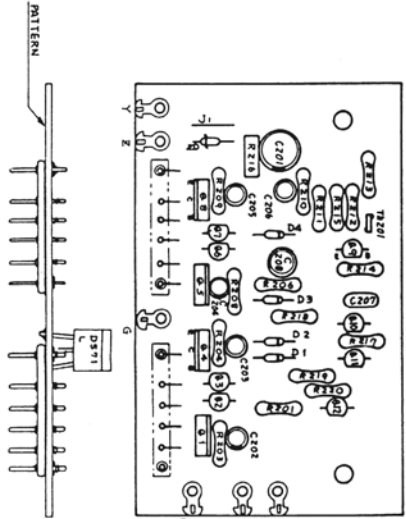
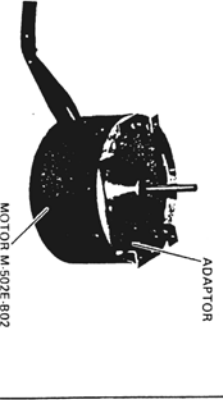

TAPE PACK CHASSIS ASSEMBLY

This drawing shows tape pack chassis assembly for SERIAL NO. 573700 AND HIGHER.
For SERIAL NO. UP TO 563699, parts encircled slightly differ.
They can be interchangeable except for (11) and (15) that should be replaced as a set.

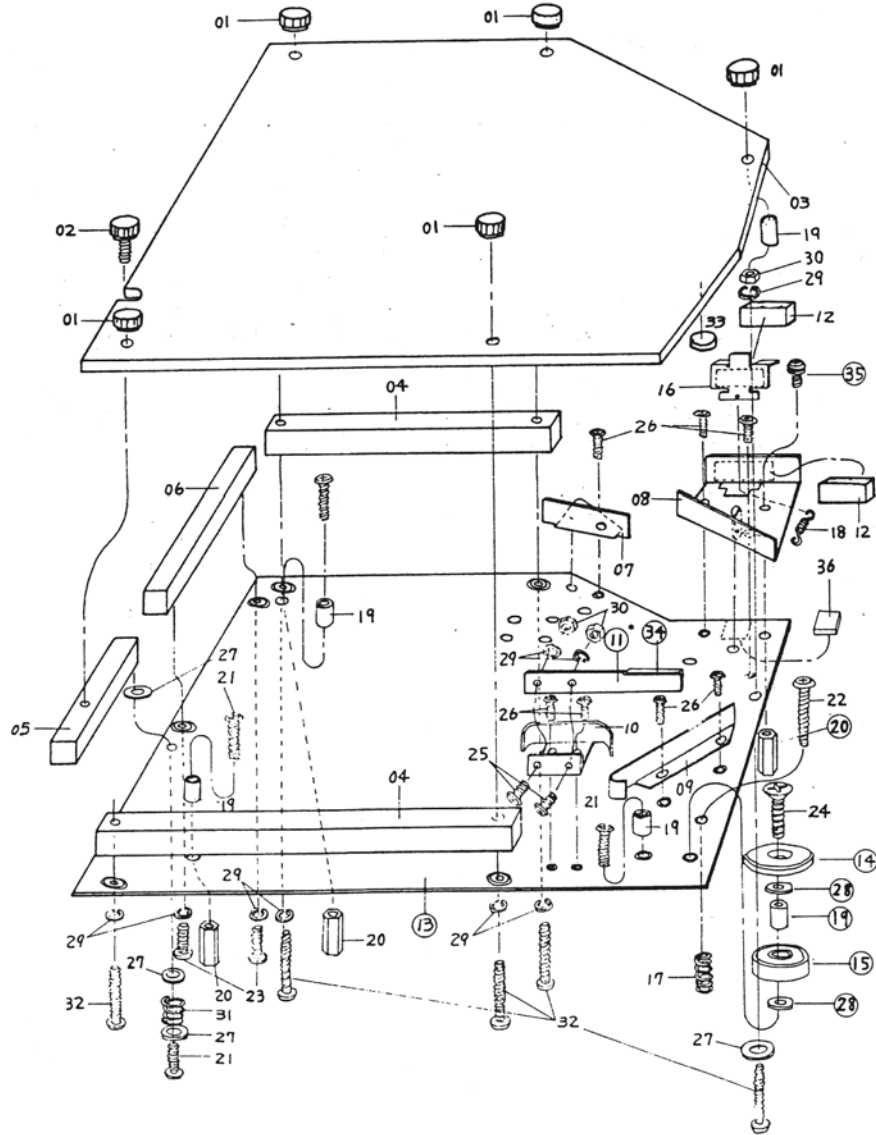

TAPE PACK CHASSIS ASSEMBLY

NO.	PARTS NO.	PARTS NAME AND DESCRIPTION
01	120-036	Nut, Decoration, M3
02	123-004	Screw, Decoration, M3
03	092-004	Top cover No.4, pack (acrylic)
04	079-004	Frame No.4
05	079-005	Frame No.5
06	079-006	Frame No.6
07	079-007	Frame No.7
08	079-008	Frame No.8
09	079-009	Frame No.9
10	079-010	Frame No.10
11	070-033	Leaf spring No.33
12	101-017	Felt No.17
13	061-063A	Chassis No.63A
14	065-113	Cover, Bearing
15	113-004	Bearing
16	063-011	Plate No.11
17	070-017	Spring No.17, Support for chassis
18	070-018	Spring No.18
19	*	Collar (plastic), M3 x 6mm
20	120-001	Sleeve Nut No.1, 10mm
21	*	Screw, B.H. M3 x 12mm, Nickel
22	*	Screw, B.H. M3 x 15mm, Chrome
23	*	Screw, B.H. M3 x 6mm,
24	*	Screw, O.H. M3 x 15mm, Nickel
25	*	Screw, B.H. M3 x 6mm,
26	*	Screw, T.H. M2.6 x 4mm, Nickel
27	*	Plain washer M3 x 8 x 0.5mm
28	121-035	Plain washer No.35, M3 x 8 x 0.3mm Phosphor bronze
29	*	Spring washer M3
30	*	Nut, Hex M3
31	070-005	Spring No.5
32	*	Screw, B.H. M3 x 18mm
33	101-008	Felt Chip No.8
34	101-026	Felt No.26
35	*	Screw, SEMS M3 x 8mm, Chrome (wire spring washer)
36	107-004	Cushion No.4

NOTE: *(15) is slightly smaller in height than older (15). When replacing (15), replace (11), too.

ADJUSTMENT AND CHECKING

1. MECHANICAL ADJUSTMENT

1-1. TAPE CHASSIS POSITION

Adjust the tape chassis position so that the clearance from the motor shaft is 1mm. See Fig.1. Secure it by tightening 2 screws at the rear section of the chassis.

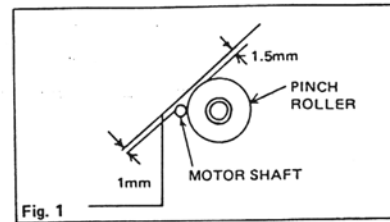

1-2. TAPE CHASSIS HEIGHT (TEMPORARY)

Adjust the tape chassis height so that it is 10.5 ± 0.5 mm above the main chassis. See Fig.2. (Make sure that Frame No.8 is not deformed)

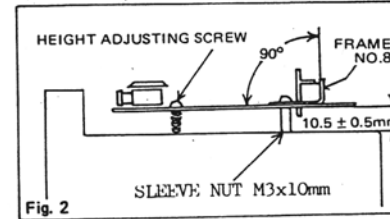

1-3. LEAF SPRING PRESSURE

Adjust position of Frame No.10 so that the tension to separate the leaf spring from the bearing roller is 25-30g. See Fig.3.

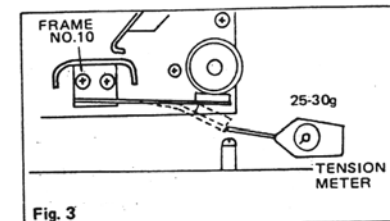

1-4. POSITION OF FRAMES NOS.7,8, AND 9

Secure the frames as illustrated in Fig.4.

CAUTION: Make adjustment of position of Frames Nos. 7 and 8 accurately with the pinch roller in contact with the motor shaft.

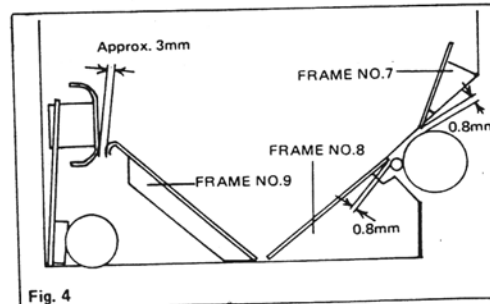

1-5. PINCH ROLLER PRESSURE

Plug in the power cord and turn switch on. Adjust the solenoid position so that the tension to separate the pinch roller from the motor shaft is 1.0-1.4kg, using a spring balance. See Fig.5.

CAUTION: Make sure that pinch roller surface is perfectly parallel with the motor shaft.

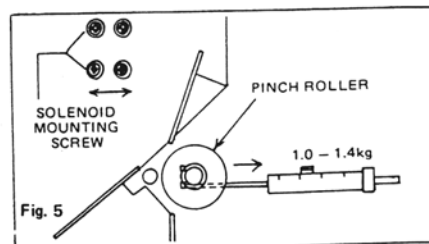

1-6. TAPE PACK HEIGHT (FINAL)

- a) Thread the tape and run it.
- b) Consulting Fig.6, visually adjust the head alignment. (This alignment must be made first, otherwise tape cannot run stably.)

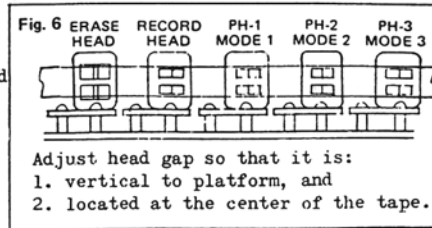

- c) For products without cutting on Leaf Spring;
Adjust Frame No.10 so that the tape passes right below the flange edge of the bearing roller.

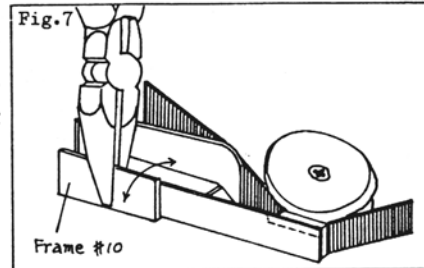

- d) For products with Spring around Height Adjust Screw:

Make sure that the tape travels with its lower edge 1 ± 0.2 mm above Frame No.8, measured at the pinch roller side.

The Frame No.8 height is adjusted by Height Adjusting Screw "A".

After adjustment of step 1-2, there would be no need of turning the screw so much. If it happens that due to adjustment of this step, the height of tape chassis largely deviates from 10.5mm, there might be another problem to be solved.

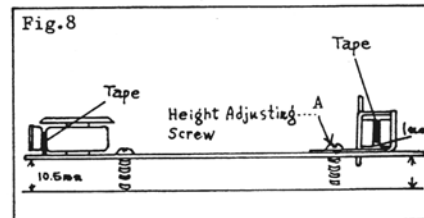

2. ELECTRICAL ADJUSTMENT

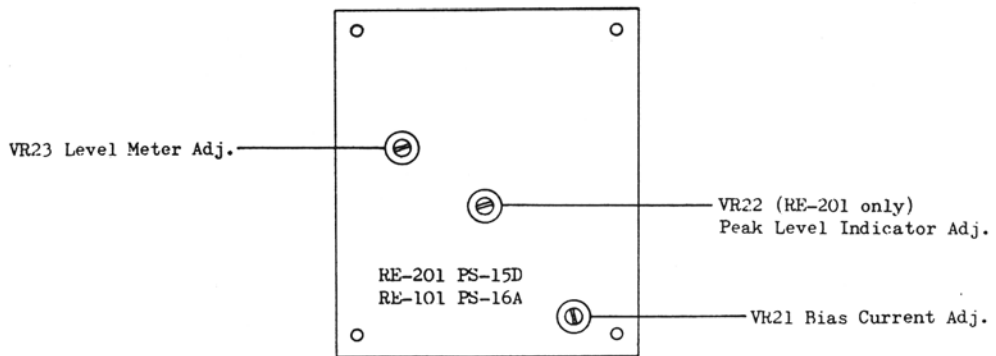
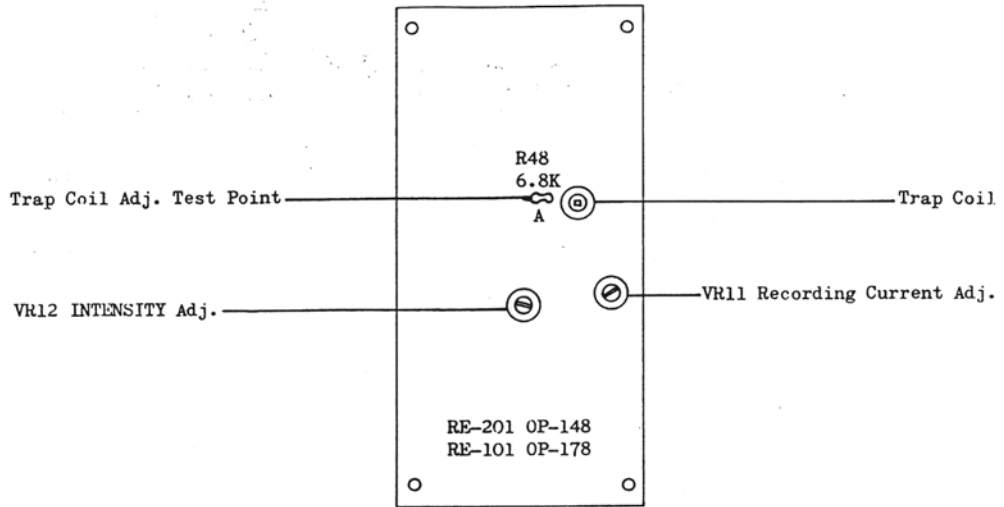

2-1. TRAP COIL

Adjust Trap Coil (L21) so that bias leakage at Point "A" (R48, 6.8Kohms) is below 2.5Vrms. If the voltage cannot be lowered than the level, replace C37 (470p) with a new one.

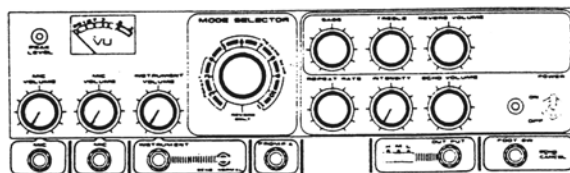

2-2. HEAD ALIGNMENT

Before attempting the following electrical adjustment, make sure that mechanical head alignment is perfected.

(a) Run the tape and adjust Record and Playback Heads with alignment screws so that their gaps are completely perpendicular to the edge of the running tape, and that all heads' gap-width dimensions are centered on the tape path.

(b) While monitoring an individual waveform on a scope, adjust alignment screws to obtain maximum output at high frequencies.

The ideal is for all playback heads' output to be equal in levels. Difference in the levels should be minimized by reducing the output of head with higher output. To reduce the output level, center off slightly the playback head's gap from the track.

When doing so, be careful not to cause ill affect on the high frequency response by tilting or azimuth error.

2-3. RECORDING BIAS/CURRENT

Feed sine wave signal, -50dB to input.

(a) Recording Bias

Adjust VR21 for maximum output.

(b) Recording Current

Adjust VR11 for -12dBm output.

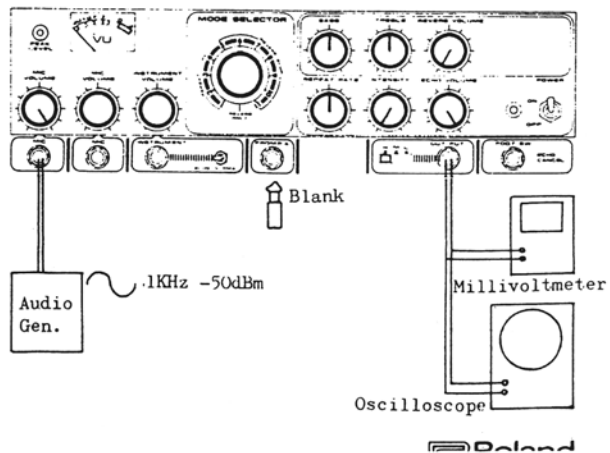
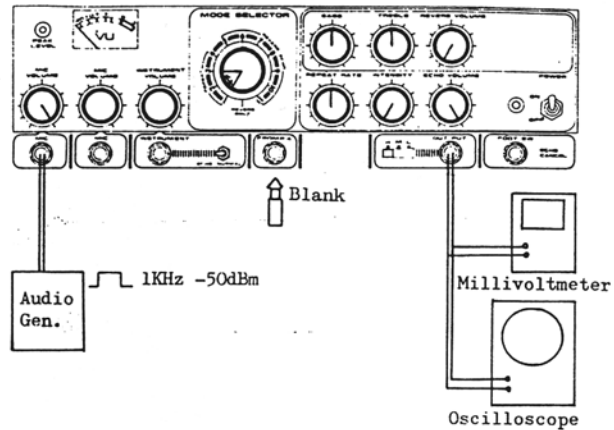

2-4. DIRECT OUTPUT CHECKING

Remove the Blank Plug from FROM PA jack. Turn Echo Volume fully counterclockwise. Make sure that direct signal output is $-15\text{dB} \pm 1\text{dBm}$.

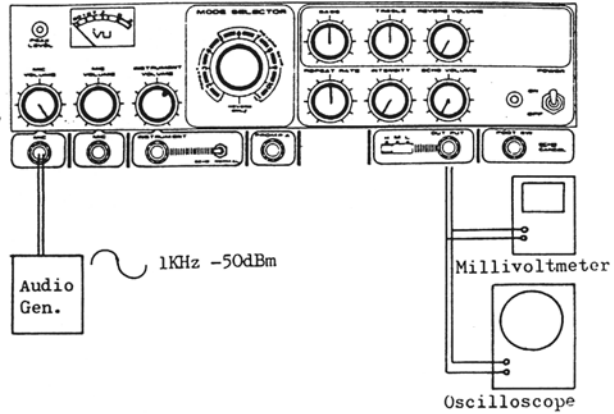

2-5. PEAK LEVEL/ LEVEL METER

a) PEAK LEVEL (RE-201 only)
Adjust VR22 so that LED lights dimly at -50dB input signal and goes off completely at -48dB input.

b) LEVEL METER
Adjust VR23 for 0dB reading on Level Meter at -50dB input.

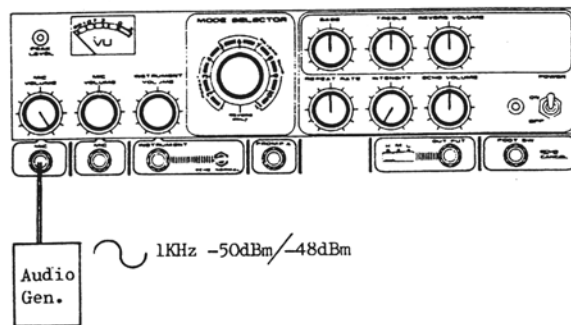

2-6. INSTRUMENT INPUT jack

Feed 1KHz , -24dBm sine wave to INSTRUMENT Input jack. Check to see that the outputs are as shown below.

SELECTOR	OUTPUT
ECHO	-15dBm
NORMAL	-12.5dBm

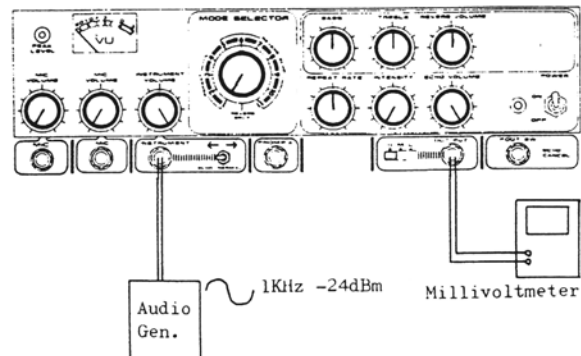

2-7. INTENSITY

Adjust VR12 so that multiple repetition of noises occurs with Intensity Control as shown.

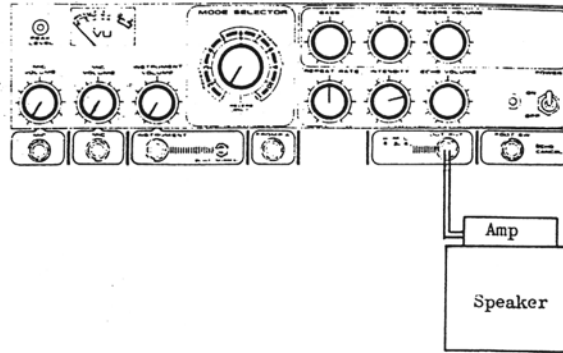

Other Reference Data

Bias Voltage 50 - 60Vrms across Erase Head.

Tape Speed 12cm - 40cm/sec (approx)

Tone Control: Treble... ± 10 dB at 5KHz

Bass ± 10 dB at 100Hz

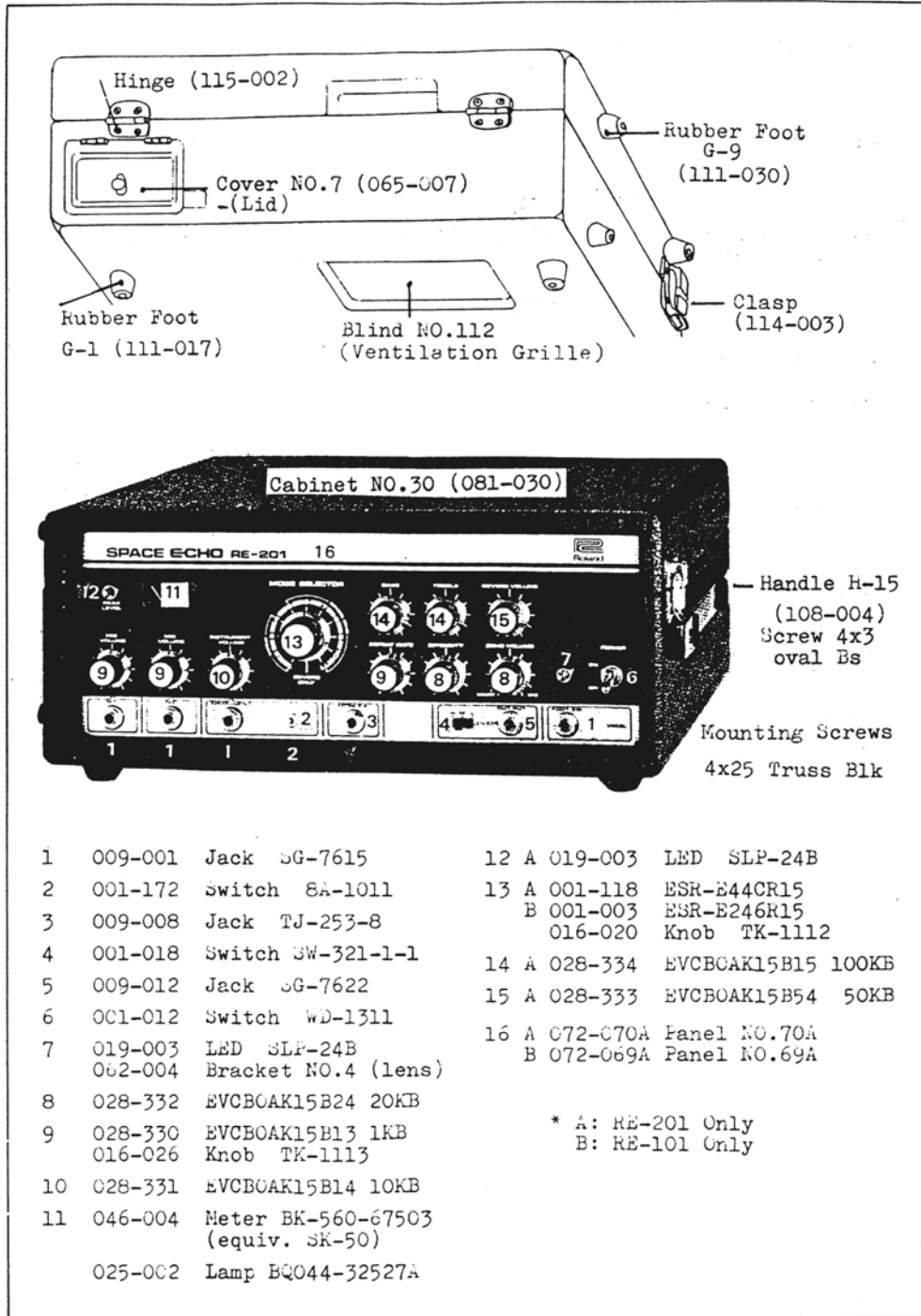

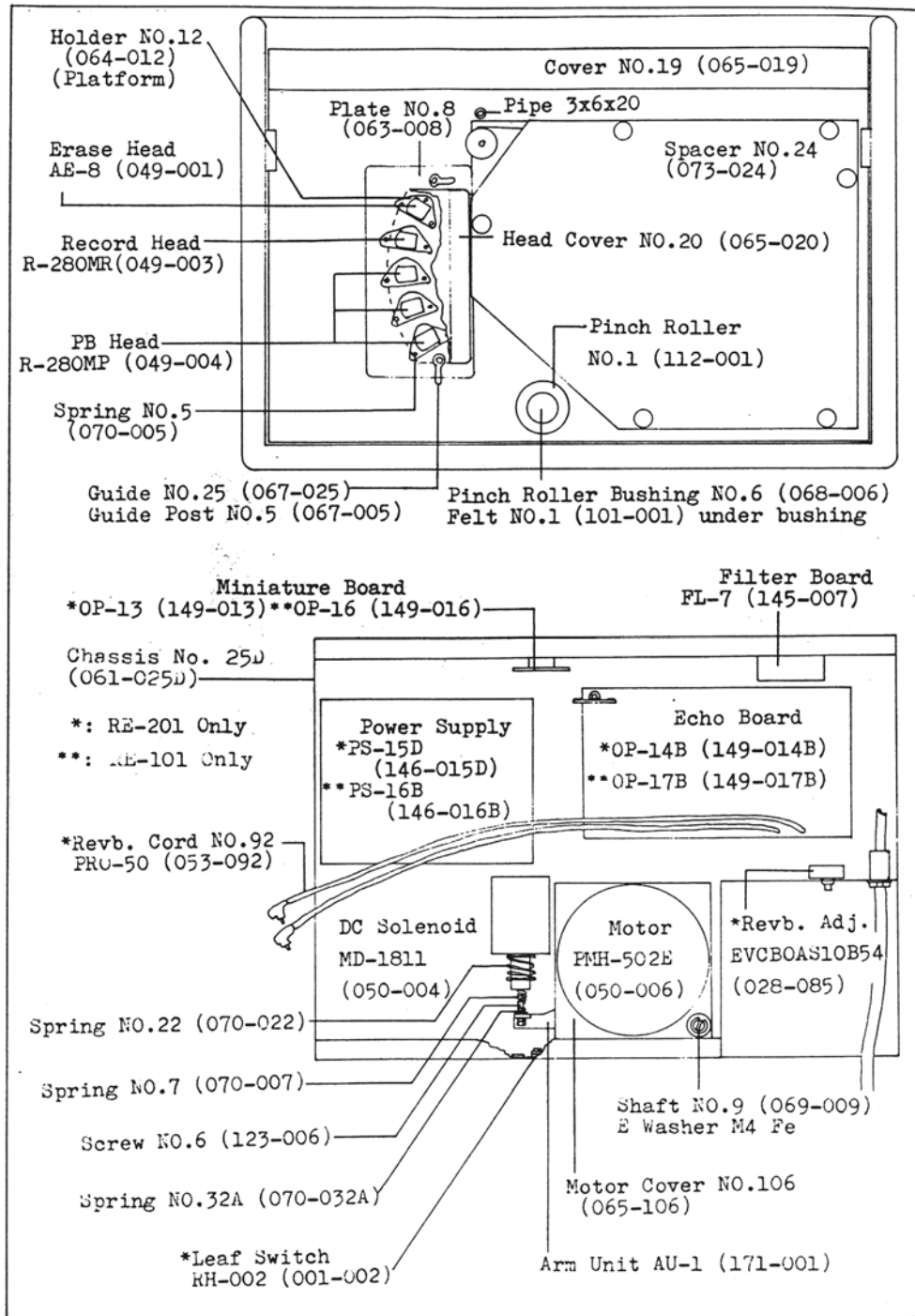

PART NO.	PART AND DESCRIPTION	PART NO.	PART AND DESCRIPTION
RE-101 Only		171-001	Arm Unit Assy AU-1
072-069A	Panel No.69A	069-009	Shaft No.9, AU-1 Mounting
001-003	Rotary Switch ESR-E246R15	050-004	DC Solenoid, Magnet & Plunger
	PCB Assy	070-007	Spring No.7, Plunger
149-017B	OP-17B Echo Board (052-098B)	070-022	Spring No.22, Solenoid
149-016	OP-16 Miniature Board (052-100)	070-032A	Spring No.32A
146-016B	PS-16B Power Supply Board (052-099E)	123-006	Screw No.6, Plunger Adj.
RE-201 Only		016-026	Knob TK-1113
072-070A	Panel No.70A	016-020	Knob TK-1112
001-118	Rotary Switch ESR-E44CR15	062-004	Bracket No.4, Lens, LED
028-333	EVCBOAK15B54 50KB Reverb Vol.	068-001	Pad No.1 (inside Bracket)
038-334	Potentiometer EVCBOAK15B15 100KB Bass Treble	121-007	Spring Nut No.7, M8p, Bracket No.4
028-085	Potentiometer EVCBOAS10B54 50KB Reverb Adj.		Switches
020-028	IC TA-7200P	001-012	WD-1311 Power
040-001	Reverb Unit Z-3F	001-102	8A-1011 Miniature Toggle
	PCB Assy	001-018	SW-321-1-1 Slide
149-014B	OP-14B Echo Board (052-098E)	009-001	Jack SG-7615
149-013	OP-13 Miniature Board (052-100)	009-008	Jack TJ-253-8, From PA
146-015D	PS-15D Power Supply Board (052-099E)	009-012	SG Jack SG-7622, Output
001-002	Leaf Switch RH-002	046-004	VU Meter BK-560-67503, Equiv. SK-50
RE-101 and RE-201 include the following.		025-002	Lamp BQ044 (14V 80mA)
081-030A	Cabinet (Upper & Lower)	022-094	Coil MC-126-2133B, OSC
108-104	Carrying Handle H-15	022-045	Coil MC-128 Trap
065-007	Cover No.7 (Lid Cord Compartment)	022-068AC	Power Transformer No.68AC, 100/117V
114-003	Clasp	022-067AD	Power Transformer No.67AD, 220/240V
115-002	Hinge	012-003	Fuse Holder TF-758, SEC.
111-017	Rubber Foot G-1 (Large)	012-018	Fuse Holder X-N1153, Prim. 220/240V
111-030	Rubber Foot G-9 (Small)	042-032	Terminal TT-501 D-1, 2p, 220/240V
065-112	Blind No.112, Ventilation Grille	047-025	Line Cord Strain Relief EA-5
131-023	Vinyl Cover No.23		Transistors
130-048	Carton No.48	017-251	2SD234-0
061-025D	Chassis No.25D, Main	017-008	2SC828-R
065-019	Cover No.19, Front	017-003	2SC1000-GR
073-024	Spacer No.24, Side	017-072	2SD571-L
064-012	Holder H-12 (Platform)	017-024	2SA733-P
063-008	Plate No.8, Head Mounting		Diodes
065-020	Head Cover No.20	018-035	05Z-5.6 (5.6V 1/2W), Zener
067-025	Guide No.25	018-014	1S-2473
067-005	Guide Post No.5	018-018	1N-4003
049-003	Record Head R-280MR	018-062	MI-152
049-004	Playback Head R-280MP	018-063	MI-152R
049-001	Erase Head AE-28	019-003	SLP-24B LED
112-001	Pinch Roller	018-036	SMT-100 1K ohm at 25° Centigrade, Thermistor
068-006	Cover No.6, Pinch Roller		Fuse
101-001	Felt No.1, Under Cover No.6	008-023	SGA-0.25A, Sec.
050-006	Motor PHM-502E-B02	008-028	SGA-2A, Sec.
120-037	Nut No.37, Motor Mounting	008-041	MGP-1A, Pigtail, Pri.
065-106	Cover No.106, Motor	008-060	CEE 250mAT, Sec.
		008-069	CEE 1.6AT, Sec.
		008-066	CEE 1AT, Sec.
		145-007	FL-7 PCB Assy, Filter Board (052-226)

PART NO.	PART AND DESCRIPTION
028-330	Potentiometer EVCBOAK15B13 1KB, Mic, Re.rate, Inte
028-332	EVCBOAK15B24 20KB Echo Vol.
028-331	EVCBOAK15B14 10KB Inst.
028-004	EVTR4AAB14 10KB Trimmer.
028-005	EVTR4AAB24 20KB
028-006	EVTR4AAB54 50KB
	Optional
057-004	Cleaner Set.
057-006	Tape RT-1L (4.5m)
053-013	Connection Cord LI-10

PARTS ORDERING INFORMATION

Name of part number of some of the parts is changed from those printed on previously issued parts list. When ordering replacement parts, be sure to follow the description on the present issue.

When ordering parts, be sure to include the following information:

1. Model and Serial Number
2. Part Number
3. A Description of the Part

This parts list includes all standard stock replacement parts. No attempt has been made to include every nut, bolt and screw. If the necessity for a non-listed part arises, please write describing the parts location and function as well as model and serial number of the unit.
