

PS CIRCUIT DIAGRAM

EMX5016CF

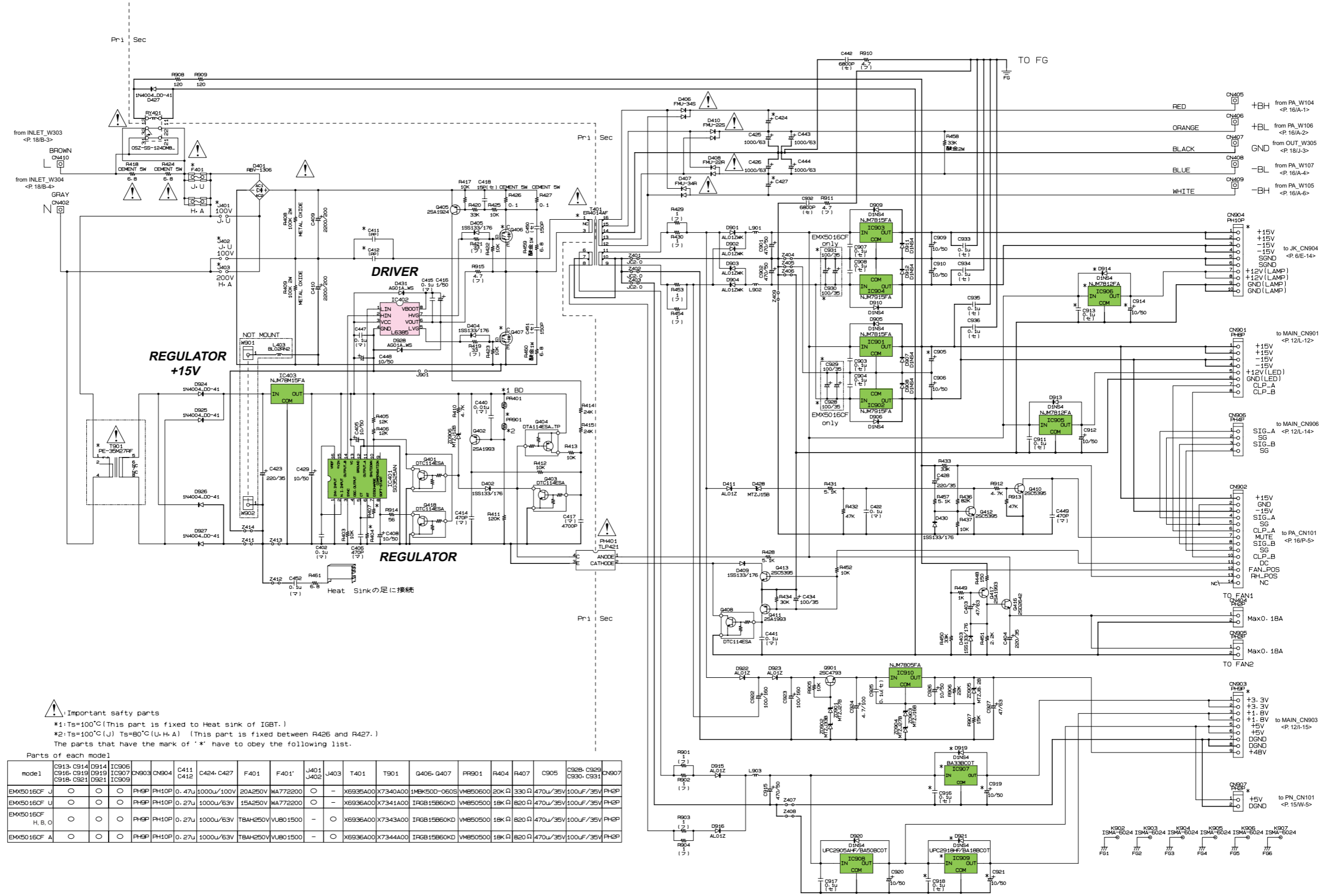

⚠ Important safety parts
 *1: Ts=100°C (This part is fixed to Heat sink of IGBT.)
 *2: Ts=100°C (J) Ts=80°C (U, H, A) (This part is fixed between R426 and R427.)
 The parts that have the mark of '*' have to obey the following list.

Parts of each model

model	C913, C914, C916, C919, C918, C921	D914, D919, D921	IC906, IC907, IC909	CN903, CN904	C411, C412	C424, C427	F401, F401'	J401, J402	J403	T401	T901	G406, G407	FR901	R404, R407	C905	C928, C929, C930, C931	CN907
EMX5016CF J	○	○	○	PH-EP, PH10P	0.47u, 1000u/100V	20A250V, WA772200	○	-	X6935A00	X7340A00	1M6K50D-0605	VN850600	20KΩ, 330Ω	470u/35V, 100uF/35V	PH-EP		
EMX5016CF U	○	○	○	PH-EP, PH10P	0.27u, 1000u/63V	15A250V, WA772200	○	-	X6936A00	X7341A00	IRGB15B60KD	VN850500	18KΩ, 820Ω	470u/35V, 100uF/35V	PH-EP		
EMX5016CF H, B, O	○	○	○	PH-EP, PH10P	0.27u, 1000u/63V	T8A250V, VU801500	-	○	X6936A00	X7343A00	IRGB15B60KD	VN850500	18KΩ, 820Ω	470u/35V, 100uF/35V	PH-EP		
EMX5016CF A	○	○	○	PH-EP, PH10P	0.27u, 1000u/63V	T8A250V, VU801500	-	○	X6936A00	X7344A00	IRGB15B60KD	VN850500	18KΩ, 820Ω	470u/35V, 100uF/35V	PH-EP		

Note : See parts list for details of circuit board component parts.
 1 2 3 4 5 6 7 8 9 10 11 12

- ⊘ dz γ Ceramic Capacitor
- γ # Electrolytic Capacitor
- ⊘ dz γ Milar Capacitor
- ⊘ dz γ Polypropylene Capacitor
- ⊘ dz γ Flame Proof C. Resistor
- ⊘ γ .FUBMOxide Film Resistor
- ⊘ dz γ CeramYttrata?dz
- ⊘ dz γ Xafitota?dz
- ⊘ dz γ P4?itota?dz
- ⊘ dz γ 262ifitota?dz
- ⊘ dz γ aIuX?Ot †
- ⊘ dz γ Iu?o:U †dz

28CC1-2000010921 ⚠