



# ***SERVICE MANUAL***

## ***xm200 / xm200t***

WEB ACCESS: <http://www.yorkville.com>

### **WORLD HEADQUARTERS CANADA**

**Yorkville Sound**  
550 Granite Court  
Pickering, Ontario  
L1W-3Y8 CANADA

Voice: (905) 837-8481  
Fax: (905) 837-8746

### **U.S.A.**

**Yorkville Sound Inc.**  
4625 Witmer Industrial Estate  
Niagara Falls, New York  
14305 USA

Voice: (716) 297-2920  
Fax: (716) 297-3689



**Quality and Innovation Since 1963**  
Printed in Canada

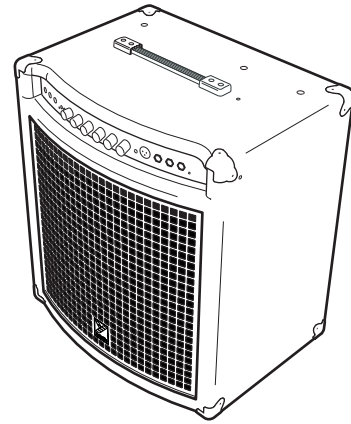

## IMPORTANT SAFETY INSTRUCTIONS



**INSTRUCTIONS PERTAINING TO A RISK OF FIRE, ELECTRIC SHOCK, OR INJURY TO PERSONS.**

**INSTRUCTIONS RELATIVES AU RISQUE DE FEU, CHOC ÉLECTRIQUE, OU BLESSURES AUX PERSONNES.**

### **CAUTION:**

**TO REDUCE THE RISK OF ELECTRIC SHOCK, DO NOT REMOVE COVER (OR BACK). NO USER SERVICEABLE PARTS INSIDE.**

**REFER SERVICING TO QUALIFIED SERVICE PERSONNEL.**

### **AVIS:**

**AFIN DE REDUIRE LES RISQUE DE CHOC ELECTRIQUE, N'ENLEVEZ PAS LE COUVERT (OU LE PANNEAU ARRIERE). NE CONTIENT AUCUNE PIECE REPARABLE PAR L'UTILISATEUR.**

**CONSULTEZ UN TECHNICIEN QUALIFIE POUR L'ENTRETIEN.**

### **Read Instructions:**

The *Owner's Manual* should be read and understood before operation of your unit. Please, save these instructions for future reference.

### **Packaging:**

Keep the box and packaging materials, in case the unit needs to be returned for service.

### **Warning:**

When using electric products, basic precautions should always be followed, including the following:

#### **Power Sources:**

Your unit should be connected to a power source only of the voltage specified in the owners manual or as marked on the unit. This unit has a polarized plug. Do not use with an extension cord or receptacle unless the plug can be fully inserted. Precautions should be taken so that the grounding scheme on the unit is not defeated.

#### **Hazards:**

Do not place this product on an unstable cart, stand, tripod, bracket or table. The product may fall, causing serious personal injury and serious damage to the product. Use only with cart, stand, tripod, bracket, or table recommended by the manufacturer or sold with the product. Follow the manufacturer's instructions when installing the product and use mounting accessories recommended by the manufacturer.

The apparatus should not be exposed to dripping or splashing water; no objects filled with liquids should be placed on the apparatus.

Terminals marked with the "lightning bolt" are hazardous live; the external wiring connected to these terminals require installation by an instructed person or the use of ready made leads or cords.

No naked flame sources, such as lighted candles, should be placed on the apparatus.

#### **Power Cord:**

The AC supply cord should be routed so that it is unlikely that it will be damaged. If the AC supply cord is damaged **DO NOT OPERATE THE UNIT.**

#### **Service:**

The unit should be serviced only by qualified service personnel.

### **Veillez lire le manuel:**

Il contient des informations qui devraient étre comprises avant l'opération de votre appareil. Conservez S.V.P. ces instructions pour consultations ultérieures

### **Emballage:**

Conservez la boîte au cas où l'appareil devait étre retourner pour réparation.

### **Attention:**

Lors de l'utilisation de produits électrique, assurez-vous d'adhérer à des précautions de bases incluant celle qui suivent:

#### **Alimentation:**

L'appareil ne doit étre branché qu'à une source d'alimentation correspondant au voltage spécifié dans le manuel ou tel qu'indiqué sur l'appareil. Cet appareil est équipé d'une prise d'alimentation polarisée. Ne pas utiliser cet appareil avec un cordon de raccordement à moins qu'il soit possible d'insérer complètement les trois lames. Des précautions doivent étre prises afin d'éviter que le système de mise à la terre de l'appareil ne soit désengagé.

#### **Risque:**

Ne pas placer cet appareil sur un chariot, un support, un trépied ou une table instables. L'appareil pourrait tomber et blesser quelqu'un ou subir des dommages importants. Utiliser seulement un chariot, un support, un trépied ou une table recommandés par le fabricant ou vendus avec le produit. Suivre les instructions du fabricant pour installer l'appareil et utiliser les accessoires recommandés par le fabricant.

Il convient de ne pas placer sur l'appareil de sources de flammes nues, telles que des bougies allumées.

L'appareil ne doit pas étre exposé à des égouttements d'eau ou des éclaboussures et qu'aucun objet rempli de liquide tel que des vases ne doit étre placé sur l'appareil.

Les dispositifs marqués d'une symbole "d'éclair" sont des parties dangereuses au toucher et que les câblages extérieurs connectés à ces dispositifs de connection extérieure doivent étre effectués par un opérateur formé ou en utilisant des cordons déjà préparés.

#### **Cordon d'alimentation:**

Évitez d'endommager le cordon d'alimentation. **N'UTILISEZ PAS L'APPAREIL** si le cordon d'alimentation est endommagé.

#### **Service:**

Consultez un technicien qualifié pour l'entretien de votre appareil.

**XM20001.xls Parts List 10/7/2002**

YS #	Description	Qty.	YS #	Description	Qty.	YS #	Description	Qty.
6405	RED 3MM LED 1V7 5MA BRT	2	3426	8' 3/16 SJT AC LINE CORD REMOVBCSA	1	8866	#6 NYLON SPACER OD.250XID.140X.187	2
6407	YEL 3MM LED 1V8 5MA	1	8701	4-40 KEPS NUT ZINC	2	7347	15" 4R 200WPGM SPEAKER BASS	1
6825	1N4148 75V 0A45 DIODE T&R	7	8800	6-32 KEPS NUT ZINC	9	8818	3/4 OD X 3/8 ID X .080 THICK WASHER	1
6438	1N4004 400V 1A0 DIODE T&R	4	8845	10-32 PEMNUT SS-032-2-Z1	2	8473	#10 BLACK CUPWASHER SWF-10BK	1
6434	6A2 200V 6A0 DIODE	4	8898	1/4-20 CAGE NUT C7998142027	3	3425	DPDT PUSH SW PCMT BREAK B4 MAKE	3
6733	BAT85 30V 0A2 DIODE SCHTKYT&R	10	8797	5/16-18 KEPS NUT JS500	1	3698	SPST ROKR SW QUIK 180" AC PWR BL/BL	1
6822	1N4745A 16V0 1W0 ZENER 5% T&R	4	3814	TO3 THERMAL CONDUCTOR ELASTOMER	2	6554	BLUE 3MM LED 3V9 20MA TLHB440VISHAY	1
6463	1N5251BRL 22V0 0W5 ZENER 5% T&R	1	3823	TO-220 THERMO PAD SMALL HOLE	2	8768	5/16-18X2 1/2 CARRIAGE BOLT ZINC	1
5101	BC550C TO92 NPN TRAN T&R TB	3	4599	22AWG SOLID SC WIR T&R JMP	56	3409	THERMO SW N/CLOSED OP/184F CL/144F	1
5102	BC560C TO92 PNP TRAN T&R TB	3	5299	24AWG SOLID SC WIR RAD JMP	2	CH1396	125VAC DOUBLE INSULATION T'RD	1
5119	2N5638 TO92 NCH JFET T&R TC	1	4719	5.0W 0R18 5% BLK RES	2			
5122	J109 TO92 NCH JFET T&R TC	1	4866	1/4W 4R7 5% T&R RES	2			
6787	BD237 TO126 NPN TRAN TG	1	4675	1/2W 10R 5% T&R RES	1			
6788	BD238 TO126 PNP TRAN TG	1	4750	5.0W 10R 5% BLK RES	1			
6909	MJ21196 TO3 NPN TRAN TH	1	4812	1/4W 18R 5% T&R RES	1			
6910	MJ21195 TO3 PNP TRAN TH	1	4618	1/2W 22R 5% T&R RES	2			
6882	TL072CP IC FET DUAL OP AMP	6	4817	1/4W 47R 5% T&R RES	2			
6889	TL074CN IC QUAD O/A T.I ONLY	1	4811	1/4W 68R 5% T&R RES	1			
6860	VTL5C8 OPTO-COUPLER	1	4912	1/4W 75R 5% T&R RES	1			
5404	_27P 100V 10%CAP T&R BEAD NPO	1	4852	1/4W 100R 5% T&R RES	1			
5410	100P 100V 10%CAP T&R BEAD NPO	4	4659	1/2W 150R 5% T&R RES	6			
5420	680P 50V 10%CAP T&R BEAD NPO	3	4859	1/4W 150R 5% T&R RES	2			
5423	_1N2 50V 10%CAP T&R BEAD X7R	1	4857	1/4W 220R 5% T&R RES	1			
5425	_1N8 50V 10%CAP T&R BEAD X7R	2	4770	1/4W 249R 1% T&R RES	4			
5428	_3N3 50V 10%CAP T&R BEAD Y5R	3	4867	1/4W 270R 5% T&R RES	1			
6451	_4N7 250V 20%CAP BLK 'Y' 10MM AC	1	4736	5.0W 390R 5% BLK RES	1			
5433	_5N6 50V 10%CAP T&R BEAD X7R	1	4872	1/4W 390R 5% T&R RES	1			
5300	_10N 50V 10%CAP T&R BEAD X7R	1	4821	1/4W 470R 5% T&R RES	1			
5301	_12N 50V 10%CAP T&R BEAD X7R	1	4873	1/4W 680R 5% T&R RES	1			
5210	_22N 100V 10%CAP T&R RAD .2"FLM	1	4726	5.0W 1K 5% BLK RES	2			
6435	_22N 275V 20%CAP BLK 'X2' 15MM AC	2	4823	1/4W 1K 5% T&R RES	6			
5306	_33N 50V 10%CAP T&R BEAD X7R	2	4981	1/4W 1K 5%MINI T&R RES	1			
5308	_47N 50V 10%CAP T&R BEAD X7R	2	4802	1/4W 1K21 1% T&R RES	1			
5310	_68N 50V 10%CAP T&R BEAD X7R	2	4824	1/4W 1K5 5% T&R RES	1			
5312	_82N 50V 10%CAP T&R BEAD X7R	1	4808	1/4W 2K 5% T&R RES	1			
5212	100N 63V 5%CAP T&R RAD .2"FLM	12	4919	1/4W 2K05 1%-NO SUBS- T&R RES	1			
5231	220N 63V 10%CAP T&R RAD .2"FLM	1	4847	1/4W 2K2 5% T&R RES	3			
5318	220N 50V 10%CAP T&R BEAD X7R	2	4805	1/4W 2K87 1% T&R RES	1			
5234	470N 63V 10%CAP T&R RAD .2"FLM	1	4626	1/2W 3K3 5% T&R RES	10			
5322	470N 50V 10%CAP T&R BEAD Z5U	1	4826	1/4W 3K3 5% T&R RES	2			
5255	_1U 63V 20%CAP T&R RAD .2"EL	1	4774	1/4W 4K12 1% T&R RES	3			
5256	_1U 63V 5%CAP T&R RAD .2"FLM	1	4627	1/2W 4K7 5% T&R RES	1			
5257	_2U2 63V 20%CAP T&R RAD .2"EL	1	4681	1.0W 4K7 5% T&R RES	2			
5942	_3U3 100V 20%CAP BLK RAD POLY FLM	1	4827	1/4W 4K7 5% T&R RES	7			
5282	_10U 16V 20%CAP T&R 5X7MM .2"NP	3	4639	1/4W 4K99 1% T&R RES	2			
5945	_10U 63V 20%CAP T&R RAD .2"EL	1	4862	1/4W 5K6 5% T&R RES	1			
5961	_33U 16V 20%CAP T&R RAD .2"NP	1	4887	1/4W 7K5 5% T&R RES	1			
5621	470U 63V 20%CAP BLK 12X25MM EL	4	4800	1/4W 10K0 1% T&R RES	13			
5887	2200U 50V 20%CAP BLK 18X27MM EL	2	4829	1/4W 10K 5% T&R RES	3			
4417	_10K 5B LIN 9MM HORIZONTAL P28	1	4773	1/4W 12K1 1% T&R RES	1			
4418	_10K 5C R/A 9MM HORIZONTAL P28	1	4885	1/4W 20K 5% T&R RES	3			
4420	_50K B LIN 9MM HORIZONTAL P28	4	4832	1/4W 22K 5% T&R RES	2			
4529	470R TRIM POT	1	4902	1/4W 24K 5% T&R RES	2			
713	25 X 20 X 50 2 MIL PLASTIC BAG	1	4840	1/4W 33K 5% T&R RES	1			
3819	_5UH COIL 18AWG R000 AIR CORE	1	4834	1/4W 47K 5% T&R RES	3			
8504	CORNER, 2 LEGS NOTCHED LIP NICKEL	8	4838	1/4W 100K 5% T&R RES	3			
8545	RECESSED RUBBER BUMPER WITH WASHER	4	4874	1/4W 560K 5% T&R RES	4			
3463	CLIP 110X020 18-22AWG DISCO/INSL	2	4844	1/4W 1M 5% T&R RES	2			
3478	CLIP 205/187X032 18-22AWG DISCO/INS	2	8741	4-40 X 1/2 PAN PH MS JS500	2			
3489	CLIP 250X032 18-22AWG DISCO/INSL	10	8842	#4 X 5/16 PAN QUAD TYPE A JS500 BLK	2			
3491	CLIP 205/187X020 18-22AWG DISCO/INS	4	8832	6-32 X 1/4 PAN PH TAPTITE JS500	3			
3682	250 MALE PCB TAB REEL	11	8801	6-32 X 3/8 PAN PH TAPTITE JS500	5			
3498	1/4" JCK PCB MT HORZ	2	8829	6-32 X 3/8 FLAT PH TAPTITE BO#4 HEA	4			
3523	1/4" JCK PCB MT HORZ GOLD T__	4	8835	6-32 X 1/2 PAN QUAD MS TIN PLATED	4			
3527	1/4" JCK PCB MT HORZ GOLD __S	1	8828	6-32 X 3/4 PAN PH TAPTITE JS500	2			
3923	XLR MALE PCB MT HORZ MTHOLE-V SNAP	1	8811	#6 X 1 1/4 FLAT RBTSN WOOD CLEAR ZN	8			
3451	EYELET SMALL 0.089 OD PLATED	13	8878	#6 X 2" PAN PHIL TYPE A JS500 BLACK	4			
3414	INTERNATIONAL PC MOUNT FUSEHOLDER	2	8803	8-32 X 3/8 PAN QUAD TAPTITE JS500	9			
2407	2.5 AMP SLO-BLO .25X1.25 FUSE	1	8785	#8 X 3/4 OVAL PH TYPE A BLACK OXIDE	6			
7417	8R 30W TWEETER PIEZO TLC 1	1	8749	10-32 X 1/2 QDX PH TAPTITE JS500	1			
3501	B52200F006 COMP WASH #4 SMALL	2	8750	#10 X 1/2 PAN PH TYPE A ZINC	16			
3804	SNAP ON 1.5" INSULATING BUSHING	1	8756	#10 X 3/4 PAN PH TYPE A BLACK OXIDE	4			
8609	VINYL CAP 0.250" X 1/2" BLK.	2	8781	#10 X 7/8 FLAT PHIL TYPE A JS500BLK	2			
3645	AC SOCKET RECEPTACLE WITH 0.250 TAB	1	8843	10-32 X 1 1/8 FLAT PH MS JS500	2			
3795	#8 GROUND LUG ZIERICK 505-169	3	8786	10-32 X 1 1/4 PAN QD MS JS500 BLACK	4			
3803	NYLON SECUR-A-TACH MINI PLASTIC TIE	1	8751	10-32 X 2 PAN PH MS JS500	2			
3810	4" NYLON CABLE TIE	7	8777	#14 X 1FLAT PH TYPE A JS500 M6 HEAD	4			
3827	SQUARE BUMPER BUTTON BLACK	1	8847	1/4-20 X 1 1/4 FLAT PH MS JS500	3			
8399	BASSMASTER KNOB, NICKEL/CHROME	6	8905	YORKVILLE PRODUCT SCHEMATIC	1			
8636	BUTTON KNOB FLAT BLACK	3	8663	11/64 NYLON SPACER (MICRO PLASTIC)	4			

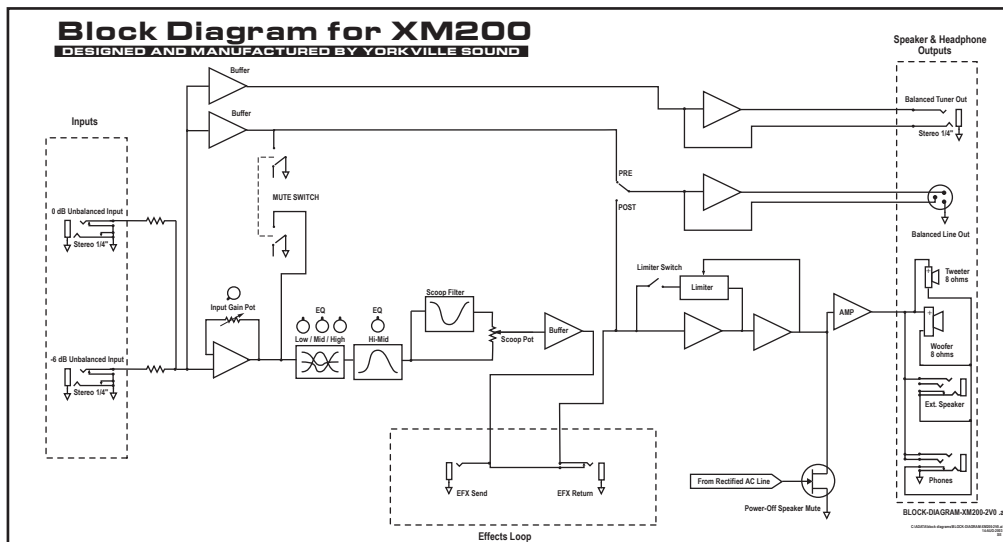

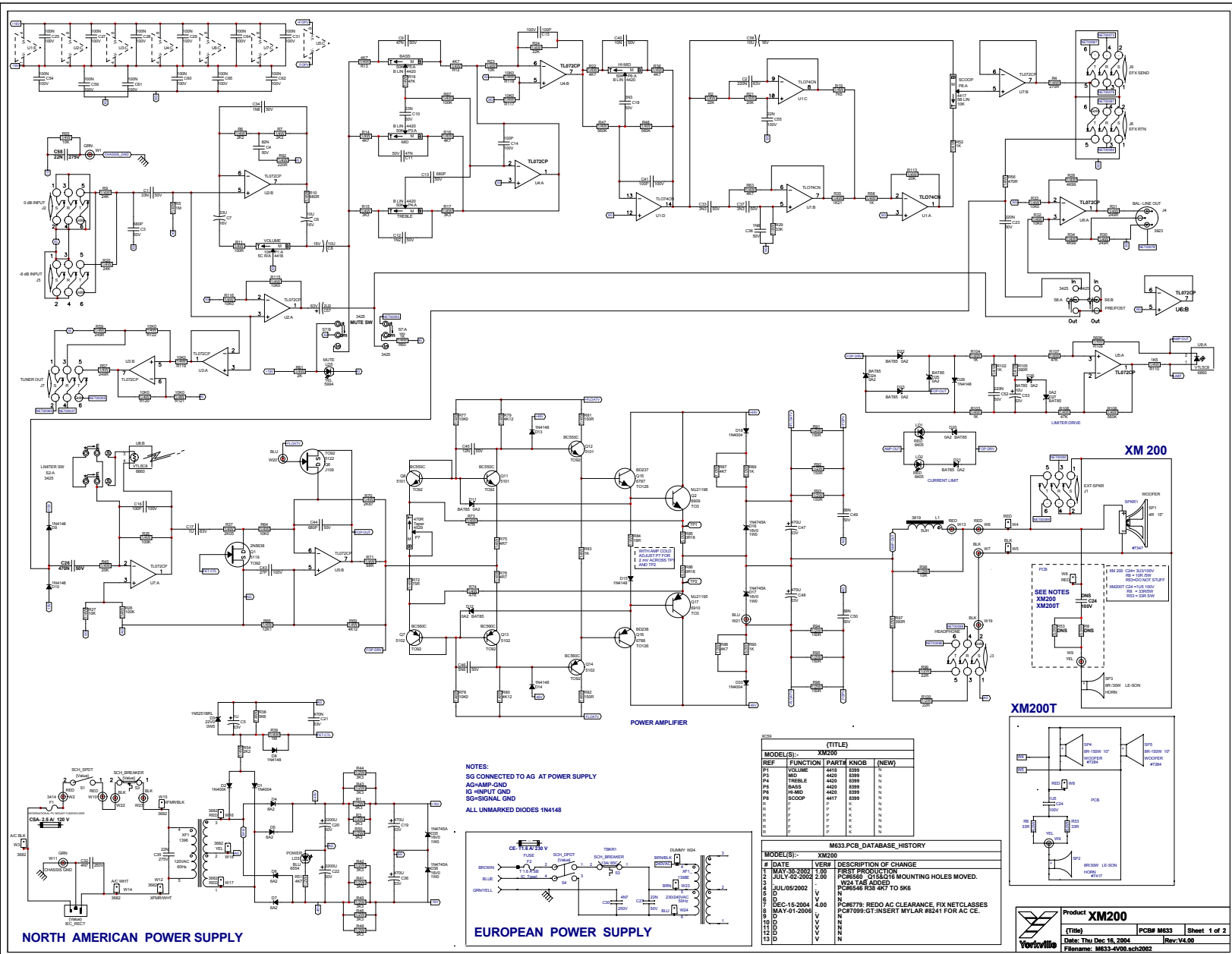

NOTES:  
 SG CONNECTED TO AG AT POWER SUPPLY  
 AD=ANP-GND  
 IG=INPUT GND  
 SO=SIGNAL GND  
 ALL UNMARKED DIODES 1N4148

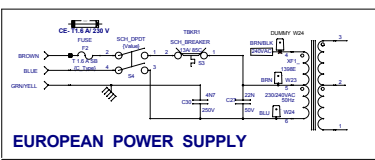

REF	FUNCTION	PART#	QTY	NEW
P1	VOLUME	4212	1	N
P3	MID	4422	1	N
P4	TREBLE	4422	1	N
P5	BASS	4422	1	N
P6	M-MID	4422	1	N
P8	SCOOP	4417	1	N
R1	P	P	N	N
R2	P	P	N	N
R3	P	P	N	N
R4	P	P	N	N
R5	P	P	N	N
R6	P	P	N	N
R7	P	P	N	N
R8	P	P	N	N
R9	P	P	N	N
R10	P	P	N	N
R11	P	P	N	N
R12	P	P	N	N
R13	P	P	N	N
R14	P	P	N	N
R15	P	P	N	N
R16	P	P	N	N
R17	P	P	N	N
R18	P	P	N	N
R19	P	P	N	N
R20	P	P	N	N
R21	P	P	N	N
R22	P	P	N	N
R23	P	P	N	N
R24	P	P	N	N
R25	P	P	N	N
R26	P	P	N	N
R27	P	P	N	N
R28	P	P	N	N
R29	P	P	N	N
R30	P	P	N	N
R31	P	P	N	N
R32	P	P	N	N
R33	P	P	N	N
R34	P	P	N	N
R35	P	P	N	N
R36	P	P	N	N
R37	P	P	N	N
R38	P	P	N	N
R39	P	P	N	N
R40	P	P	N	N
R41	P	P	N	N
R42	P	P	N	N
R43	P	P	N	N
R44	P	P	N	N
R45	P	P	N	N
R46	P	P	N	N
R47	P	P	N	N
R48	P	P	N	N
R49	P	P	N	N
R50	P	P	N	N
R51	P	P	N	N
R52	P	P	N	N
R53	P	P	N	N
R54	P	P	N	N
R55	P	P	N	N
R56	P	P	N	N
R57	P	P	N	N
R58	P	P	N	N
R59	P	P	N	N
R60	P	P	N	N
R61	P	P	N	N
R62	P	P	N	N
R63	P	P	N	N
R64	P	P	N	N
R65	P	P	N	N
R66	P	P	N	N
R67	P	P	N	N
R68	P	P	N	N
R69	P	P	N	N
R70	P	P	N	N
R71	P	P	N	N
R72	P	P	N	N
R73	P	P	N	N
R74	P	P	N	N
R75	P	P	N	N
R76	P	P	N	N
R77	P	P	N	N
R78	P	P	N	N
R79	P	P	N	N
R80	P	P	N	N
R81	P	P	N	N
R82	P	P	N	N
R83	P	P	N	N
R84	P	P	N	N
R85	P	P	N	N
R86	P	P	N	N
R87	P	P	N	N
R88	P	P	N	N
R89	P	P	N	N
R90	P	P	N	N
R91	P	P	N	N
R92	P	P	N	N
R93	P	P	N	N
R94	P	P	N	N
R95	P	P	N	N
R96	P	P	N	N
R97	P	P	N	N
R98	P	P	N	N
R99	P	P	N	N
R100	P	P	N	N

#	DATE	VER#	DESCRIPTION OF CHANGE
1	MAY-30-2002	1.00	FIRST PRODUCTION
2	JULY-02-2002	2.00	PCB#560 CH3&D16 MOUNTING HOLES MOVED.
3	JULY-06-2002	V	W3 TAP ADDED
4	DEC-15-2004	V	PCB#779: REDO AC CLEARANCE, FIX NETCLASSES
5	MAY-01-2006	V	PCB#7999-ST:INSERT MYLAR #8241 FOR AC CE.
6		V	
7		V	
8		V	
9		V	
10		V	
11		V	
12		V	

**PRODUCTION NOTES**

- 1 ADD THERMAL JOINT COMPOUND(GOOP) BETWEEN Q8 AND Q11; Q7 AND Q13. COVER WITH VINYL CAP (8509) AND RTV.
- 2 FOR XM 200 STUFF R8=10R/5W  
C24= 3U3/100V  
DO NOT STUFF R53
- 3 FOR XM 200T STUFF R8=33R/5W  
R53=33R/5W  
C24=1U5/100V
- 4 CE VERSIONS: RTV PIECE OF #8241 MYLAR TO CHASSIS UNDER AC SECTION OF PCB BOARD (I.E. UNDER F1,C35,C32,W24,W14)

**FUSE**

N/A 2.5 A / 120 V (2407)  
CE 1.6 A / 230 V (2473)

**N/A**

W1 = GREEN 4.5"  
W6 AND W13 = RED 19"  
W7 AND W19 = BLACK 19"  
W9 = YELLOW 12"  
W10 = RED 9"  
W11 = GREEN 4.5"  
W20 AND W21 = BLUE 9"  
W22 = BLACK 6"  
W23 = BLACK 6"  
W2 = RED DIN'S 9"  
W10 = RED DIN'S 9"  
W22 = BLACK DIN'S 6"  
W23 = BLACK DIN'S 6"

**CE**

W2 = RED DIN'S 9"  
W10 = RED DIN'S 9"  
W22 = BLACK DIN'S 6"  
W23 = BLACK DIN'S 6"

M633.PCB\_DATABASE\_HISTORY

MODEL(S):-	XM200	DATE	VER#	DESCRIPTION OF CHANGE
		MAY-30-2002	1.00	FIRST PRODUCTION
		JULY-02-2002	V2.00	PC#6590: Q15 & Q16 MOUNTING HOLES MOVED. W24 TAB ADDED.
		JUL/05/2002	3.00	PC#6546 R53 MTD TO SK6
		JAN/15/2003	3.01	PC#6584 YEL LED #6407 TO #5994
		16-SEP-2003	4.00	Modified text, production notes
		DEC-15-2004	4.00	PC#6773: RELO AC CLEARANCE, FIX NETCLASSES, ADD TESTNODES
		MAY-01-2006	V	PC#7059:GT:INSERT MYLAR #8241 FOR AC CE.
			V	
			N	
			N	
			N	
			N	
			N	
			N	
			N	

M633 POTS LIST

MODEL(S):-	XM200	REF	FUNCTION	PART#	KNOB	(NEW)
		F1	VOLUME	4415	8399	N
		F4	MD	4420	8399	N
		F5	TREBLE	4420	8399	N
		F6	BASS	4420	8399	N
		F8	HAND	4420	8399	N
		F9	SCOOP	4417	8399	N
		R1	P	P	K	N
		R2	P	P	K	N
		R3	P	P	K	N
		R4	P	P	K	N
		R5	P	P	K	N
		R6	P	P	K	N
		R7	P	P	K	N
		R8	P	P	K	N

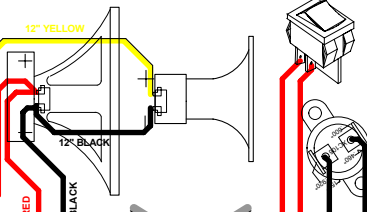
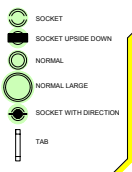

BlankSize - 18150x8775

Pcb Mech M633V4.00  
Top Assy M633V4.00

