

NOTE: TEST POINT CONDITIONS

LINE: 120 Vrms. SPEAKER LOAD: 8 OHM RESISTANCE  
 REVERB SEND LOAD: 150 OHM RESISTANCE  
 INPUT : 28mVrms @ 500HZ  
 VOLTAGES: ALL DC VOLTAGES MEASURED WITH  
 " NO SIGNAL INPUT"  
 SETTINGS: GAIN & EQ @ '5', REVERB @ '0',  
 LEVELS @ '10'. PRESENCE & BOOST = 'OFF'

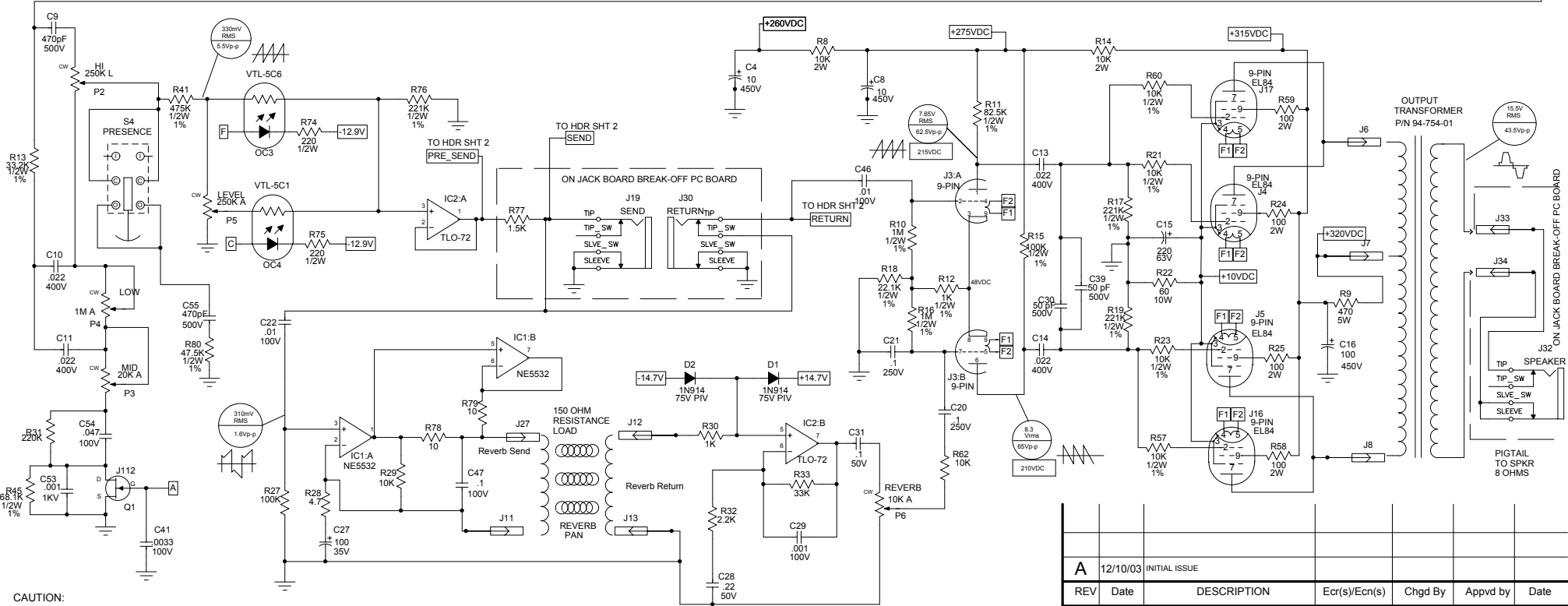
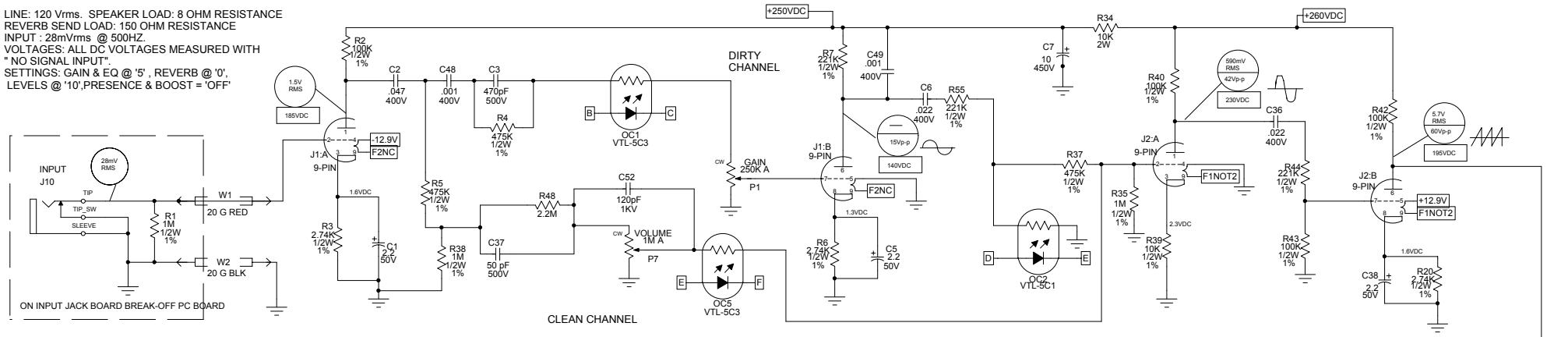

CAUTION:  
 THIS SCHEMATIC IS PROVIDED FOR USE BY QUALIFIED PERSONNEL.  
 TO AVOID RISK OF ELECTRIC SHOCK, REFER SERVICING TO QUALIFIED  
 SERVICE PERSONNEL. DO NOT PERFORM ANY SERVICING BEYOND  
 THAT EXPLAINED IN THE OPERATING INSTRUCTIONS.

- NOTES:  
 1) CAUTION: SHOCK HAZARD!!  
 THIS UNIT CONTAINS HAZARDOUS VOLTAGE. DISCONNECT POWER  
 AND BE SURE POWER SUPPLY IS DISCHARGED BEFORE  
 TOUCHING INTERNAL PARTS.  
 2) UNLESS NOTED, RESISTOR VALUES IN OHMS, 1/4W-5% TOL.  
 CAPACITOR VALUES IN MICROFARADS, 50V-10% TOL.  
 3) VOLTAGES ARE MEASURED WITH 1 MEGOHM OSCILLOSCOPE  
 AND 10 MEGOHM DIGITAL VOLTMETER.

- NOTE: NOT SPLIT TEST POINT BUBBLE = CLEAN & DIRTY  
 ○ NOTE: SPLIT TEST POINT BUBBLE  
 CLEAN=TOP RMS VOLTS ( NO WAVE FORM )  
 DIRTY=BOTTOM p-p VOLTS ( SEE WAVEFORM )  
 □ DC VOLTS

Power Table	
RefDes	+14.7V -14.7V
IC1 & IC2	8 4

REV	Date	DESCRIPTION	Ecr(s)/Ecrn(s)	Chgd By	Appvd by	Date
A	12/10/03	INITIAL ISSUE				

THE INFORMATION CONTAINED ON THIS DRAWING IS PROPRIETARY TO  
 ST. LOUIS MUSIC, INC.

Drawn:	WFB	Date:	12/10/03
Checked:		First Used On:	1901 Congressional, St. Louis, MO 63146
Released:		Drawing Title:	PWA - TUBE GUITAR AMP
Plot Date: Thu Jan 29, 2004	Drawing Size: C	Drawing Number:	07S677
Plot Time: 12:07:06	Drawing Type: Schematic	Sheet 1 of 2	

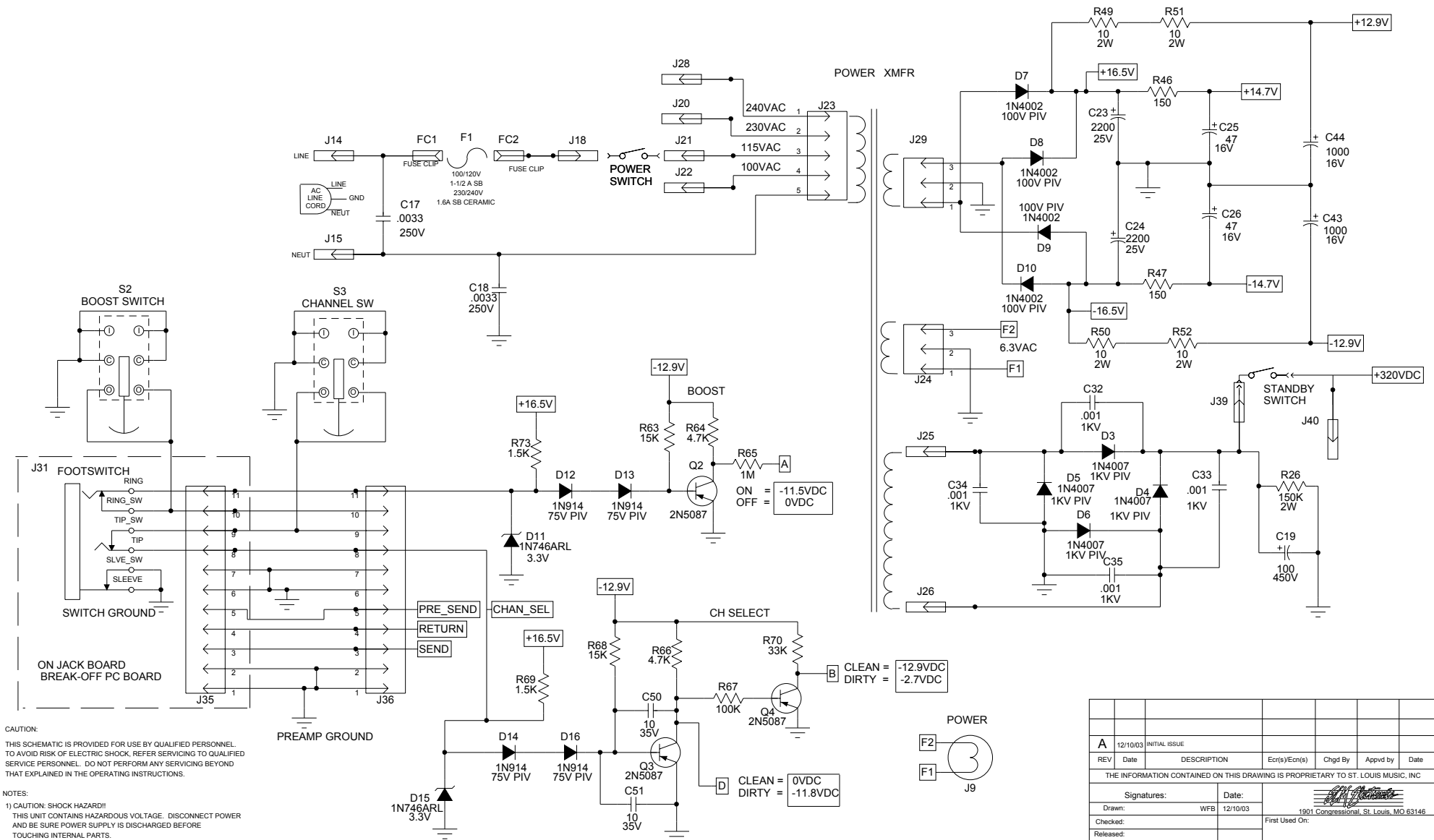

CAUTION:  
 THIS SCHEMATIC IS PROVIDED FOR USE BY QUALIFIED PERSONNEL TO AVOID RISK OF ELECTRIC SHOCK. REFER SERVICING TO QUALIFIED SERVICE PERSONNEL. DO NOT PERFORM ANY SERVICING BEYOND THAT EXPLAINED IN THE OPERATING INSTRUCTIONS.

- NOTES:
- 1) CAUTION: SHOCK HAZARD!! THIS UNIT CONTAINS HAZARDOUS VOLTAGE. DISCONNECT POWER AND BE SURE POWER SUPPLY IS DISCHARGED BEFORE TOUCHING INTERNAL PARTS.
  - 2) UNLESS NOTED, RESISTOR VALUES IN OHMS, 1/4W-5% TOL. CAPACITOR VALUES IN MICROFARADS, 50V-10% TOL.
  - 3) VOLTAGES ARE MEASURED WITH 1 MEGOHM OSCILLOSCOPE AND 10 MEGOHM DIGITAL VOLTMETER.

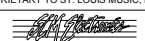
REV	Date	DESCRIPTION	Ecr(s)/Ecn(s)	Chgd By	Appvd by	Date
A	12/10/03	INITIAL ISSUE				
THE INFORMATION CONTAINED ON THIS DRAWING IS PROPRIETARY TO ST. LOUIS MUSIC, INC						
Signatures:		Date:		 1901 Congressional, St. Louis, MO 63146		
Drawn:	WFB	12/10/03	First Used On:			
Checked:						
Released:						
Plot Date:	Thu Jan 29 2004	Drawing Size:	B		Drawing Title:	
Plot Time:	12:07:07	Drawing Type:	Schematic		PWA - TUBE GUITAR AMP	
Tolerance:		Class Code:	NONE		Drawing Number:	
		Sheet	2 of 2			

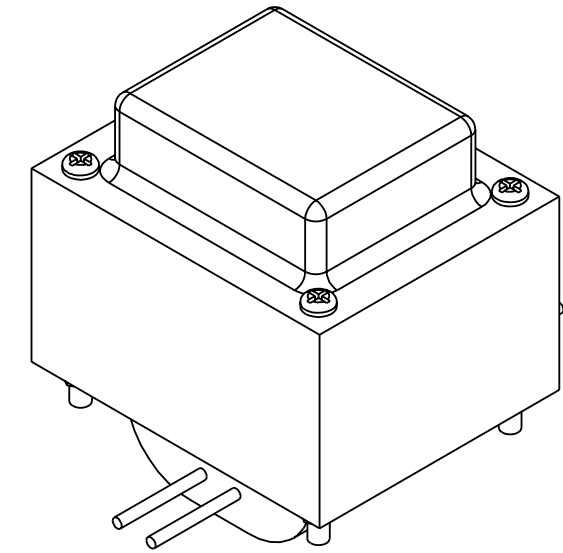
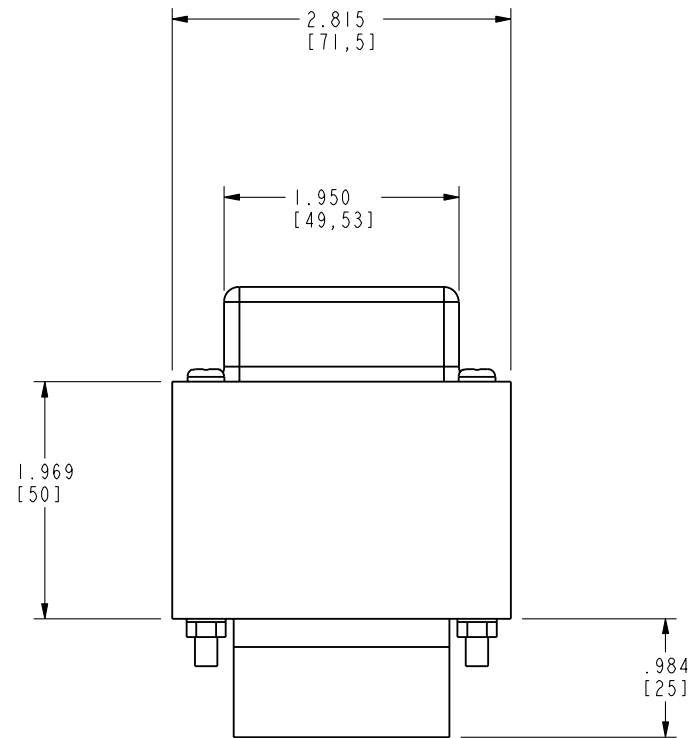
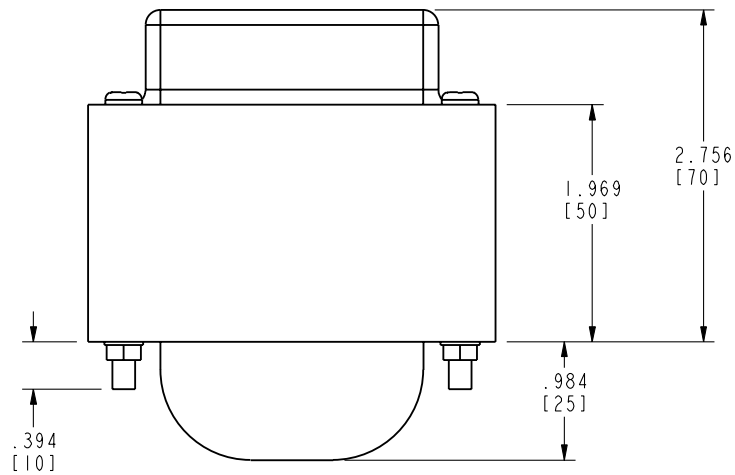
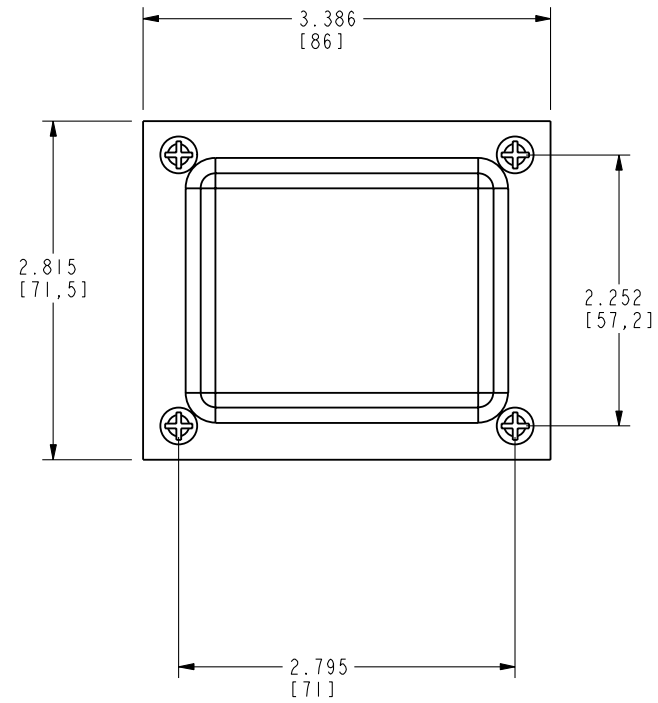

-02

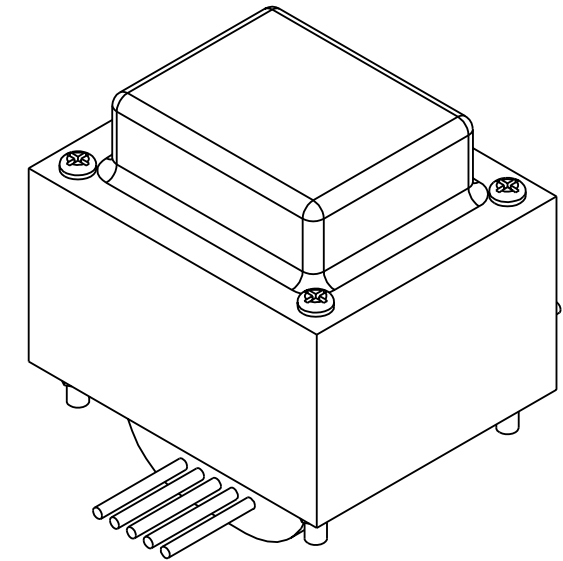

-41

SOURCE CONTROL DRAWING

APPROVED SAMPLE #	VENDOR PRINT FILE #	SLM PART #	NAME & ADDRESS OF VENDOR
CMEC1202	VPF00122	94-269-02	CHUANG MEEI ELEC. KAOSIUNG, TAIWAN
CMEC1202	VPF00122	94-269-41	CHUANG MEEI ELEC. KAOSIUNG, TAIWAN

REV:	DATE:	DESCRIPTION	ECR/ECN NO:	CHNG'D BY:	APPR'D BY:	DATE:
1	08/19/04	ADD CIRCUIT SCHEMATIC UPDATE SPEC TABLES	N01579	DDG		
0	01/06/03	CONTROL ISSUE		JRC		

THE INFORMATION CONTAINED ON THIS DRAWING IS PROPRIETARY TO ST. LOUIS MUSIC, INC.

SIGNATURES:		DATE:	 St. Louis, Missouri U.S.A.
DRAWN:	JRC	19-Aug-04	
CHK'D:			DRAWING TITLE: <b>TRANSFORMER</b>
RLS'D:			
TOLERANCES:	DRAWING SIZE: 26 by 16.8	DRAWING NO.: 94-269-XX	
	DRAWING TYPE: CLASS CODE:		
SCALE: 1.000	SHEET: 1 of 3		

94-269-02 Lead Wire Specification

Item	Description	Color	Gage	Length	Terminals
1	Primary:	120V Hot	BLACK	18AWG	8.0 inches J1 Pos.#3, 5-pin AllIX80 99 Housing. 94T terminal
2	Primary:	N	WHITE	18AWG	8.0 inches J1 Pos.#5, 5-pin Alex 8099 Housing. 94T terminal
3	Secondary #1	RED	18AWG	8.0 inches	0.250x0.032 Fully Insulated Female Spade
4	Secondary #1	RED	18AWG	8.0 inches	0.250x0.032 Fully Insulated Female Spade
5	Secondary #2	ORANGE	18AWG	9.0 inches	J2 Pos.#1, 3-pin JST .156 ctn. Housing & Crimp Terminal
6	Secondary #2 : Center Tap	YELLOW	18AWG	9.0 inches	J2 Pos.#2, 3-pin JST .156 ctn. Housing & Crimp Terminal
7	Secondary #2	ORANGE	18AWG	9.0 inches	J2 Pos.#3, 3-pin JST .156 ctn. Housing & Crimp Terminal
8	Secondary #3	RED	18AWG	6.0 inches	J3 Pos.#1, 3-pin JST .156 ctn. Housing & Crimp Terminal
9	Secondary #3 : Center Tap	GREEN	18AWG	6.0 inches	J3 Pos.#2, 3-pin JST .156 ctn. Housing & Crimp Terminal
10	Secondary #3	RED	18AWG	6.0 inches	J3 Pos.#3, 3-pin JST .156 ctn. Housing & Crimp Terminal

Note: Wire lengths are measured from transformer endbell to termination housing

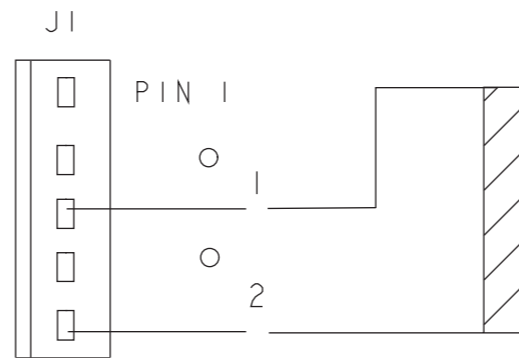

Service Type: Audio Power Amplifier  
Temperature Class: Class B max.

Compliance Notes:

- Transformer must comply with UL1411, UL6500, CSA E60065, and CE E60065 Standards
- Transformer must be marked to identify manufacturer and SLME Part Number

Construction Notes:

- Low radiated field intensity is required - windings are to be wound at evenly spaced turns around the full circumference of the core.
- Magnetizing current at high line (110%) of supply voltage must be less than two times the magnetizing current at minimum line (90%) of supply voltage.

Item	Description	Minimum/Nominal Line		Max. High Line (110%)	
		(Rd. Schematic) Voltage	Current	Voltage	Current
Primary 120V	1 Line Hot	120Vac 60Hz	-----	132Vac 60Hz	-----
	2 Line N				
Secondary #1	3 & 4 Output	+315 Vdc	0.35 Adc	+348.0 Vdc	0.10 Adc
Secondary #2	5 & 7 Output.	63Vac	3.0 Aac	7.0 Vac	0.10 Aac
	6 Center Tap				
Secondary #3	8 & 10 Output.	± 16.0 Vdc	0.30 Adc	± 17.75 Vdc	0.05 Adc
	9 Center Tap				

Note: --- indicates data not relevant to functional specifications

TYPICAL APPLICATION CIRCUIT

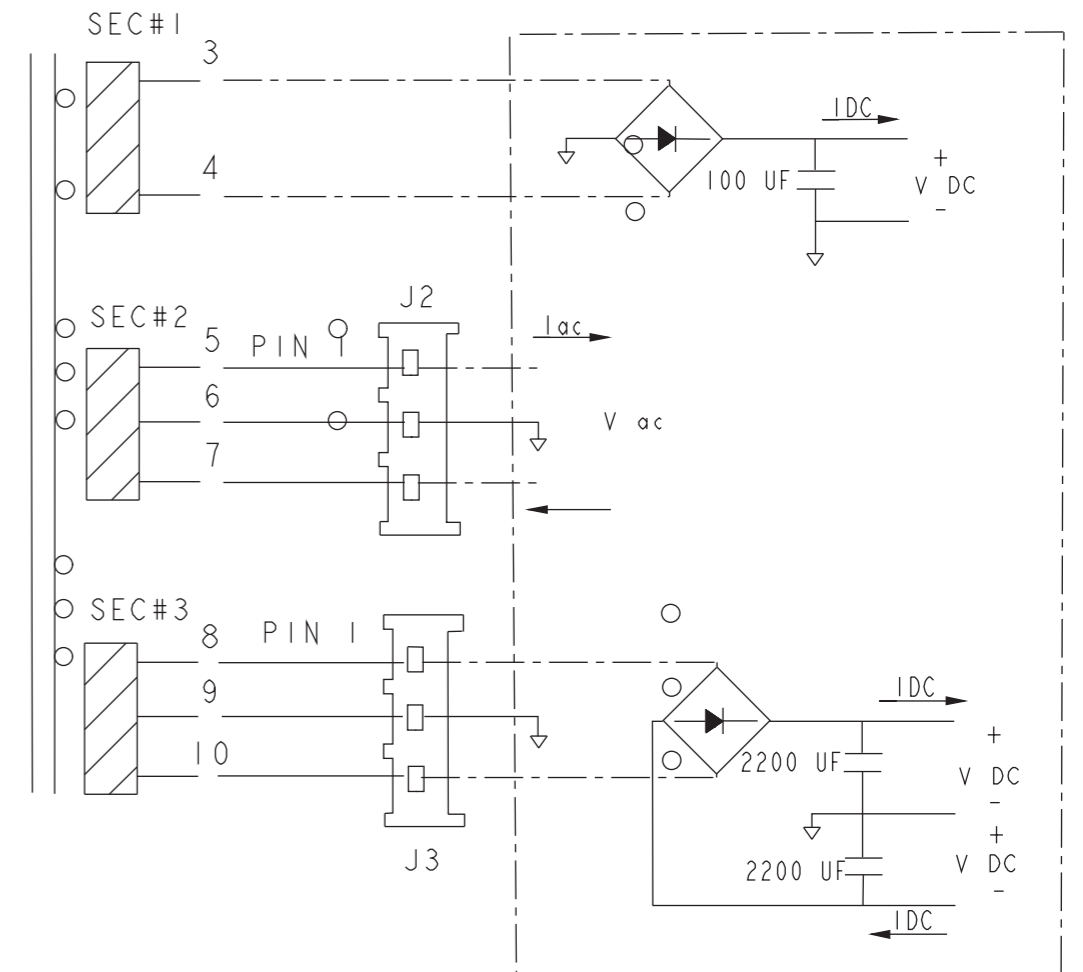

-02

1	08/19/04	ADD CIRCUIT SCHEMATIC UPDATE SPEC TABLES	N01579	DDG		
0	01/06/03	CONTROL ISSUE		JRC		
REV:	DATE:	DESCRIPTION	ECR/ECN NO:	CHNG'D BY:	APPR'D BY:	DATE:
THE INFORMATION CONTAINED ON THIS DRAWING IS PROPRIETARY TO ST. LOUIS MUSIC, INC.						
SIGNATURES:			DATE:			
DRAWN:	JRC		19-Aug-04			
CHK'D:						
RLS'D:						
TOLERANCES:	DRAWING SIZE: 26 by 16.8		DRAWING TITLE:			
	DRAWING TYPE:		TRANSFORMER			
	CLASS CODE:		DRAWING NO.:			
SCALE:	0.500	SHEET: 2 of 3	94-269-XX			

94-269--41 Lead Wire Specification

Item	Description	Color	Gage	Length	Terminals
1	Primary. 240V Hot	BROWN	18AWG	8.0 inches	J1 Pos.#1, 5-pin Alex 8099 Housing. 94T terminal
2	Primary. 230V Hot	GRY/WHT	18AWG	8.0 inches	J1 Pos.#2, 5-pin Alex 8099 Housing, 94T terminal
3	Primary.120V Hot	BLACK	18AWG	8.0 inches	J1 Pos.#3, 5-pin Alex 8099 Housing. 94T terminal
4	Primary. 100V Hot	BLUE	18AWG	8.0 inches	J1 Pos.#4, 5-pin Alex 8099 Housing, 94T terminal
5	Primary. N	WHITE	18AWG	8.0 inches	J1 Pos.#5, 5-pin Alex 8099 Housing, 94T terminal
6	Secondary #1	RED	18AWG	8.0 inches	0 .250x0 .032 Fully Insulated Female Spade
7	Seconda~ #1	RED	18AWG	8.0 inches	0 .250x0 .032 Fully Insulated Female Spade
8	Secondary #2	ORANGE	18AWG	9.0 inches	J2 Pos.#1, 3-pin JST .156 ctn. Housing & Crimp Terminal
9	Secondary #2 : Center Tap	YELLOW	18AWG	9.0 inches	J2 Pos.#2, 3-pin JST .156 ctn. Housing & Crimp Terminal
10	Secondary #2	ORANGE	18AWG	9.0 inches	J2 Pos.#3, 3--pinJ ST .156 ctn. Housing & Crimp Terminal
11	Secondary #3	RED	18AWG	6.0 inches	J3 Pos.#1, 3-pin JST .156 ctn. Housing & Crimp Terminal
12	Secondary #3 : Center Tap	GREEN	18AWG	6.0 inches	J3 Pos.#2, 3-pin JST .156 ctn. Housing & Crimp Terminal
13	Secondary #3	RED	18AWG	6.0 inches	J3 Pos.#3, 3-pin JST .156 ctn. Housing & Crimp Terminal

Note: Wire lengths are measured from transformer endbell to termination housing

**Service Type: Audio Power Amplifier**  
**Temperature Class: Class B max.**

**Compliance Notes:**

1. Transformer must comply with UL1411, UL6500, CSA E60065, and CE E60065 Standards
2. Transfonner must be marked to identify manufacturer and SLME Part Number

**Construction Notes:**

1. Low radiated feild intensity is required - windings are to be wound atevenly spaced turns around the full circumference of the core.
2. Magnetized current at high line (110%) of supply voltage must be less than two times the magnetizing current at minimum ine (90%) of supply voltage.

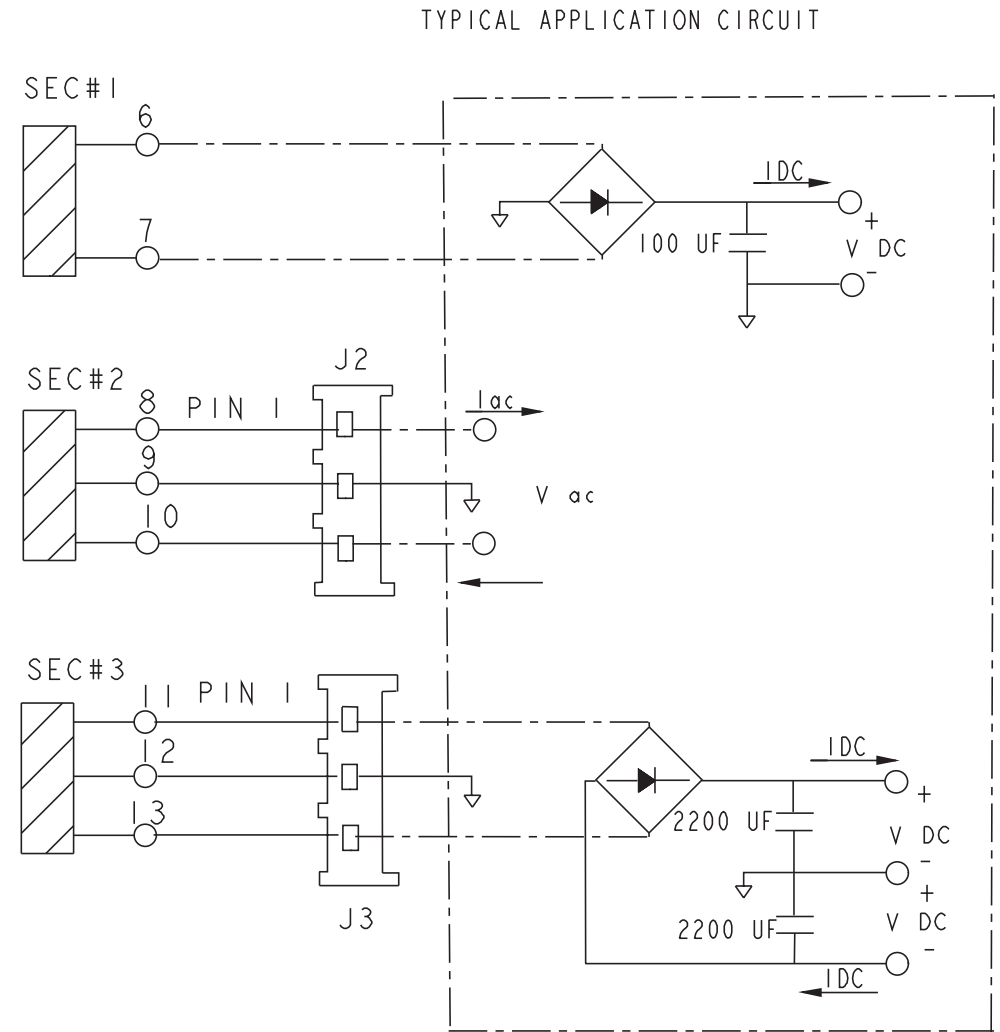
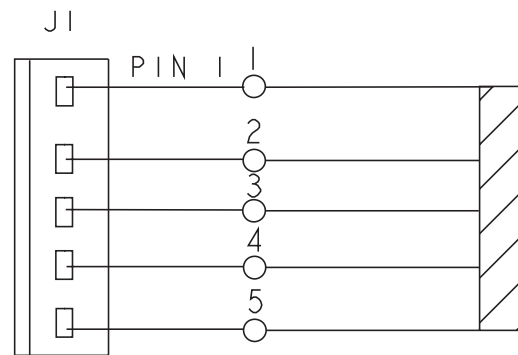

-41

Item	Description	Minimum/Nominal Line		Max. High Line (1101)	
		Voltage	Current	Voltage	Current
Primary 240V	1 Line Hot 5 Line N	240Vac 50Hz	-----	264Vac 50Hz	-----
Primary 230V	2 Line Hot 5 Line N	230Vac 50Hz	-----	254Vac 50Hz	-----
Primary 120V	3 Line Hot 5 Line N	120Vac 60Hz	-----	132Vac 60Hz	-----
Primary 100V	4 Line Hot 5 Line N	100Vac 50/60Hz	-----	110Vac 50/60Hz	-----
Secondary #1	6 & 7 Output	+315 Vdc	035 Adc	348.0 Vdc	0.10 Adc
Secondary #2	8 & 10 Output, 9 Center Tap	63Vac	3.0 Aac	7.0 Vac	0.10Aac
Secondary #3	11 & 13 Output, 12 Center Tap	± 16.0Vdc	030Aadc	± 17.75 Vdc	0.05 Adc

Note: \* - - \* indicates data not relivent to functional specifications

SOURCE CONTROL DRAWING

1	08/19/04	ADD CIRCUIT SCHEMATIC UPDATE SPEC TABLE	N01579	DDG		
0	01/06/03	CONTROL ISSUE		JRC		
REV:	DATE:	DESCRIPTION	ECR/ECN NO:	CHNG'D BY:	APPR'D BY:	DATE:
THE INFORMATION CONTAINED ON THIS DRAWING IS PROPRIETARY TO ST. LOUIS MUSIC, INC.						
SIGNATURES:			DATE:			
DRAWN:	JRC		19-Aug-04			
CHK'D:						
RLS'D:						
TOLERANCES:	DRAWING SIZE: 26 by 16.8		DRAWING TITLE:			
	DRAWING TYPE:		TRANSFORMER			
	CLASS CODE:		DRAWING NO.:			
SCALE:	0.500	SHEET:	3 of 3		94-269-XX	