

HW?
MICA

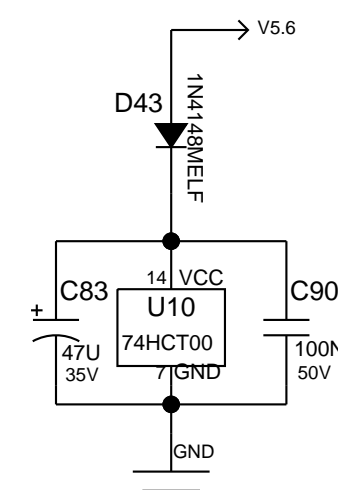

PEAVEY
Peavey Electronics Corp.
P. O. Box 2898
Meridian, MS 39301

PVI_AMPLIFIER_PVI6500_AMP
AMPLIFIER

Sheet Title:
C Sheet 3 of 4 Date: 7-22-2011_16:26

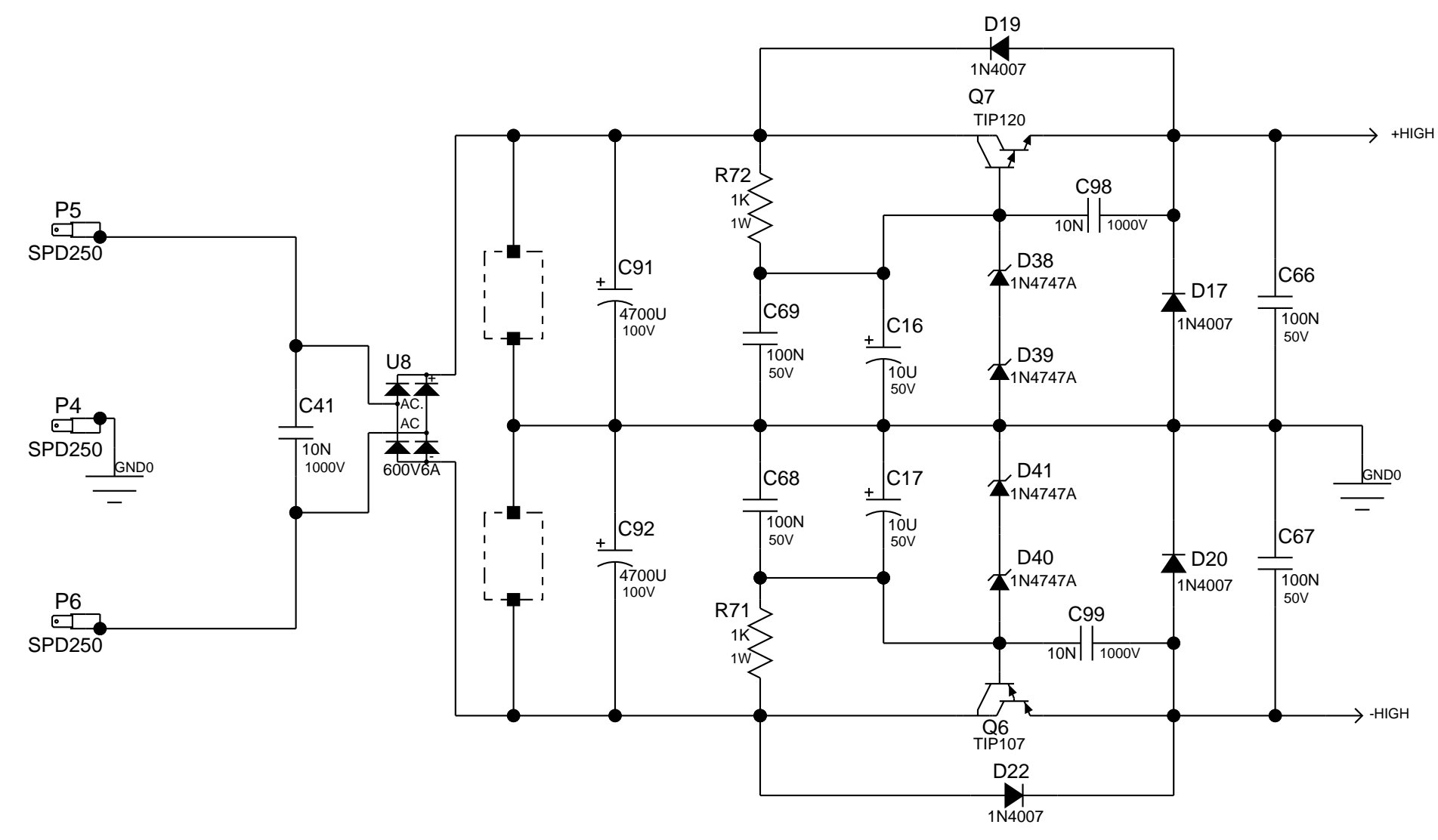

POWER AMP INTERCONNECT

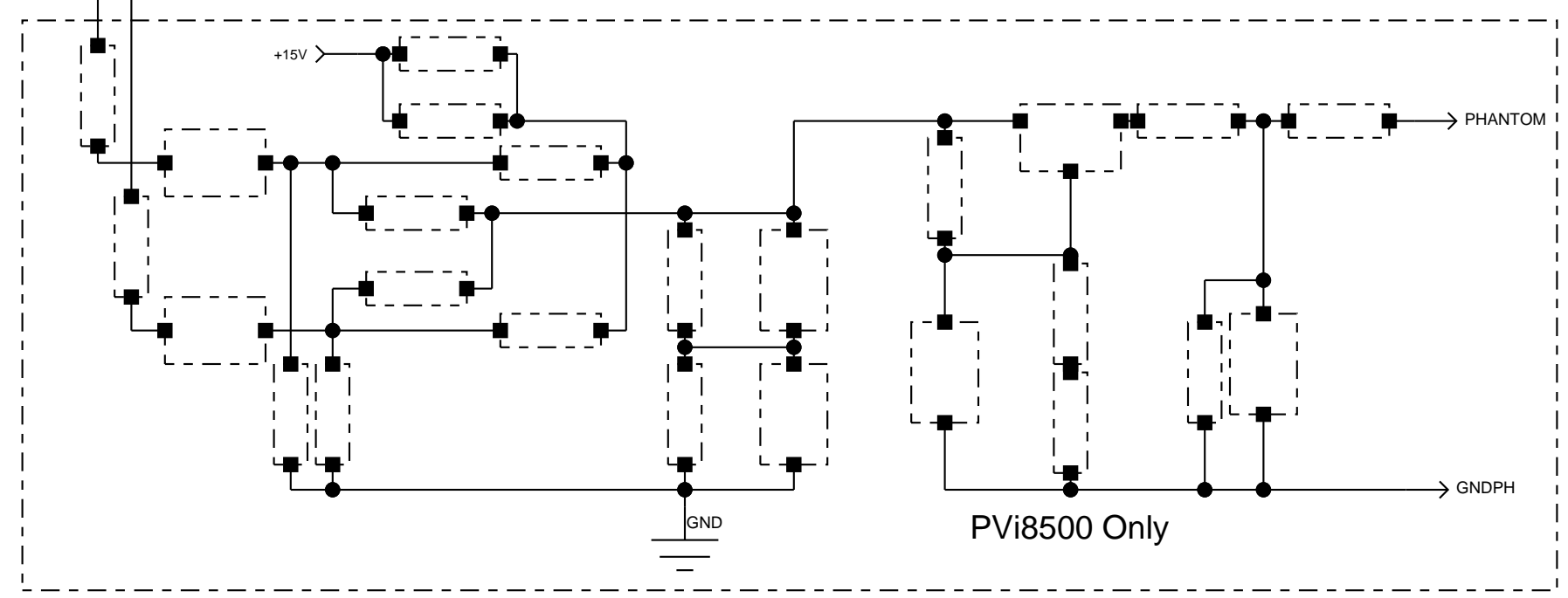
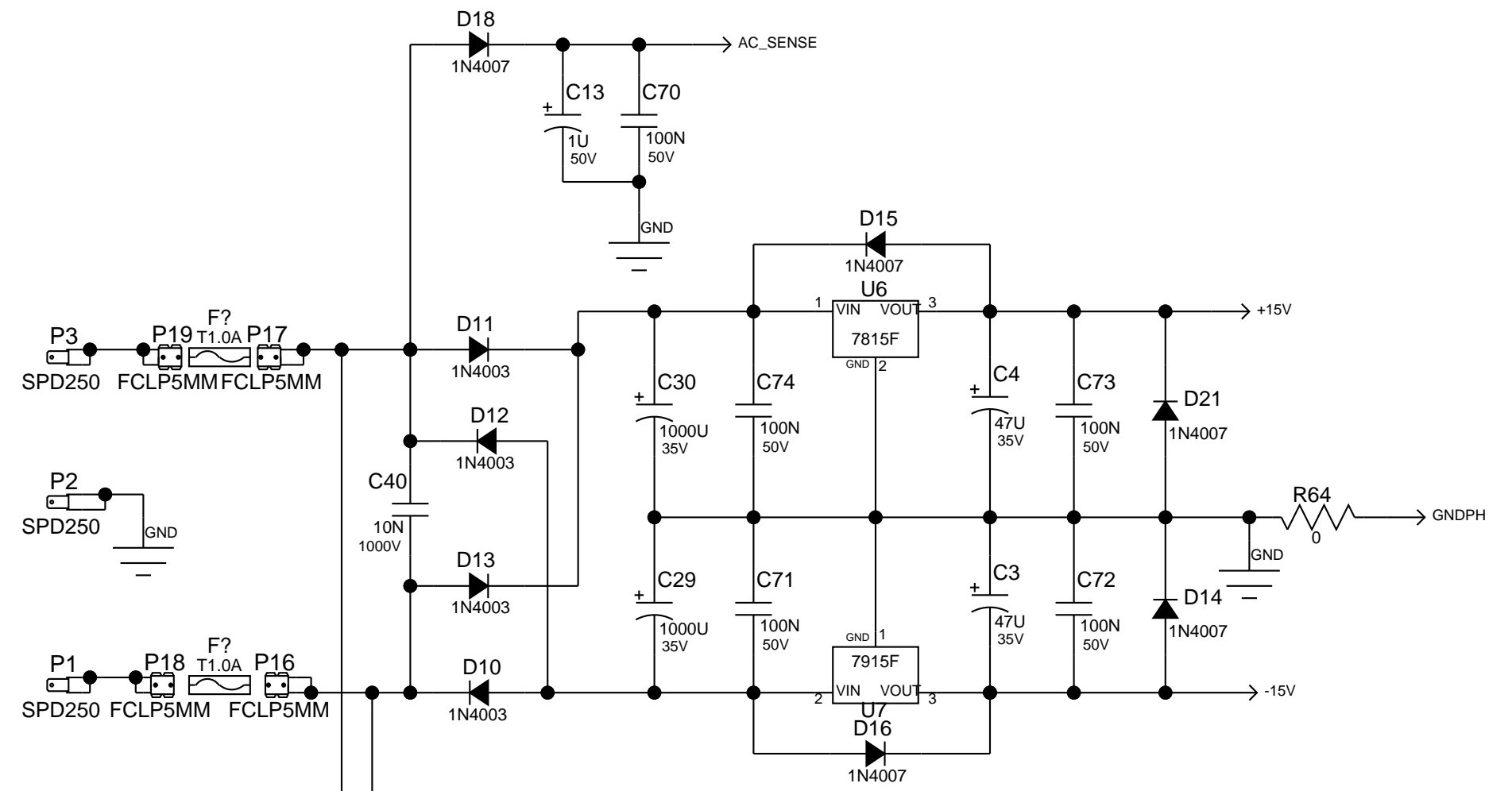
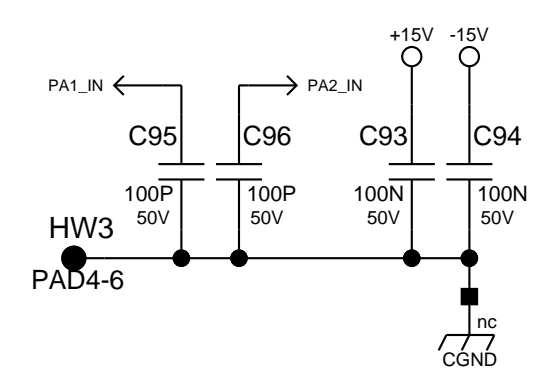
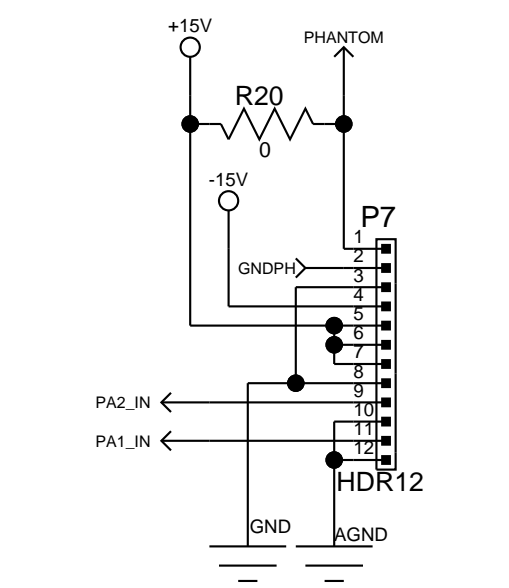

PVI_AMPLIFIER_PVI6500_AMP
 Sheet Title: POWER SUPPLY

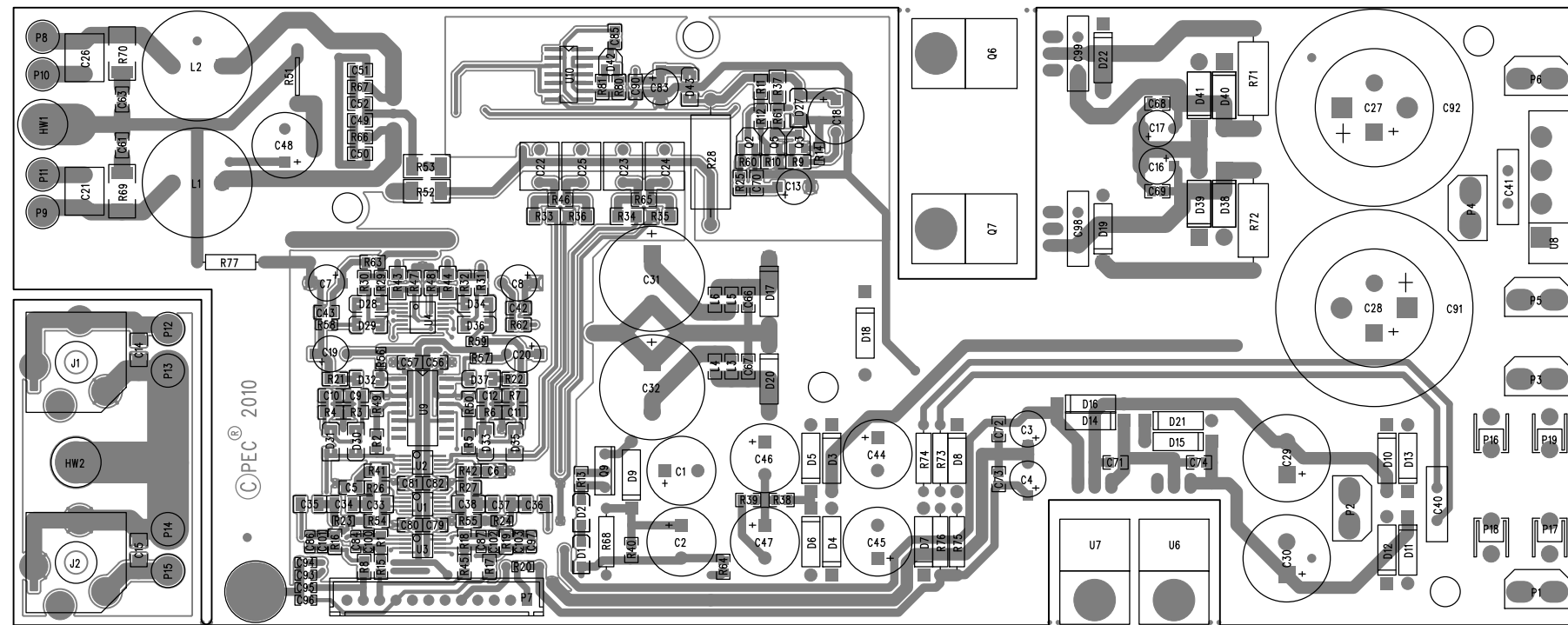

PV6500/8500 POWER AMP - PRIMARY SIDE VIEW

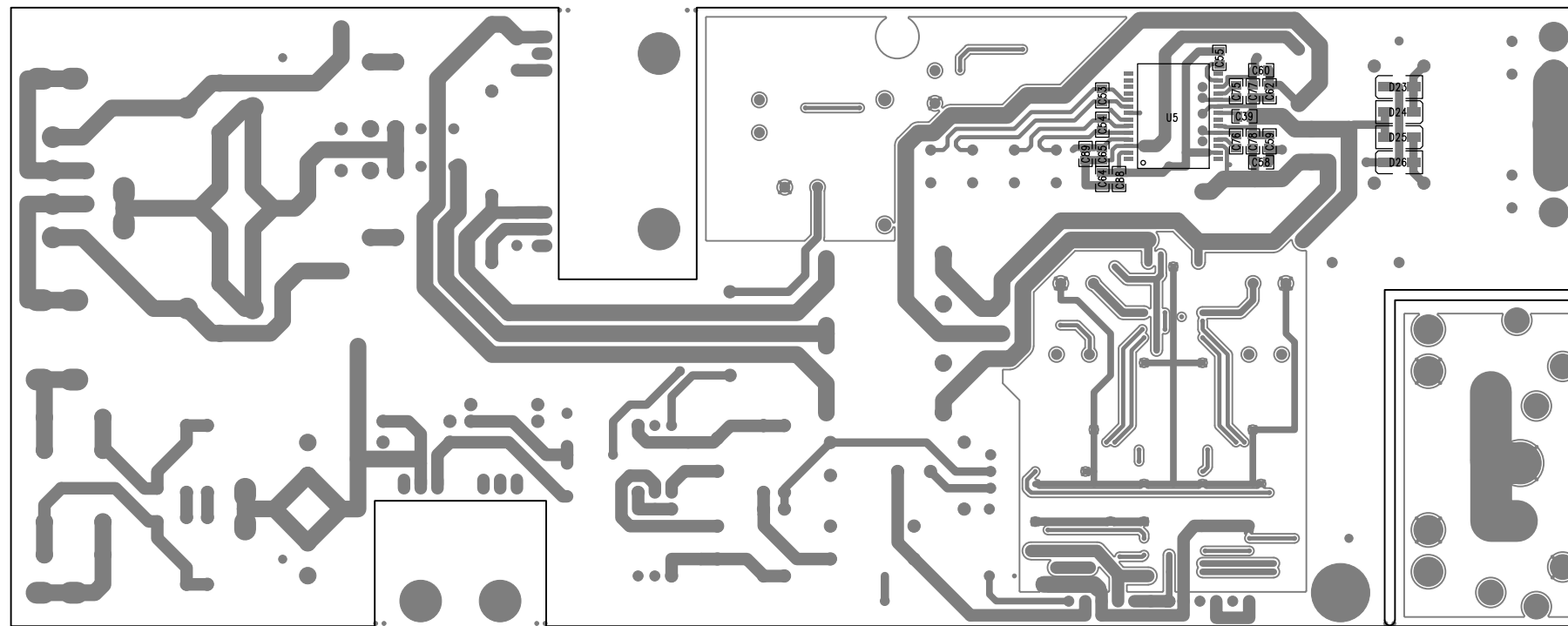

PV6500/8500 POWER AMP - PRIMARY SIDE VIEW

BILL OF MATERIAL REPORT

REPORT DATE/TIME: 7/25/2011 10:29:41 AM

BOARD NAME: PVi 6500 Power Amp ASSEMBLY LEVEL NUMBER: 32200931

PROJECT NUMBER: P1000086 DESIGNER: FJE - 32101801

Qty.	Part #	Description	Reference
Designators			

2	30200051	10K 1/4W 1% MF 1206	R43 R44
5	30200118	5.62K 1/4W 1% MF 1206	R33 R34 R35 R36 R37
1	30200164	0.0 JUMPER SMT 0805	R64
20	30200174	10K 1/10W 1% MF 0805	R1 R2 R3 R4 R5 R6 R7 R8 R9 R10 R11 R12 R15 R16 R17 R18 R19 R45 R46 R65
1	30200188	1.00K 1/10W 1% MF 0805	R81
2	30200196	10 1/10W 1% MF 0805	R66 R67
3	30200198	499 1/10W 1% MF 0805	R47 R48 R80
2	30200200	8.25K 1/10W 1% MF 0805	R26 R27
2	30200238	22 1W 5% MF 2512	R69 R70
2	30200241	4.70 1/10W 1% MF 0805	R62 R63
4	30200251	4.75K 1/10W 1% MF 0805	R29 R30 R31 R32
1	30200256	22.1K 1/10W 1% MF 0805	R60
1	30200281	0.0 JUMPER 0.1 0603	R20
1	30200288	100K 1/10W 5% MF 0603	R14
2	30200292	15K 1/10W 5% MF 0603	R23 R24
2	30200294	1K 1/10W 1% MF 0603	R58 R59

2	30200305	30.1K	1/10W	1%	MF	0603	R56 R57
2	30200331	49.9K	1/10W	1%	MF	0805	R41 R42
2	30200337	82.5K	1/10W	1%	MF	0805	R54 R55
1	30200342	221K	1/10W	1%	MF	0805	R25
2	30200358	10	1/2W	1%	MF	2010	R52 R53
2	30200373	200	1/10W	1%	MF	0805	R49 R50
2	30200376	12.1K	1/10W	1%	MF	0805	R21 R22
1	30200408	2.87K	1/10W	1%	MF	0805	R61
2	30210000	1K	1W	5%	MO	AXL	R71 R72
1	30210122	1.5K	3W	5%	MO	T&R	R28
6	30300069	0.22UF	50V	10%	X7R	1206	C33 C34 C35 C36 C37 C38
7	30300089	220PF	50V	5%	NPO	0805	C49 C50 C51 C52 C53 C54 C55
30	30300093	0.1UF	50V	10%	X7R	0805	C9 C10 C11 C12 C42 C43 C56 C57 C58 C59 C60 C62 C64 C65 C66 C67 C68 C69 C70 C71 C72 C73 C74 C79 C80 C81 C82 C88 C89 C90
2	30300128	0.1UF	50V	□20%	Y5V	0603	C93 C94
2	30300133	100PF	50V	5%	NPO	0603	C95 C96
4	30300138	33PF	50V	5%	NPO	0603	C100 C101 C102
C103							
1	30300147	680PF	50V	5%	NPO	0805	C85
2	30300154	0.015UF	50V	10%	X7R	0805	C75 C76
2	30300159	68PF	50V	5%	NPO	0805	C5 C6
4	30300232	10PF	50V	5%	NPO	0603	C84 C86 C87 C97
4	30300249	0.1UF	100V	20%	X7R	0805	C61 C63 C77 C78

2	30300273	270PF 500V 5% NPO 1206	C14 C15
1	30300320	470NF 50V 10% X7R 0805	C39
4	30320099	0.01UF 1000V 80-20% Z5U	C40 C41 C98 C99
2	30320181	22UF 50V 20% EL RAD	C7 C8
2	30320185	10UF 50V 20% ELL RAD	C16 C17
2	30320186	1000UF 35V 20% EL RAD	C29 C30
1	30320261	1UF 50V 20% EL RAD	C13
1	30320265	100UF 16V 20% EL RAD	C18
2	30320319	2200UF 50V 20% EL RADH	C31 C32
5	30320344	47UF 35V 20% EL RAD	C3 C4 C19 C20 C83
1	30320704	47UF 100V 20% ELS RAD	C48
6	30330159	0.47UF 63V 5% PES RAD	C21 C22 C23 C24 C25 C26
1	30400318	7815F " INS TO-220F HOR	U6
1	30400319	7915 -15V INS TO-220F HOR	U7
1	30400605	BR RECT INLINE 600V 6A	U8
1	30400800	TIP-120 NPN DARL PWR TRAN	Q7
1	30402153	TIP-107 PNP DARL T0220	Q6
4	30404747	1N4747A 20V, 1W ZENER, 5%	D38 D39 D40 D41
11	30418026	1N4148 (LL34) DIODE SMT	D28 D29 D30 D31 D32 D33 D34 D35 D36 D37 D43
1	30418042	74HCT00 4- 2IN NAND SO14	U10
2	30418051	MMBTA13LTI NPN DARL. SMT	Q2 Q3
1	30418135	2N3904 NPN SOT23	Q5
1	30418231	NJM13700 DUAL OTA SMT	U9

4	30418261	1N4003 - SMT - SMA PKG	D23 D24 D25 D26
1	30418546	5.6V ZENER (SOD123)-SMT	D27
1	30418649	LM339 QUAD COMPARATOR TSSOP	U4
1	30418655	BAV99L DUAL 4148 DIODE SO	D42
3	30418835	NJM4565 DUAL OPAMP SSOP8	U1 U2 U3
1	30418904	TDA8954 CLASS D POWER AMP	U5
4	30464003	1N4003 200V 1A SI DIODE	D10 D11 D12 D13
9	30464007	1N4007 1KV, 1A, SI DIODE	D14 D15 D16 D17 D18 D19 D20 D21 D22
2	30504103	22UH, 5A INDUCTOR	L1 L2
4	30519982	FERRITE BEAD 3A SMT	L3 L4 L5 L6
1	30600136	0 OHM 22GA JMPR AXL	R51
4	30901714	FUSE CLIP, 5 X 20MM -T&A	P16 P17 P18 P19
2	30901888	4-40X.25X.125--BRASS	HW1 HW2
2	31466215	2 TIP HID JACK INSU W/SPD	J1 J2
1	33716730	12 HDR V SR 2.5MM TIN	P7
6	33719167	SPADE .250 PC MNT BULK	P1 P2 P3 P4 P5 P6
2	70320404	4700UF 100V 20% EL SNPH	C91 C92
8	CABL13817	16GA W/CRIMP TERM 73713817	P8 P9 P10 P11 P12 P13 P14 P15

 END OF BILL OF MATERIAL REPORT
