



# Service Manual

Created: 14 March 2015



## BLUE DEVIL GX112

**Ultra-Flexible 60-Watt Guitar Workstation with Digital Multi-Effects Processor**

Specifications ..... 2

[behringer.com](http://behringer.com)



# BLUE DEVIL GX112

## Specifications

- Powerful 60-Watt guitar workstation with authentic Virtube tube emulation
- Original heavy-duty 12" Jensen® / BUGERA™ guitar speaker
- 2 independent channels with separate Volume controls and effects
- "Heaven" channel delivers clean tube sounds
- "Hell" channel offers a broad range, from modern crunch to high-gain sounds
- Dedicated vintage-type 3-band EQ
- 24-bit stereo multi-effects processor with ultra-high resolution 24-bit A/D and D/A converters
- 31 original VIRTUALIZER/MODULIZER presets with world-class effects such as Reverb, Delay, Phaser, Chorus, Flanger, Pitch Shifter, Speaker Simulator, Compressor, Expander, Wah, Tube Emulator and various effects combinations
- 99 outstanding and easy-to-edit user presets
- Quasi-analog operation: 3 FX parameters per preset can be edited with dedicated controls
- Adjustable Aux input for playback or other line-level signals (e. g. CD player, drum computer, etc.)
- Stereo Line output for recording and live applications
- Insert facility for external effects devices (stomp boxes, wah-wah pedals, etc.)
- Channel select and FX bypass footswitch FS112 included
- Complete MIDI implementation for channel and effect selection as well as real-time control
- Master volume control and stereo Headphone output
- Robust power supply ensures excellent transient response
- High-quality components and exceptionally rugged construction ensure long life
- Conceived and designed by BEHRINGER Germany

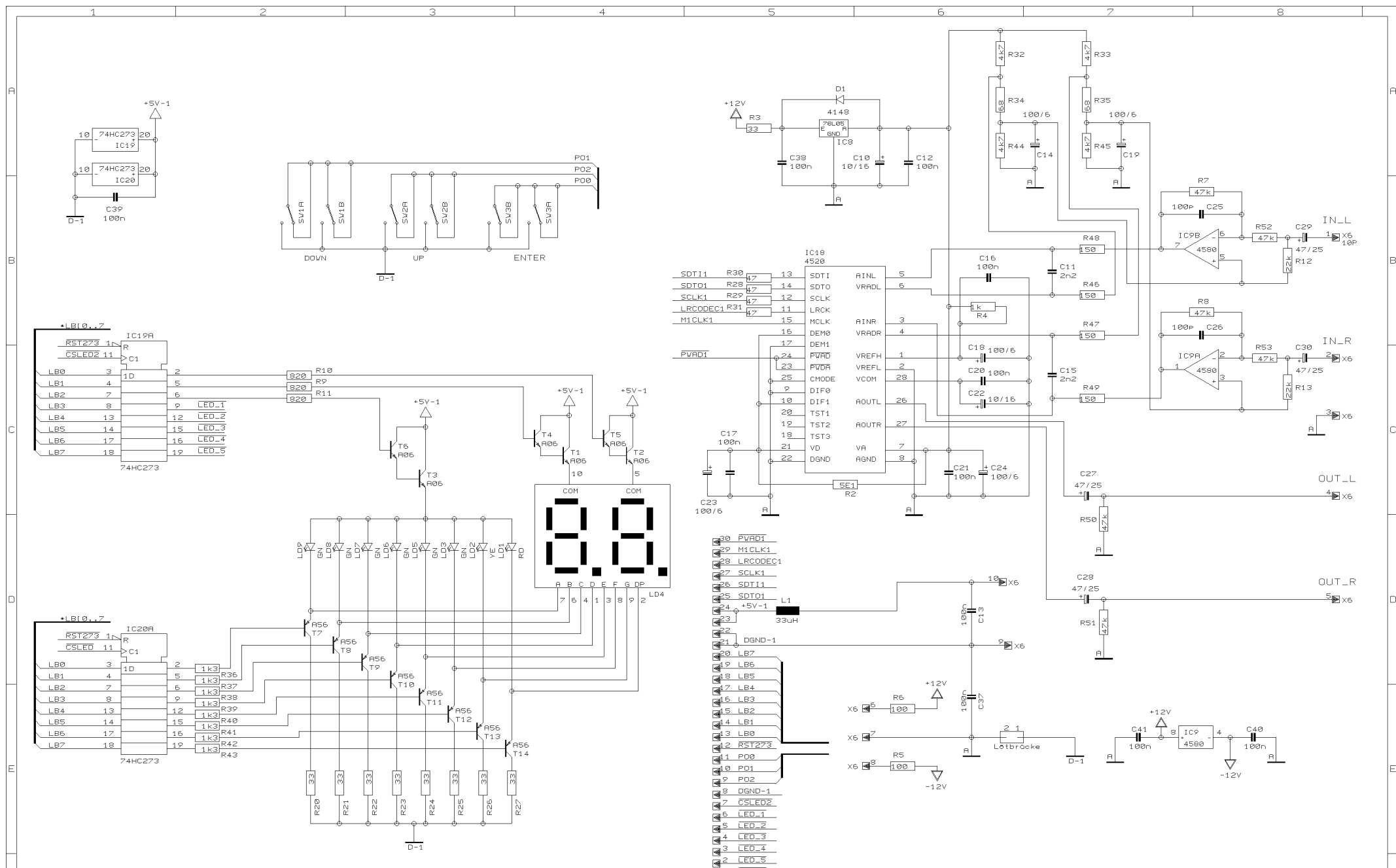

REVISIONS C (100599)

DRAWN CHECKED DATE 19.02. 1 11:03



PROJECT DPM2 MULTI-FX MODULE I/O SECTION SHEET 1 OF 2 SHEETS TOTAL

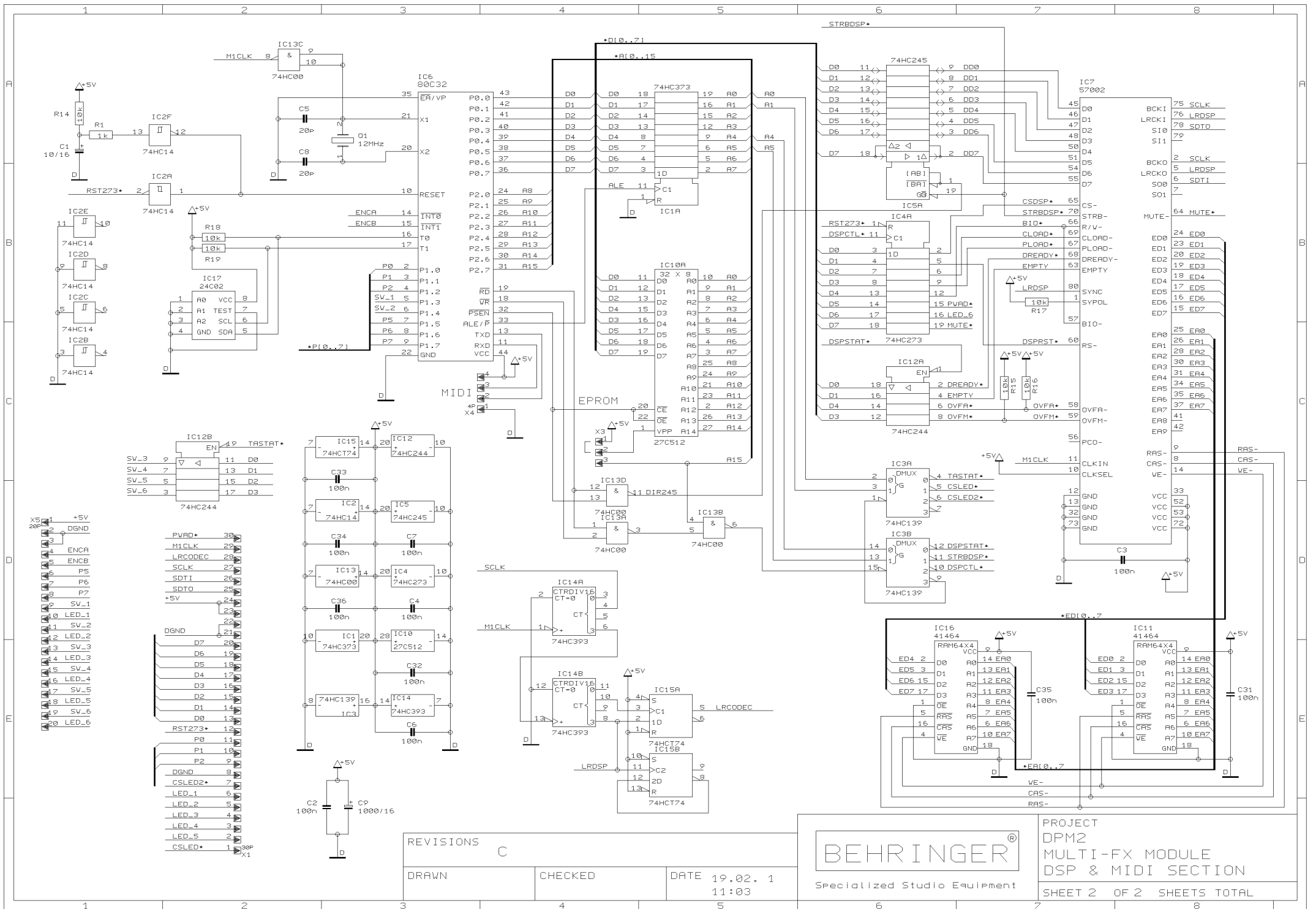

REVISIONS		
C		
DRAWN	CHECKED	DATE 19.02. 1 11:03



PROJECT  
DPM2  
MULTI-FX MODULE  
DSP & MIDI SECTION  
SHEET 2 OF 2 SHEETS TOTAL

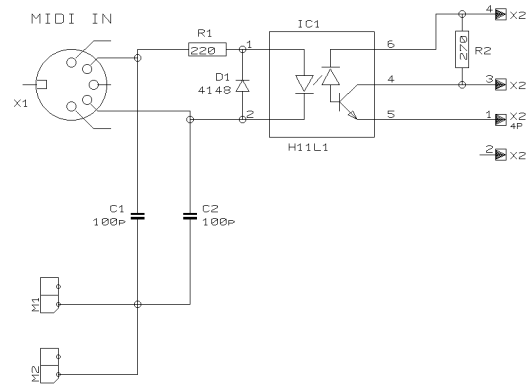

REVISIONS C (210599)

DRAWN BK

CHECKED

DATE 19.02. 1  
11:07

**BEHRINGER**<sup>®</sup>  
Specialized Studio Equipment

PROJECT  
MIDI-GX1  
MIDI INTERFACE:  
GX112

SHEET 1 OF 1 SHEETS TOTAL

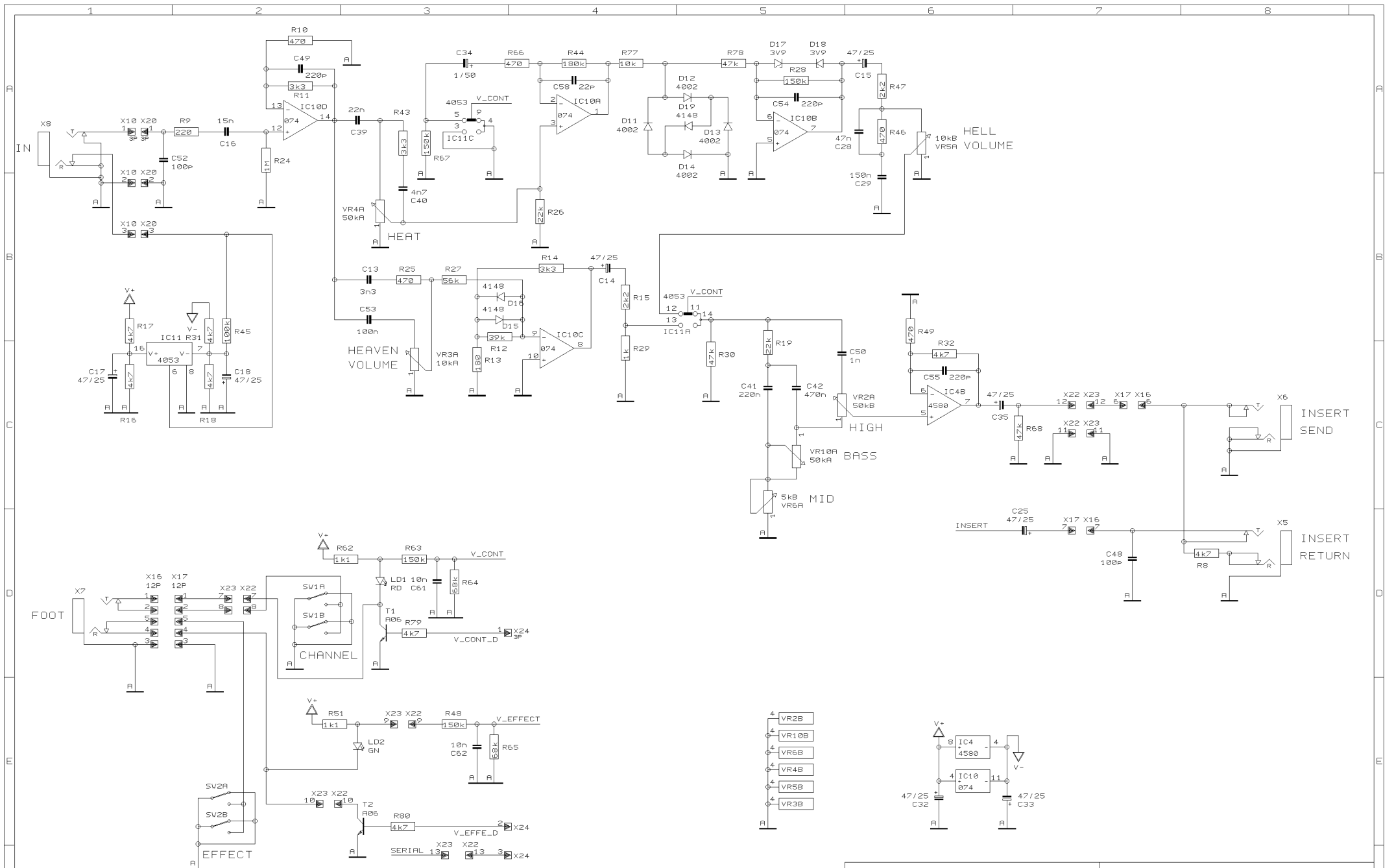

REVISIONS  
C

DRAWN BK

CHECKED

DATE 19.02. 1  
11:08



PROJECT  
GX112  
BLUE DEVIL  
INPUT SECTION  
SHEET 1 OF 3 SHEETS TOTAL

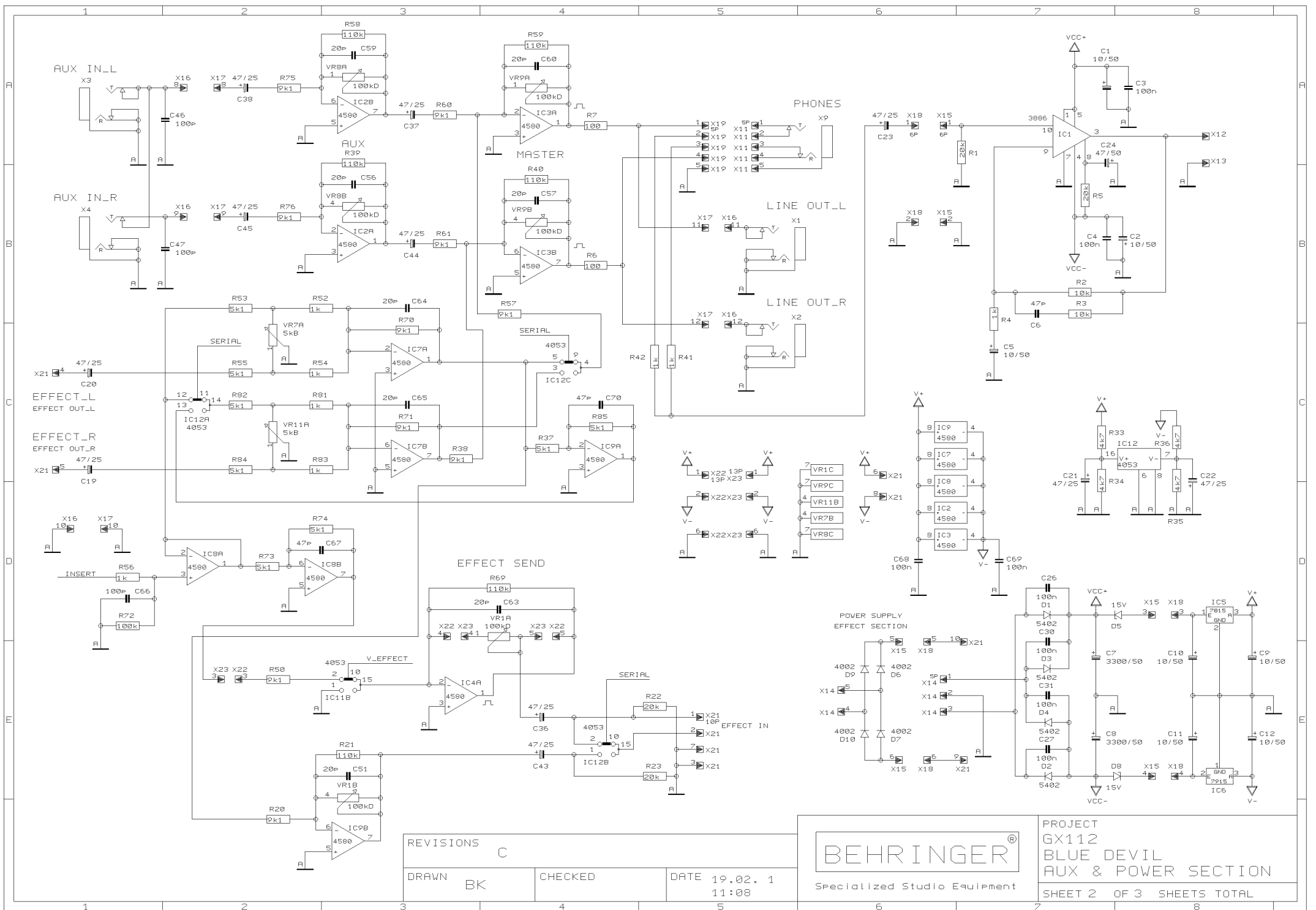

REVISIONS

C

DRAWN BK

CHECKED

DATE 19.02. 1  
11:08

BEHRINGER®

Specialized Studio Equipment

PROJECT  
GX112  
BLUE DEVIL  
AUX & POWER SECTION

SHEET 2 OF 3 SHEETS TOTAL

	1	2	3	4	5	6	7	8	
A									
B									
C									
D									
E									
	1	2	3	4	5	6	7	8	
			REVISIONS			 Specialized Studio Equipment		PROJECT GX112	
		DRAWN	CHECKED	DATE 19.02. 1 11:08	SHEET 3 OF 3 SHEETS TOTAL				







We Hear You