

Service Manual

250ML

250RL

212SCL

Table of Contents

Operating Instructions	3
Turn On / Calibration Procedure	6
Schematics	9
Bill of Materials	15

Operating Instructions 250ML/RL/212SCL

The Basics

Your new G-K stereo guitar amplifier represents the very latest advances technology has to offer. It was designed to provide you with any sound you need and more. With the stereo effects, (Echo & Chorus), the pre-set gain switches, the channel switching and companding on the clean channel there are over 20 different sounds available.

The active four band equalizer (shared by both channels) works extremely well in both the clean and overdriven modes. You can actually EQ your overdriven sound, a rare feature in its own right. This amplifier has many other features, all described here. A careful examination of this manual will help you to get the most from them.

Input Jack

The input jack is a standard 1/4" jack capable of handling a wide variety of signal levels up to 2.0v RMS.

Channel Switching

You can switch from channel A (clean) to channel B (overdrive) in two ways. One is by using the A/B button on the front panel, the other being the footswitch. (described later)

Channel A

Channel A offers a new fully produced clean sound for rhythm work or for clean lead applications. This channel can be used for anything from cool jazz to smokin' blues.

Compander on/off

The compander on the clean channel is a pre-set* effect that levels out the signal. It does this by cutting the initial signal and boosting the signal as it decays; resulting in a clean sustain for a "bluesy" sound.

Gain on/off

The gain switch is also pre-set.* With the switch on, the signal is given a boost which puts an edge on the sound without totally overdriving it. This effect used in conjunction with the compander sounds great for single note soloing and chord melodies.

Volume

This knob controls the total output for the clean channel A from off to full power.

*The pre-set effects have been factory adjusted to common settings. These can be internally adjusted by a technician at Owner's expense.

Channel B

Channel B represents 15 years of research and development for a warm solid state distortion. This channel, with no effects or gain on is the backbone for the supreme rock sound.

Gain on/off

This switch is also a pre-set control. It gives the option of two gain levels, (as with channel A). With the gain in on channel B, the signal is boosted to a very high level producing an infinite sustain. Used with care, this effect can offer any squawk, scream or crunch needed for contemporary high-energy rock & roll.

Volume

This knob controls the total output for the overdrive channel B from off to full power.

4 band EQ

1. The first knob from the left is an active treble control operating at 8.0 kilohertz. It adds high-end and brightness to your sound.
2. The second knob is an active high mid-range control operating at 2.0 kilohertz. This control adds punch to your sound.
3. The third knob is an active low mid-range control operating at 500 hertz. This control adds to the meat or body of your sound.
4. The last EQ knob is an active bass control operating at 120 hertz. This controls the bottom end of your sound. The Boom!

Stereo Effects

The next two switches make up the stereo effects section. The first one being the pre-set stereo Echo. This effect acts like an electronic reverb but using an IC chip as opposed to a spring unit to produce a full stereo reverberation.

The second switch is a pre-set stereo Chorus effect. This effect, also using a high technology IC chip, gives a full stereo enhancement of your sound in total stereo voicing.

Footswitch

The footswitch jack is a standard 1/4" stereo jack. With the footswitch you can change channels (from A to B) and turn the stereo effects on and off. (see accessories)

Phones

The phones jack is also a standard 1/4" stereo jack. It delivers a balanced stereo signal for use with high impedance head phones, (600 ohm or greater). Plugging into the phones jack disconnects all speakers.

Power Switch

The power switch on the 250ML/212SCL is located on the rear panel above the fuse holder. On the 250RL the switch is on the front panel lower right.

Power Cord

The power cord is detachable and plugs into a socket located on the rear panel. If a replacement cord is used or needed it should be UL rated at 10amp, 125v; or if using 240v, the cord should be UL rated at 5amp, 240v.

Direct Out

This is an electronically balanced mono output that will put 500 mv RMS into a 600 ohm load. It comes in after the effects loop and is located on the rear panel. This output shuts off when the head phone jack is used.

Effects Loop

The effects loop, located on the rear panel is provided for the insertion of effects. It is post EQ and pre internal effects. Using standard guitar cords, connect the effects input to the send; the effects output to the return. The level is 5v for full power out.

Extension Speakers (not on 212SCL)

The following are instructions for connecting your Stereo Effects Series product to different speaker loads. Do not use any other than the recommended loads per side.

CAUTION: Under no circumstances should the two speaker jacks be connected together in any way!

250ML

External speakers for the 250ML must be rated 16ohm minimum per side. We recommend the 212EGS (stereo cab.) or two 4x12" 16ohm cabinets.

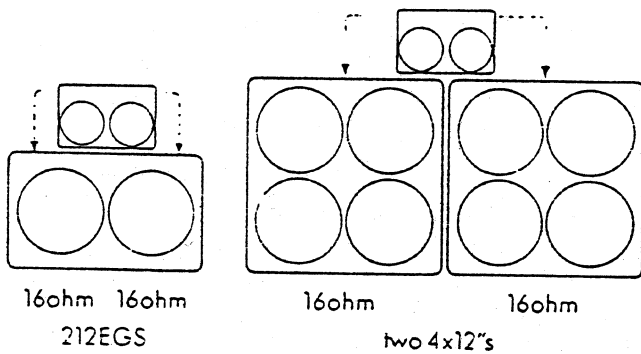

250RL

External speakers for the 250RL must be rated at 8ohms or more (16ohms OK). We recommend the 212EGS (stereo cab.) or two 8ohm cabinets (212EG).

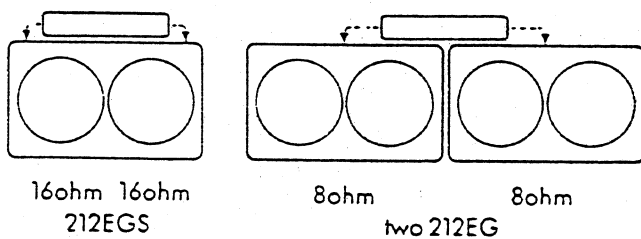

Aux. In/Stereo Out

This unique jack, located on the rear panel, can be used as either an auxiliary stereo input or as a stereo line out. When used as an auxiliary stereo input you can play along with music from records, tapes or a stereo receiver. Using the aux. out or phone jack of your music source to the aux. stereo input of your amplifier.

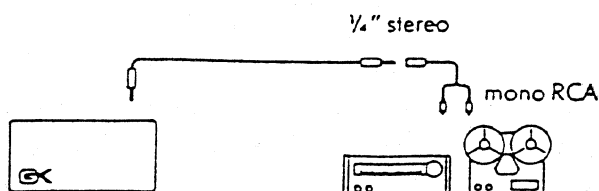

When used as a stereo output, this jack can be used to record or to play live through a mixer board. For this the same stereo cord is used along with the 1/4" Y adapter. To do this you need to connect the stereo out of your amp to two channels of the mixer board panning them all the way left and all the way right accordingly.

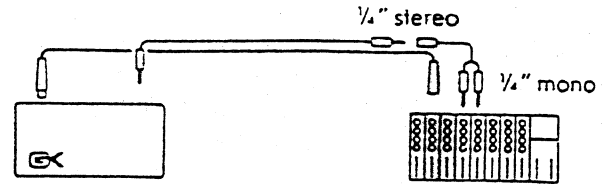

This jack can also be used to play along with another stereo amplifier (250ML/RL/212SCL). To do this you must go from the phone jack of one amp to the auxiliary stereo in/stereo out jack of the other. For the two headphones to work out of one jack, a stereo phones "Y" adapter is needed.

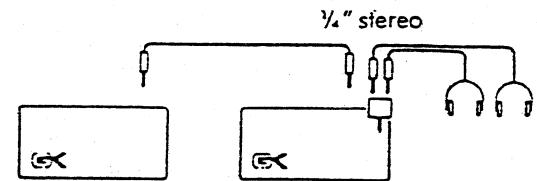

Fuse

Located on the rear panel. Never operate this amplifier with any other than the recommended fuse.

115v operation — type TSC2A
240v operation — type TSC1A

Maintenance

Your new amplifier is rugged. It was built to give you a lifetime of trouble free operation. If it is operated with care, your only maintenance problems should be cleaning. We recommend a soft damp cloth and mild soap for cleaning the outside surfaces. A road case is advised for further protection from travel and handling.

250 ML MIC STAND BRACKET

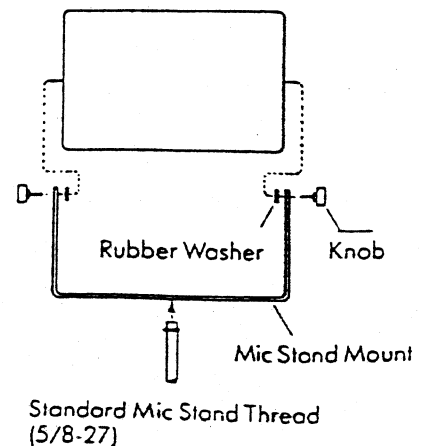

250ML: Functional Block Diagram

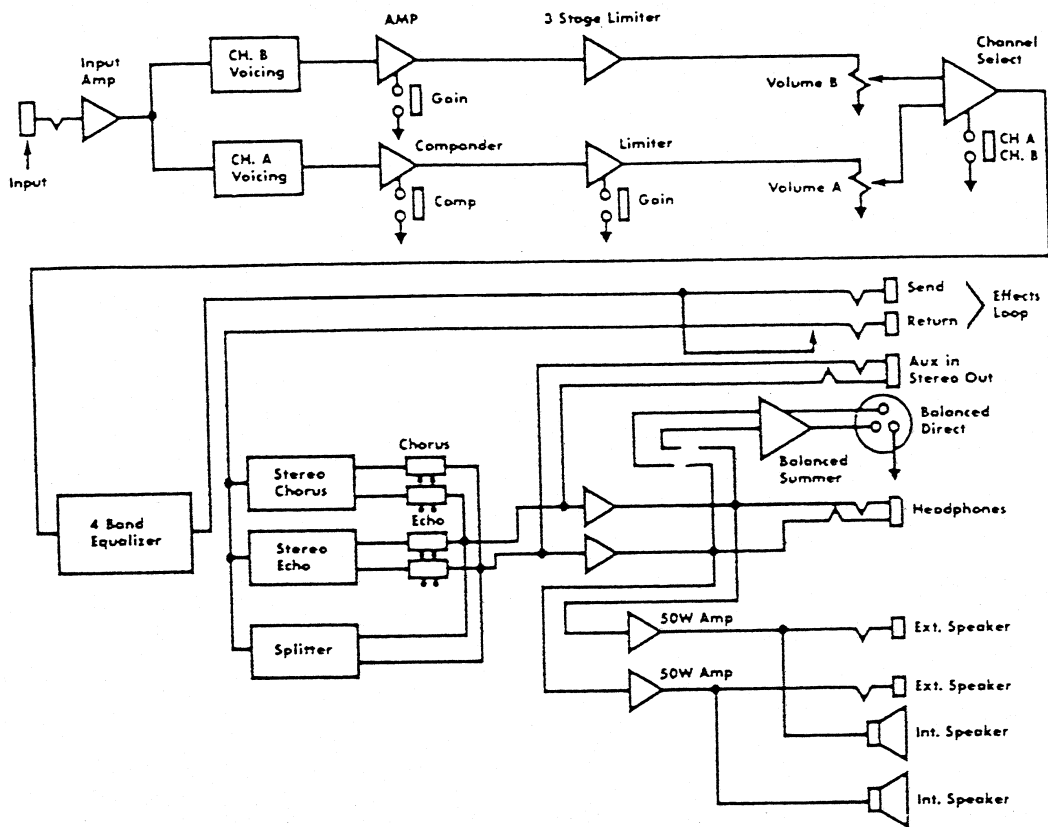

Specifications

Sensitivity
 Channel A - 35mV
 Channel B - .5mV

Power
 50 Watts/channel

Effects Send
 Level - 5V_{RMS}, 10K Ω

Effects Return
 Level - 5V_{RMS}, 22K Ω

Direct (Bal)
 Level - 175 mV_{RMS}, 600 Ω

Stereo Aux Out
 Level - 200 mV_{RMS} 220K Ω

Stereo Aux. In
 Level - 2.5V_{RMS} 33K Ω

Extension Speakers - 250ML
 16 Ω min. per channel

Speakers - 250RL
 8 Ω min. per channel

	250ML	212SCL	250RL
Weight	22 lbs.	56 lbs.	10 lbs.
Dimensions	13.75" x 9" x 6"	26.75" x 16.5" x 12"	17.5" x 3.5" x 6.75"
Speakers	2 x 6.5"	2 x 12"	N/A
Speaker Type	Pyle	Celestion	N/A

Stereo Effects Series Accessories
 - 250ML Mic Stand Bracket
 - Footswitch

250ML/RL T/O PROCEDURE

Rev. 1: 2/1/88

- 1) Inspect board.
- 2) Observe the following:
 - A) Variac at 0
 - B) No load
 - C) Switches out
 - D) Speaker load on
 - E) Scope on A
 - F) Tones on 5
 - G) Volumes on 0
- 3) Slowly adjust variac to 20 Vrms. Reg. Supplies $-3.0V + or - .5V$ $3.6 V + or - .5V$
- 4) Slowly continue adjusting variac to 60 Vrms. Output will go $-3V$ then $+1V$ and then settle at 0 between 20-30 Vrms.
Reg. Supplies $+ or -14.5V + or - 1 V$.
- 5) Adjust to 120 Vrms. Supplies $+ or - 43 V + or -1V$.
- 6) Turn speaker load off and bias.
Adjust R114 to get a 5mV bias across R106 and R123.
Adjust R147 to get a 5mV bias across R139 and R157.
- 7) Set the following:
 - A) Loads A and B on 8 ohms
 - B) Sine input (400 Hz 160 Vrms) $- 16.0$ dB
- 8) Full power and current limiter test.
 - A) Slowly turn up volume A until output clips Output should clip evenly and $=18$ Vrms
At clip. Continue to turn up volume. Output should slam into the rails. Check R and L amp.
 - B) Change to 4 ohm loads.
 - C) Output should be clean and $= 14$ Vrms.
- 9) Turn loads off.
- 10) Adjust vol. A just to where output clips and measure balance out $= .4Vrms$ at pins 2 ,3.
- 11) Set the following:
 - A) Input (400 Hz 500 mVrms) $-6.0dBs$.
 - B) Compander engaged.
- 12) Adjust compander.
 - A) Adjust R18 to 4.4 Vrms at U1 P7.
 - B) Drop input 10dB. Output should attenuate then swell up.
 - C) Raise input 10dB. Output should expand then swell down.
 - D) Compander off.
- 13) Set input to (400 Hz 500mVrms)- 6.0 dBs.
- 14) Adjust chan. A overdrive. Adjust R14 to get $.84$ mVrms at U3 P1.
- 15) Change the following:
 - A) Input (400Hz. 500mVrms)- 6.0 dBs.
 - B) Change to chan. B and engage gain B switch.
- 16) Adjust chan. B overdrive.
 - A) Put scope probe on U6 P7 and adjust R36 for 20 Vp-p square wave.
 - B) Put probe on U10 P1 and adjust R37 for a 10Vp-p square wave.
 - C) Reduce input to 5 mVrms ($-46dB$)
 - D) Keep probe at U10 P1 and adjust R35 for 6Vp-p sine wave.

- D) (Contd.) You may double check by returning to 500 mVrms at input and making Sure U6 P1 is below 20 Vp-p.
- 17) Test tone controls. Set tone controls to 10 and vol @ .25. Compare output to tone figures.
- 18) Echo test.
 - A) Engage echo switch.
 - B) Compare output to echo figures for R and L amp.
 - C) Echo off.
- 19) Chorus test.
 - A) Engage chorus switch.
 - B) Compare output to chorus figure for R and L amp.
- 20) Set the following:
 - A) Switch to a square input (200 Hz. 20 mVp-p) – 44dBs.
 - B) Set volume at 5
 - C) Gain switches off.
- 21) Compare output to Chan. B square figure.
- 22) Switch to Chan. A and compare Chan. A square figure.
- 23) Plug input signal into return jack to make sure it works.
- 24) Disconnect input signal and speaker on.
- 25) Noise and tap test- Chan. A:
 - Noise < or = 1 Vrms. Comp on, gain off, vol. 10, tones 10, effects off
 - 500 Vrms. Comp off.
- 26) Noise and tap test- Chan. B:
 - Noise < or = 250 mVrms Vol. 10, tone 10, gain off.
 - Noise should be clean w/o popping or crackling. Tap brain on bench a few times to make sure nothing fails.
- 27) Echo pop test.
 - A) Chan. B
 - B) Echo on.
 - C) Vol. 5.
 - D) Quickly pop in and out input signal. Output should echo w/o distortion.

"Beefing" a 250ML or 250RL

Important Notes:

The Trim Pots are sensitive and will take very little movement to make a difference. We suggest that you start with the two pots on the left (see diagram) first, then adjust the pot on the right. It will take some time to get to the desired sound. You should also be aware that once the pots have been turned, getting back to their original setting may vary slightly from your original markings.

Caution:

Please take all normal precautions. There is danger of electric shock when cover is removed!

In order to get more distortion (gain or overdrive) from your 250ML or 250RL, please follow the simple instructions below:

1. Turn off amplifier and remove power cord.
2. Remove top cover screws and remove top cover.
3. Find the three white "Trim Pots" near the "B" Channel Volume Knob.
4. Mark where the pots are currently set (as a reference).
5. Make slight adjustments to pots by turning the "pointer", not the entire pot.
6. Plug in amp and with low volume check for sound quality. Turn pot counter-clockwise for more gain, clockwise for less gain.
7. Repeat steps 5 and 6, but leave original markings on pots.
8. Replace cover.

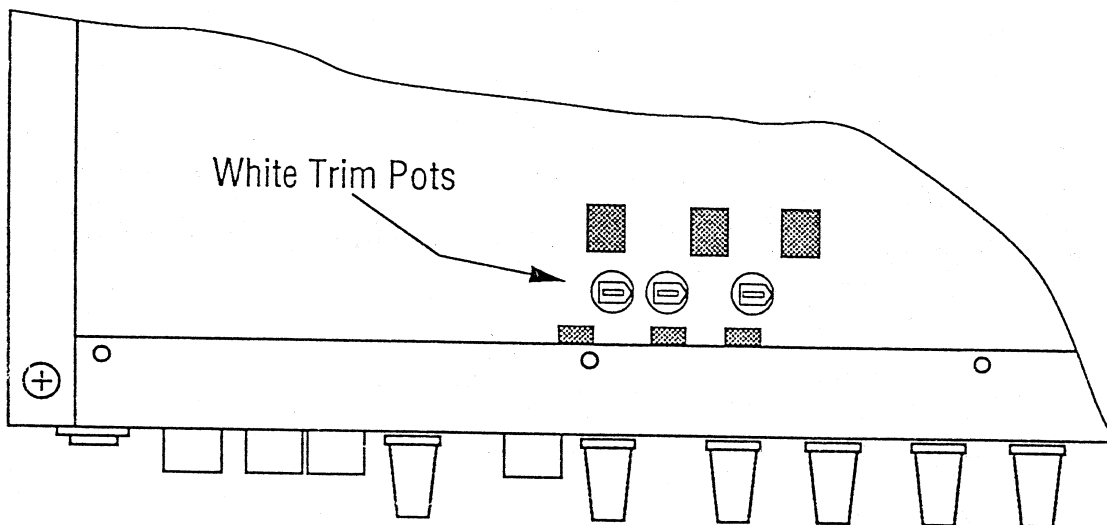

Viewing From Top with Cover Removed
(250ML or 250RL only)

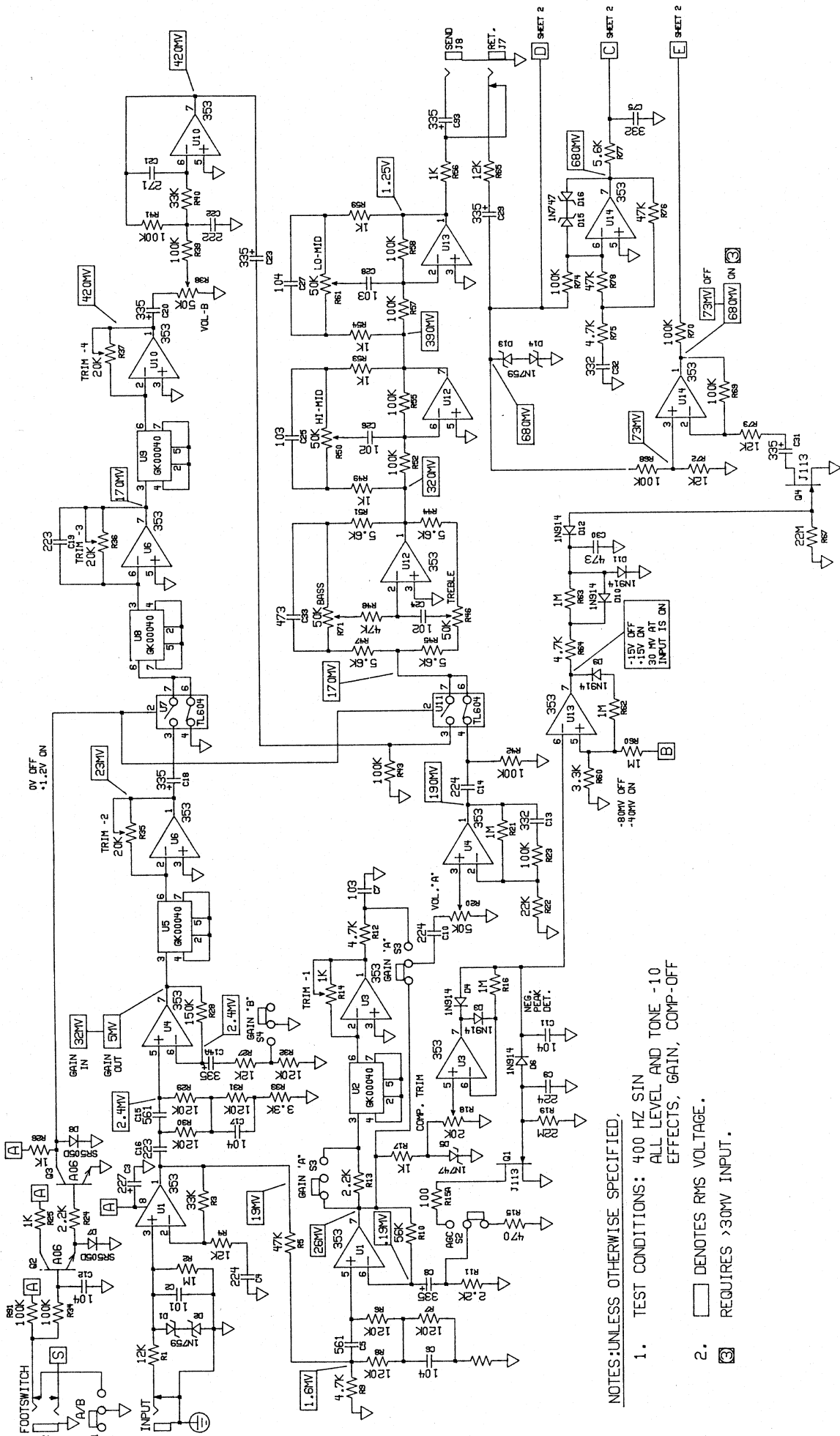

NOTES: UNLESS OTHERWISE SPECIFIED,

1. TEST CONDITIONS: 400 HZ SIN
ALL LEVEL AND TONE -10
EFFECTS, GAIN, COMP-OFF
2. DENOTES RMS VOLTAGE.
3. REQUIRES >30MV INPUT.

PCO#	DATE	FIRST SN	PCO#	DATE	FIRST SN	PCO#	DATE	FIRST SN

GALLIEN-KRUEGER		MODEL #:	DATE:	DESCRIPTION:
		250ML	10-17-89	PREAMP
		DESIGNED BY:	BOARD #:	PCO#-DATE:
		60049A		FROM SN: TO SN:
SCHEMATIC PG: 1 OF: 3				

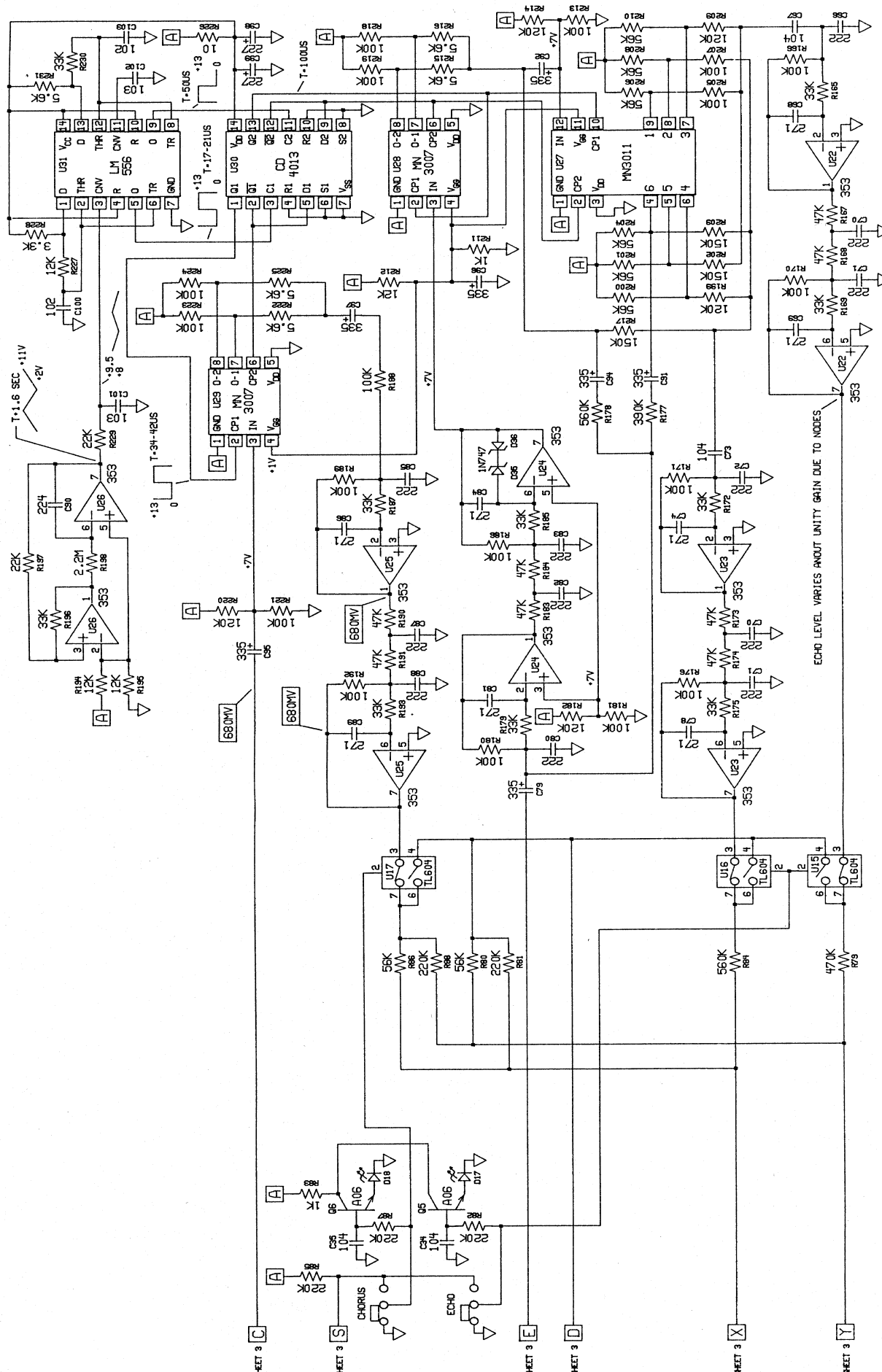

MODEL #: 250ML	DATE: 10-17-89	DESCRIPTION: CHORUS & ECHO
DESIGNED BY: GALLIEN-KRUEGER	BOARD #: 60049A	PCO#-DATE: FROM SN: TO SN:
SCHEMATIC PG: 2 OF 3		

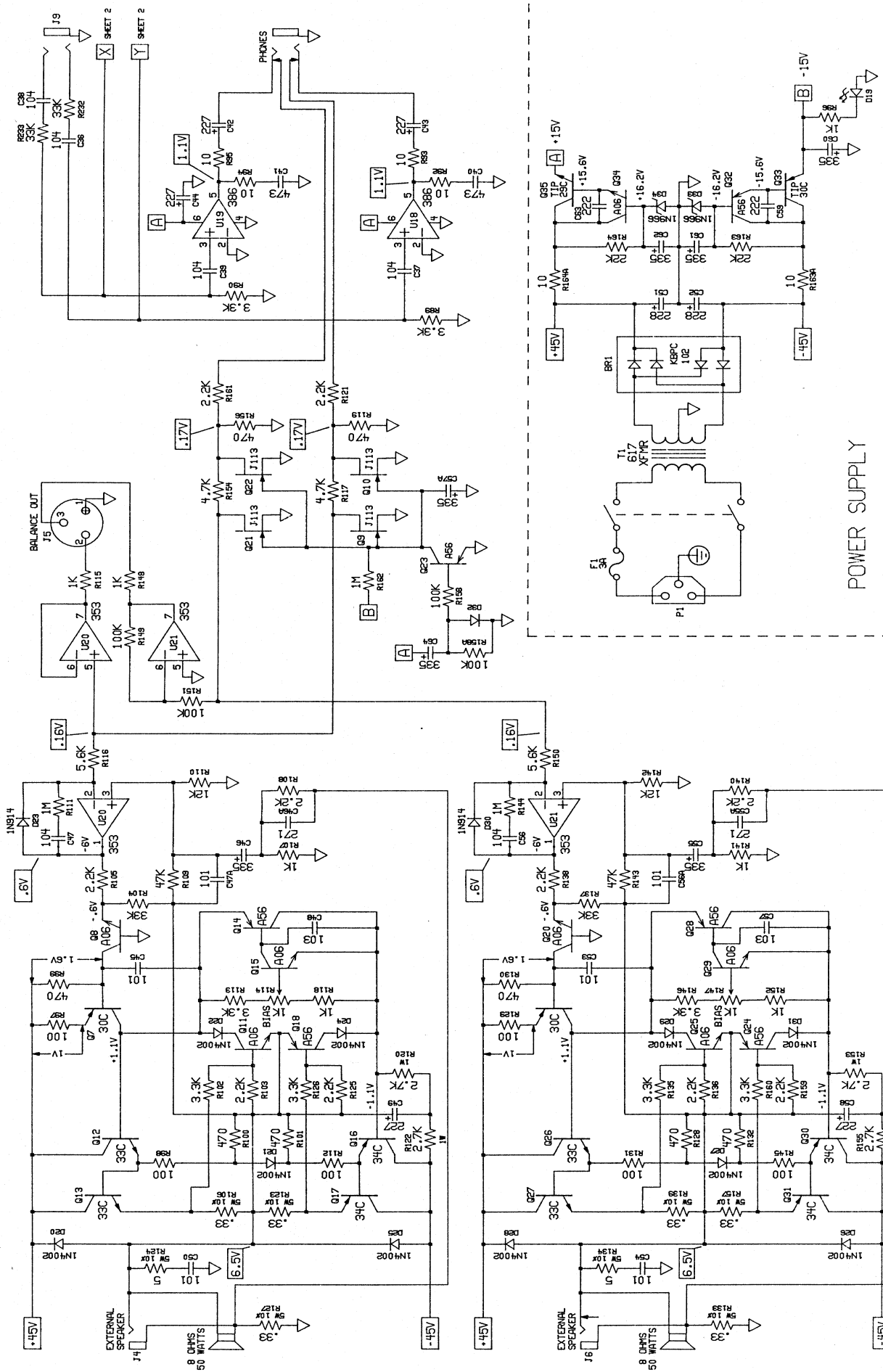

POWER SUPPLY

GALLIEN-KRUEGER	MODEL #:	DATE:	DESCRIPTION: POWER AMP,
	250ML	10-20-89	POWER SUPPLY & OUTPUTS
SCHMATIC PG: 3 OF: 3	DESIGNED BY:	BOARD #:	PCO#-DATE:
		60049A	FROM SN: TO SN:

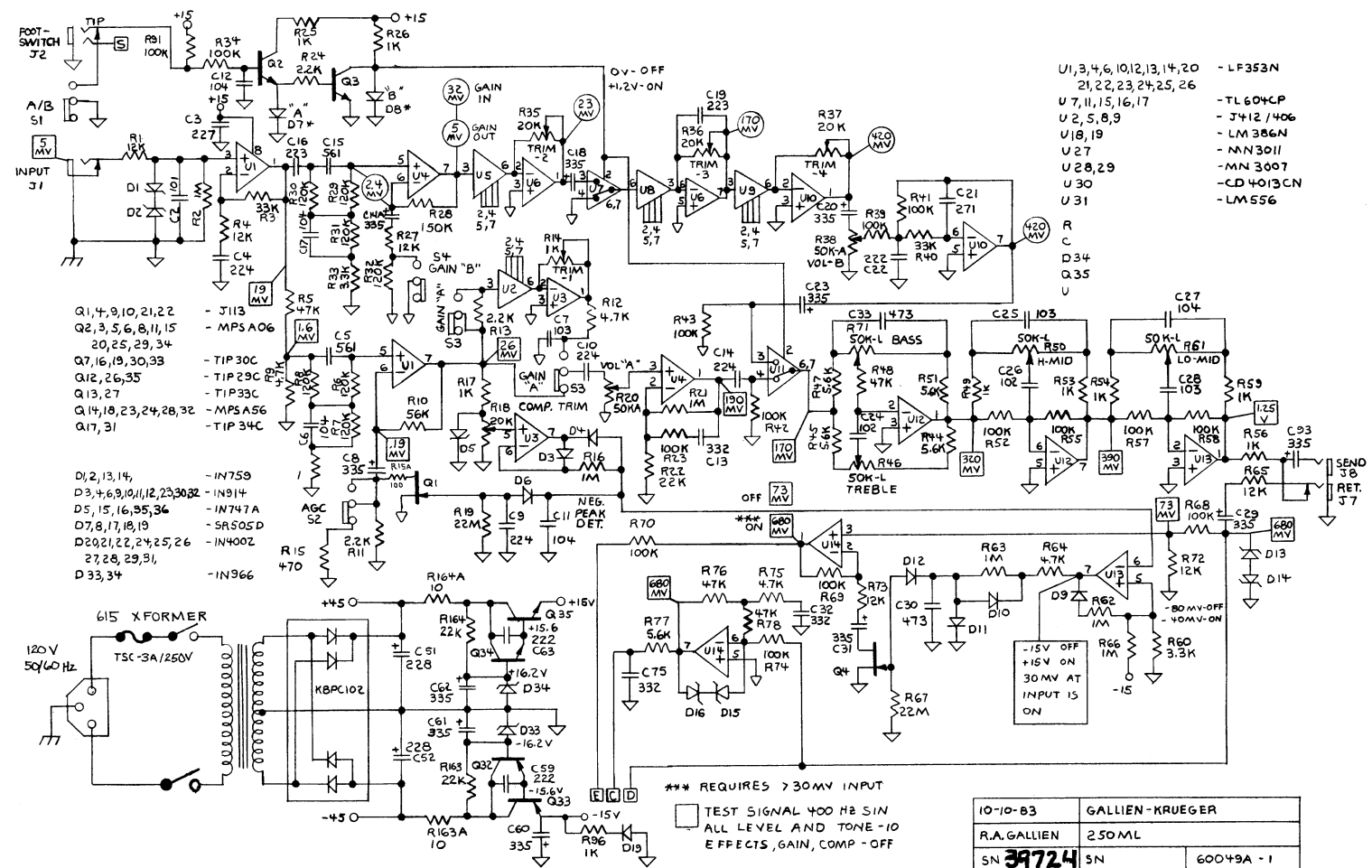
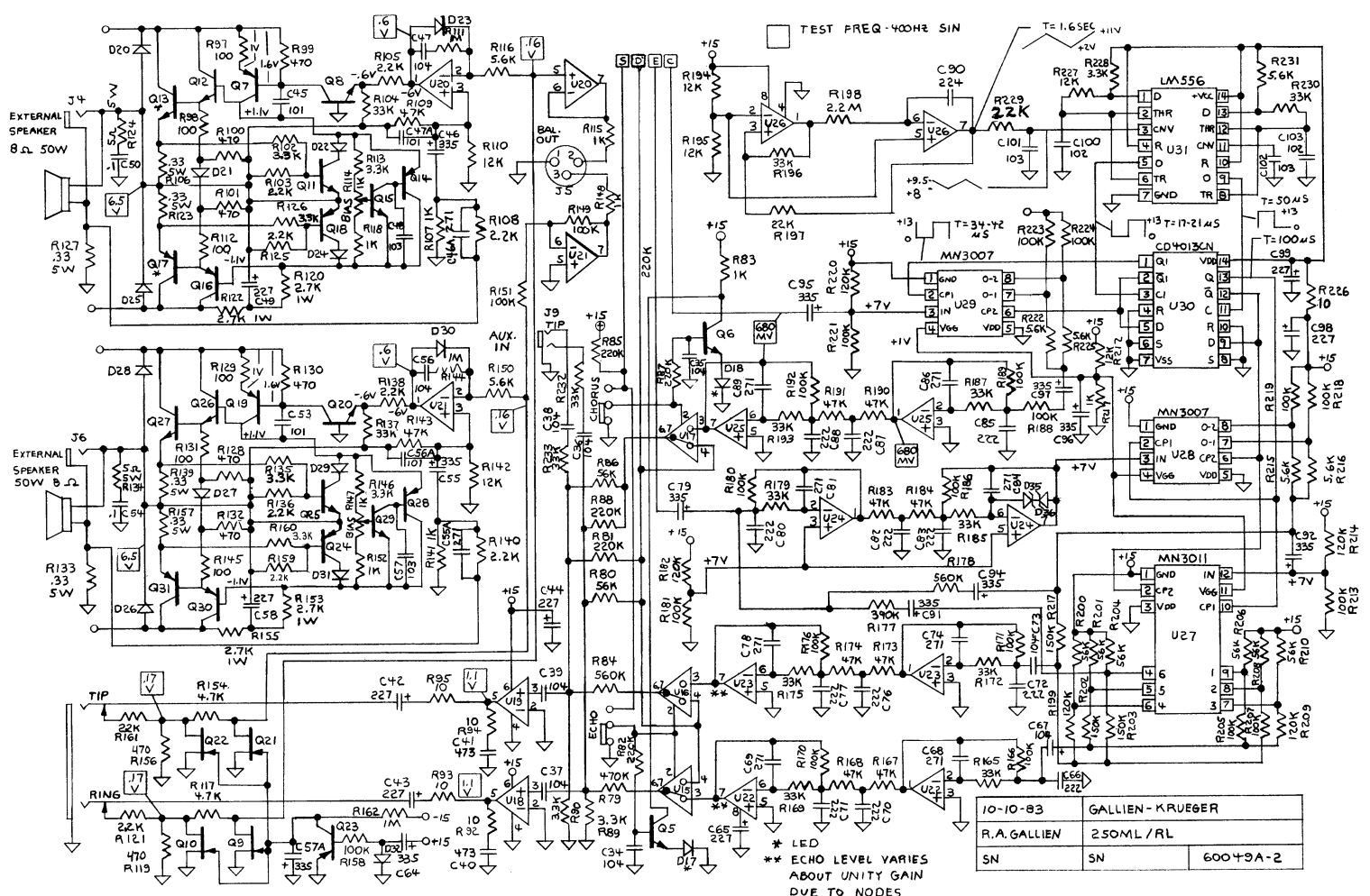

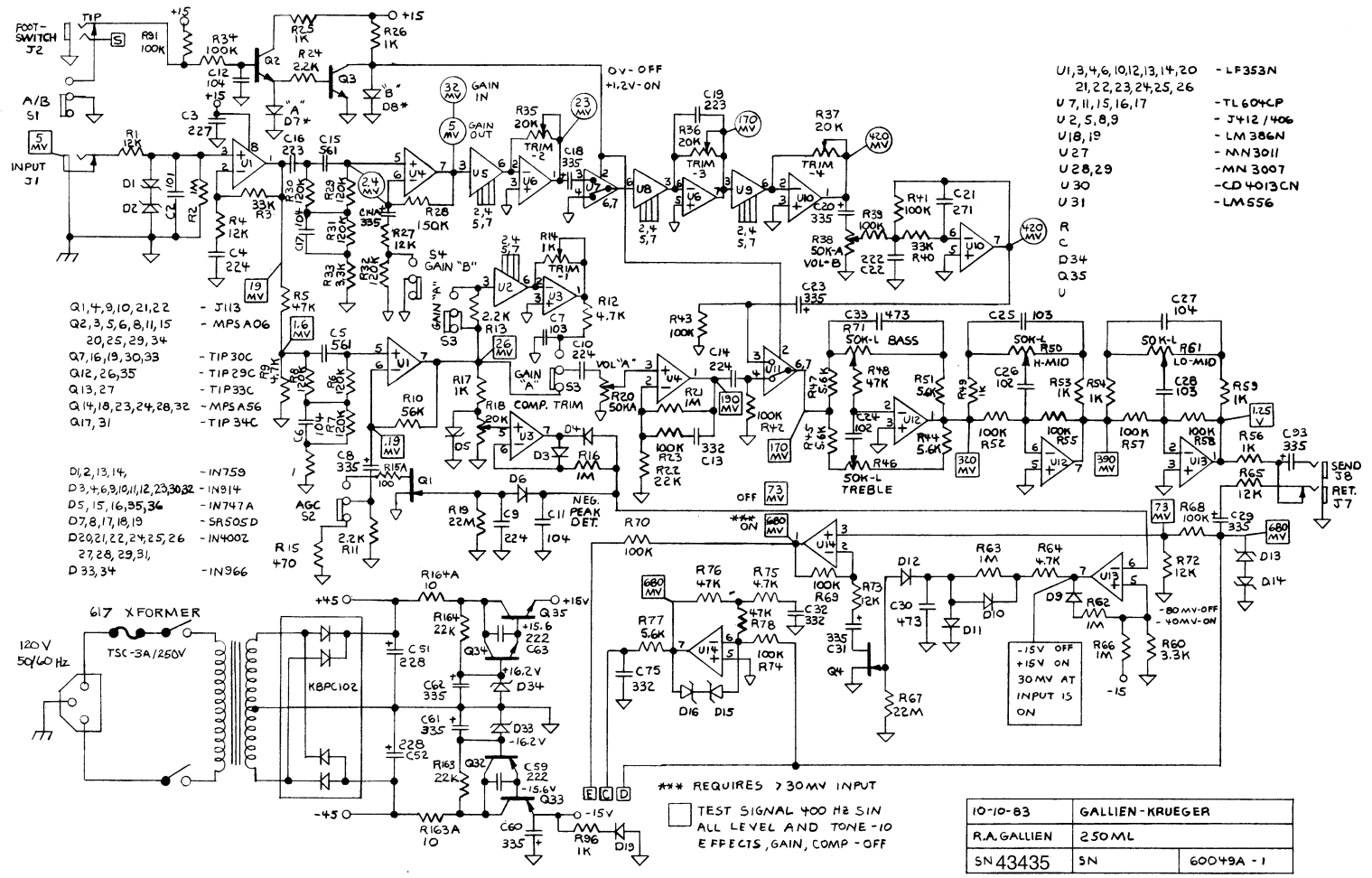
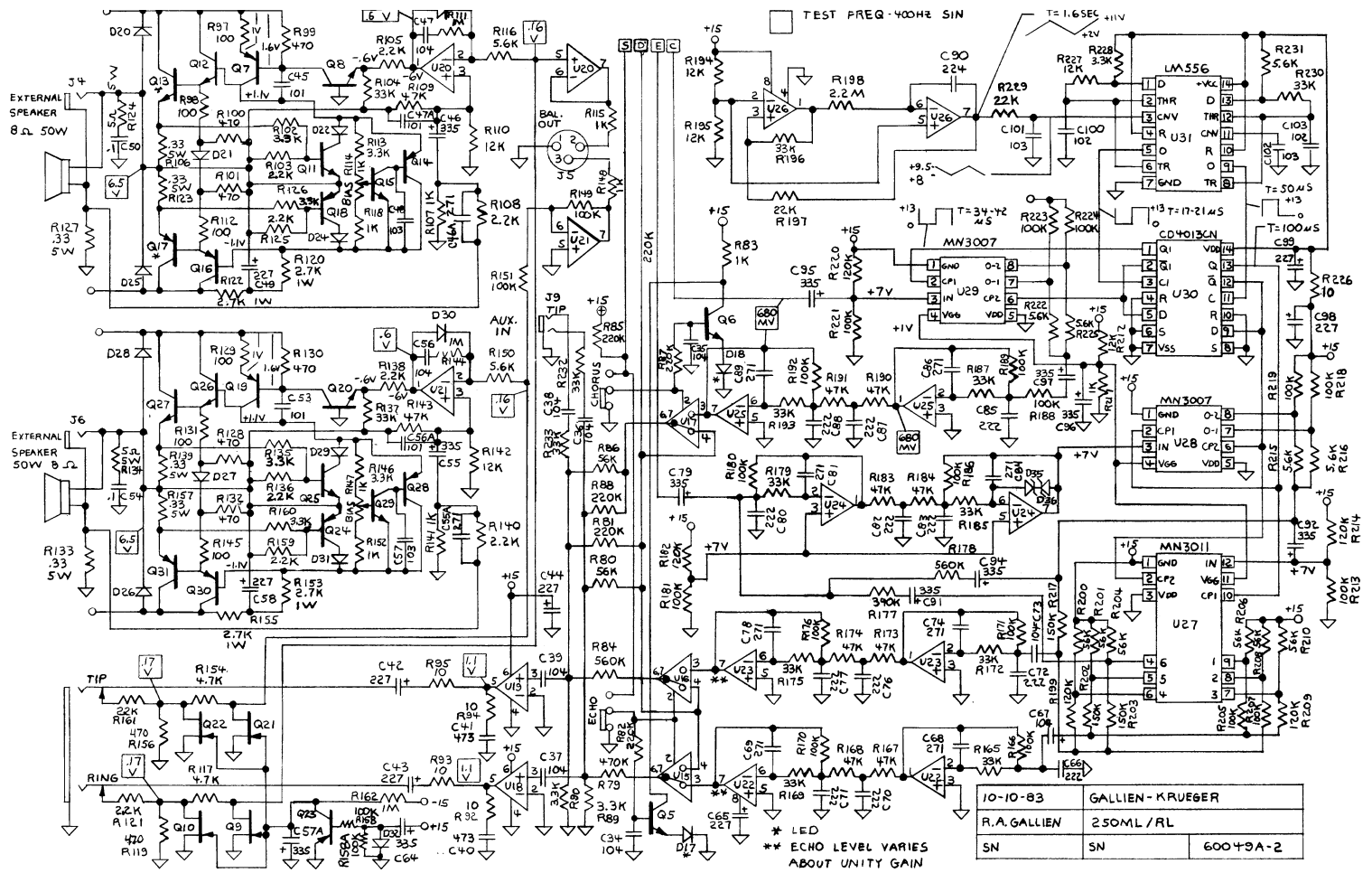

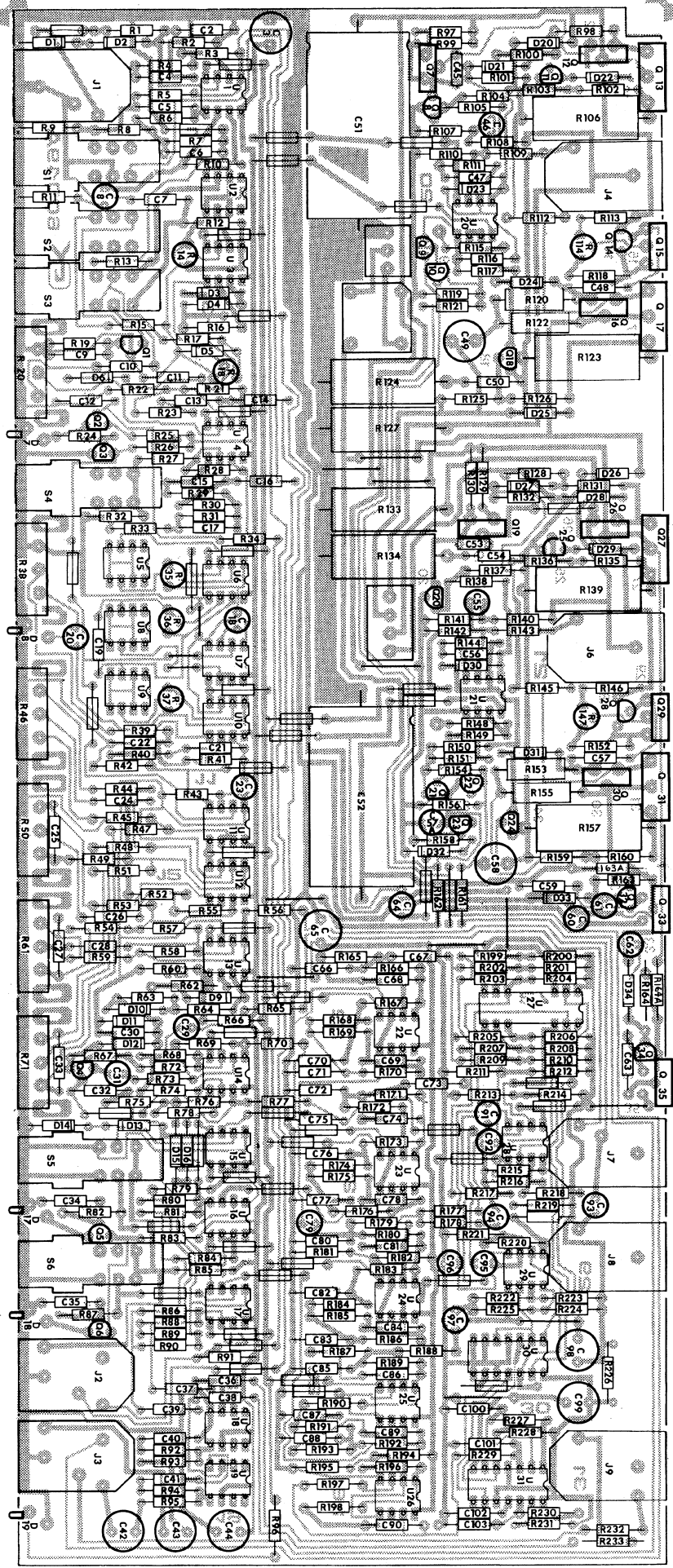

12/83	GALIEN - KRUEGER INC.
R.A. GALIEN	ASSY. DWG. - 60049A

250ML INDENTED BILL OF MATERIALS

NOTE: Level 1 refers to main assmby parts.
 Level 2 refers to board level components.
 Main assembly numbers are in bold face, while commonly
 needed parts are italicized.

LVL	PART#	DESCRIPTION	QTY	REF. DESIG.
1	010-0012-0	MPSA06 NPN 80V 500MA TO-92	2	
1	011-0023-0	TIP29C NPN 100V 1A TO-220 FP	1	
1	011-1035-0	TIP30C PNP 100V 1A TO-220	1	
1	012-0084-0	TIP 33CFP NPN 100V 10A TO218	2	Q13,27
1	012-1085-0	TIP 34CFP,PNP,100V,10A,TO-218,PECOR	2	Q17,31
1	025-0116-0	RED LED,1.5MCD,120 DEG,T-1	5	
1	080-0062-0	TRANSFORMER,80W,120V,Z=4	1	
1	082-0047-0	SPEAKER,6.5",80W,Z=16 PYLE-LEAD	2	
1	090-0005-0	SWITCH,ROCKER,DPDT,4A,QUICK-TERM	2	
1	091-0003-0	FUSE, 3A,125V,1/4X1 1/4,SLB	1	
2	799-TEST-0	TRY OUT	0	
1	092-0045-0	XLR,MALE,X70101 LUGS	1	
1	093-0014-0	RECEPTICAL AC,Q-TERM	1	
1	093-0032-0	HOUSING,3X.156,FEMALE 22GA,LOCK	1	
1	093-0035-0	HOUSING,4X.156,FEMALE 22GA,LOCK	1	
1	094-0013-0	HOLDER,FUSE,1/4 X 1 1/4,Q-TERM	1	
1	094-0019-0	SOLDER LUG,#6	1	
1	095-0005-0	POWER CORD,117V PLUG,DETACH	1	
1	100-0012-0	GROMIT,3/16 X.100	1	
1	100-0016-0	LOGO,3 INCH,CAST	1	
1	100-0030-0	BUTTON,RECT BLACK CAP - PUSH SWITCH	6	
1	100-0037-0	HEAT CLIP,TO-98	2	
1	100-0042-0	HANDLE,RUBBER,6.5"	1	
1	100-0057-0	KNOB BODY 18 SPLINE SHAFT	6	
1	100-0062-0	KNOB CAP GRAY,FOR 100-0057	6	
1	100-0065-0	CAP FOR 6.5" HANDLE "BLACK"	2	
1	100-0076-0	FOOT,RUBBER,ROUND,5/8DIA. X 5/8"	4	
1	111-0061-0	BOLT 4-40 3/8 PHP CAD	5	
1	111-0081-0	BOLT 4-40 1/2 PHP CAD	8	

LVL	PART#	DESCRIPTION	QTY	REF. DESIG.
1	111-3041-0	SCREW 4AB 1/4 PHP CAD	2	
1	111-6001-0	NUT 4-40 KEP SMALL	7	
1	111-6011-0	NUT 4-40 HEX SMALL CAD	6	
1	111-7011-0	WASHER #4 SPLIT	6	
1	112-0051-0	BOLT 6-32 5/16 PHP CAD	4	
1	112-1040-0	BOLT 6-32 1/4 FHP 82^ B.O.	4	
1	112-1050-0	BOLT 6-32 5/16 FHP 82^ B.O.	11	
1	112-1100-0	BOLT 6-32 5/8 FHP 82^ B.O.	8	
1	112-4080-0	SCREW 6AB 1/2 FHP 82^ B.O.	27	
1	112-4081-0	SCREW 6AB 1/2 FHP 82^ CAD	1	
1	112-6001-0	NUT 6-32 KEP LARG SIZE CAD	8	
1	112-7001-0	WASHER #6 FLAT CAD	12	
1	113-0080-0	BOLT 8-32 1/2 PHP B.O.	4	
1	113-6011-0	NUT 8-32 KEP CAD	4	
1	114-0080-0	BOLT 10-32 1/2 PHP B.O.	2	
1	115-7005-0	WASHER 3/8 FIBRE FLAT	2	
1	115-7021-0	WASHER 3/8 INTERNAL CAD	6	
1	132-0034-B	250ML FRONT PANEL	1	
2	112-6016-0	NUT 6-32 CAPTIVE	7	
2	120-0007-0	ALUM .063	54	
1	132-0349-A	200MK/MV TOP COVER	1	
2	120-0005-0	ALUM .100	98	
1	132-0379-B	200MV RIGHT SIDE	1	
2	114-6046-0	NUT 10-32 CAPTIVE	1	
2	120-0005-0	ALUM .100	96	
1	132-0380-B	200MV LEFT SIDE	1	
2	114-6046-0	NUT 10-32 CAPTIVE	1	
2	120-0005-0	ALUM .100	96	
1	132-0381-B	200MV GRILL	1	
2	120-0004-0	STEEL,16GA,PERF,4'X10'X.060	144	
1	132-0382-B	250ML REAR PANEL	1	
2	112-6016-0	NUT 6-32 CAPTIVE	10	
2	120-0005-0	ALUM .100	42	

LVL	PART#	DESCRIPTION	QTY	REF. DESIG.
1	132-0389-F	250ML BACK SERIES 2,1	1	
2	120-0005-0	ALUM .100	288	
1	132-0391-D	250ML (II) BAFFLE, PYLE	1	
2	120-0005-0	ALUM .100	288	
1	160-0003-0	MANUAL,250ML-RL	1	
1	202-0019-0	250ML II WIRE KIT	1	
1	206-0049-A	250ML AMP	1	
2	001-0001-0	MN3011 MULTI-TAP BBD	1	U27
2	001-0006-0	MN3007 1024 STAGE BBD	2	U28,29
2	001-1030-0	LF353N DUAL JFET OP AMP	15	U1,3,4,6,10,12,13,14,20,21,22,23,24,25,26
2	001-1038-0	LM386 LOW VOLTAGE POWER AMP	2	U18,19
2	001-2009-0	LM556CN DUAL TIMER	1	U31
2	001-3028-0	TL604 DUAL COMP ANALOG SWITCH	5	U7,11,15,16,17
2	002-0034-0	CD4013 DUAL D FLIP-FLOP	1	U30
2	010-0012-0	MPSA06 NPN 80V 500MA TO-92	9	Q2,3,5,6,8,11,15,20,25,29,34
2	010-1013-0	MPSA56 PNP 80V 500MA TO-92	6	Q15,18,22,23,24,28
2	010-2010-0	J113 N-JFET 35V 2MA TO-92	6	Q1,4,9,10,21,22
2	010-2040-0	J406 DUAL N-CH JFET 8PIN DIP	4	U2,5,8,9
2	011-0023-0	TIP29C NPN 100V 1A TO-220 FP	2	Q26,35
2	011-1035-0	TIP30C PNP 100V 1A TO-220	4	Q7,19,31,33
2	020-0036-0	1N747A,ZENER,3.6V,5%,400MW,DO-35	5	D5,15,16,35,36
2	020-0120-0	1N759A,ZENER,12V,5%,400MW,DO-35	4	D1,2,13,14
2	020-0160-0	1N966B,ZENER,16V,5%,400MW,DO-35	2	D33,34
2	020-1103-0	1N914 ,RECT-FAST,200MA,100V,4NS,DO-35	10	D3,4,6,9,10,11,12,23,30,32
2	020-2105-0	1N4002,RECT,1A,150V,DO-41	10	D20,21,22,25,26,27,28,29,31
2	023-0109-0	KBPC-102 BRIDGE RECT 3A,200V,C219K	1	BR1
2	030-0223-0	CAP,CERAMIC AXIAL,223,30%,16V	2	C16,19
2	030-1103-0	CAP,CERAMIC AXIAL,103,30%,25V	7	C7,25,28,48,57,101,102
2	030-2101-0	CAP,CERAMIC AXIAL,101,5%,50V	1	C2
2	030-2102-0	CAP,CERAMIC AXIAL,102,10%,50V	4	C24,28,100,109
2	030-2104-0	CAP,CERAMIC AXIAL,104,10%,50V,XR7,.3"	17	C6,11,12,17,27,34,35,36,37,38,39,47,56,67,73
2	030-2222-0	CAP,CERAMIC AXIAL,222,10%,50V	15	C22,59,63,70,71,72,80,81,82,83,85,87,88

LVL	PART#	DESCRIPTION	QTY	REF. DESIG.
2	030-2224-0	CAP,CERAMIC AXIAL,224,20%,50V,XR7	5	C4,9,10,14,90
2	030-2271-0	CAP,CERAMIC AXIAL,271,10%,50V	11	C21,55A,66,68,69,78,81,84,86,89
2	030-2332-0	CAP,CERAMIC AXIAL,332,10%,50V	3	C13,32,75
2	030-2473-0	CAP,CERAMIC AXIAL XR7,473,10%,50V	4	C30,33,40,41
2	030-2561-0	CAP,CERAMIC AXIAL,561,10%,50V	2	C5,15
2	031-1227-0	CAP,ELECTROLYTIC RADIAL,227,-10%+50%,25V	7	C3,42,43,44,49,58,65
2	031-2227-0	CAP,ELECTROLYTIC RADIAL,227,-10%+50%,50V	2	C51,52
2	031-2335-0	CAP,ELECTROLYTIC RADIAL,335,20%,50V	22	C8,14A,18,20,23,29,31,46,55,57A,60,61,62,64,79,91,92,93,94,95,96,97
2	032-4104-0	CAP,METALIZED POLYESTER,104,10%,100V	2	
2	034-4101-0	CAP,CERAMIC DISK,101,10%,100V	4	
2	038-2228-0	CAP,ELECTROLYTIC AXIAL,228,20%,50V	2	
2	051-0100-0	RES,CARBON FILM,1 OHM,1/4W,5%	2	R1,R2
2	051-1001-0	RES,CARBON FILM,100 OHM,1/4W,5%	7	R15A,29,97,98,112,131,145
2	051-1002-0	RES,CARBON FILM,1K OHM,1/4W,5%	17	R17,25,26,49,53,54,56,59,83,107,115,118,141,148,152,211
2	051-1004-0	RES,CARBON FILM,100K OHM,1/4W,5%	37	R23,34,39,41,42,43,52,55,58,68,69,70,74,149,151,158,158A,166,170,171,176,180,181,188,189,192,196,205,207,213,219,221,223,224
2	051-1005-0	RES,CARBON FILM,1M OHM,1/4W,5%	9	R2,16,21,60,62,63,111,144,162
2	051-1203-0	RES,CARBON FILM,12K OHM,1/4W,5%	12	R1,4,32,65,72,73,110,142,194,195,212,227
2	051-1204-0	RES,CARBON FILM,120K OHM,1/4W,5%	12	R6,7,8,29,30,31,32,182,199,209,214,220
2	051-1504-0	RES,CARBON FILM,150K OHM,1/4W,5%	4	R28,202,209,217
2	051-2202-0	RES,CARBON FILM,2.2K OHM,1/4W,5%	11	R11,13,24,103,105,108,121,125,136,138,140,159,161
2	051-2203-0	RES,CARBON FILM,22K OHM,1/4W,5%	5	R22,163,164,197,229
2	051-2204-0	RES,CARBON FILM,220K OHM,1/4W,5%	5	R81,82,85,87,88
2	051-2205-0	RES,CARBON FILM,2.2M OHM,1/4W,5%	1	R198
2	051-2206-0	RES,CARBON FILM,22M OHM,1/4W,5%	2	R19,67
2	051-3302-0	RES,CARBON FILM,3.3K OHM,1/4W,5%	4	R33,60,89,90,102,119,126,135,146,160,228
2	051-3303-0	RES,CARBON FILM,33K OHM,1/4W,5%	16	R3,40,104,137,165,172,175,179,187,193,196,230,232,233
2	051-3904-0	RES,CARBON FILM,390K OHM,1/4W,5%	1	R177
2	051-4701-0	RES,CARBON FILM,470 OHM,1/4W,5%	7	R15,99,100,101,119,128,130,132,156
2	051-4702-0	RES,CARBON FILM,4.7K OHM,1/4W,5%	8	R9,12,64,75,117,119,154,156

LVL	PART#	DESCRIPTION	QTY	REF. DESIG.
2	051-4703-0	RES,CARBON FILM,47K OHM,1/4W,5%	14	R5,48,76,78,109,143,167,168,173,174,183 184,190,191
2	051-4704-0	RES,CARBON FILM,470K OHM,1/4W,5%	1	R79
2	051-5602-0	RES,CARBON FILM,5.6K OHM,1/4W,5%	12	R44,45,47,51,77,116,150,215,222,225,231
2	051-5603-0	RES,CARBON FILM,56K OHM,1/4W,5%	11	R10,80,86,163,164,200,201,204,206,208, 210
2	051-5604-0	RES,CARBON FILM,560K OHM,1/4W,5%	2	R84,178
2	052-0000-0	RES,METAL WIRE, 0 OHM,1/4W,1%	8	
2	054-2702-0	RES,CARBON FILM,2.7K OHM,1W,5%	4	R120,122,153,155
2	056-.330-0	RES,CERAMIC WW,.33 OHM,5W,10%	6	R106,123,127,133,139,157
2	056-0500-0	RES,CERAMIC WW,5 OHM,5W,10%	2	R124,134
2	070-0506-0	POT,50KA,9MM,PLASTIC KNURL 14MM,.05W	2	R20,38- VOLUME POTS
2	070-0508-0	POT,1K TRIM,6MM,SLOT,.3W	3	R14,96,114,147
2	070-0509-0	POT,20K TRIM,6MM,SLOT,.3W	4	R18,35,36,37
2	070-0514-0	POT,50KB,LINEAR,9MM,METAL KNURL 9MM,.1W	4	R46,50,61,71- TREBLE, MIDS, BASS
2	090-0013-0	SWITCH,PP,DPDT,.2A,PC MOUNT	6	S1,2,3,4,5,6 - ALL SWITCHES
2	092-0201-0	JACK SW-RN112APC,1/4",S-TIP,SLDR TERM	2	J1,7 - INPUT JACK
2	092-0202-0	JACK SW-RN114BPC,1/4",S-TIP,S-RING,P.C.	2	J2,3 - FOOTSW./PHONE JACKS
2	092-0203-0	JACK SW-RN111PC,1/4",O-TIP,P.C. TERM	3	J4,6,8
2	092-0204-0	JACK SW-RN112BPC,1/4",O-TIP,O-RING,P.C.	1	J9
2	093-0028-0	HEADER,3X.156,MALE,LOCK	1	
2	093-0029-0	HEADER,4X.156,MALE,LOCK	1	
2	145-0049-A	250ML BOARD	1	
1	602-0007-0	FORMS,WARRANTY CARDS	1	