

**INSTRUCTION  
MANUAL  
FOR**

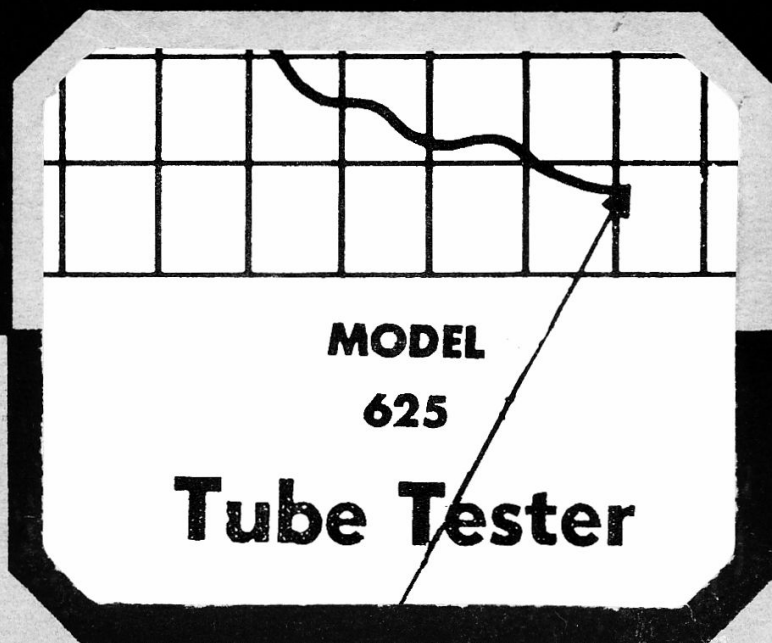

**ELECTRONIC  
INSTRUMENT CO., Inc.**

**84 WITHERS STREET , BROOKLYN 11, N. Y.**

**INSTRUCTION  
MANUAL  
FOR**

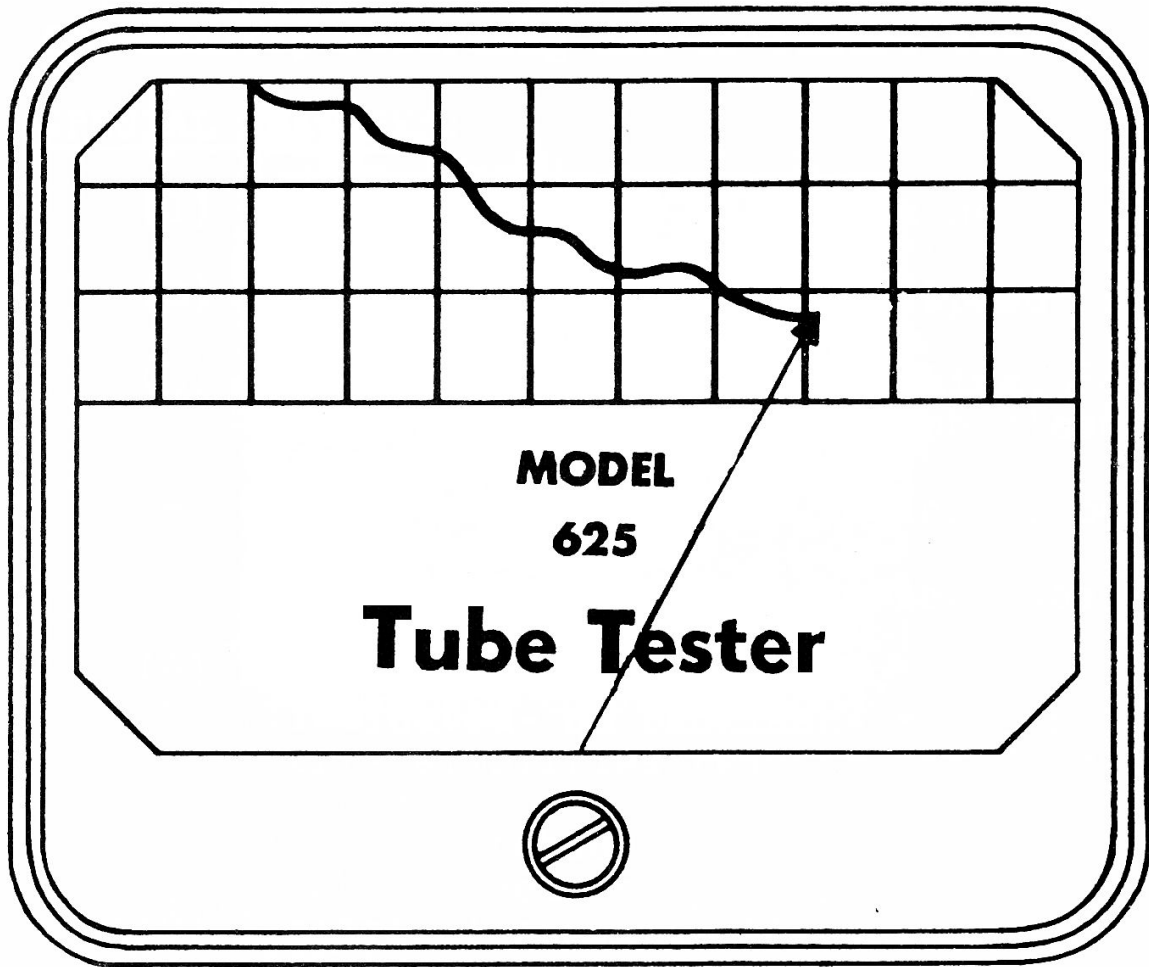

**ELECTRONIC  
INSTRUMENT CO., Inc.**

# EICO TUBE TESTER MODEL 625

## DESCRIPTION

The Model 625 Tube Tester has been designed to test practically all current radio and television receiving and a number of commonly encountered transmitting tubes. With this basic purpose in mind, concentration is next placed on simplicity of operation and circuit flexibility regarding new or future tubes.

## SPECIAL FEATURES:

- (1) Tests practically all tubes as described above.
- (2) Speed type lever switches- speed and accuracy.
- (3) Individual tube element testing. Specially designed against obsolescence to accomodate future tubes.
- (4) Circuit overload bulb- indicates overload on transformer.
- (5) Short test- indicates shorted tube elements.
- (6) Large- easy-to-read meter.
- (7) Illuminated- no backlash- speed roll chart- simplifies reading and finding of tubes.
- (8) Lifetime etched, rub-proof panel.
- (9) Durable steel carrying case.
- (10) Electrical specifications:  
105- 125V AC, 50-60 cycles.
- (11) Mechanical specifications: 12½" wide;  
5½" deep; 11½" high.

## OPERATION

Testing a tube is merely a simple series of steps.

NOTE: Do not plug tube into socket until all controls are set.

- (1) TUBE NUMBER: Select the tube number under the heading marked "TUBE" on the roll chart.
- (2) SHUNT: Adjust the SHUNT CONTROL on the panel to the number marked on the roll chart.
- (3) FILAMENT: Set the FILAMENT switch to the same value as shown on the chart.\*
- (4) SELECTOR: Set the SELECTOR SWITCH as indicated on the roll chart.

The next two columns are for the 10 lever switches and refer to their "up" and "down" positions. UNLESS OTHERWISE INDICATED LEAVE ALL SWITCHES IN THEIR CENTER POSITION.

- (5) UP: Move lever switches numbered on "up" column of roll chart to the "up" position.
- (6) DOWN: Move lever switches numbered on "down" column of roll chart to the "down" position.
- (7) Insert tube in proper socket and turn power on.
- (8) LINE ADJUST: (a) Set SELECTOR switch to "Line Adj." position. (b) Adjust LINE ADJUST potentiometer until meter reads within a division of "Line."
- (9) SHORT: Neon bulb will light after preceding step only if a short is present. Do not test a shorted tube any further as damage will result. (See SHORT TEST instructions which follow.)

\* Since the FILAMENT selector will apply any voltage selected to a tube under test, care should be taken to check this setting in order that no higher than rated voltage be applied. Disregarding this may cause burning out of the tube under test. This is true in all tube testers.

(10) MERIT SWITCH: Depressing this switch will indicate the condition of the tube.

Example. Testing a 6J5 tube:

Under the roll chart heading of 6J5, the following adjustments appear:

<u>TUBE</u>	<u>SHUNT</u>	<u>FIL</u>	<u>SEL</u>	<u>UP</u>	<u>DOWN</u>
6J5	24	6.3	2	3,5	<b>7,8</b>

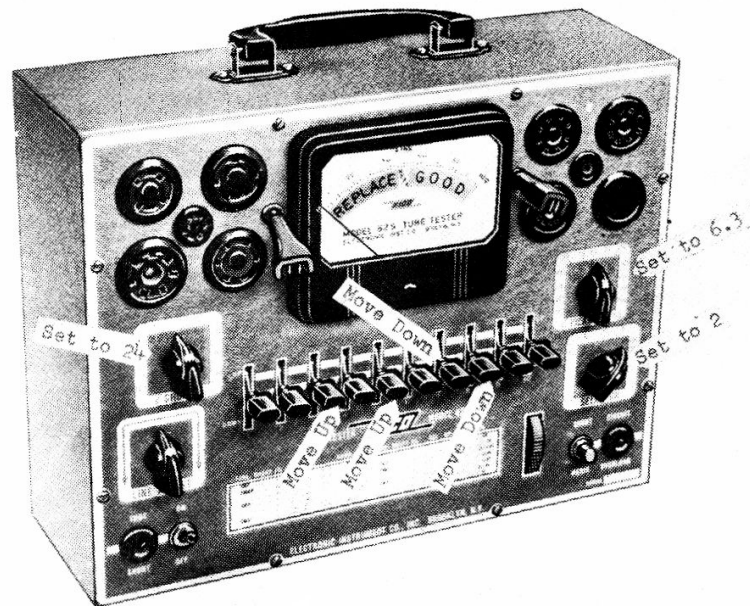

If more than one listing is given on the roll chart (6SQ7, 6J6, etc.) it is because the tube under test is multipurpose. The procedure is to test the first row of figures, then reset and test the second, third, etc. If any test shows bad, the tube is defective.

### GRID CAPS

The EICO Model 625K has been designed with two grid caps, a feature usually available only in more expensive equipment, since many tubes

are so provided. Note: In all cases, except those tubes requiring 2 grid caps, the right side cap will be used. The right side grid cap is controlled by lever switch #10; the left side grid cap by lever switch #9.

### OVERLOAD

The OVERLOAD bulb is an extremely important feature for a tube tester. It indicates transformer overload. In the event a tube with a shorted filament were inserted into a tube tester which does not have this feature, the transformer would tend to overheat and possibly burn out. In the EICO Model 625, a filament short will be indicated by the OVERLOAD bulb lighting. In this case the tube under test should immediately be removed.

Note: On occasion the bulb may light instantaneously when the AC plug is inserted. This is a case of surge and may be ignored.

### SHORT

**FOR "SHORT", "OPEN ELEMENT" & "FILAMENT CONTINUITY" TESTING SEE "REVISED PROCEDURE"**

## REPLACE, WEAK, GOOD

If a tube reads in the "REPLACE" region, it has low emission and should be replaced. If it reads in the "WEAK" region, it is questionable, but probably operative. If it reads in the "GOOD" region, the tube has proper emission. The 0-1000 scale on the meter is for tube matching.

TUBE MERIT: This is a momentary contact switch and when depressed indicates the emission characteristic of the tube.

PILOT LIGHT TEST: Pilot lights may be tested by selecting the proper filament voltage on the FILAMENT switch and inserting the pilot light into the center of the large 7 prong socket.

FILAMENT CONTINUITY:

**FOR "SHORT", "OPEN ELEMENT" & "FILAMENT CONTINUITY" TESTING SEE "REVISED PROCEDURE"**

OPEN ELEMENT TEST:

**FOR "SHORT", "OPEN ELEMENT" & "FILAMENT CONTINUITY" TESTING SEE "REVISED PROCEDURE"**

NEW TUBES: EICO, in accordance with its recognized policy of protecting all instruments against obsolescence will periodically issue new roll charts and data sheets. If you will send your name and a self-addressed

## *Revised Procedure;*

REVISED PROCEDURE FOR "SHORT" TESTING, "OPEN ELEMENT" TESTING, & "FILAMENT CONTINUITY" TESTING. (All these tests are performed at once in this procedure. Supersedes "SHORT", "OPEN ELEMENT", & "FILAMENT CONTINUITY" test procedures on pages 4 & 5 of the Instruction Book. Note that the test procedure that follows must be performed before the MERIT test on any tube or section of a tube to eliminate the possibility of damage to the tube tester by MERIT testing an internally shorted tube.)

1. Set levers for the MERIT test (or the first MERIT test if the tube has more than one section and therefore receives more than one MERIT test).
2. If there is a short indication (neon SHORT lamp glows steadily) at this point, the tube is internally shorted and should be discarded. If there is no short indication, proceed as follows.
3. One by one move each UP lever to DOWN and return and each DOWN lever to UP and return. Do not move levers left in the center position. Levers not underlined on the roll chart should not show short at the opposite position. Levers underlined should show short at the opposite position. A short indicator on a lever not underlined means the tube is defective because of an inter-element short. Failure to obtain the short indication on an underlined lever means the tube is defective due to an open element (includes filament discontinuity). (Note: A momentary flicker of the neon short lamp on moving a lever through a position is not significant.)
4. Repeat steps 1, 2, and 3 for each section of a multi-section tube before MERIT testing each section.



envelope, you will be notified when the new charts are available and their cost. The latter will be nominal.

Although it is possible for the serviceman to develop the settings for new tubes, it is not recommended due to the extra equipment necessary.

For an interim period, "between the old and new roll charts," the following procedure may be used for determining the settings for new tubes.

- (1) Move all levers to the "down" position.
- (2) Move either one of the filament levers to the center position.
- (3) Move the grid, screen, suppressor and plate levers to the "up" position.
- (4) If the normal current rating of the tube is between zero and 3 ma. use position 1 on the SELECTOR switch; position 2 for tubes from 3-15 ma; position 3 for filament type above 15 ma; position 4 for gaseous and magic eye tubes.
- (5) Move the FILAMENT switch to the proper filament voltage.
- (6) Starting with the SHUNT control at zero, depress the MERIT switch and gradually increase the "Shunt" setting until the meter reads approximately 800.
- (7) Check several other tubes and use the average "SHUNT" reading for the "SHUNT" setting.

GUARANTEE:- The Electronic Instrument Company guarantees to replace any part or component which proves defective under normal use within 90 days of purchase date.



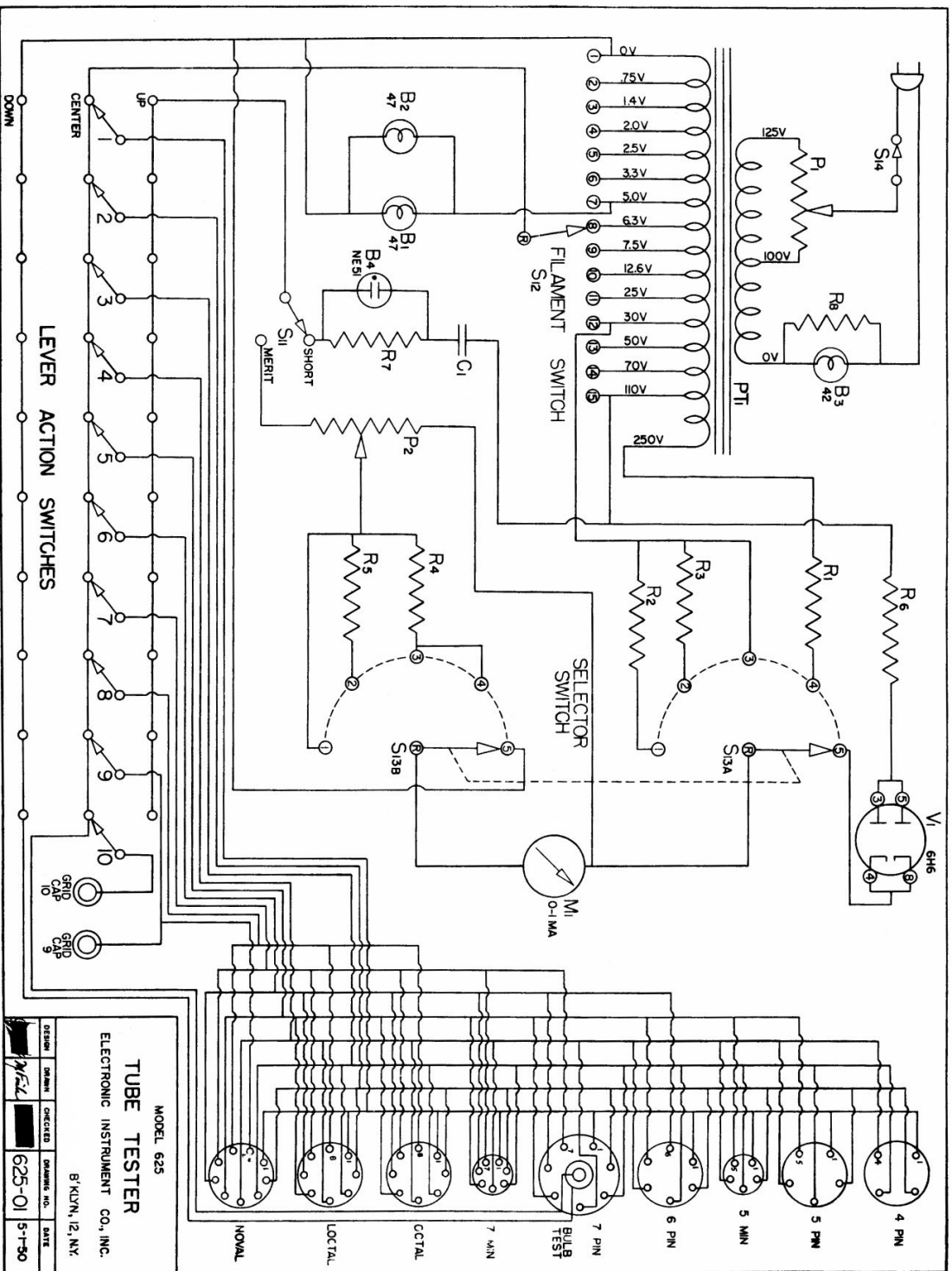

MODEL 625  
**TUBE TESTER**  
 ELECTRONIC INSTRUMENT CO., INC.  
 8 KILYN, 12, N.Y.

DESIGN	NAME	CHECKED	DRAWING NO.	DATE
			625-01	5-1-30

PART #	SYMBOL	SPECIFICATION
1	B1	#47 PILOT LIGHT
2	B2	#47 PILOT LIGHT
3	B3	#42 OVERLOAD
4	B4	NE-51 SHORT IND.
7	C1	.005 MFD COND.
8	M1	0-1 MA METER
10	P1	100-200 OHM 25W. POT.
11	P2	200 OHM POT.
12	R1	2500 OHM 5W RES.
13	R2	4700 OHM 5% RES.
14	R3	820 OHM 5% RES.
15	R4	1600 OHM 5% RES.
16	R5	510 OHM 5% RES.
17	R6	95K OHM 1/2 RES.
18	R7	1M OHM RES.
19	R8	3-5 OHM RES.
20	S10	3-5 OHM RES.
21	S11	SPST LEVER ACTION
22	S12	SPST PUSH BUTTON
23	S13	SP 15 POS. FIL. SW.
24	S14	DP 5 POS. SBL. SW.
25	S14	SPST ON-OFF SW.
26	V1	6H6 TUBE