

COMPONENT SIDE SHOWN

403-0044 REV C
 GALLIEN-KRUEGER

Q.#	DATE

GALLIEN-KRUEGER		MODEL #:	800RB	DATE:	3/30/92	DESCRIPTION:	NEW 800RB POWER AMP BOARD
CIRCUIT BOARD	DBF:	DESIGNED BY:	R.A.G.	BOARD #:	206-0044-C	REV#-DATE:	FROM SN: TO SN:
ARTWORK	50044C						

603.0004.4.20

403-0048 REV B
 GALLIEN-KRUEGER

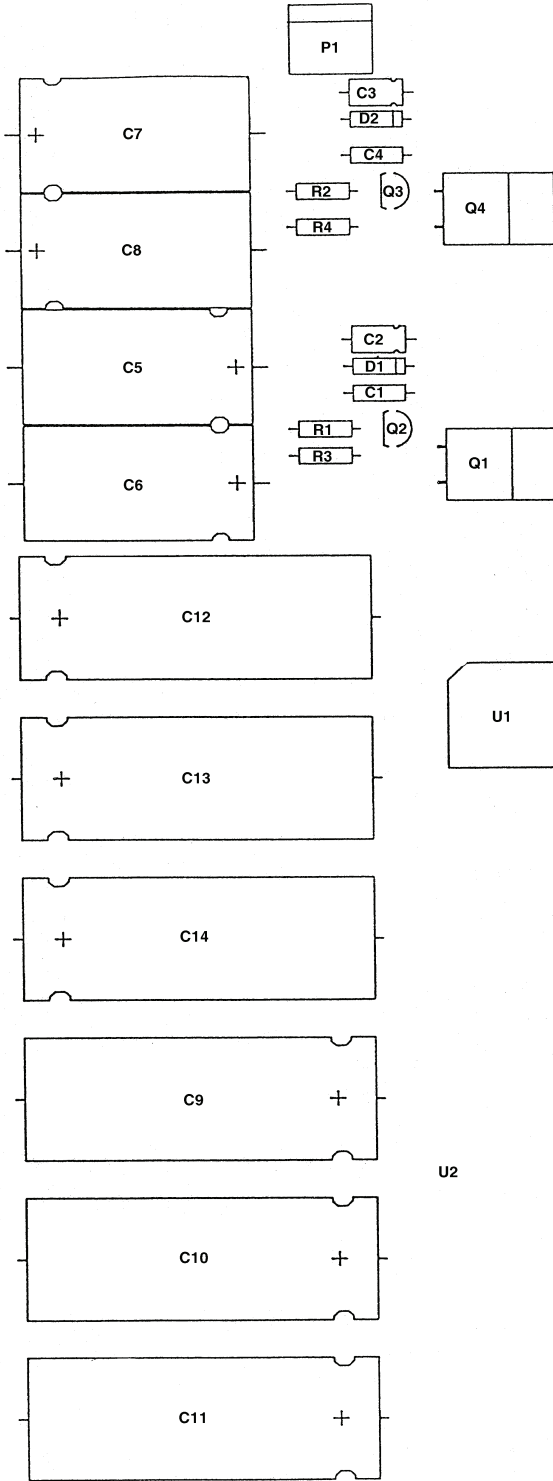

PCO#	DATE

GALLIEN-KRUEGER		MODEL #:	800RB	DATE:	8/29/91	DESCRIPTION:	NEW 800RB POWER SUPPLY
CIRCUIT BOARD ARTWORK	DBF: 50048B	DESIGNED BY:	R.A.G.	BOARD #:	206-0048-B	REV#-DATE:	FROM SN: TO SN:

GALLIEN-KRUEGER	PRODUCTION CHANGE ORDER	PCO#: 3
DATE: 7/23/91	ASSEMBLY #: 2060045 A	MODEL#: 800RB
ASSEMBLY DESCRIPTION: 800RB preamp board		PAGE 1 OF 3

AFFECTS OPTIONS: ALL 100V 120V 220V 240V 50HZ 60HZ

TYPE OF CHANGE:

- NECESSARY TO THE FUNCTION OF THE UNIT
- IMPROVEMENT OR ADDITION TO THE UNIT
- OTHER Using different values pots

CHANGE TO BE IMPLEMENTED TO:

- NEXT PRODUCTION RUN
- ALL UNITS IN PRODUCTION
- ALL UNITS IN STOCK
- ALL UNITS BEING SERVICED
- OTHER units that don't have 25KB pots

REMARKS: Ran out of CTS 25K pots (in Linear version). Have to modify boards to take the 50KB pot we use on the other amps. Use 50KB's for the 4 tone controls and the crossover.

BEGINNING SERIAL NUMBER AFFECTED:

DESCRIPTION OF CHANGE: SEE PCO SUPPLEMENTS CONTINUED ON PCO SUPPLEMENT PAGE _____

1) Change the Following

- R19, R25, R31, R34, R67: 25K pot → 50KB pot
- R30: 12K → 22K res
- R17, R22, R23, R27: 4.7K → 12K res.
- R29, R32, R33, R36: 3.3K → 5.6K res.
- R20, R21, R26, R28: 220K → 470K res.
- R18, R24, R35: 22K → 47K res
- C11, C12, C17: 472 → 222 cap
- C13, C14: 223 → 103 cap
- C16: 224 → 104 cap

2) Add 27PF cap across R21 (470K)

REASON FOR CHANGE:

- 1) to use 50KB pots in place of 25KB pots
- 2) stops high freq. oscillation

PARTS ADDED				PARTS DELETED			
PART#	DESCRIPTION	QTY.	REF. DES.	PART#	DESCRIPTION	QTY.	REF. DES.
	27 pF cap	1					
070-0514	50KB Noble pot	5	R19,25,31,34,67		25KB CTS pot	5	R19,25,31,34,67
051-1203	12K res	4	R17,22,23,27	051-4702	4.7 Kres	4	R17,22,23,27
051-5602	5.6K res	4	R29,32,33,36	051-3302	3.3K res	4	R29,32,33,36
051-4704	470K res	4	R20,21,26,28	051-2204	220K res	4	R20,21,26,28
051-4703	47K res	3	R18,24,35	051-2203	22K res	3	R18,24,35
030-2222	222 cap	3	C11,12,17	030-2472	472 cap	3	C11,12,17
030-1103	103 cap	2	C13,14	030-0223	223 cap	2	C13,14
030-4104	104 cap	1	C16	030-2224	224 cap	1	C16
051-2203	22K res	1	R30	051-1203	12K res	1	R30

CONTINUED ON PAGE _____

CONTINUED ON PAGE _____

AFFECTED AREAS	DONE BY	DATE	AFFECTED AREAS (CONT)	DONE BY	DATE
<input checked="" type="checkbox"/> CIRCUIT SCHEMATIC	mg	7/23/91	<input type="checkbox"/>		
<input checked="" type="checkbox"/> BILL OF MATERIAL			<input type="checkbox"/>		
<input type="checkbox"/> AUTO INSERTER			<input type="checkbox"/>		
<input checked="" type="checkbox"/> SAMPLE CHANGE			DOCUMENT DIST. LIST	# COPIES	
<input type="checkbox"/> TEST PROCEDURE			<input type="checkbox"/> GK USA		
<input type="checkbox"/> COMP. CONTROL FORM			<input type="checkbox"/> SERVICE CENTERS		
<input type="checkbox"/> FAB DRAWING			<input type="checkbox"/> GK EUROPE		
<input type="checkbox"/> PUNCH PROGRAM			<input checked="" type="checkbox"/> GK CAMPBELL		
<input type="checkbox"/> PUNCH SAMPLE			<input checked="" type="checkbox"/> ENGINEERING		
<input type="checkbox"/> ASSEMBLY PROCEDURES			<input type="checkbox"/> FABRICATION		
<input type="checkbox"/> ARTWORK			<input type="checkbox"/> PRODUCTION		
<input type="checkbox"/> SILKSCREEN TEMPLATE			<input type="checkbox"/> OUTSIDE SUPPLIERS		
<input type="checkbox"/>			<input type="checkbox"/>		

DRAWING(S) SHOWING MODIFICATION ATTACHED: NO YES - SPECIFY: Schem & Layout

WRITTEN BY: Michael Johns

DEPT: Eng

DATE: 7/23/91

REVIEWED/APPROVED BY:

DEPT:

DATE:

GALLIEN-KRUEGER	PRODUCTION CHANGE ORDER	PCO#: <u>400RB: 7</u> <u>800RB: 11</u>
DATE: 2/1/93	ASSEMBLY #: 302-0050 / 302-0060	MODEL#: 400RB/800RB
ASSEMBLY DESCRIPTION: 400RB/800RB Main Assembly		PAGE <u>1</u> OF <u>1</u>

AFFECTS OPTIONS: ALL 100V 120V 220V 240V 50HZ 60HZ

TYPE OF CHANGE:
 NECESSARY TO THE FUNCTION OF THE UNIT
 IMPROVEMENT OR ADDITION TO THE UNIT
 OTHER Done for CSA Approval

CHANGE TO BE IMPLEMENTED TO:
 NEXT PRODUCTION RUN
 ALL UNITS IN PRODUCTION
 ALL UNITS IN STOCK
 ALL UNITS BEING SERVICED
 OTHER _____

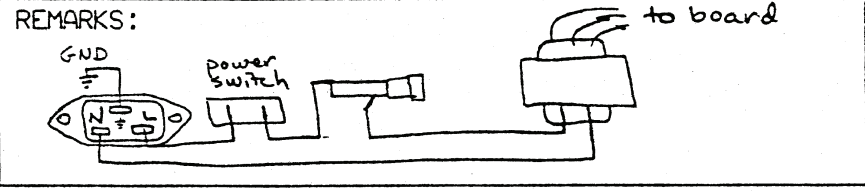

BEGINNING SERIAL NUMBER AFFECTED: _____

DESCRIPTION OF CHANGE: SEE PCO SUPPLEMENTS CONTINUED ON PCO SUPPLEMENT PAGE _____

When wiring up power supply, wire from "L" terminal of AC receptical to the power switch. Then wire from the power switch to the end lug of the fuse holder. Then from the other lug of the fuse holder to the transformer. The wire from the "N" terminal goes directly to the transformer.

REASON FOR CHANGE:
 CSA requires these changes for approval.

PARTS ADDED				PARTS DELETED			
PART#	DESCRIPTION	QTY.	REF. DES.	PART#	DESCRIPTION	QTY.	REF. DES.

CONTINUED ON PAGE _____ CONTINUED ON PAGE _____

AFFECTED AREAS	DONE BY	DATE	AFFECTED AREAS (CONT)	DONE BY	DATE
<input type="checkbox"/> CIRCUIT SCHEMATIC			<input type="checkbox"/>		
<input type="checkbox"/> BILL OF MATERIAL			<input type="checkbox"/>		
<input type="checkbox"/> AUTO INSERTER			<input type="checkbox"/>		
<input checked="" type="checkbox"/> SAMPLE CHANGE			DOCUMENT DIST. LIST	# COPIES	
<input type="checkbox"/> TEST PROCEDURE			<input type="checkbox"/> GK USA		
<input type="checkbox"/> COMP. CONTROL FORM			<input type="checkbox"/> SERVICE CENTERS		
<input type="checkbox"/> FAB DRAWING			<input type="checkbox"/> GK EUROPE		
<input type="checkbox"/> PUNCH PROGRAM			<input type="checkbox"/> GK CAMPBELL		
<input type="checkbox"/> PUNCH SAMPLE			<input type="checkbox"/> ENGINEERING		
<input type="checkbox"/> ASSEMBLY PROCEDURES			<input type="checkbox"/> FABRICATION		
<input type="checkbox"/> ARTWORK			<input type="checkbox"/> PRODUCTION		
<input type="checkbox"/> SILKSCREEN TEMPLATE			<input type="checkbox"/> OUTSIDE SUPPLIERS		
<input type="checkbox"/>			<input type="checkbox"/>		

DRAWING(S) SHOWING MODIFICATION ATTACHED: NO YES - SPECIFY:

WRITTEN BY: Michael Johns DEPT: Eng DATE: 2/1/93
 REVIEWED/APPROVED BY: _____ DEPT: _____ DATE: _____

ENGINEERING CHANGE ORDER MODEL: 800RB

STOMER Gallien-Krueger LEVEL: System DATE: 2/14/95
 DESC. 800RB preamp Board ORIGINATOR: M Johns
 ASSY# 206-0045 (145-0045) REV# C6 → D Fab

<input checked="" type="checkbox"/> EFFECTIVE	<input type="checkbox"/> PENDING	APPROVAL	INITIAL	DATE
<input type="checkbox"/> Next production Run	Pending/Reject Reason:	Engineering	<u>MJ</u>	<u>2/14/95</u>
<input type="checkbox"/> All in Process	Type of Change: <input type="checkbox"/> Necessary <input checked="" type="checkbox"/> Improvement <input type="checkbox"/> Other:	Material		
<input type="checkbox"/> All in Stock		Production		
<input type="checkbox"/> All being Serviced		Fabrication		
<input checked="" type="checkbox"/> Others: <u>when order is placed for new boards</u>		Marketing		
		Cost accounting		

REASON FOR CHANGE:
To replace TL604 w/ Siliconix DG419
 Continued on ECO supplement page _____

AFFECTED AREA:

Schematic

Artwork

Bill of Material

Comp. Control Form

Assembly Drawing

Test Procedure

Fab Drawing

Silkscreen

Punch Program

DESCRIPTION OF CHANGE:
Board is re-layed out to accomodate DG419 instead of TL604. Rev # goes from C6 to D.
 Continued on ECO supplement page _____

TOTAL PARTS ADDED:				TOTAL PARTS DELETED:			
PART#	DESCRIPTION	QTY	REF.DES.	PART#	DESCRIPTION	QTY	REF.DES.
	1K res	1	R86A		224 cap	1	C61
	2.2K res	1	R87A		4.7K res	1	R63
	335 cap	2	C61, C70		12K res	1	R73
	220R res	2	R63, R81		104 cap	1	C70
	470R res	1	R73		50KB pot	1	R82

DISTRIBUTION: Engineering Material Production Fabrication Others: over →

GALLIEN TECHNOLOGY

Tel: (408) 441-8081

2240 Paragon Dr., San Jose, CA 95131

Fax: (408) 441-8085

ECO#

16

ENGINEERING CHANGE ORDER

MODEL:
800RB

CUSTOMER Gallien - Krueger
 DESC. 800RB
 ASSY# 206-0044 REV# C8

LEVEL: System
 Board
 Fab

DATE: 8/28/95
 ORIGINATOR: Kevin Robertson

EFFECTIVE 8/28/95
 Next production Run
 All in Process
 All in Stock
 All being Serviced
 Others:

PENDING
 Pending/Reject Reason:
 Type of Change: Necessary
 Improvement
 Other:

APPROVAL	INITIAL	DATE
Engineering		
Material		
Production		
Fabrication		
Marketing		
Cost accounting		

REASON FOR CHANGE:
Output Clipping before Full Power, decreasing resistor value allows an increased current drive to output stage.
 Continued on ECO supplement page _____

AFFECTED AREA:
 Schematic DR 8/28/95
 Artwork
 Bill of Material DR 8/28/95
 Comp. Control Form
 Assembly Drawing
 Test Procedure
 Fab Drawing
 Silkscreen
 Punch Program

DESCRIPTION OF CHANGE:
Substitution of a different resistor value, 2.2k in place of 3.3k at R34.
 Continued on ECO supplement page _____

TOTAL PARTS ADDED:				TOTAL PARTS DELETED:			
PART#	DESCRIPTION	QTY	REF.DES.	PART#	DESCRIPTION	QTY	REF.DES.
<u>051-3202-0</u>	<u>2.2k 1/4 watt</u>	<u>1</u>	<u>R34</u>	<u>051-3362-0</u>	<u>3.3k 1/4 watt</u>	<u>1</u>	<u>R34</u>

DISTRIBUTION: Engineering Material Production Fabrication Others: SALES

ENGINEERING CHANGE ORDER

MODEL: 800RB

CUSTOMER: Gallien Kueger
DESC: 800RB preamp board
ASSY#: 206-0045-D REV#: D

LEVEL: System
 Board
 Fab

DATE: 11/6/95
ORIGINATOR: M Johns

<input checked="" type="checkbox"/> EFFECTIVE	<input type="checkbox"/> PENDING	APPROVAL	INITIAL	DATE
<input checked="" type="checkbox"/> Next production Run	Pending/Reject Reason:	Engineering	MJ	11/6/95
<input checked="" type="checkbox"/> All in Process		Material		
<input type="checkbox"/> All in Stock	Type of Change: <input type="checkbox"/> Necessary <input type="checkbox"/> Improvement <input checked="" type="checkbox"/> Other:	Production		
<input type="checkbox"/> All being Serviced		Fabrication		
<input checked="" type="checkbox"/> Others: Until old boards and front panels are used up		Marketing	RK (MJ)	11/6/95
		Cost accounting		

REASON FOR CHANGE:
Substitute 50KB pot in Boost control until changeover is made with new 2KB pot and new boards. (Undoes some of ECO#15)
^ D17 revision

Continued on ECO supplement page _____

AFFECTED AREA:

Schematic

Artwork

Bill of Material

Comp. Control Form

Assembly Drawing

Test Procedure

Fab Drawing

Silkscreen

Punch Program

DESCRIPTION OF CHANGE:

- Change C61 from 335 to 224
- " R63 " 220R → 4.7K
- " C70 " 335 → 104
- " R73 " 470R → 12K
- " R82 " 2KB pot → 50KB pot
- " R81 " 220R → 5.6K
- " R84 " 47K → 220K

Continued on ECO supplement page _____

TOTAL PARTS ADDED:				TOTAL PARTS DELETED:			
PART#	DESCRIPTION	QTY	REF.DES.	PART#	DESCRIPTION	QTY	REF.DES.
	224 cap	1	C61		335 cap	1	C61, 70
	4.7K res	1	R63		220R res	1*	R63, 81
	104 cap	1	C70		470R res	1	R73
	12K res	1	R73		2KB pot	1	R82
	50KB pot	1	R82		47K res	1	R84
	5.6K res	1	R81				
	220K res	1	R84				

DISTRIBUTION: Engineering Material Production Fabrication Others: _____

ENGINEERING CHANGE ORDER

MODEL:

800RB

CUSTOMER: Gallien Knege
 DESC: 800 RB preamp board
 ASSY#: 145-0045-D, 206-0045-D REV# D→E

LEVEL: System
 Board
 Fab

DATE: 5/7/96
 ORIGINATOR: M Johns

EFFECTIVE
 Next production Run
 All in Process
 All in Stock
 All being Serviced
 Others:

PENDING
 Pending/Reject Reason:
 Type of Change: Necessary
 Improvement
 Other:

APPROVAL	INITIAL	DATE
Engineering	<u>MJ</u>	<u>5/7/96</u>
Material		
Production		
Fabrication		
Marketing		
Cost accounting		

REASON FOR CHANGE:
use new pots, 7mm bushing instead of 9mm
 Continued on ECO supplement page

AFFECTED AREA:
 Schematic
 Artwork
 Bill of Material
 Comp. Control Form
 Assembly Drawing
 Test Procedure
 Fab Drawing
John to change front panel.
 Silkscreen
 Punch Program

DESCRIPTION OF CHANGE:
 1) all pots change from 9mm version to 7mm
 2) R60 (22K) moves on layout
 3) adds 2 jumpers R17A and R115A
 Continued on ECO supplement page

TOTAL PARTS ADDED:				TOTAL PARTS DELETED:			
PART#	DESCRIPTION	QTY	REF.DES.	PART#	DESCRIPTION	QTY	REF.DES.
052-0000-0	0.52 res	2	R17A, R115A	070-1513-0	50KA pot 9mm	1	R17
070-1513-0	50KA pot 7mm	1	R17	070-0514-0	50KB pot 9mm	6	R36, 53, 64, 68, 115, 118
070-1514-0	50KB pot 7mm	6	R36, 53, 64, 68, 115	070-0522-0	2KB pot 9mm	1	R82
070-1522-0	2KB pot 7mm	1	R82	070-0523-0	50KB dual pot 9mm	1	R100
070-1523-0	50KB dual pot 7mm	1	R100				

DISTRIBUTION:
 Engineering Material Production Fabrication Others:

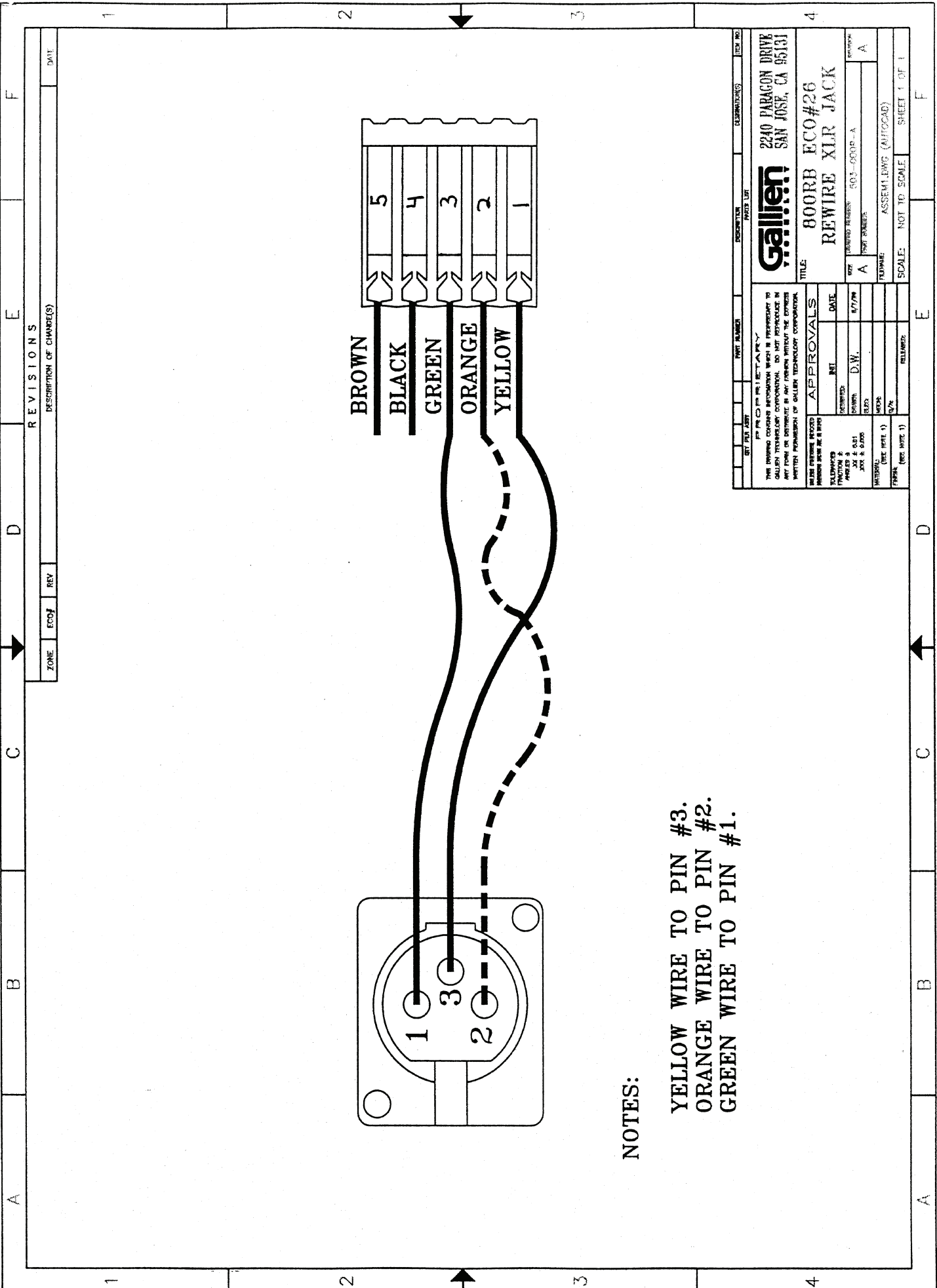

NOTES:

- YELLOW WIRE TO PIN #3.
- ORANGE WIRE TO PIN #2.
- GREEN WIRE TO PIN #1.

REVISIONS		DATE
ZONE	ECO#	REV

REV. NO.	DESCRIPTION	DATE	BY

Galien
2240 PARAGON DRIVE
SAN JOSE, CA 95131

TITLE: **800RB ECO#26
REWIRE XLR JACK**

DATE	BY	REVISED BY	DATE

APPROVALS

DESIGNED	DATE
D.W.	8/7/98

WORKSHEET NO. 503-0000-A

ASSEMBLY (AUG00AD)

SCALE: NOT TO SCALE

SHEET 1 OF 1

800RB

6/22/99

INDENTED BILL OF MATERIALS

Most commonly needed parts are italicized.

Main assembly numbers are in bold face.

* Level 1 refers to main asy.

Level 2 refers to board pts.

LVL.*	PART#	DESCRIPTION	QTY	REF. DESIG.
1	010-0012-0	MPSA06 NPN 80V 500MA TO-92	2	
1	011-0002-0	TIP31C NPN 80V 3A TO-220	2	
1	011-0007-0	MJE15030 NPN 150V 8A TO-220	1	
1	011-1008-0	MJE15031 PNP 150V 8A TO-220	2	
1	013-0026-0	MJ-15022 NPN 200V 16A TO-3	5	
1	013-1027-0	MJ-15023 PNP 200V 16A TO-3	6	
1	023-0106-0	KBPC25-02 BRIDGE RECT,25A,200V,C224B	1	
1	023-0108-0	KBPC-602 BRIDGE RECT,6A,200V,C216A	1	
1	056-.330-0	RES,CERAMIC WW,.33 OHM,5W,10%	8	
1	<i>080-0004-0</i>	<i>800RB TRANSFORMER,100/300W,120V,Z=8/4</i>	1	
1	090-0008-0	SWITCH,ROCKER,SPST,4A,QUICK-TERM	1	
1	091-0010-0	FUSE, 8A,125V,1/4X1 1/4,SLB	1	
1	092-0002-0	JACK SW-11,1/4",O-TIP,SLDR TERM	3	
1	092-0004-0	JACK SW-L11,1/4",O-TIP,SLDR TERM,LONG	1	
1	092-0011-0	JACK SW-L12A,1/4",S-TIP,LONG	1	
1	092-0045-0	XLR,MALE,X70101 LUGS	1	
1	092-0064-0	Q-CON, .25 TAB,18-22GA,INSULATED	5	
1	<i>093-0014-0</i>	<i>RECEPTICAL AC,Q-TERM</i>	1	
1	093-0023-0	HOUSING,5X.156,FEMALE LOCK	2	
1	093-0032-0	HOUSING,3X.156,FEMALE 22GA,LOCK	2	
1	093-0083-0	HOUSING,2X.156,FEMALE,22GA,LOCK	1	
1	<i>094-0013-0</i>	<i>HOLDER,FUSE,1/4 X 1 1/4,Q-TERM</i>	1	
1	094-0019-0	SOLDER LUG,#6	1	

LVL.	PART#	DESCRIPTION	QTY	REF. DESIG.
1	095-0005-0	POWER CORD, 117V PLUG, DETACH	1	
1	100-0000-0	INSULATOR, MICA, 56-03-2AP, TO3	11	
1	100-0020-0	BUMPER, ROUND RUBBER, 1/2" X .14"	4	
1	100-0030-0	BUTTON, RECT BLACK CAP - PUSH SWITCH	5	
1	100-0031-0	WASHER, #4, RECT, TO-220 MGT	5	
1	100-0032-0	INSULATOR, MICA, 56-77-11AP, TO-220	5	
1	100-0033-0	CABLE TIE - PLT 1M-M, SMALL	6	
1	100-0037-0	HEAT CLIP, TO-98	2	
1	100-0041-0	WIRE HOLDER N-4	2	
1	100-0042-0	HANDLE, RUBBER, 6.5"	1	
1	100-0076-0	FOOT, RUBBER, ROUND, 5/8 DIA. X 5/8"	4	
1	100-0102-0	CAP, .72 APLS SPLINE SHAFT	9	
1	100-0103-0	KNOB, .72 APLS SPLINE SHAFT	9	
1	111-0081-0	BOLT 4-40 1/2 PHP CAD	1	
1	111-6001-0	NUT 4-40 KEP SMALL	1	
1	112-0061-0	BOLT 6-32 3/8 PHP CAD	1	
1	112-0081-0	BOLT 6-32 1/2 PHP CAD	7	
1	112-0101-0	BOLT 6-32 5/8 PHP CAD	3	
1	112-0104-0	BOLT 6-32 5/8 PHP CAD WITH EXT SIM WAS	27	
1	112-0121-0	BOLT 6-32 3/4 PHP CAD	1	
1	112-4081-0	SCREW 6AB 1/2 FHP 82^ CAD	4	
1	112-6001-0	NUT 6-32 KEP LARG SIZE CAD	35	
1	112-8040-0	TR-BOLT 6-32 1/4 PHP B.O.	2	
1	112-8060-0	TR-BOLT 6-32 3/8 PHP B.O.	4	
1	112-9040-0	TR-BOLT 6-32 1/4 FHP B.O.	1	
1	112-9060-0	TR-BOLT 6-32 3/8 FHP B.O.	24	

LVL.	PART#	DESCRIPTION	QTY	REF. DESIG.
1	112-9101-0	TR-BOLT 6-32 5/8 FHP CAD	2	
1	114-0080-0	BOLT 10-32 1/2 PHP B.O.	9	
1	114-1040-0	BOLT 10-32 1/4 FHP 82^ B.O.	2	
1	114-1060-0	BOLT 10-32 3/8 FHP 82^ B.O.	4	
1	114-6001-0	NUT 10-32 KEP CAD	2	
1	114-7001-0	WASHER #10 LOCK CAD	4	
1	115-7005-0	WASHER 3/8 FIBRE FLAT	2	
1	115-7021-0	WASHER 3/8 INTERNAL CAD	12	
1	130-0023-A	800RB HEAT SINK	2	
1	130-0065-0	800RB FRONT PANEL OVERLAY	1	
1	130-0066-0	800RB REAR PANEL OVERLAY	1	
1	132-0321-D	800RB-II REAR PANEL	1	
2	120-0005-0	ALUM .100	141	
1	132-0324-A	800RB,100/300 UPPER SINK	1	
2	120-0006-0	ALUM .125	57	
1	132-0325-A	800RB,100/300 LOWER SINK	1	
2	120-0006-0	ALUM .125	57	
1	132-0326-A	800RB,POWER SUPPLY BRKT	1	
2	120-0005-0	ALUM .100	34	
1	132-0569-0	400RB-II COVER	2	
2	120-0005-0	ALUM .100	320	
1	132-0570-0	800RB-II FRONT PANEL	1	
2	114-6056-0	NUT 10-32 PRESS FOR STEEL	4	
2	120-0011-0	STEEL,18 GAUGE JET COAT,.048	147	
1	132-0572-0	800RB-II RIGHT SIDE	1	

LVL.	PART#	DESCRIPTION	QTY	REF. DESIG.
2	120-0005-0	ALUM .100	63	
1	132-0573-0	800RB-II LEFT SIDE	1	
2	120-0005-0	ALUM .100	63	
1	132-0574-0	800RB-II RACK EAR	2	
2	120-0005-0	ALUM .100	29	
1	150-0012-0	BOX,400-800	1	
1	150-0018-0	END CAP,800RB	2	
1	160-0004-0	MANUAL,800RB	1	

206-0044-C 800RB Power Amp

LVL	PART#	DESCRIPTION	QTY	REF. DESIG.
2	001-1030-0	LF353N DUAL JFET OP AMP	1	U1
2	010-0012-0	MPSA06 NPN 80V 500MA TO-92	4	Q1,Q6,Q15,Q14
2	010-1013-0	MPSA56 PNP 80V 500MA TO-92	4	Q3,Q4,Q14,Q16
2	020-2105-0	1N4002,RECT,1A,150V,DO-41	12	D1,D2,D3,D4,D5,D6,D7,D8,D9,D10,D11,D12
2	030-2101-0	CAP,CER,AX,101,10%,50V,NPO	2	C4,C11
2	030-2103-0	CAP,CER,AX,103,10%,50V,X7R	2	C5,C12
2	030-2104-0	CAP,CER,AX,104,10%,50V,X7R	4	C1,C6,C8,C13
2	030-2470-0	CAP,CER AXIAL,47 PF,10%,50V,NPO	2	C3,C10
2	031-2227-0	CAP,ELEC,RAD,227,-10%+50%,50V	2	C7,C14
2	038-0106-0	CAP,ELEC,AXIAL TR,106,20%,16V	2	C2,C9
2	051-0123-0	RES,CARBON FILM,1.2K OHM,1/4W,5%	1	R34
2	051-0221-0	RES,CARBON FILM,22 OHM,1/4W,5%	4	R20,R23,R47,R53
2	051-1001-0	RES,CARBON FILM,100 OHM,1/4W,5%	2	R11,R37
2	051-1002-0	RES,CARBON FILM,1K OHM,1/4W,5%	10	R8,R10,R16,R19,R24,R33,R36,R39,R43,R46
2	051-1004-0	RES,CARBON FILM,100K OHM,1/4W,5%	2	R1,R28
2	051-1005-0	RES,CARBON FILM,1M OHM,1/4W,5%	2	R3,R30
2	051-1203-0	RES,CARBON FILM,12K OHM,1/4W,5%	2	R4,R31
2	051-3302-0	RES,CARBON FILM,3.3K OHM,1/4W,5%	3	R7,R12,R38A
2	051-4701-0	RES,CARBON FILM,470 OHM,1/4W,5%	8	R13,R15,R21,R22,R44,R45,R51,R52
2	051-4703-0	RES,CARBON FILM,47K OHM,1/4W,5%	2	R2,R29
2	051-5603-0	RES,CARBON FILM,56K OHM,1/4W,5%	4	R5,R6,R32,R35
2	052-0000-0	RES,CARBON FILM 0 OHM,1/4W,5%	2	

LVL	PART#	DESCRIPTION	QTY	REF. DESIG.
2	054-2702-0	RES,CARBON FILM,2.7K OHM,1W,5%	6	R17,R18,R40,R41, ECO #25
2	056-0500-0	RES,CERAMIC WW,5.1 OHM,5W,10%	2	R27,R57
2	070-0508-0	POT,1K TRIM,6MM,SLOT,.3W	2	R14,R38
2	093-0028-0	HDR,.156X3,VERT,MALE,LOCK	1	P2
2	093-0033-0	HDR,.156X5,VERT,MALE,LOCK,ROUND	1	P1
2	145-0044-C	800RB POWER AMP BOARD	1	
		206-0048-C 800RB Power Supply		

LVL	PART#	DESCRIPTION	QTY	REF. DESIG.
2	010-0012-0	MPSA06 NPN 80V 500MA TO-92	1	Q2
2	010-1013-0	MPSA56 PNP 80V 500MA TO-92	1	Q3
2	020-0160-0	1N966B,ZENER,16V,5%,400MW,DO-35	2	D1,D2
2	030-2561-0	CAP,CER AXIAL,561,10%,50V,X7R	2	C1,C4
2	038-0106-0	CAP,ELEC,AXIAL TR,106,20%,16V	2	C2,C3
2	038-3477-0	CAP,ELEC AXIAL,477,-10%+50%,63V	4	C5,C6,C7,C8
2	038-4108-0	CAP,ELEC AXIAL,108,-10%+50%,100V	6	C9,C10,C11,C12,C13,C14
2	051-0101-0	RES,CARBON FILM,10 OHM,1/4W,5%	2	R3,R4
2	051-5603-0	RES,CARBON FILM,56K OHM,1/4W,5%	2	R1,R2
2	093-0032-0	0000 HSG,.156X3,22GA,LOCK	1	P1
2	145-0048-C	0000 800RB SUPPLY BRD	1	

206-0045-E 800RB Preamp Board

LVL	PART#	DESCRIPTION	QTY	REF. DESIG.
2	001-1030-0	LF353N DUAL JFET OP AMP	6	U1,U2,U3,U4,U6,U7
2	001-3029-0	DG419DJ, DUAL COMP ANALOG SWITCH	1	U5
2	010-2010-0	J113 N-JFET 35V 2MA TO-92	1	Q89
2	020-0120-0	1N759A,ZENER,12V,5%,400MW,DO-35	4	D8,D9,D72,D74
2	030-2101-0	CAP,CER,AX,101,10%,50V,NPO	2	C6,C31
2	030-2103-0	CAP,CER,AX,103,10%,50V,X7R	3	C26,46,54
2	030-2104-0	CAP,CER,AX,104,10%,50V,X7R	2	C42,C62
2	030-2222-0	CAP,CER,AX,222,10%,50V,X7R	3	C37,C40,C56
2	030-2224-0	CAP,CER AXIAL,224,20%,50V,Z5U	5	C23,C25,C85,C86,C95
2	030-2470-0	CAP,CER AXIAL,47 PF,10%,50V,NPO	1	C49
2	030-2472-0	CAP,CER AXIAL,472,10%,50V,X7R	5	C14,C15,C104,C113, ECO 27
2	030-2561-0	CAP,CER AXIAL,561,10%,50V,X7R	2	C7,C20
2	031-1227-0	CAP,ELEC,RAD,227,-10%+50%,25V	2	C66,C67
2	031-2335-0	CAP,ELEC,RAD,335,20%,50V	5	C21,61,70,99,112
2	032-3104-0	CAP,PE,104,5%,63V	1	C2

2	038-0106-0	CAP,ELEC,AXIAL TR,106,20%,16V	4	C11,C75,C92,C93
2	051-1001-0	RES,CARBON FILM,100 OHM,1/4W,5%	1	R94
2	051-1002-0	RES,CARBON FILM,1K OHM,1/4W,5%	5	R69,R71,R76,R86A,R90
2	051-1004-0	RES,CARBON FILM,100K OHM,1/4W,5%	2	R107,R116
2	051-1005-0	RES,CARBON FILM,1M OHM,1/4W,5%	1	R4
2	051-1203-0	RES,CARBON FILM,12K OHM,1/4W,5%	9	R1,R12,R35,R39,R43,R47,R77,R83,R88
2	051-1204-0	RES,CARBON FILM,120K OHM,1/4W,5%	1	R13
2	051-2201-0	RES,CARBON FILM,220 OHM,1/4W,5%	2	R63,R81
2	051-2202-0	RES,CARBON FILM,2.2K OHM,1/4W,5%	2	R87A,R117
2	051-2203-0	RES,CARBON FILM,22K OHM,1/4W,5%	6	R32,R60,R97,R101,R106,R108
2	051-2204-0	RES,CARBON FILM,220K OHM,1/4W,5%	2	R19,R22
2	051-3302-0	RES,CARBON FILM,3.3K OHM,1/4W,5%	1	R24
2	051-3303-0	RES,CARBON FILM,33K OHM,1/4W,5%	4	R5,16,103,111
2	051-4701-0	RES,CARBON FILM,470 OHM,1/4W,5%	1	R73
2	051-4702-0	RES,CARBON FILM,4.7K OHM,1/4W,5%	5	R3,R30,R91,R96,R98
2	051-4703-0	RES,CARBON FILM,47K OHM,1/4W,5%	4	R41,48,57,84
2	051-4704-0	RES,CARBON FILM,470K OHM,1/4W,5%	5	R29,R33,R39,R44,R50
2	051-5602-0	RES,CARBON FILM,5.6K OHM,1/4W,5%	5	R28,R45,R51,R58,R59
2	052-0000-0	RES,CARBON FILM 0 OHM,1/4W,5%	18	R110,114,105,109,102,79,80,81,82,87,65,52,34,18, R55,17A,115A,10,12
2	070-1513-0	POT,50K-15A,7MM,KNURL, .1W	1	R17- volume
2	070-1514-0	POT,50KB,7MM,KNURL, .1W	6	R36,53,64,68,115,118- EQ, master pots
2	070-1522-0	POT,2KB,7MM,KNURL, .1W	1	R82- boost
2	070-1523-0	POT,2X50KB,7MM,KNURL, .1W	1	R100- x-over frequency
2	090-0014-0	SWITCH,PP,DPDT, .2A,BREAK/MAKE,PC	5	S1,S2,S3,S4,S5- all switches
2	092-0076-0	JACK S2-BNB, 1/4", S-TIP, PC TERM	2	J1,J2- all jacks
2	093-0028-0	HDR, .156X3, VERT, MALE, LOCK	1	P1
2	093-0033-0	HDR, .156X5, VERT, MALE, LOCK, ROUND	1	P2
2	093-0082-0	HDR, .156X2, VERT, MALE, LOCK	1	P3
2	145-0045-E	800RB PREAMP BRD	1	

